

Silicon NPN Power Transistors

2SC4157

DESCRIPTION

- With TO-3P(I) package
- High  $V_{CE0}$
- High speed switching

APPLICATIONS

- Switching regulator and high voltage switching applications
- High speed DC-DC converter applications

PINNING

PIN	DESCRIPTION
1	Base
2	Collector;connected to mounting base
3	Emitter

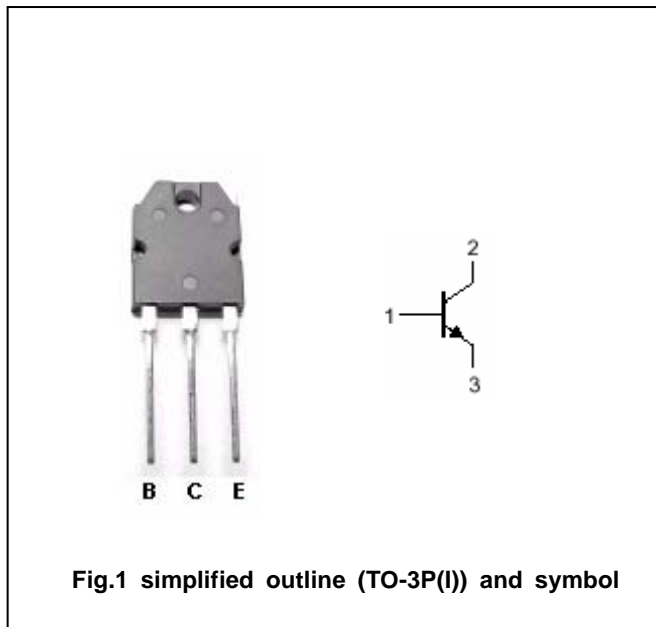

Absolute maximum ratings( $T_a=25^\circ C$ )

SYMBOL	PARAMETER	CONDITIONS	VALUE	UNIT
$V_{CBO}$	Collector-base voltage	Open emitter	600	V
$V_{CEO}$	Collector-emitter voltage	Open base	450	V
$V_{EBO}$	Emitter-base voltage	Open collector	8	V
$I_C$	Collector current-DC		10	A
$I_{CM}$	Collector current-peak		20	A
$I_B$	Base current		5	A
$P_T$	Total power dissipation	$T_C=25$	100	W
$T_j$	Junction temperature		150	
$T_{stg}$	Storage temperature		-55~150	

## Silicon NPN Power Transistors

## 2SC4157

## CHARACTERISTICS

T<sub>j</sub>=25 unless otherwise specified

SYMBOL	PARAMETER	CONDITIONS	MIN	TYP.	MAX	UNIT
V <sub>(BR)CEO</sub>	Collector-emitter breakdown voltage	I <sub>C</sub> =10mA, I <sub>B</sub> =0	450			V
V <sub>(BR)CBO</sub>	Collector-base breakdown voltage	I <sub>C</sub> =1mA, I <sub>E</sub> =0	600			V
V <sub>CEsat</sub>	Collector-emitter saturation voltage	I <sub>C</sub> =5A; I <sub>B</sub> =1A			1.0	V
V <sub>BEsat</sub>	Base-emitter saturation voltage	I <sub>C</sub> =5A; I <sub>B</sub> =1A			2.0	V
I <sub>CBO</sub>	Collector cut-off current	V <sub>CB</sub> =500V; I <sub>E</sub> =0			100	μA
I <sub>EBO</sub>	Emitter cut-off current	V <sub>EB</sub> =8V; I <sub>C</sub> =0			1.0	mA
h <sub>FE</sub>	DC current gain	I <sub>C</sub> =5A; V <sub>CE</sub> =5V	15			

## Switching times

t <sub>r</sub>	Rise time	V <sub>CC</sub> 200V I <sub>B1</sub> =-I <sub>B2</sub> =0.5A; R <sub>L</sub> =40			0.5	μs
t <sub>stg</sub>	Storage time				2.5	μs
t <sub>f</sub>	Fall time				0.5	μs

Silicon NPN Power Transistors

2SC4157

PACKAGE OUTLINE

