

Silicon PNP Power Transistors

TIP34/34A/34B/34C

DESCRIPTION

- With TO-3PN package
- Complement to type TIP33/33A/33B/33C
- DC current gain $h_{FE}=40(\text{Min})@I_C=1.0\text{A}$

APPLICATIONS

- Designed for use in general purpose power amplifier and switching applications.

PINNING

PIN	DESCRIPTION
1	Base
2	Collector;connected to mounting base
3	Emitter

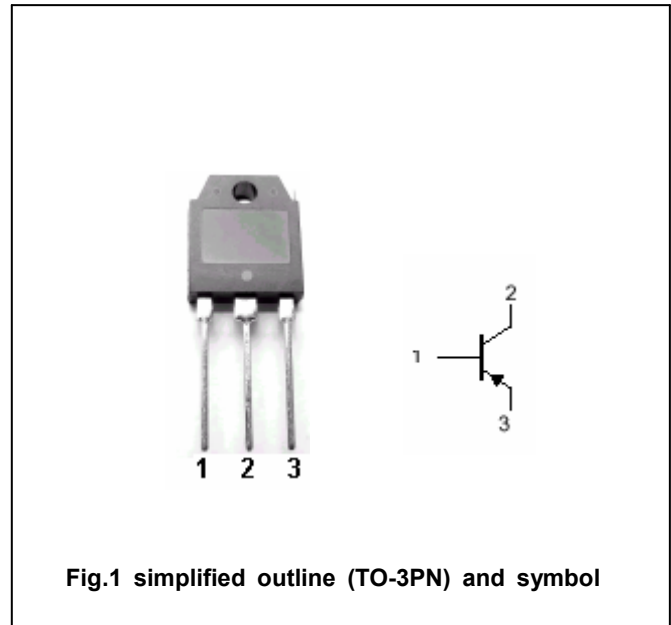

Fig.1 simplified outline (TO-3PN) and symbol

ABSOLUTE MAXIMUM RATINGS($T_C=25^\circ\text{C}$)

SYMBOL	PARAMETER	CONDITIONS	VALUE	UNIT
V_{CBO}	Collector-base voltage	TIP34	-40	V
		TIP34A	-60	
		TIP34B	-80	
		TIP34C	-100	
V_{CEO}	Collector-emitter voltage	TIP34	-40	V
		TIP34A	-60	
		TIP34B	-80	
		TIP34C	-100	
V_{EBO}	Emitter-base voltage	Open collector	-5	V
I_C	Collector current		-10	A
I_{CM}	Collector current-peak		-15	A
I_B	Base current		-3	A
P_C	Collector power dissipation	$T_C=25^\circ\text{C}$	80	W
T_j	Junction temperature		150	$^\circ\text{C}$
T_{stg}	Storage temperature		-65~150	$^\circ\text{C}$

THERMAL CHARACTERISTICS

SYMBOL	PARAMETER	MAX	UNIT
$R_{th\ j-c}$	Thermal resistance junction to case	1.56	$^\circ\text{C}/\text{W}$

Silicon PNP Power Transistors

TIP34/34A/34B/34C

CHARACTERISTICS

T_j=25 °C unless otherwise specified

SYMBOL	PARAMETER		CONDITIONS	MIN	TYP.	MAX	UNIT
V _{CEO(SUS)}	Collector-emitter sustaining voltage	TIP34	I _C =-30mA ; I _B =0	-40			V
		TIP34A		-60			
		TIP34B		-80			
		TIP34C		-100			
V _{CE(sat)-1}	Collector-emitter saturation voltage		I _C =-3A ; I _B =-0.3A			-1.0	V
V _{CE(sat)-2}	Collector-emitter saturation voltage		I _C =-10A ; I _B =-2.5A			-4.0	V
V _{BE-1}	Base-emitter on voltage		I _C =-3A ; V _{CE} =-4V			-1.6	V
V _{BE-2}	Base-emitter on voltage		I _C =-10A ; V _{CE} =-4V			-3.0	V
I _{CEO}	Collector cut-off current	TIP34/34A	V _{CE} =-30V ; I _B =0			-0.7	mA
		TIP34B/34C	V _{CE} =-60V ; I _B =0				
I _{CES}	Collector cut-off current	TIP34	V _{CE} =-40V ; V _{EB} =0			-0.4	mA
		TIP34A	V _{CE} =-60V ; V _{EB} =0				
		TIP34B	V _{CE} =-80V ; V _{EB} =0				
		TIP34C	V _{CE} =-100V ; V _{EB} =0				
I _{EBO}	Emitter cut-off current		V _{EB} =-5V ; I _C =0			-1.0	mA
h _{FE-1}	DC current gain		I _C =-1A ; V _{CE} =-4V	40			
h _{FE-2}	DC current gain		I _C =-3A ; V _{CE} =-4V	20		100	
f _T	Transition frequency		I _C =-0.5A ; V _{CE} =-10V ; f=1MHz	3.0			MHz

Silicon PNP Power Transistors

TIP34/34A/34B/34C

PACKAGE OUTLINE

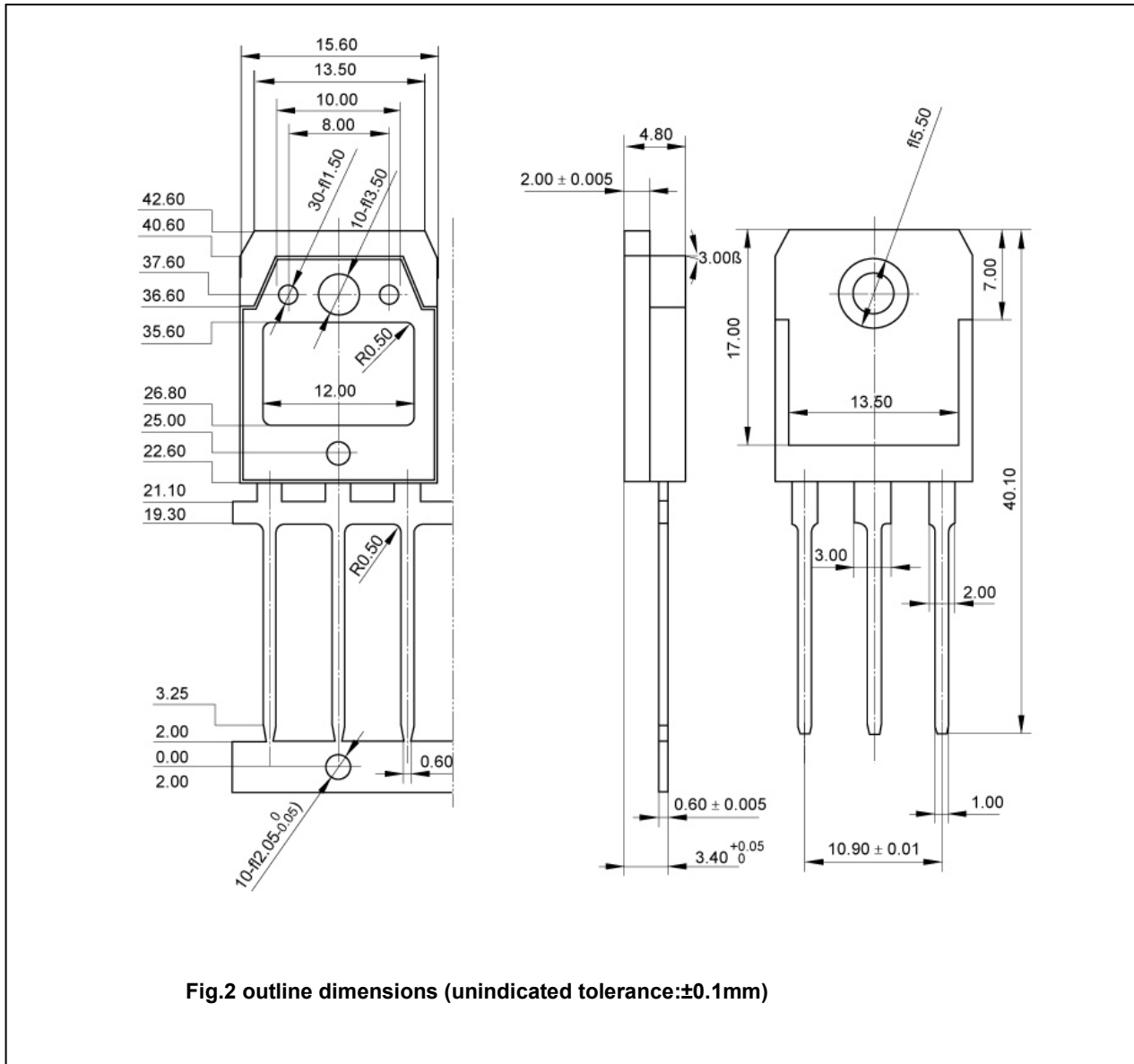

Fig.2 outline dimensions (unindicated tolerance:±0.1mm)