



actual size

Oscillator · JO21 · 3.3 V

SMD Oscillator with Stop Function · 2.0 x 1.6 mm

- ultra small package
- low current consumption
- reflow soldering temperature: 260 °C max.
- ultra flat ceramic / metal package



General Data

type	JO21 3.3 V	
frequency range	0.85 ~ 50.0 MHz	
frequency stability over all*	± 50 ppm ~ ± 100 ppm	
	see table 1	
current consumption	see table 2	
supply voltage V _{DC}	3.3 V ± 5%	
temperature	operating	-20 °C ~ +70 °C / -40 °C ~ +85 °C
	storage	-55 °C ~ +100 °C
output	rise & fall time	see table 3
	load max.	15 pF
	current max.	4 mA
	low level max.	0.1 x V _{DC}
	high level min.	0.9 x V _{DC}
output enable time max.	10 ms	
output disable time max.	50 µs	
start-up time max.	10 ms	
standby function	stop	
standby current max.	5 µA	
symmetry at 0.5 x V _{DC}	45% ~ 55% max.	

Table 1: Frequency Stability Code

stability code	A	B				
	± 100 ppm	± 50 ppm				
-20 °C ~ +70 °C		○				
-40 °C ~ +85 °C	○	○				

● standard ○ available

* includes stability at 25 °C, operating temp. range, supply voltage change, shock and vibration, aging 1st year.

Table 2: Current Consumption max.

3.3 V: current at 15pF load:	
0.85 ~ 19.9 MHz	6 mA
20.00 ~ 39.9 MHz	7 mA
40.00 ~ 50.0 MHz	8 mA

Table 3: Rise & Fall Time max.

5 ns: 0.85 ~ 50.0 MHz	note: - specific data on request - rise time: 0.1 V _{DC} ~ 0.9 V _{DC} - fall time: 0.9 V _{DC} ~ 0.1 V _{DC}
-----------------------	--

Dimensions

pin connection
 # 1: e/d
 # 2: ground
 # 3: output
 # 4: V_{DC}

in mm

Order Information

0	frequency	type	frequency stability code	supply voltage code	output load code	option
Oscillator	0.85 ~ 50.0 MHz	JO21	see table 1	3.3 = 3.3 V	1 = 15 pF	blank = -20 °C ~ +70 °C T1 = -40 °C ~ +85 °C

Example: O 20.0-JO21-B-3.3-1 (LF = RoHS compliant / Pb free pins or pads)



Oscillator · JO21 · 3.3 V · Stop Function

Taping Specification

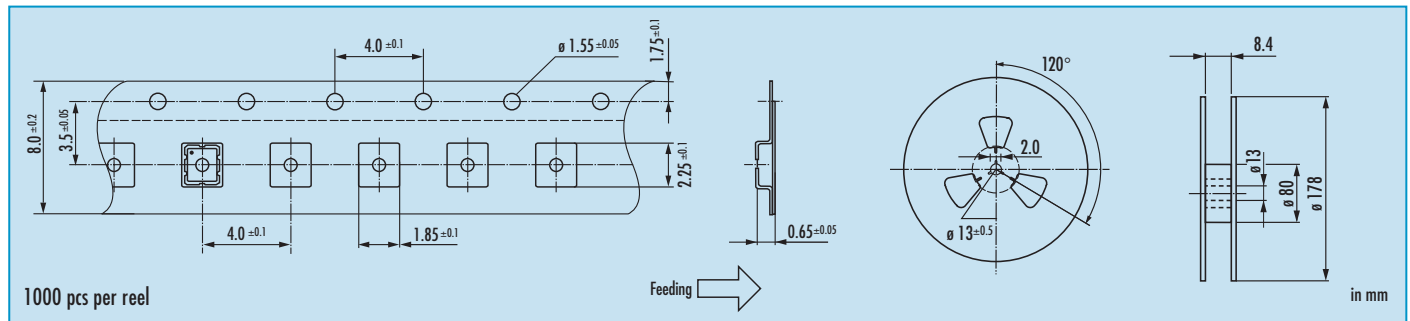

Enable / Disable Function

pin #1 (e/d control)	pin #3 (output)
open	active
high "1" ($V_{IH} \geq 0.8 V_{DC}$)	active
low "0" ($V_{IL} \leq 0.2 V_{DC}$)	high impedance

stop function:

- oscillator stops
- output high impedance

Marking

frequency
J / stability code / date code

date code:
A ~ M: Jan.- Dec.
9: 2009
0: 2010
1: 2011

Jan.	Febr.	Mar.	Apr.	May	June
A	B	C	D	E	F
July	Aug.	Sept.	Oct.	Nov.	Dec.
G	H	J	K	L	M

Reflow Soldering Profile

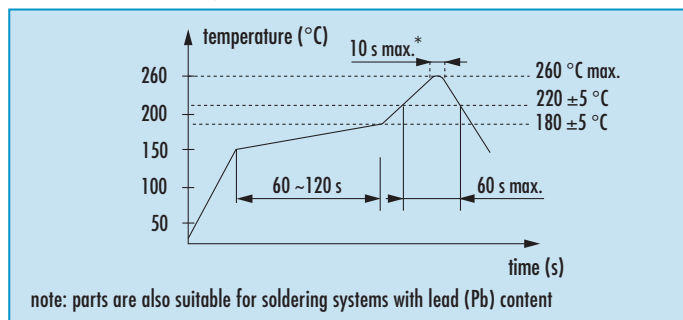

Packing Note

- standard packing units are 1000 pieces per reel
- non-multiple packing units are only supplied taped / bulk

* hand soldering temperature should not exceed 280 °C