

185-960 (06 Plug) Expanded Beam Fiber Optic Connector 960 Series: Eurocomm Type II Hermaphroditic



185-960-A 06-C-50/125

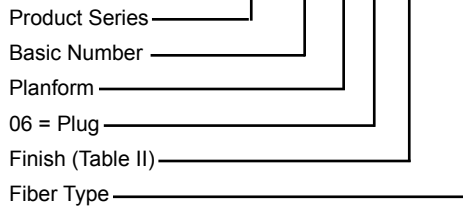
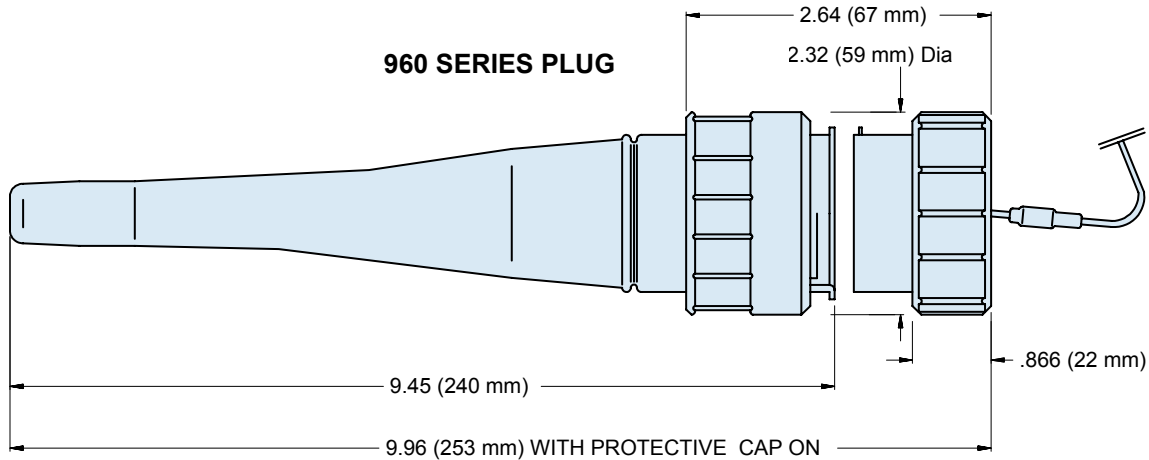

TABLE II: FINISH		
SYM	Material	FINISH
C	Aluminum	Anodized, Black
AB	Aluminum	Nickel Aluminum Bronze



PLANFORMS

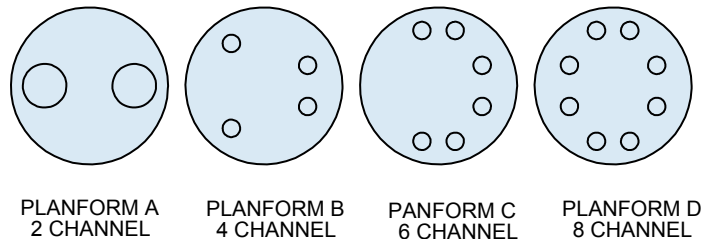

TABLE I: PERFORMANCE	
Optical Loss	50/125 @ 850/1300nm 1.0 dB Typical
Operating Temperature	-40°C to +70°C
Storage Temperature	-55°C to +85°C
Water Immersion	Up to 2M Depth
Vibration Sinusoidal	10-500Hz, 0.75 Amplitude @ 10g Acceleration
Free Fall Resistance	500 Falls onto Concrete from 1.2M height
Bump Resistance	4,000 Bumps @ 40g Acceleration
Tensile Strength	Tensile of 1,800N, Cable Dependent
Cable Variations	Compatible with Tactical cable: Plug <6.5mm O/D Bulkhead Other Cable Sizes Available on request

**PART SUPPLIED ONLY AS
TERMINATED ASSEMBLY**

**CONSULT FACTORY
FOR CABLE DESIGN**

All Tests Compliant to BS EN 186000-1 Specifications