

Silicon NPN Power Transistors

2SC3235

DESCRIPTION

- With TO-220 package
- High voltage,high speed
- Low saturation voltage

APPLICATIONS

- For high voltage ,high speed and high power switching applications

PINNING

| PIN | DESCRIPTION |
|-----|--------------------------------------|
| 1 | Base |
| 2 | Collector;connected to mounting base |
| 3 | Emitter |

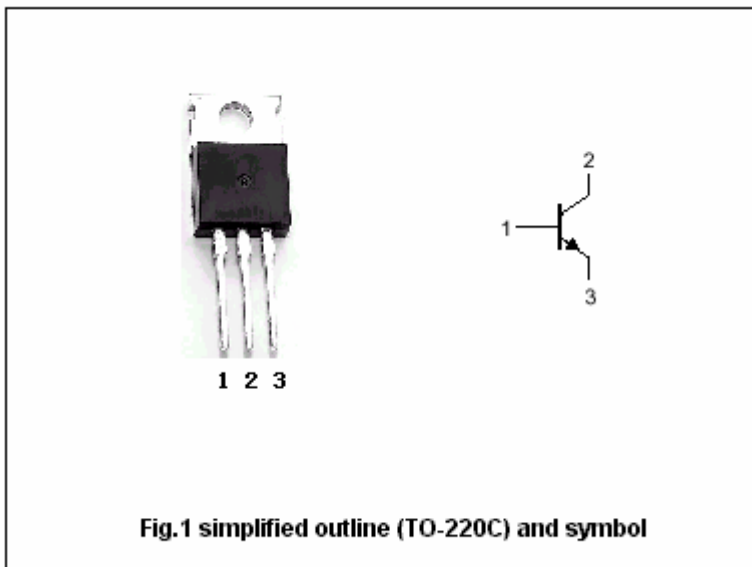

Absolute maximum ratings(Ta=25°C)

| SYMBOL | PARAMETER | CONDITIONS | VALUE | UNIT |
|------------------|-----------------------------|----------------------|---------|------|
| V _{CBO} | Collector-base voltage | Open emitter | 500 | V |
| V _{CEO} | Collector-emitter voltage | Open base | 400 | V |
| V _{EBO} | Emitter-base voltage | Open collector | 7 | V |
| I _C | Collector current | | 2 | A |
| I _{CM} | Collector current-Peak | | 4 | A |
| P _C | Collector power dissipation | T _C =25°C | 20 | W |
| T _j | Junction temperature | | 150 | °C |
| T _{stg} | Storage temperature | | -55~150 | °C |

Silicon NPN Power Transistors

2SC3235

CHARACTERISTICS

T_j=25 °C unless otherwise specified

| SYMBOL | PARAMETER | CONDITIONS | MIN | TYP. | MAX | UNIT |
|----------------------|--------------------------------------|--|-----|------|-----|------|
| V _{(BR)CEO} | Collector-emitter breakdown voltage | I _C =10mA; I _B =0 | 400 | | | V |
| V _{(BR)CBO} | Collector-base breakdown voltage | I _C =1mA; I _E =0 | 500 | | | V |
| V _{(BR)EBO} | Emitter-base breakdown voltage | I _E =1mA; I _C =0 | 7 | | | V |
| V _{CEsat} | Collector-emitter saturation voltage | I _C =1A; I _B =0.2 A | | | 1.0 | V |
| V _{BEsat} | Base-emitter saturation voltage | I _C =1A; I _B =0.2 A | | | 1.5 | V |
| I _{CBO} | Collector cut-off current | V _{CB} =400V; I _E =0 | | | 10 | μA |
| I _{EBO} | Emitter cut-off current | V _{EB} =5V; I _C =0 | | | 10 | μA |
| h _{FE} | DC current gain | I _C =0.1A ; V _{CE} =5V | 20 | | 50 | |

Silicon NPN Power Transistors

2SC3235

PACKAGE OUTLINE

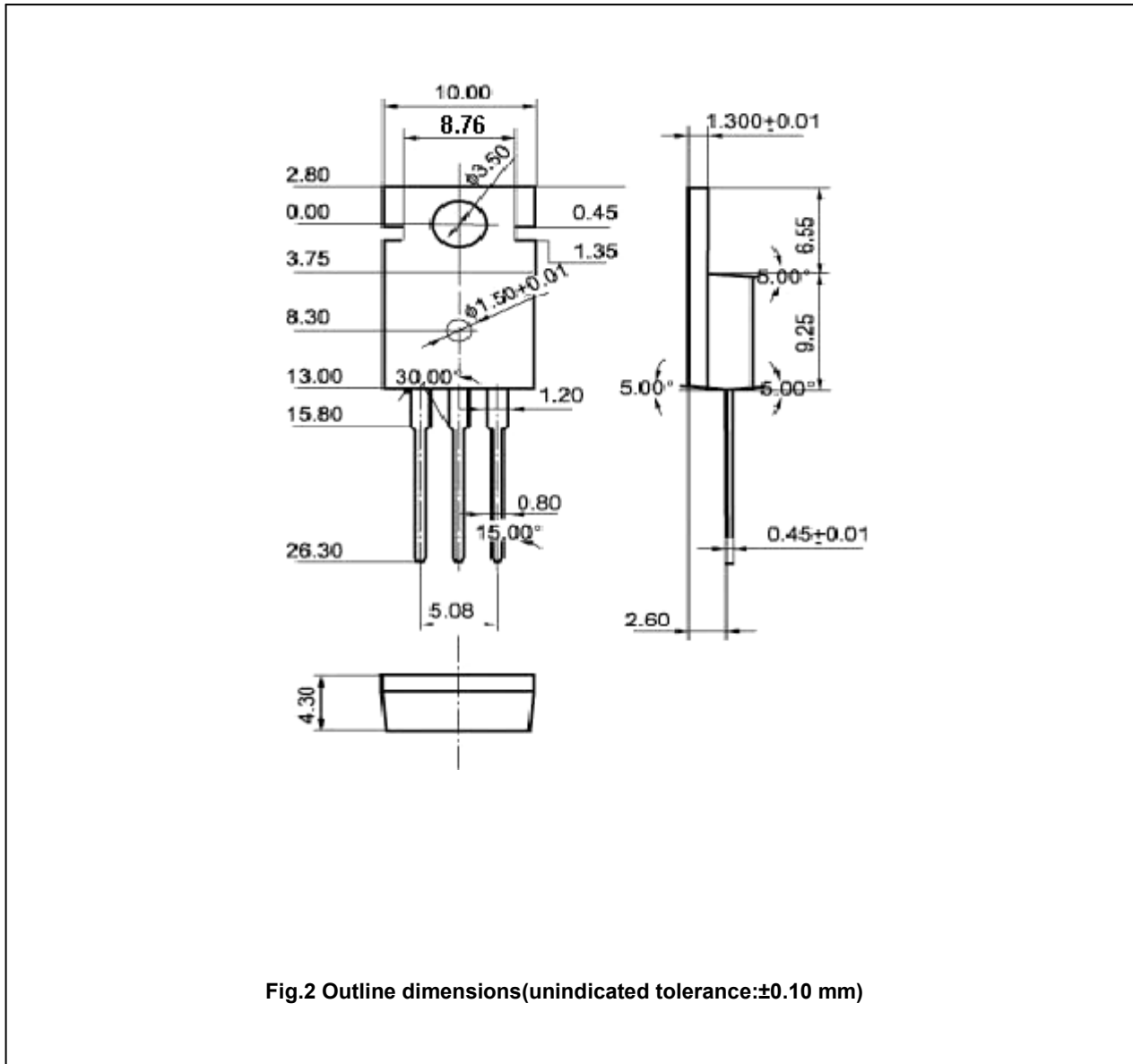

Fig.2 Outline dimensions(unindicated tolerance:±0.10 mm)