



# TAI-SAW TECHNOLOGY CO., LTD.

No. 3, Industrial 2nd Rd., Ping-Chen Industrial District,  
Taoyuan, 324, Taiwan, R.O.C.

TEL: 886-3-4690038 FAX: 886-3-4697532

E-mail: [tstsales@mail.taisaw.com](mailto:tstsales@mail.taisaw.com) Web: [www.taisaw.com](http://www.taisaw.com)

## Approval Sheet For Product Specification

Issued Date: August, 2, 2004

Product Name: SAW Filter 1960 MHz for Mobile Communication

TST Parts No.: TA0246A

Customer Parts No.: \_\_\_\_\_

Company: \_\_\_\_\_

Division: \_\_\_\_\_

Approved by : \_\_\_\_\_

Date: \_\_\_\_\_

Checked by: \_\_\_\_\_ Bob Chau

Approval by: \_\_\_\_\_ Francis Chen

Date: \_\_\_\_\_ August, 2, 2004



# TAI-SAW TECHNOLOGY CO., LTD.

No. 3, Industrial 2nd Rd., Ping-Chen Industrial District,  
Taoyuan, 324, Taiwan, R.O.C.

TEL: 886-3-4690038 FAX: 886-3-4697532

E-mail: [tstsales@mail.taisaw.com](mailto:tstsales@mail.taisaw.com) Web: [www.taisaw.com](http://www.taisaw.com)

## SAW Filter 1960 MHz for Mobile Communication

MODEL NO.: TA0246A

REV. NO.:3

### A. MAXIMUM RATING:

1. Operating Temperature: -20°C ~ +75°C
2. Storage Temperature: -40°C ~ +85°C

RoHS Compliant  
Lead free  
Lead-free soldering

### B. ELECTRICAL CHARACTERISTICS :

Singled to Balanced operation

Terminating source impedance :  $Z_s = 50 \Omega$

Terminating load impedance :  $Z_L = 200 \Omega // 18 \text{ nH}$

Item			Value			Note
			Min.	Typ.	Max.	
<b>Center frequency</b>	$F_c$	MHz	-	1960	-	-
<b>Insertion loss</b> ( 1930~1990 MHz)	<b>I.L.</b>	(dB)	-	2.7	4.0	-
<b>Ripple</b>	( 1930~1990 MHz)	(dB)	-	0.6	2.4	-
<b>Input VSWR</b>	( 1930~1990 MHz)		-	1.8	2.4	-
<b>Output VSWR</b>	( 1930~1990 MHz)		-	2.0	2.4	-
<b>Attenuation:</b> ( Reference level from 0 dB)						
0 ~ 1000	MHz	(dB)	45	55	-	-
1000 ~ 1830	MHz	(dB)	25	31	-	-
1830 ~ 1900	MHz	(dB)	15	25	-	-
1900 ~ 1910	MHz	(dB)	7	12.5	-	-
2010 ~ 2030	MHz	(dB)	5	8	-	-
2030 ~ 2070	MHz	(dB)	12	18	-	-
2070 ~ 2310	MHz	(dB)	20	23.5	-	-
2310 ~ 2380	MHz	(dB)	35	38	-	-
2380 ~ 4600	MHz	(dB)	30	39	-	-
4600 ~ 6000	MHz	(dB)	23	54	-	-
<b>Symmetry in band</b> (referenced to the matched operating condition)						
$ S_{31} / S_{21} $	( 1930~1990 MHz)	(dB)	-2.0	0	1.5	-
$\Phi(S_{31})-\Phi(S_{21})$	( 1930~1990 MHz)	degree	-15	0	15	-

### C. OUTLINE DRAWING:

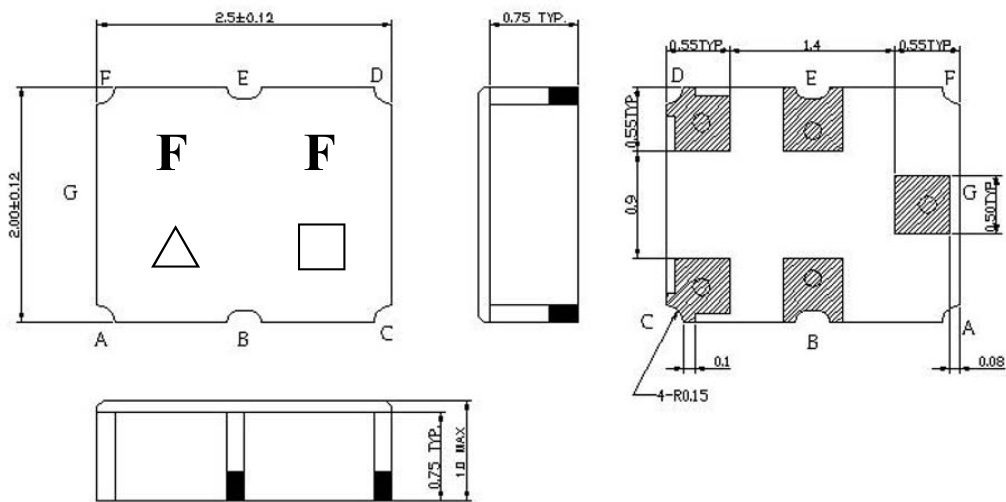

### Pin configuration

- G : Unbalance input
- C,D : Balance output
- B,E : Ground
- △ : Year code (2004->4, 2005->5, ..., 2009->9)
- : Date code
- Unit : mm

**D. PCB Footprint:**

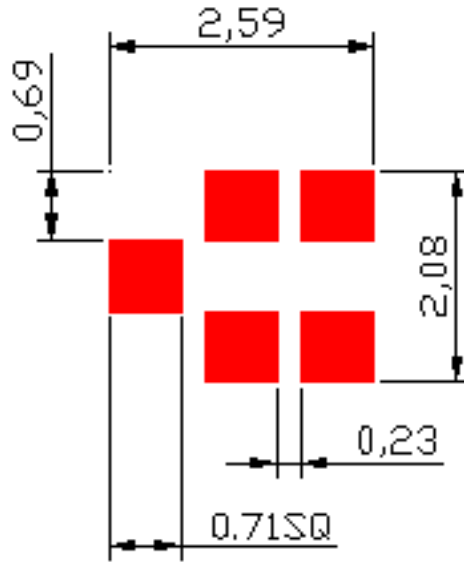

**E. MEASUREMENT CIRCUIT:**

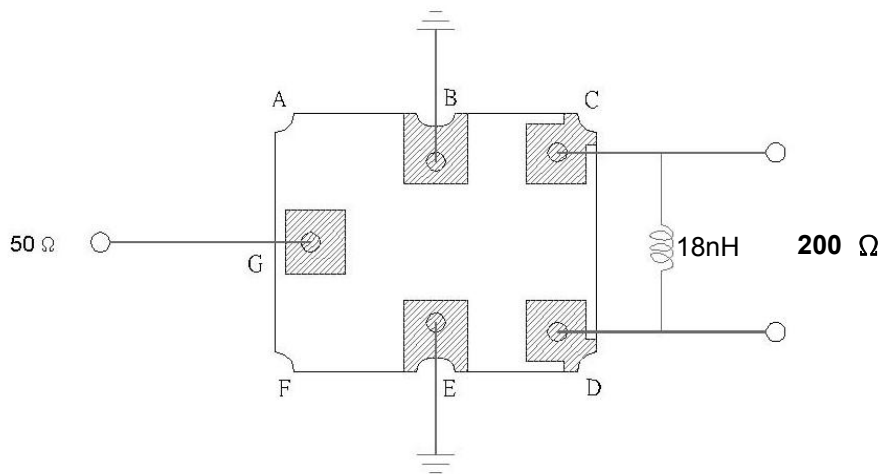

## F. FREQUENCY CHARACTERISTICS:

### 1. Transfer function (25 °C)

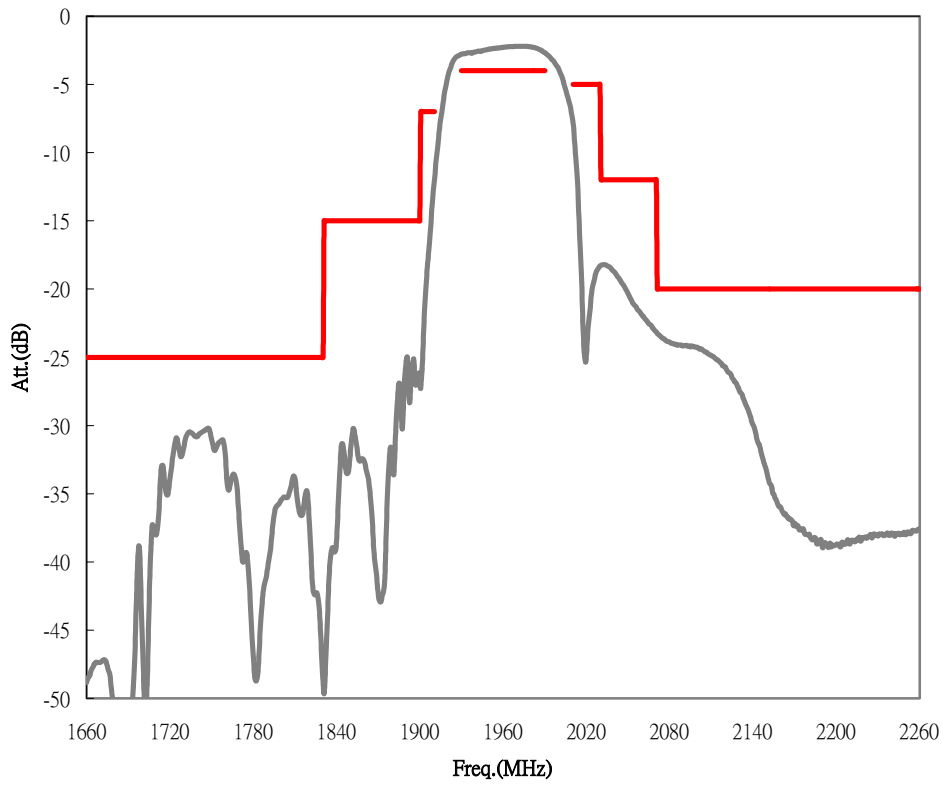

(wideband)

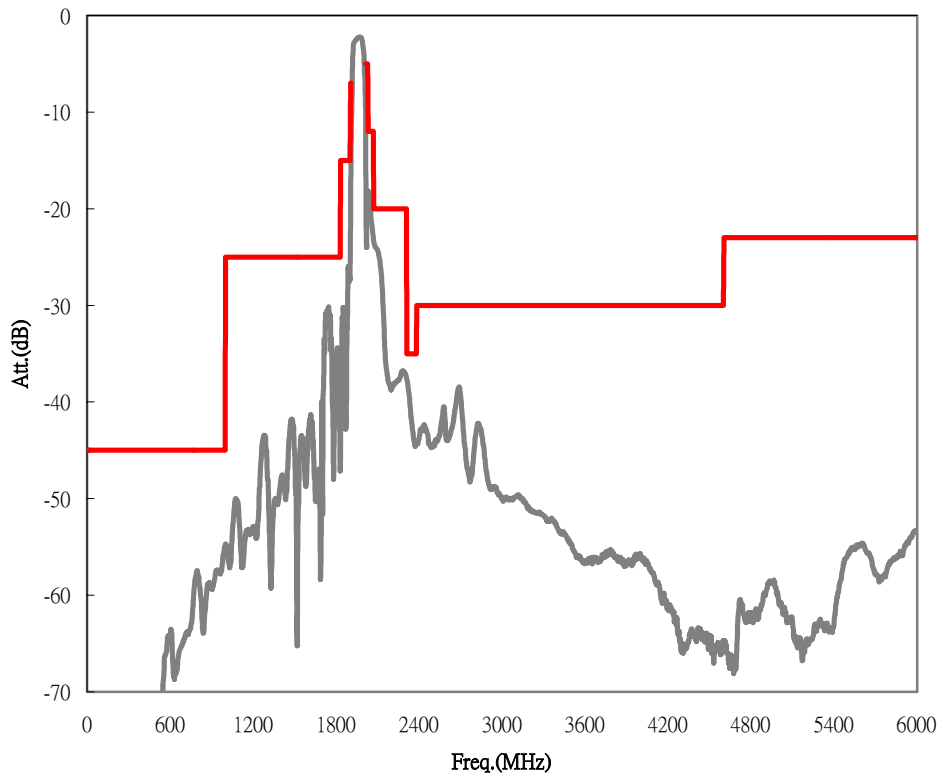

## 2. VSWR (25 °C)

### Unbalance Input

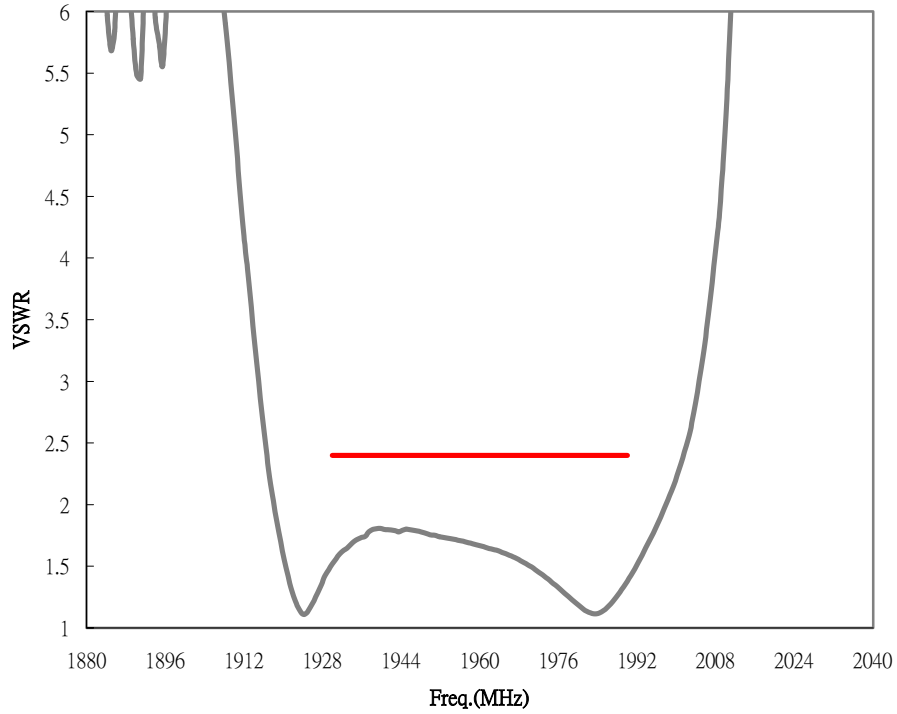

### Balance Output

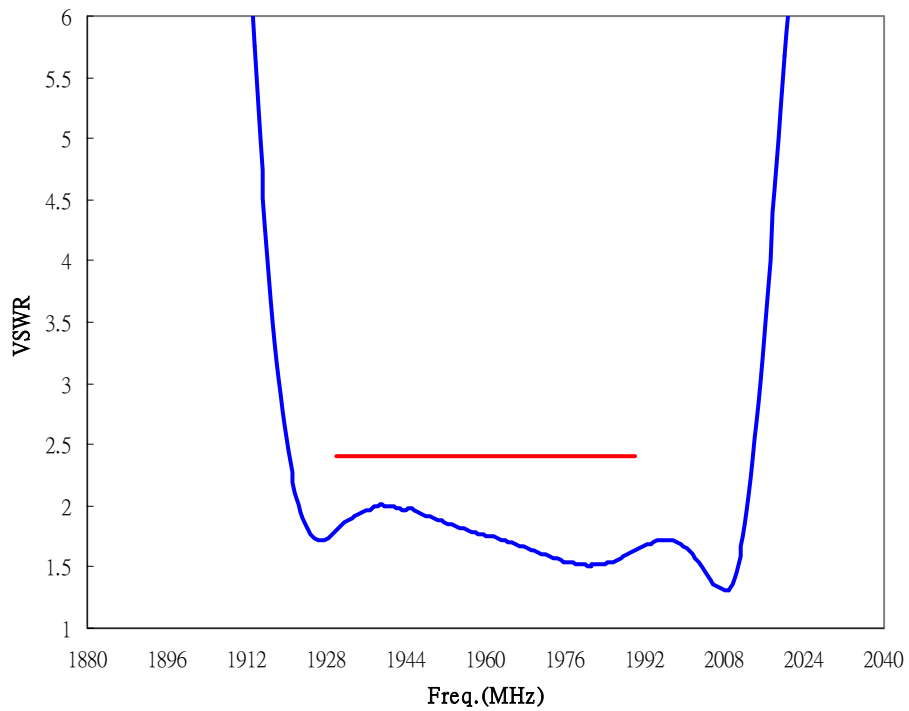

**G. PACKING:**

**1. REEL DIMENSION**

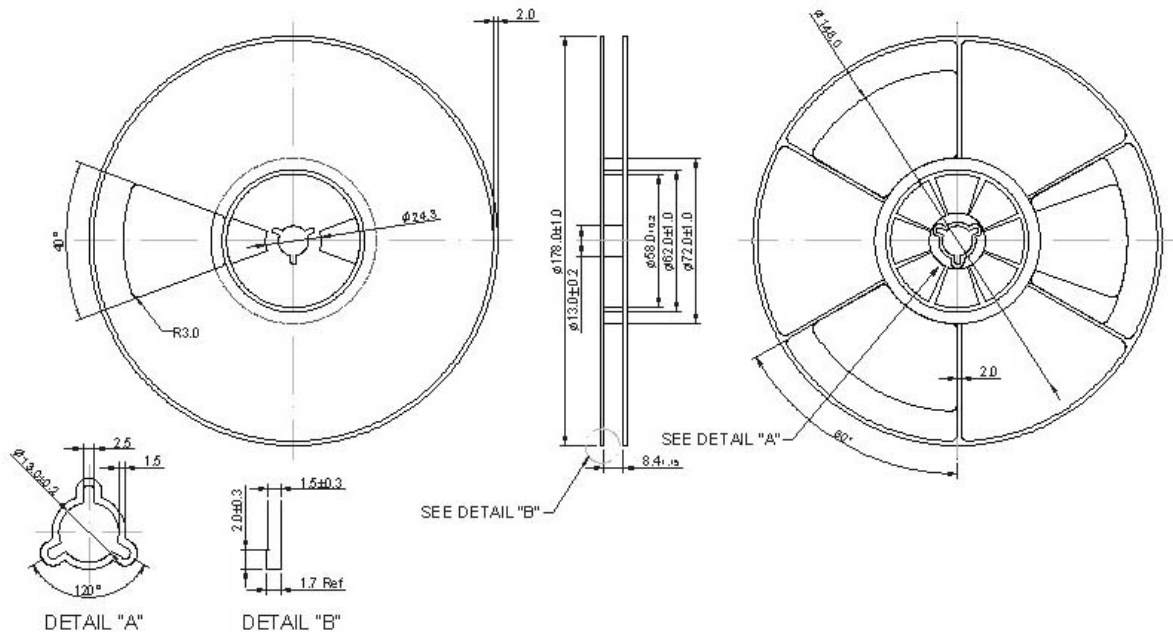

**2. TAPE DIMENSION**

