

RF MOSFET Power Transistor, 10W, 28V

2 - 175 MHz

DU2810S

V2.00

Features

- N-Channel Enhancement Mode Device
- DMOS Structure
- Lower Capacitances for Broadband Operation
- Common Source Configuration
- Low Noise Floor

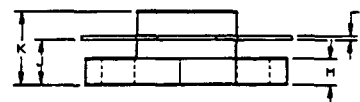
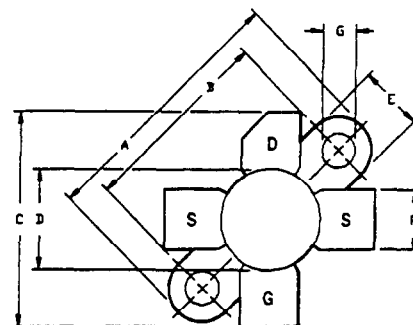

Absolute Maximum Ratings at 25°C

Parameter	Symbol	Rating	Units
Drain-Source Voltage	V_{DS}	65	V
Gate-Source Voltage	V_{GS}	20	V
Drain-Source Current	I_{DS}	2.8	A
Power Dissipation	P_D	35	W
Junction Temperature	T_J	200	°C
Storage Temperature	T_{STG}	-65 to +150	°C
Thermal Resistance	θ_{JC}	2	°C/W

LETTER DIM	MILLIMETERS		INCHES	
	MIN	MAX	MIN	MAX
A	24.64	24.89	.970	.980
B	18.29	18.54	.720	.730
C	20.07	20.83	.790	.820
D	9.47	9.73	.373	.383
E	6.22	6.48	.245	.255
F	5.64	5.79	.222	.228
G	2.92	3.30	.115	.130
H	2.29	2.67	.090	.105
J	4.04	4.55	.159	.179
K	6.58	7.39	.259	.291
L	.10	.15	.004	.006

Electrical Characteristics at 25°C

Parameter	Symbol	Min	Max	Units	Test Conditions
Drain-Source Breakdown Voltage	BV_{DSS}	65	-	V	$V_{GS}=0.0\text{ V}, I_{DS}=4.0\text{ mA}$
Drain-Source Leakage Current	I_{DSS}	-	2.0	mA	$V_{DS}=28.0\text{ V}, V_{GS}=0.0\text{ V}$
Gate-Source Leakage Current	I_{GSS}	-	2.0	μA	$V_{GS}=20.0\text{ V}, V_{DS}=0.0\text{ V}$
Gate Threshold Voltage	$V_{GS(TH)}$	2.0	6.0	V	$V_{DS}=10.0\text{ V}, I_{DS}=20\text{ mA}$
Forward Transconductance	G_M	160	-	mS	$V_{DS}=10.0\text{ V}, I_{DS}=200\text{ mA}, \text{ Pulsed } 80\text{-}300\text{ }\mu\text{s}$
Input Capacitance	C_{ISS}	-	14	pF	$V_{DS}=28.0\text{ V}, F=1.0\text{ MHz}$
Output Capacitance	C_{OSS}	-	10	pF	$V_{DS}=28.0\text{ V}, F=1.0\text{ MHz}$
Reverse Capacitance	C_{RSS}	-	4.6	pF	$V_{DS}=28.0\text{ V}, F=1.0\text{ MHz}$
Power Gain	G_p	13	-	dB	$V_{DD}=28.0\text{ V}, I_{DQ}=100\text{ mA}, P_{OUT}=10\text{ W}, F=175\text{ MHz}$
Drain Efficiency	η_D	55	-	%	$V_{DD}=28.0\text{ V}, I_{DQ}=100\text{ mA}, P_{OUT}=10\text{ W}, F=175\text{ MHz}$
Load Mismatch Tolerance	VSWR-T	-	20:1	-	$V_{DD}=28.0\text{ V}, I_{DQ}=100\text{ mA}, P_{OUT}=10\text{ W}, F=175\text{ MHz}$

Typical Device Impedance

Frequency (MHz)	Z_{IN} (OHMS)	Z_{LOAD} (OHMS)
30	27.0 - j 11.0	23.0 - j 3.0
50	24.0 - j 15.0	19.0 - j 5.0
100	18.0 - j 18.0	14.0 - j 6.0
200	12.0 - j 19.0	9.0 - j 5.0

$$V_{DD}=28 \text{ V, } I_{DQ}=100 \text{ mA, } P_{OUT}=10.0 \text{ Watts}$$

Z_{IN} is the series equivalent input impedance of the device from gate to source.

Z_{LOAD} is the series equivalent load impedance as measured from drain to ground.

RF Test Fixture

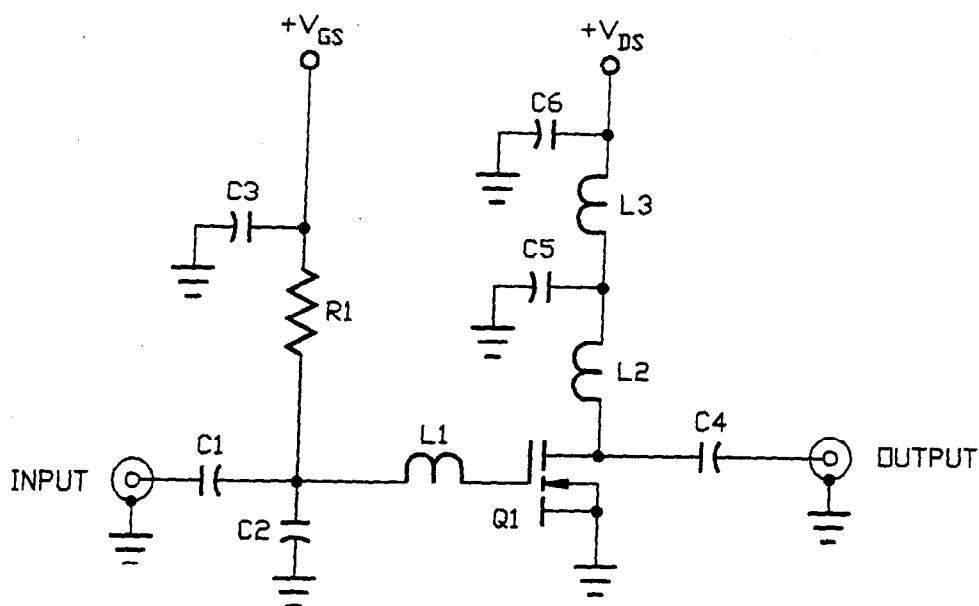

C2	20 pF, UNELCO
C1 C3	500 pF, UNELCO
C4 C5	1000 pF, UNELCO
C6	5 μ F ELECTROLYTIC
R1	12K OHM
L2	4 TURNS OF NO. 16 AWG ON .10" ID
L1	2 TURNS OF NO. 16 AWG ON .35" ID
L3	5 TURNS OF NO. 16 AWG ON .35" ID
Q1	DU2810S

Specifications Subject to Change Without Notice.