

9. DIMENSIONAL OUTLINE
9.1 DIMENSIONAL OUTLINE OF LCM

液晶之友 电话: 020-33819057
Http://www.lcdfriends.com

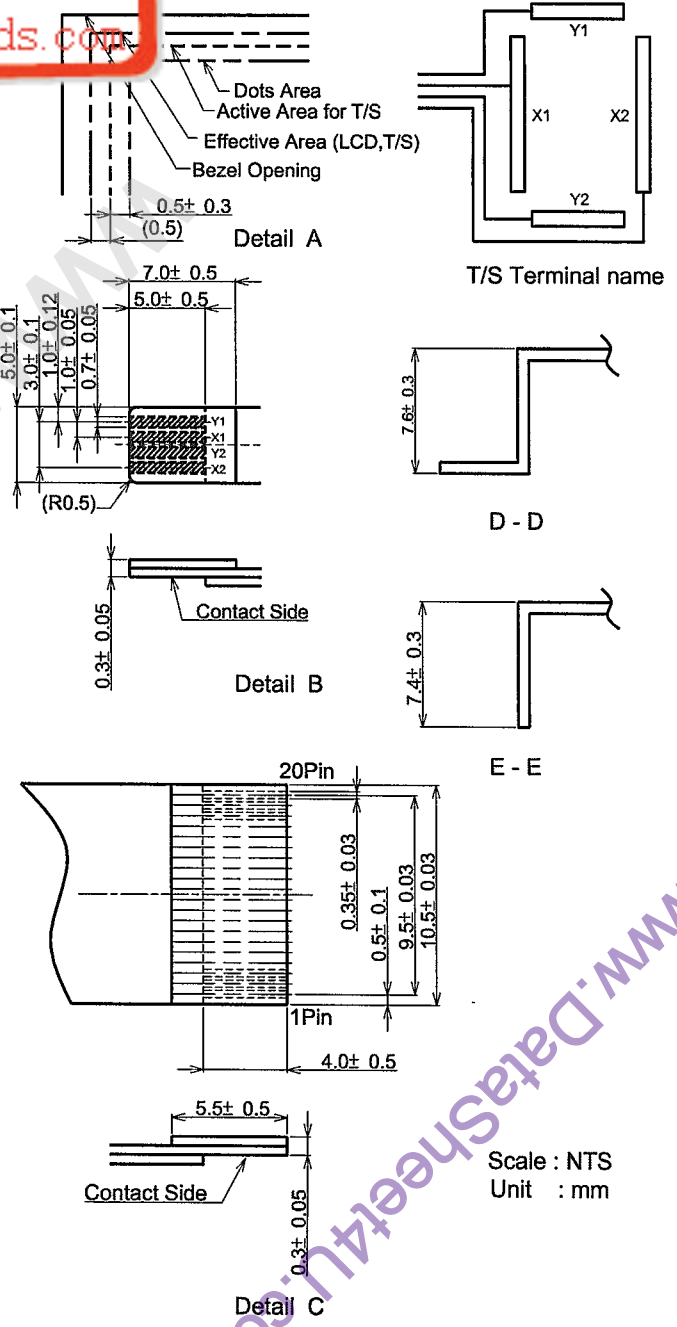
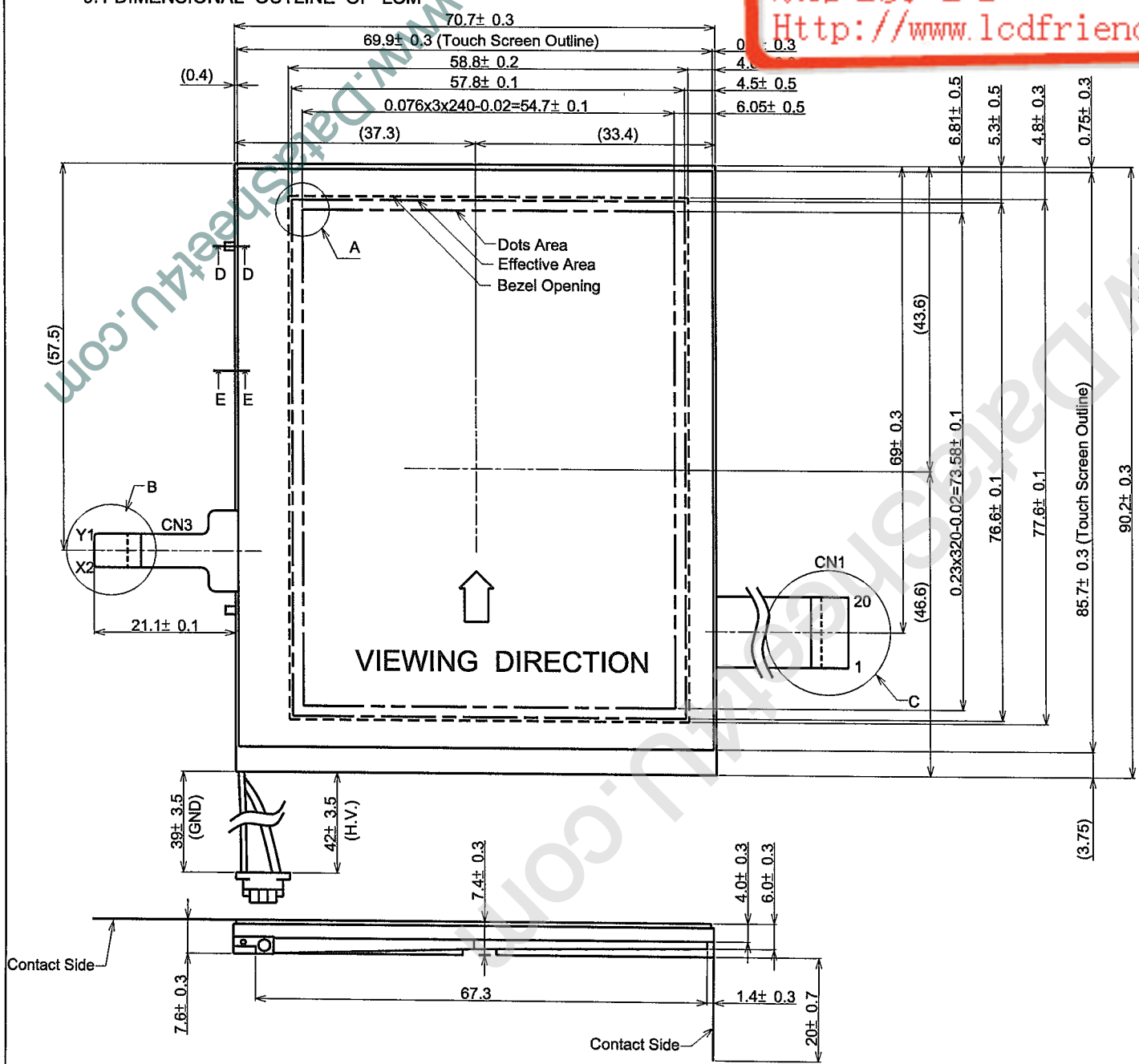

Scale : NTS
Unit : mm

HITACHI

KAOHSIUNG HITACHI
ELECTRONICS CO.,LTD
P.O. BOX 26-27
2,13TH EAST ST.K.E.P.Z.
KAOHSIUNG TAIWAN R.O.C.
TEL:(07) 8211101(10 LINE)
FAX:(07) 821-5860

FOR MESSRS : _____

DATE : Sep.27.2001

CUSTOMER'S ACCEPTANCE SPECIFICATIONS

SX09Q003-ZZA

C O N T E N T S

No.	ITEM	SHEET No.	PAGE
1	COVER	7B64PS 2701 - SX09Q003-ZZA-1	1-1/1
2	RECORD OF REVISION	7B64PS 2702 - SX09Q003-ZZA-1	2-1/1
3	GENERAL DATA	7B64PS 2703 - SX09Q00Z-ZZA-1	3-1/1
4	ABSOLUTE MAXIMUM RATINGS	7B64PS 2704 - SX09Q003-ZZA-1	4-1/1
5	ELECTRICAL CHARACTERISTICS	7B64PS 2705 - SX09Q003-ZZA-1	5-1/4~5-4/4
6	OPTICAL CHARACTERISTICS	7B64PS 2706 - SX09Q003-ZZA-1	6-1/3~6-3/3
7	BLOCK DIAGRAM	7B64PS 2707 - SX09Q003-ZZA-1	7-1/1
8	INTERFACE TIMING CHART	7B64PS 2708 - SX09Q003-ZZA-1	8-1/6~8-6/6
9	DIMENSIONAL OUTLINE	7B63PS 2709 - SX09Q003-ZZA-1	9-1/1
10	APPEARANCE STANDARD	7B64PS 2710 - SX09Q003-ZZA-1	10-1/5~10-5/5
11	PRECAUTION IN DESIGN	7B64PS 2711 - SX09Q003-ZZA-1	11-1/3~11-3/3
12	DESIGNATION OF LOT MARK	7B64PS 2712 - SX09Q003-ZZA-1	12-1/2~12-2/2
13	PRECAUTION FOR USE	7B64PS 2713 - SX09Q003-ZZA-1	13-1/1

*WHEN PRODUCT WILL BE DISCONTINUED, CUSTOMER WILL BE INFORMED
BY HITACHI WITH TWELVE MONTHS PRIOR ANNOUNCEMENT.

ACCEPTED BY: _____

PROPOSED BY: M. C. Chen

KAOHSIUNG HITACHI ELECTRONICS CO.,LTD.	Sh. No.	7B64PS 2701-SX09Q003-ZZA-1	PAGE	1-1/1
---	------------	----------------------------	------	-------

RECORD OF REVISION

DATE	SHEET No.	SUMMARY

3.GENERAL DATA

(1) Part Name	SX09Q003-ZZA
(2) Module Size	70.7(W)mmx90.2(H)mmx7.7max(D)mm
(3) Dot Pitch	0.076(W)mmx0.23(H)mm
(4) Number of Dots	240x3(R,G,B))(W)x320(H) dots
(5) Duty	1/323
(6) LCD	Color STN Transmissive type
(7) Viewing Direction	6 O'clock
(8) Backlight	Cold Cathode Fluorescent Tube (CFL) x 1
(9) Power Consumption(Total)	0.39W typ Except inverter
(10) Weight	71g typ
(11) Power Supply Voltage	VDD , VEE , V3 , V4 , V5 , V6
(12) Touch Screen	Resistance type

4. ABSOLUTE MAXIMUM RATINGS

4.1 ELECTRICAL ABSOLUTE MAXIMUM RATINGS (LCM)

VSS=0V:Standard

ITEM	SYMBOL	MIN.	MAX.	UNIT	COMMENT
Power Supply for Logic	VDD-VSS	0	7.0	V	
Power Supply for LCD	VEE-VSS	0	42.0	V	
Input Voltage	Vi	-0.3	VDD+0.3	V	Note 1
Input Current	Ii	0	1	A	
Static Electricity	-	-	-	-	Note 2

Note (1):DISP•OFF,FLM,CL1,CL2,D0~D7,M

Note (2):Make certain you are grounded when handling LCM

4.2 ELECTRICAL ABSOLUTE MAXIMUM RATINGS (TOUCH SCREEN)

ITEM	SPECIFICATION	NOTE
Supply Voltage	(7VDC) max	
Current	(3.5mA) max	

4.3 ENVIRONMENTAL ABSOLUTE MAXIMUM RATINGS

ITEM	OPERATING		STORAGE		COMMENT
	MIN.	MAX.	MIN.	MAX.	
Ambient Temperature	0°C	50°C	-20°C	60°C	Note 2,3,4
Humidity	Note 1		Note 1		Without condensation
Vibration	-	-	-	-	Depends on housing design.
Shock	-	-	-	-	Depends on housing design.
Corrosive Gas	Not Acceptable		Not Acceptable		

Note (1) $T_a \leq 40^\circ\text{C}$:85%RH max.

$T_a > 40^\circ\text{C}$:Absolute humidity must be lower than the humidity of 85%RH at 40°C .

Note (2) T_a at -20°C ----< 48h , at 60°C ----< 120h.

Note (3) Background color changes slightly depending on ambient temperature
This phenomenon is reversible.

Note (4) When LCM will be operated less than 5°C . The life time of CFL will be reduced
need to make sure of value of IL and characteristics of inverter , also the
response time less than 5°C will be slower.

5. ELECTRICAL CHARACTERISTICS

5.1 ELECTRICAL CHARACTERISTICS OF LCD

VSS=0V

I T E M	SYMBOL	CONDITION	MIN.	TYP.	MAX.	UNIT
Power Supply Voltage	VDD	VDD-VSS=3.3V	2.70	3.30	5.50	V
Input Voltage for Logic Circuits (Note 1)	Vi	"H" level	0.8VDD	-	VDD	V
		"L" level	0	-	0.2VDD	
Power Supply Current (Note 2, 3)	IDD	VDD-VSS=3.3V	-	0.5	-	mA
	IEE	VEE=28.5V	-	1.4	-	
Operating Voltage	VEE	Ta= 0°C , φ=0°	29.1	30.1	31.1	V
		Ta=25°C , φ=0°	27.5	28.5	29.5	
		Ta=40°C . φ=0°	26.8	27.8	28.8	
Frame Frequency (Note 4)	fFLM	-	60	70	80	Hz

(Note 1) DISP • OFF ,FLM ,CL1 ,CL2 ,D0~D7 ,M

(Note 2) fFLM=70Hz Ta=25°C, Display pattern : Checker pattern.

(Note 3) Rush Current of Power ON : 200mA (PK)x100 μs

(Note 4) Need to make sure of flickering and rippling of display when setting the frame frequency and msignal frequency in your set.

5.2 ELECTRICAL CHARACTERISTICS OF TOUCH SCREEN

5.2.1 OPERATING CONDITION

ITEM	SPECIFICATION
Operating Voltage	5VDC
Operating Current	1A max

5.2.2 ELECTRICAL CHARACTERISTICS

ITEM		SPECIFICATION	NOTE
Resistance between terminal	X1-X2	270~570Ω	
	Y1-Y2	420~1020Ω	
Insulance Resistance	X-Y	5MΩ min.	Operating Voltage : 25V DC
Linearity	X	1.5% max.	Condition See (Note 1)
	Y	1.5% max.	

5.2.3 MECHANICAL CHARACTERISTICS

ITEM	SPECIFICATION	NOTE
Pen input pressure	1N max	
Surface hardness	3H min.	JIS K5400

5.2.4 OPTICAL CHARACTERISTICS

ITEM	SPECIFICATION	NOTE
Transparency	80% min	

(Note 1) : Definition of linearity

In Fig.1 , when the DC5V is impressed between the "X" directional electrode and "Y" directional of table alternately , the voltage between the depressed point and the reference surface shall be the output voltage (Eox and Eoy). As shown in Fig.2 , measure the point on 10mm grid enclosed by the positions "A" and "B", which are located at the inside of visible area the specified distance away from the edge, has been depressed.

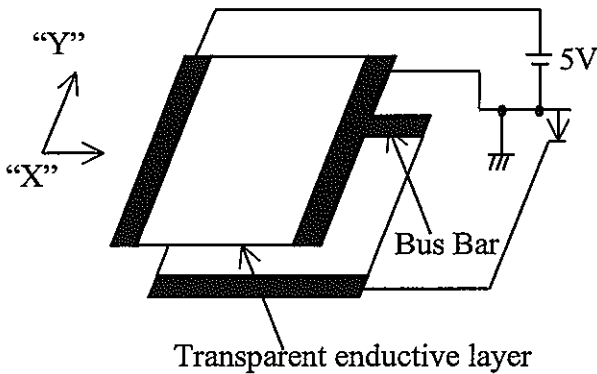

<Fig.1>

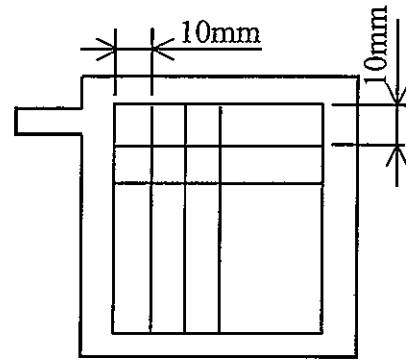

<Fig.2>

When the output voltage corresponding to every measurement position is plotted as shown in Fig3 , the difference between the voltage enclosed by the positions "A" and "B" and the output voltage at the same position shall be " ΔE_x " (or " ΔE_y ") and the electric potential difference "EABx" (or "EABy) between "A" and "B" shall be defined as the linearity.

$$\text{Linearity of transparent table (X)} = (\Delta E_x / E_{ABx}) \times 100\%$$

$$\text{Linearity of transparent table (Y)} = (\Delta E_y / E_{ABy}) \times 100\%$$

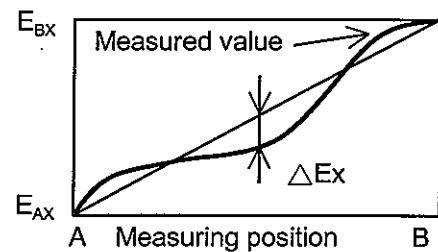
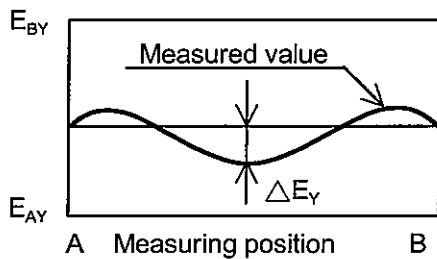

<Fig.3>

Measurement of linearity

A measured value shall be a maximum value in absolute value tolerance when every point on a grid shown in Fig4 has been pressed.

<Hitting conditions> Load : 0.8N

Measuring jig : 0.8R resin pen

Measuring area : 5x7

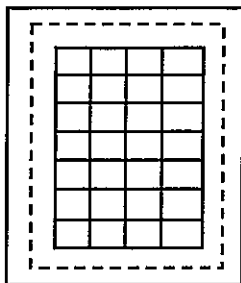

<Fig.4>

5.3 ELECTRICAL CHARACTERISTICS OF BACKLIGHT

ITEM	SYMBOL	MIN	TYP	MAX	UNIT	NOTE
Lamp Voltage	VL	(250)	(280)	(310)	Vrms	Ta=25°C
Frequency	fL	(50)	-	-	kHz	
Lamp Current (1Lamp)(Note 7,8)	IL	(Note9) (0.5)	1.25	(2.0)	mA	Ta=25°C
Stabilization Voltage	VLS (Note 2)	(830)	-	-	Vrms	Ta=0°C
		(595)	-	-		Ta=25°C

(Note 1) Please design your lamp driving circuit (inverter) according to the above specifications, and inform Hitachi of it.

(Note 2) Starting discharge voltage is increased when LCM is operating at low temperature.

Please check the characteristics of your inverter before applying to your set.

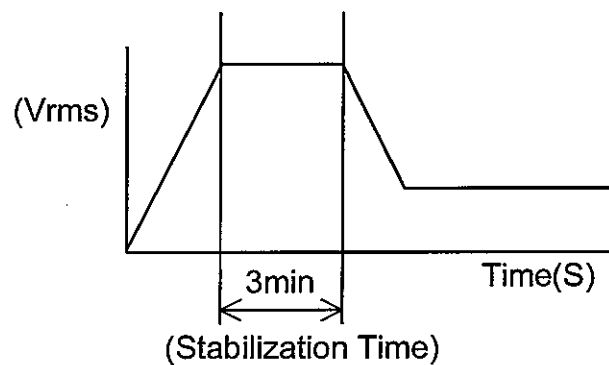

(Note 3) Average life time of CFL will be decreased when LCM is operating at low temperature.

(Note 4) Under lower driving frequency of an inverter, a certain backlight system (CFL & CFL reflection sheet) may generate a sound noise. Before designing the inverter, please consider the driving frequency and noise.

(Note 5) When IL is over 3.0mA, it may cause uneven contrast near CFL location, due to heat dispersion form CFL.

(Note 6) Absolute maximum ratings voltage of CFL cable for this module is as follows.
VCF side : 2kV
VSS side : 300V

This inverter design shall not exceed the rated voltage.

(Note 7) We suggest that the lamp current can not be lower than the standard of CAS set, or it will cause low brightness.

(Note 8) The brightness of the CFL in this LCM may deteriorate after the long-hour use under ICFL=1.25mA. However, it will recover when the CFL is lighted at ICFL=2.0mA min. 5 minutes or more.

(Note 9) Except at starting up.

6. OPTICAL CHARACTERISTICS

6.1 OPTICAL CHARACTERISTICS OF LCD

Ta=25°C (Backlight on)

ITEM		SYMBOL	CONDITION	MIN.	TYP.	MAX.	UNIT	NOTE
Viewing area		$\phi 2-\phi 1$	$\theta=0^\circ, K \geq 2.0$	-	(40)	-	deg	1,2
Contrast ratio		K	$\phi=0^\circ, \theta=0^\circ$	(30)	(45)	-	-	3,5,6
Response time (rise)		tr	$\phi=0^\circ, \theta=0^\circ$	-	(250)	-	ms	4
Response time (fall)		tf	$\phi=0^\circ, \theta=0^\circ$	-	(150)	-	ms	4
Color tone (Primary Color)	Red	x	$\phi=0^\circ, \theta=0^\circ$	0.48	0.53	0.58	-	7
		y		0.26	0.31	0.36	-	
	Green	x		0.25	0.30	0.35	-	
		y		0.50	0.55	0.60	-	
	Blue	x		0.11	0.16	0.21	-	
		y		0.12	0.17	0.22	-	
	White	x		0.25	0.30	0.35	-	
		y		0.30	0.35	0.40	-	

(Measurement condition : Hitachi standard)

Note 1)~7) : See next page.

Note 1. Definition of θ and ϕ (Normal)

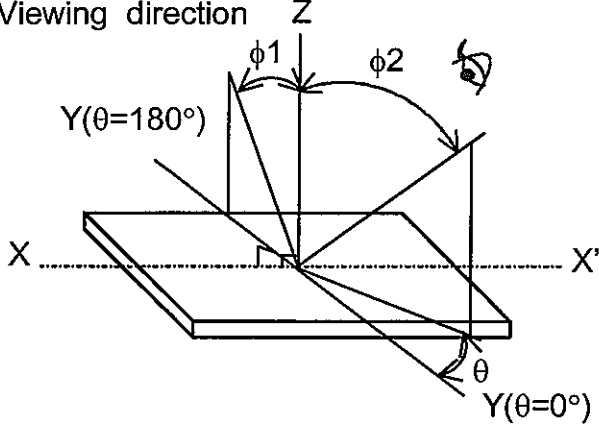

Note 3. Definition of contrast "K"

$$K = \frac{\text{Brightness of selected area (B1)}}{\text{Brightness of non-selected area (B2)}}$$

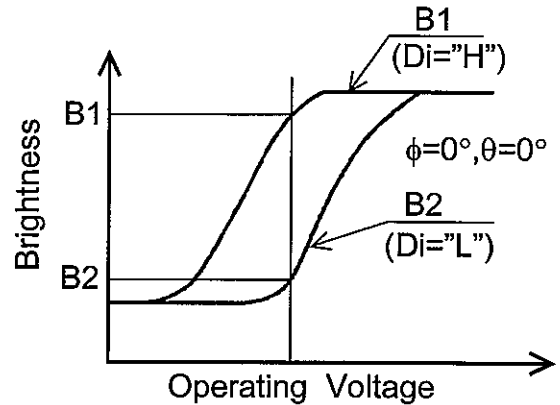

Note 2. Definition of viewing angle $\phi 1$ and $\phi 2$

$$\phi 1 < 0^\circ < \phi 2$$

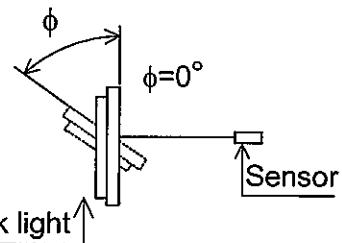
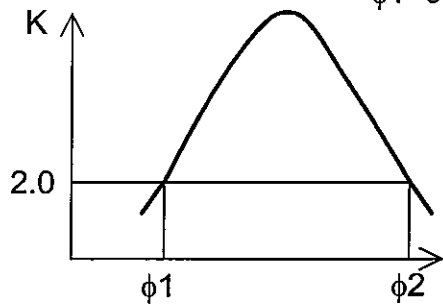

Sensor : BM-7

Aperture : 1°

Distance : 0.4m

Contrast ratio k vs viewing angle ϕ

Note 4. Definition of optical response time

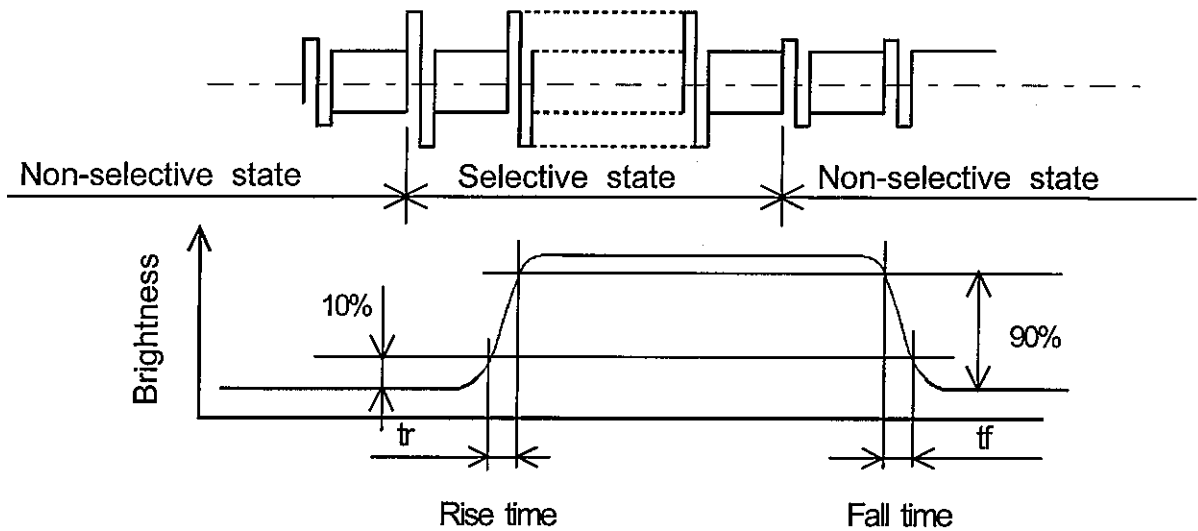

Note 5. Hitachi will not do 100% inspection for minimum value. Minimum value is for reference.

Note 6 Hitachi will do sampling inspection for minimum value.

Note 7 The LCD driving voltage should be adjusted at the voltage where the peak contrast is obtained.

6.2 OPTICAL CHARACTERISTICS OF BACKLIGHT

ITEM	MIN.	TYP.	MAX.	UNIT	NOTE
Brightness	(40)	50	-	cd/m ²	IL=1.25mA Note1),2)
Rise time	-	5	-	Minute	IL=1.25mA Brightness 80%
Brightness uniformity	-	-	(± 20)	%	Undermentioned Note 1),3)

(Measurement condition : Hitachi standard)

CFL: INITIAL, Ta=25°C

Display data should all be "ON"

The LCD driving voltage should be adjusted so as to obtain maximum contrast when display pattern is all "Q".

(Note 1) Measurement after 10 minutes from CFL operating.

Average value of 9 points (Note 3)

(Note 2) Brightness control : 100%.

(Note 3) Measurement of the following 9 places on the display.

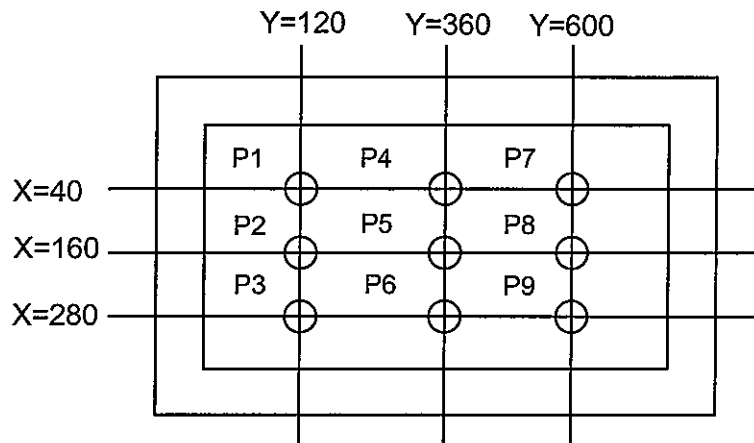

(Note 4) Definition of the brightness tolerance.

$$\left(\frac{\text{Max brightness or Min brightness} - \text{Average brightness}}{\text{Average brightness}} \right) \times 100$$

7. BLOCK DIAGRAM

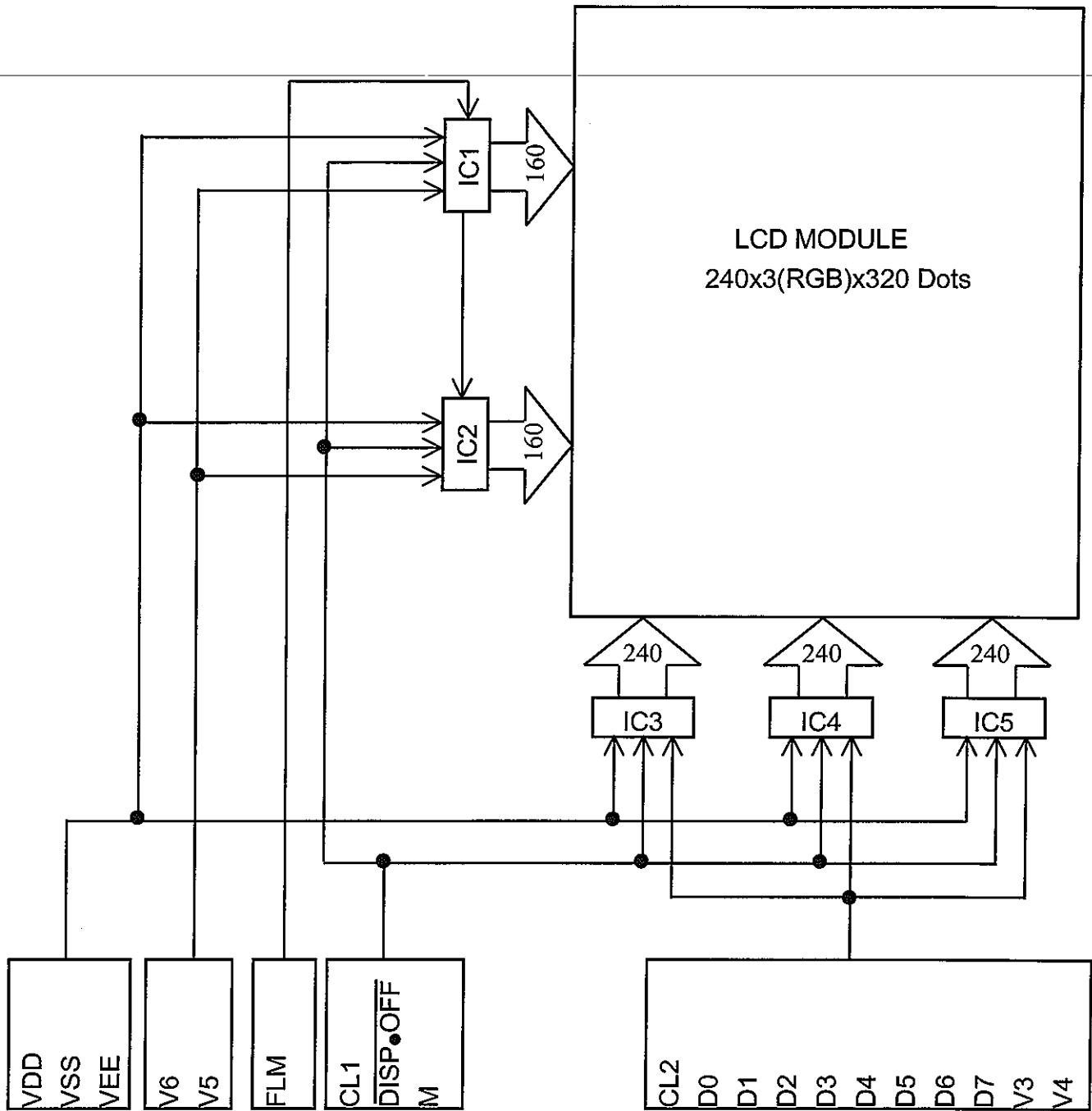

Note (1) Controller and bias voltage supply circuit are not included.

(2) VEE , VSS , V3 , V4 , V5 and V6 are power supply voltage for LCD.
 (VEE ≥ V6 ≥ V3 ≥ V4 ≥ V5 ≥ VSS)

8.INTERFACE TIMING CHART
8.1 TIMING CHART

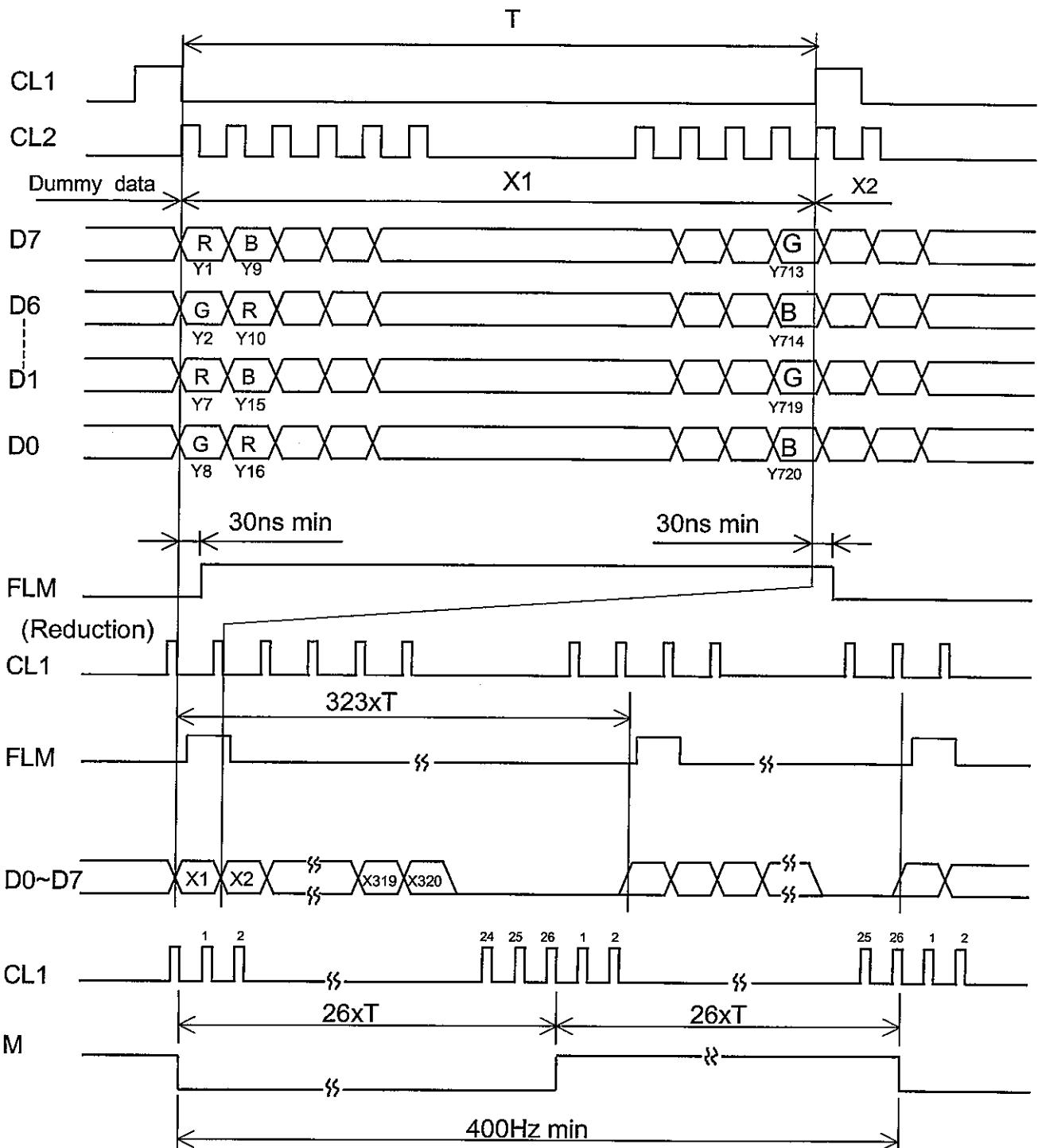

Note 1. M signal should be kept 400Hz min. and 50% duty.
Note 2. Hitachi recommend 26xCL1 pulses of M signal 50%.

8.2 TIMING CHARACTERISTICS

VDD=2.7~5.5V, VSS=0V, Ta=0°C~+50°C

ITEM	SYMBOL	MIN.	TYP.	MAX.	UMIT
CL1 pulse width "H"	t _{WHCL1}	50	-	-	ns
CL1 pulse width "L"	t _{WHCL1}	370	-	-	ns
Clock cycle time	t _{CYC}	100	-	-	ns
CL2 pulse width	t _{WCL2}	37	-	-	ns
Clock set up time	t _{SCL1}	100	-	-	ns
Clock hold time	t _{HCL1}	100	-	-	ns
Clock rise fall time	t _r , t _f	-	-	30	ns
Data set up time	t _{DSU}	35	-	-	ns
Data hold time	t _{DH}	35	-	-	ns
"FLM" set up time	t _{FS}	100	-	-	ns
"FLM" hold time	t _{FH}	30	-	-	ns
M delay time	t _M	-	-	300	ns

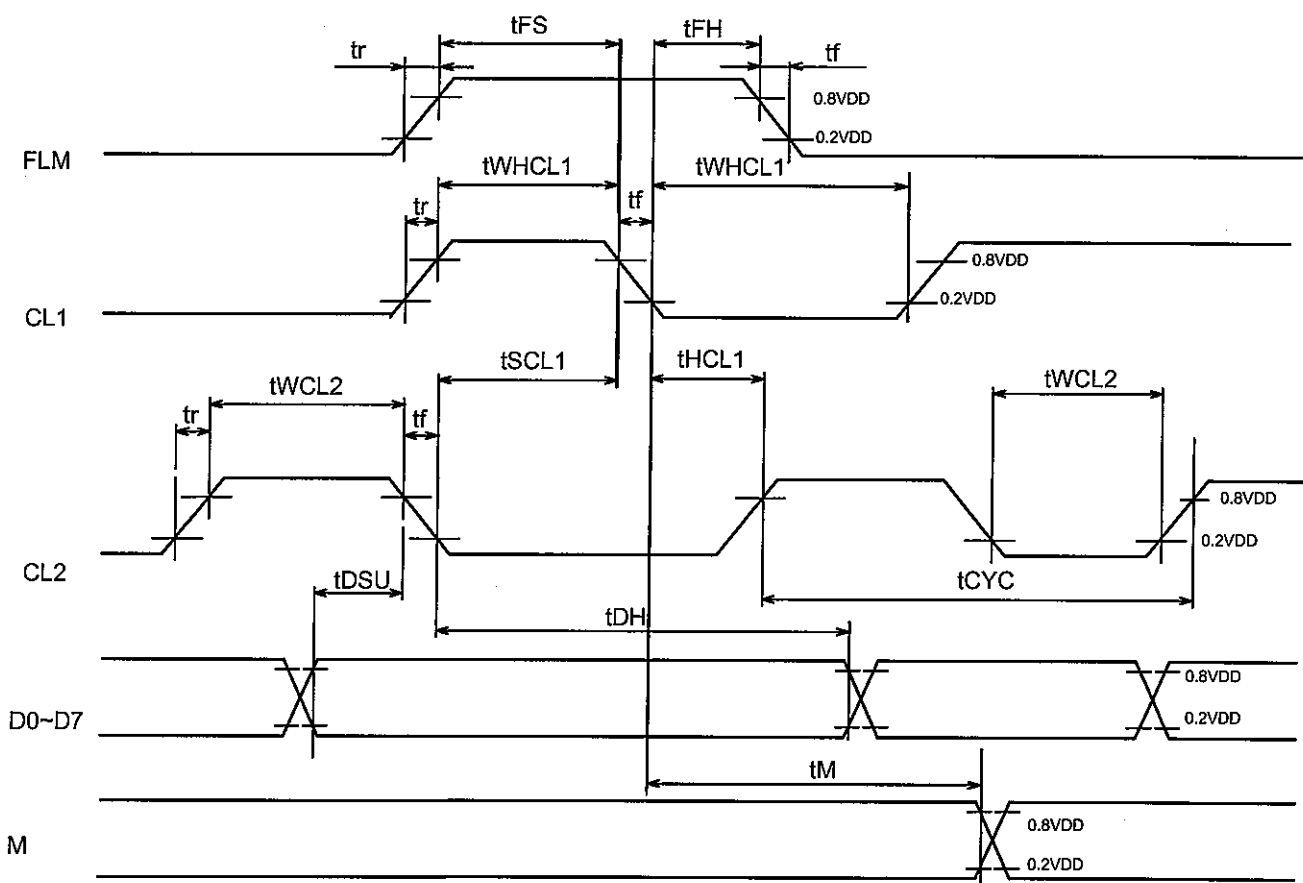

8.3 POWER ON/OFF SEQUENCE

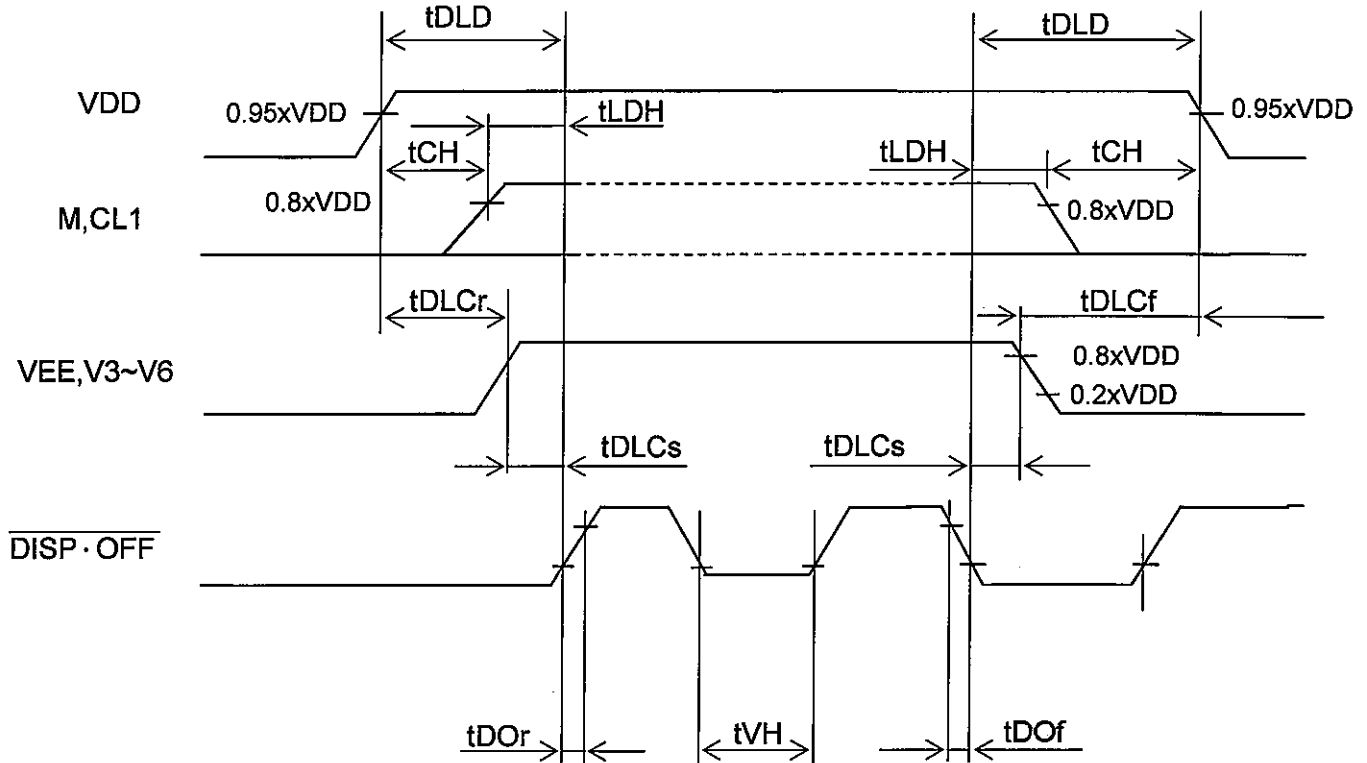

SYMBOL	MIN	MAX	UNIT	COMMENT
t_{DLD}	200	-	ms	(Note 1)
t_{CH}	0	-	ms	
t_{LDH}	0	-	ms	
t_{DOr}	-	100	ns	(Note 2)
t_{DOF}	-	100	ns	
t_{DLCr}	20	-	ms	
t_{DLCf}	0	-	ms	
t_{DLCs}	20	-	ms	
t_{VH}	200	-	ms	

(Note 1) Please keep the specified sequence because wrong sequence may cause permanent damage to the LCD panel.

(Note 2) Hitachi recommends you to use DISP•OFF function.

Display quality may deteriorate if you don't use DISP•OFF function.

8.4 POWER SUPPLY FOR LCM

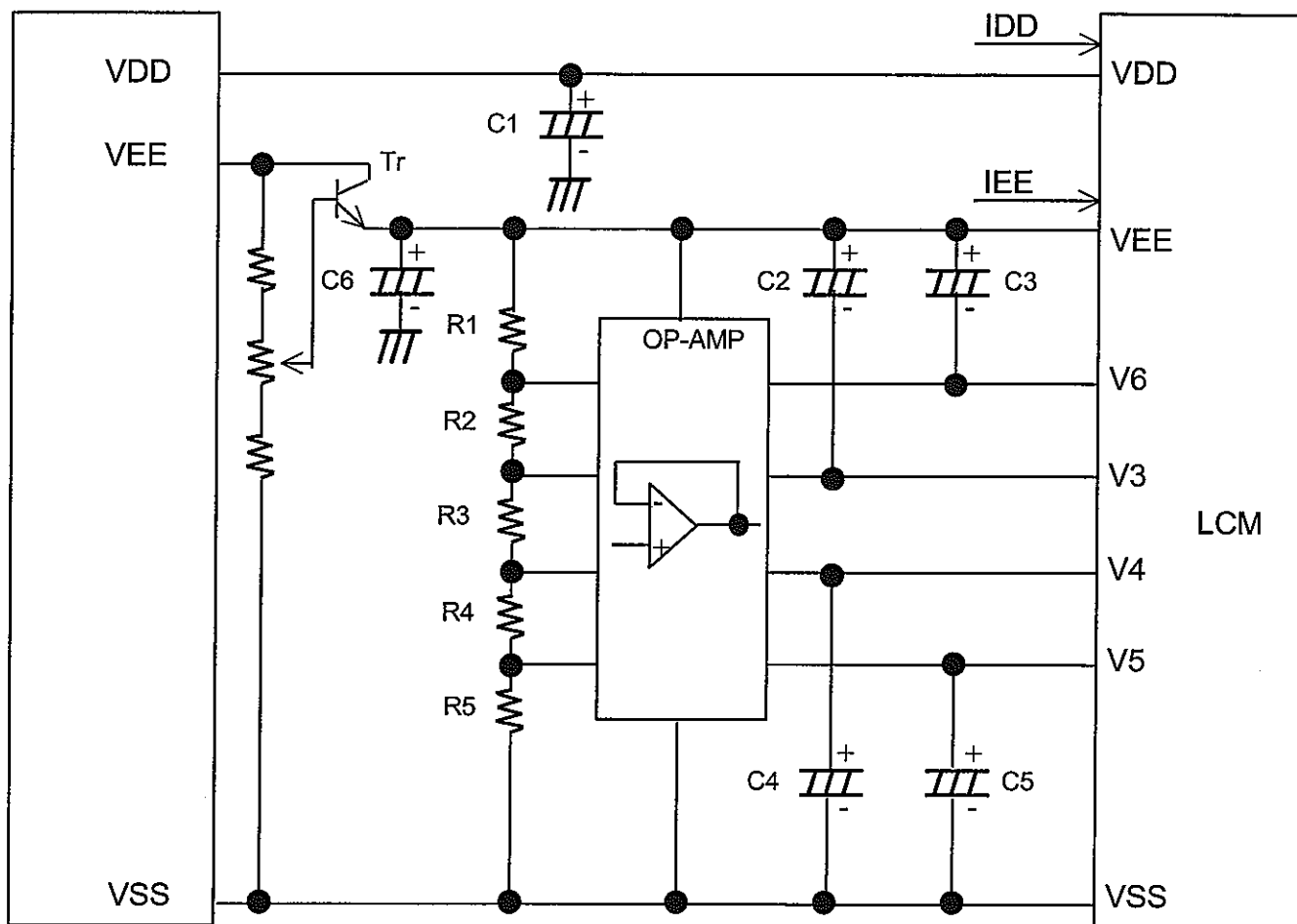

- $R1=R2=R4=R5 : (3k\Omega \pm 0.1\%)$
 $R3 : (n \times R1k\Omega)$
 $C1 \sim C6 : (3.3\mu F \sim 4.7\mu F)$
 $Tr : (2SD1368)$

8.5 INPUT DATA ALLOCATION TABLE

Data Signal	D	D	D	D	D	D	D	D	D	D	D	D	-----	D	D	D	D	D
	7	6	5	4	3	2	1	0	7	6	5	4		4	3	2	1	0
Y	1	2	3	4	5	6	7	8	9	10	11	12	-----	7	7	7	7	7
X														6	7	8	9	0
1	R	G	B	R	G	B	R	G	B	R	G	B	-----	G	B	R	G	B
2	R	G	B	R	G	B	R	G	B	R	G	B	-----	G	B	R	G	B
3	R	G	B	R	G	B	R	G	B	R	G	B	-----	G	B	R	G	B
4	R	G	B	R	G	B	R	G	B	R	G	B	-----	G	B	R	G	B
5	R	G	B	R	G	B	R	G	B	R	G	B	-----	G	B	R	G	B

138	R	G	B	R	G	B	R	G	B	R	G	B	-----	G	B	R	G	B
139	R	G	B	R	G	B	R	G	B	R	G	B	-----	G	B	R	G	B
140	R	G	B	R	G	B	R	G	B	R	G	B	-----	G	B	R	G	B
141	R	G	B	R	G	B	R	G	B	R	G	B	-----	G	B	R	G	B
142	R	G	B	R	G	B	R	G	B	R	G	B	-----	G	B	R	G	B
143	R	G	B	R	G	B	R	G	B	R	G	B	-----	G	B	R	G	B
144	R	G	B	R	G	B	R	G	B	R	G	B	-----	G	B	R	G	B
145	R	G	B	R	G	B	R	G	B	R	G	B	-----	G	B	R	G	B

318	R	G	B	R	G	B	R	G	B	R	G	B	-----	G	B	R	G	B
319	R	G	B	R	G	B	R	G	B	R	G	B	-----	G	B	R	G	B
320	R	G	B	R	G	B	R	G	B	R	G	B	-----	G	B	R	G	B

R : RED
 G : GREEN
 B : BLUE

8.6 INTERNAL PIN CONNECTION

CN1

PIN No.	SIGNAL	LEVEL	FUNCTION
1	VSS	-	GND
2	D0	H / L	Display Data
3	D1		
4	D2		
5	D3		
6	D4		
7	D5		
8	D6		
9	D7		
10	VDD	-	Power Supply for Logic
11	VEE	-	Power Supply for LCD
12	V6	-	Bias Voltage for non-select (Common driver)
13	V3	-	Bias Voltage for non-select (Segment driver)
14	V4	-	Bias Voltage for non-select (Segment driver)
15	V5	-	Bias Voltage for non-select (Common driver)
16	DISP•OFF	H / L	H : ON / L : OFF
17	CL2	H→L	Data Shift
18	M	H / L	AC Signal Input for LCD Drive Waveform
19	CL1	H→L	Data Latch
20	FLM	H	First Line Marker

CN2 FCL JST housing : BHR-02VS-1 (Suitable Connector : JST SM02(4.0)B-BHS-1)
Contact pin : SBH-001T-P0.5

PIN No.	SIGNAL	LEVEL	FUNCTION
1	VSS	-	GND for CFL
2	VCFL	-	Power Supply for CFL

CN3 Touch Screen Flat Cable (1.0mm pitch)

PIN No.	SIGNAL	LEVEL	FUNCTION
1	X2	-	Analog Signal from Digitizer
2	Y2		
3	X1		
4	Y1		

9. DIMENSIONAL OUTLINE
9.1 DIMENSIONAL OUTLINE OF LCM

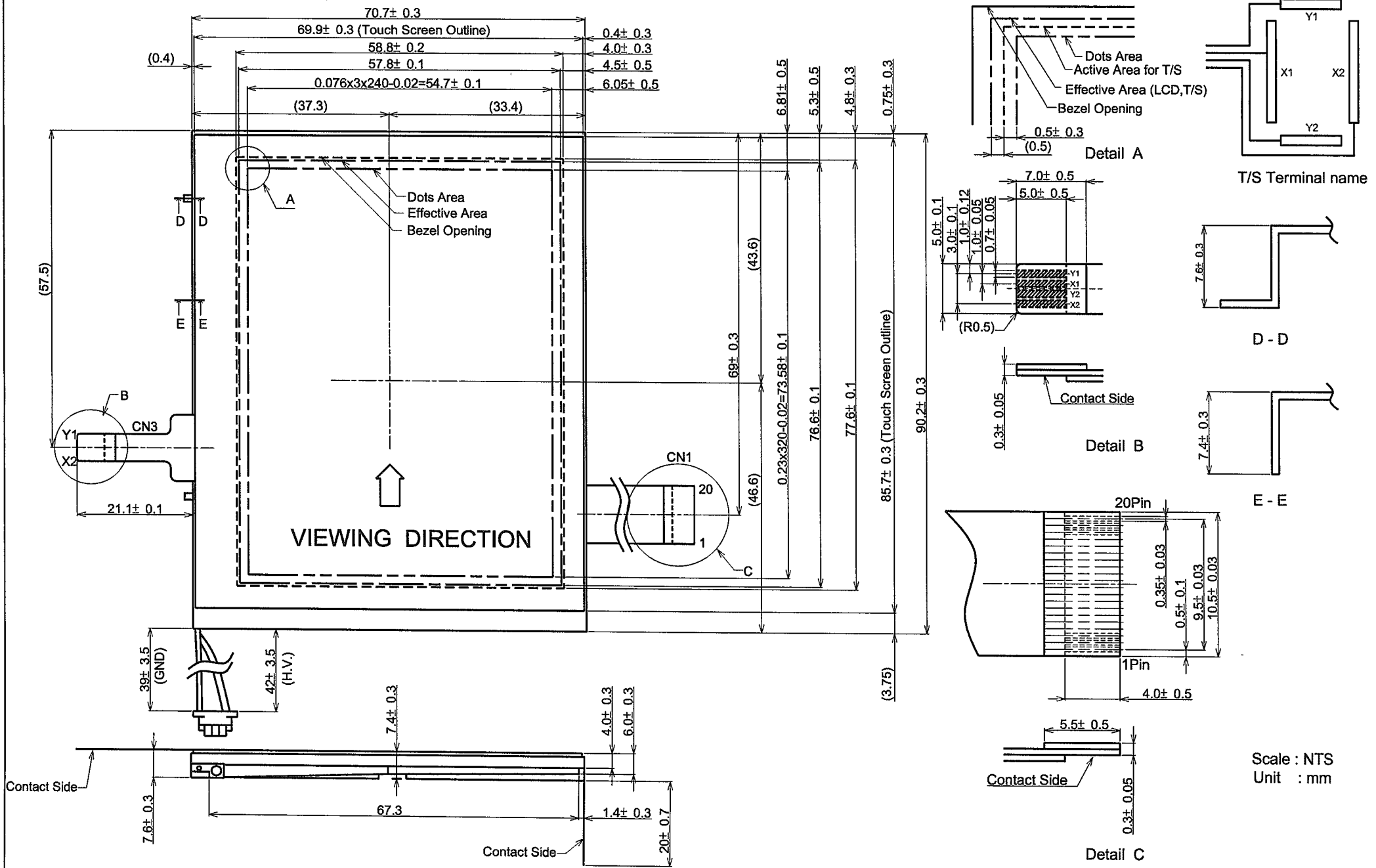

10. APPEARANCE STANDARD

10.1.1 APPEARANCE INSPECTION CONDITION

Visual inspection should be done under the following condition.

- (1) The inspection should be done in a dark room.
- (2) The CFL should be lighted with the prescribed inverter.
- (3) The distance between eyes of an inspector and the LCD module is 25cm.
- (4) The viewing zone is shown the figure.

Viewing angle $\leq 25^\circ$.

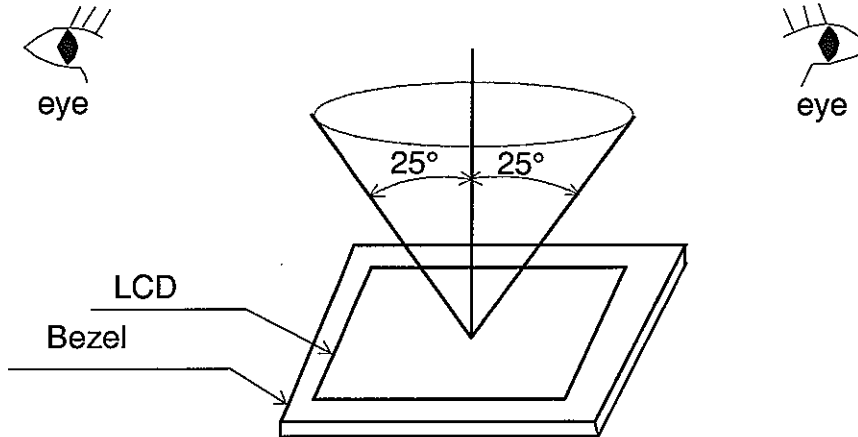

10.2 DEFINITION OF ZONE

A zone : The dots area specified at page 9-1/1 of this document.

B zone : Area between the effective display area line and the dots area (A zone) line specified at page 9-1/1 of this document.

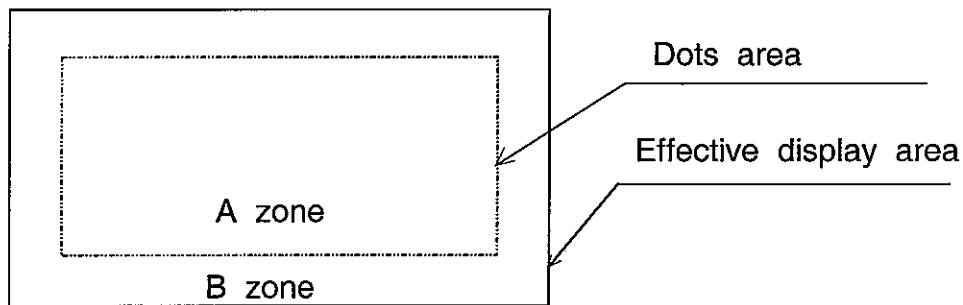

10.3 APPEARENCE SPECIFICATION

(1)LCD APPEARANCE

* If the problem related to this section occurs about this item , the responsible persons of both party (Customer and Hitachi) will discuss the matter in detail.

No.	ITEM	CRITERIA			APPLIED ZONE
	Scratches	Distinguished one is not acceptable (To be judged by HITACHI standard)			A
	Dent	Same as above			A
	Wrinkles in Polarizer	Same as above			A
	Bubbles	Average diameter D(mm)		Maximum Acceptable number	A
		D \leq 0.2		ignored	
		0.2<D \leq 0.3		12	
		0.3<D \leq 0.5		3	
		0.5<D		none	
L C D	Stains, Foreign Materials	Filamentous (Line shape)			A
		Length L(mm)	Width W(mm)	Maximum acceptable number	
	L \leq 2.0	W \leq 0.03	ignored		
	L \leq 3.0	0.03<W \leq 0.05	6		
	L \leq 2.5	0.05<W \leq 0.1	1		
	Dark spot	Round(Dot shape)			A
		Average diameter D(mm)	Maximum acceptable number	Minimum Space	
		D<0.2	ignored	-	
		0.2 \leq D<0.3	10	10 mm	
		0.3 \leq D<0.4	5	30 mm	
0.4 \leq D		none	-		
The total number		Filamentous+Round=10			
Those wiped out easily are acceptable					
	Color tone	To be judged by HITACHI standard			A
	Color uniformity	Same as above			A

No.	ITEM	CRITERIA				APPLIED ZONE
L	Contrast irregularity (Spot)	Average diameter D(mm)	Contrast	Maximum acceptable number	Minimum space	A
		$D \leq 0.25$	To be	ignored	-	
		$0.25 < D \leq 0.35$	Judged by	10	20mm	
		$0.35 < D \leq 0.5$	HITACHI	4	20mm	
		$0.5 < D \leq 0.7$	standard	3	50mm	
	$0.7 < D$		None	-		
C	Contrast irregularity (Line) (A pair of scratches)	Width W(mm)	Length L(mm)	Maximum Acceptable number	Minimum space	A
D		$W \leq 0.25$	$L \leq 1.2$	2	20mm	
		$W \leq 0.2$	$L \leq 1.5$	3	20mm	
		$W \leq 0.15$	$L \leq 2.0$	3	20mm	
		$W \leq 0.1$	$L \leq 3.0$	4	20mm	
	The whole number		6			
	Rubbing Scratch	To be judged by HITACHI standard				-

(2) CFL BACKLIGHT APPEARANCE

No.	ITEM	CRITERIA			APPLIED ZONE	
C F L	Dark spots White spots Foreign materials (Spot)	Average diameter D(mm)	Maximum Acceptable number		A	
		$D \leq 0.4$	ignored			
		$0.4 < D$	none			
B A C K L I G H T	Foreign materials (Line)	Width W(mm)	Length L(mm)	Maximum Acceptable number	A	
		$W \leq 0.2$	$L \leq 2.5$	1		
		$2.5 < L$	None			
	$0.2 < W$	-		none		
S C R A T C H E S	Scratches	Width W(mm)	Length L(mm)	Maximum acceptable number	A	
		$W \leq 0.1$	-			ignored
		$0.1 < W \leq 0.2$	$L \leq 11.0$	1		
		$11.0 < L$	None			
	$0.2 < W$	-		none		

(3) TOUCH PANEL APPEARANCE

Item	CRITERIA		
	Scratch	$W > 0.1$	$L > 12$
$0.10 \geq W > 0.05$		$L \leq 12$	5 or less for ok
$0.05 \geq W$		$L \leq 12$	ignored
Dust(Linear)	$W > 0.10$	$L > 2$	None
	$0.10 \geq W > 0.05$	$L \leq 5$	3 or less for ok
	$0.05 \geq W$	$L \leq 12$	ignored
Dust(Circular)	$D > 0.3$		None
	$0.3 \geq D > 0.1$		5 or less for ok
	$D \leq 0.1$		ignored

Applied only in the active area. Scratches or dusts in the outside of the active area are acceptable unless the electrical characteristics are affected.

- Dirt

Acceptable if not noticeable on a black mat.

- Interference Fringes (Newton Rings) must not be recognized under 3wavelength fluorescent light.
- Tip, crack (applicable to glass only)

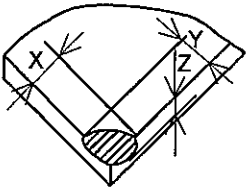
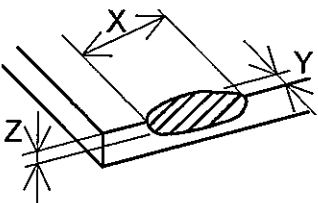
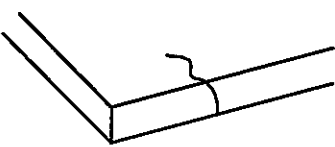
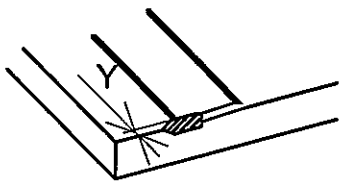
Item	CRITERIA			
	Tip Corner		X	≤ 2.5
Y			≤ 2.5	
Z			≤ 1.1	
Tip Side		X	≤ 5	Not acceptable if the film is damaged
		Y	≤ 3	
		Z	≤ 1.1	
Crack				None
Other			$Y \leq 1$	Not acceptable if the electrical Characteristics is affected

Note (1) Definition of average diameter (D)

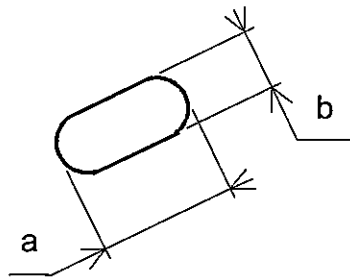

$$D = \frac{a+b}{2}$$

Note (2) Definition of length (L) and width (W)

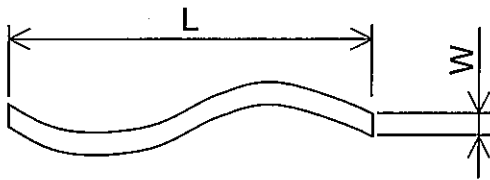

11. PRECAUTION IN DESIGN

11.1 MOUNTING PRECAUTION

(1) When assembling the touch panel and you case, please refer to the figure below.

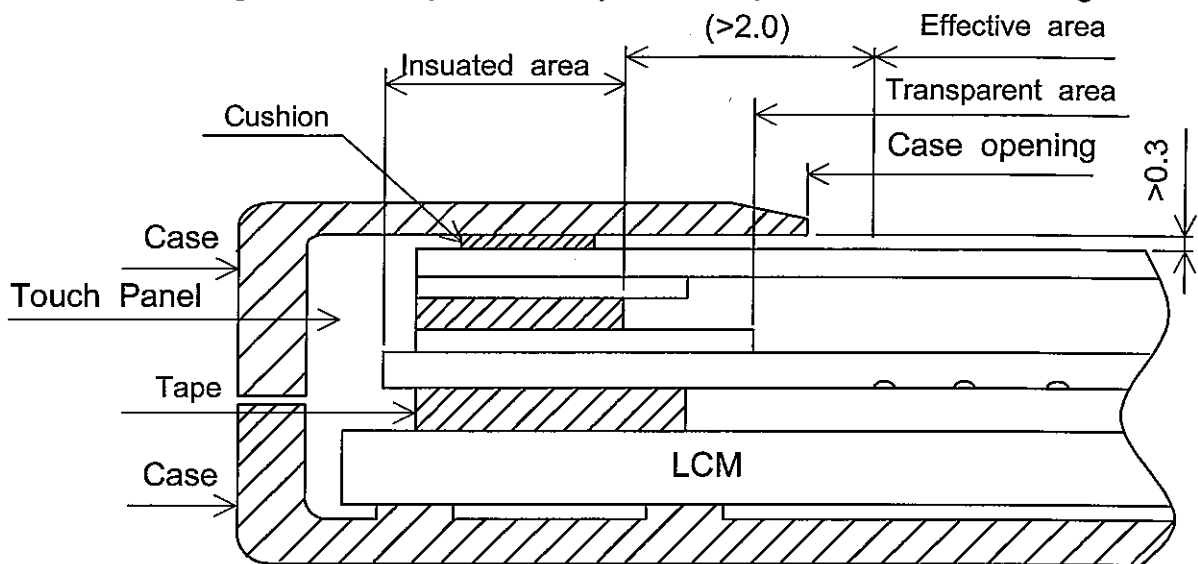

- (2) The clearance between the touch panel and case shall be designed so that the case edge never presses the input screen when it is deformed by heat or other causes.
- (3) The case shall be designed not to touch the tail portion (FPC for touch panel).
- (4) The boundary space between the effective area and the insulated area is unstable. Touching this area may effect the operation of the touch panel. The case must be designed so that it does not touch the boundary space.

11.2 PRECAUTIONS AGAINST ELECTROSTATIC DISCHARGE

As this module contains C-MOS LSIs, it is not strong against electrostatic discharge. Make certain that the operator's body is connected to the ground through a list band etc.

And don't touch I/F pins directly.

11.3 POWER ON SEQUENCE

Input signals should not be applied to LCD module before power supply voltage is applied and reaches to specified voltage.

If the above sequence is not kept, C-MOS LSIs of LCD module may be damaged due to latch up phenomenon.

11.4 HANDLING PRECAUTIONS

- (1) Since the polarizer on the top, and the aluminum plate on the bottom tend to be easily damaged, they should be with full care so as not to get them touched, pushed or rubbed by a piece on glass, tweezers and anything else which are harder a pencil lead 3H.

(2) As the adhesives used for adhering upper/lower polarizers and aluminum plate are made of organic substances which will be deteriorated by a chemical reaction with such chemicals as acetone, toluene, ethanol and isopropylalcohol. The following are recommended for use : Normal hexane

Please contact us when it is necessary for you to use chemicals other than The above.

(3) Lightly wipe to clean the dirty surface with absorbent cotton or other soft material like chamois, soaked in the recommended chemicals without scrubbing it hardly.

Always wipe the surface horizontally or vertically. Never give a wipe in a circle. To prevent the display surface from damage and keep the appearance in good state, it is sufficient, in general, to wipe it with absorbent cotton.

(4) Immediately wipe off saliva or water drop attached on the display area because it may cause deformation or faded color.

(5) Foggy dew deposited on the surface may cause a damage, stain or dirt to the polarizer.

When you need to take out the LCD module from some place at low temperature for test, etc.

It is required to be warmed them up to temperature higher than room temperature before taking them out.

(6) Touching the display area or I/F pins with bare hands or contaminating them are prohibited, because the stain on the display area and poor insulation between terminals are often caused by being touched with bare hands.

(Some cosmetics are detrimental to polarizers.)

(7) In general, the glass is fragile so that, especially on its periphery, tends to be cracked or chipped in handling. Please not give the LCD module sharp shocks by falling etc.

(8) Maximum pressure to the surface must be less than 1.96×10^4 Pa.

And if the pressure area is less than 1cm^2 , maximum pressure must be less than 1.96N.

(9) Since the metal width is narrow on these locations (see page 9-1/1), please careful with handling.

(10) Top sheets shall be cleaned gently using a soft cloth such as those used for glasses.

Hard wiping accumulated dust will leave scars on the surface even using a cloth.

11.5 OPERATION PRECAUTION

(1) Using a LCM module beyond its maximum ratings may result in its permanent destruction.

LCM module's should usually be used under recommended operating conditions shown in chapter 5. Exceeding any of these conditions may adversely affect its reliability.

- (2) Response time will be extremely delayed at lower temperature than the specified operating temperature range and on the other hand LCD's shows dark blue at higher temperature.
How ever those phenomena do not mean defects of the LCD module. Those phenomena will disappear in the specified operating temperature range.
- (3) If the display area is pushed hard during operation, some display patterns will be abnormally displayed.
- (4) A slight dew depositing on terminals may cause electrochemical reaction which leads to terminal open circuit. Please operate the LCD module under the relative condition of 40°C 85%RH.
- (5) Resistance range : Your controller shall be set up to allow the resistance range of touch panel specified in our CAS.
- (6) Pointed position of touch panel may shift owing to a change in resistance of touch panel depending on the operation condition . To compensate this shift, the set shall be given a calibration function.
- (7) Input shall be made with a stylus pen (polyacetal , R0.8). Chances are very high that use of a metal piece including a ball point pen or sharp edge will impair accuracy.
- (8) The touch panel is an auxiliary input device. The system shall be designed to have other input device.

11.6 STORAGE

In case of storing LCD module for a long period of time (for instance, for years) for The purpose of replacement use, the following precautions necessary.

- (1) Store the LCD modules in a dark place; do not expose them to sunlight or ultraviolet rays.
- (2) Keep the temperature between 10°C and 35°C at normal humidity.
- (3) Store the LCD modules in the container which is used for shipping from us.
- (4) No articles shall be left on the surface over an extended period of time.

11.7 SAFETY

The LCD modules include Cold Cathode Fluorescent Lamp(CFL). CFL contains a small amount of mercury. Please follow local ordinances or regulations for disposal.

Wear finger cots or gloves whenever handling or assembling a touch panel its glass edges are sharp.

12.2 REVISION

REV No.	ITEM	LOT No.	PRODUCTION CONTROL No.
A		-	00001~

12.3 LOCATION OF LOT MARK

(1) Lot mark is printed on back side of LCM (Fig.1).

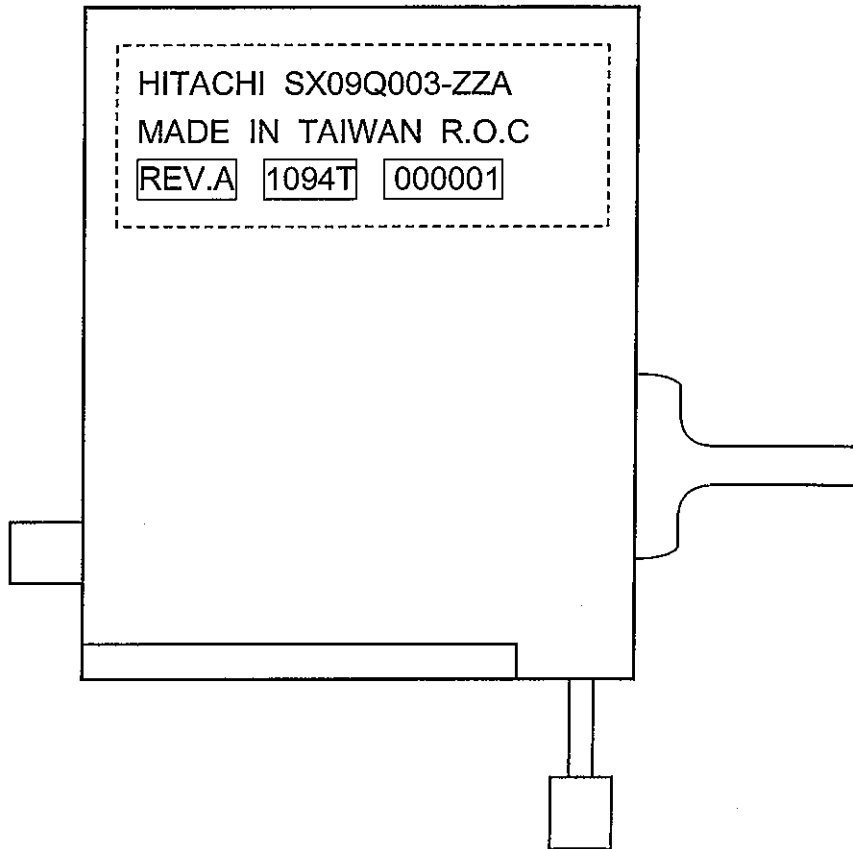

13. PRECAUTION FOR USE

(1) A limit sample should be provided by the both parties on an occasion when the both parties agree to its necessity.

Judgement by a limit sample shall take effect after the limit sample has been established and confirmed by the both parties.

(2) On the following occasions, the handling of the problem should be decided through discussion and agreement between responsible persons of the both parties.

(1) When a question is arisen in the specifications.

(2) When a new problem is arisen which is not specified in this specifications.

(3) When an inspection specifications change or operating condition change by customer is reported to HITACHI, and some problem is arisen in the specification due to the change.

(4) When a new problem is arisen at the customer's operating set for sample evaluation.

(3) Regarding the treatment for maintenance and repairing, both parties will discuss it in six month later after latest delivery of this product.

The precaution that should be observed when handling LCM have been explained above.

If any points are unclear or if you have any requests, please contact with HITACHI.