



INVERTER THYRISTOR C770 & C770A

77mm / 1800V / 60-80us

Disc-type ceramic PRESSPAK package

Type C770 reverse blocking thyristor is suitable for inverter applications. The silicon junction is manufactured by the proven multi-diffusion process and utilizes the exclusive involute gate structure. It is supplied in an industry accepted disc-type package, ready to mount using commercially available heat dissipators and mechanical clamping hardware.

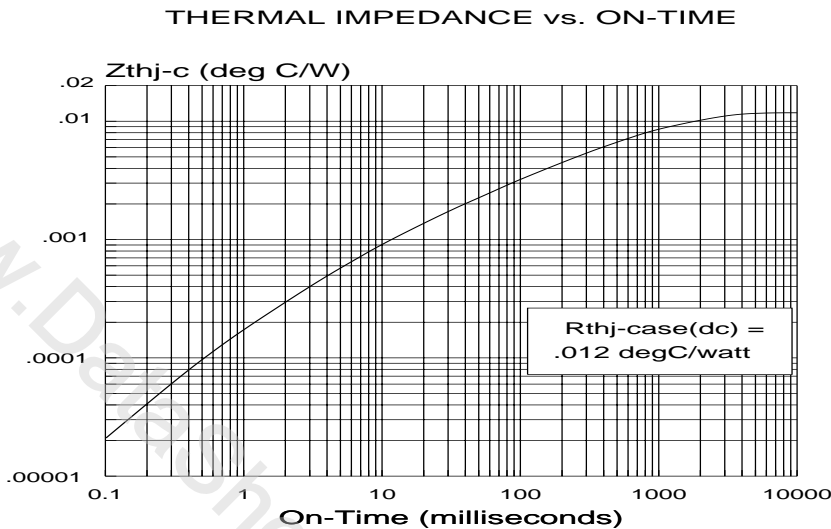
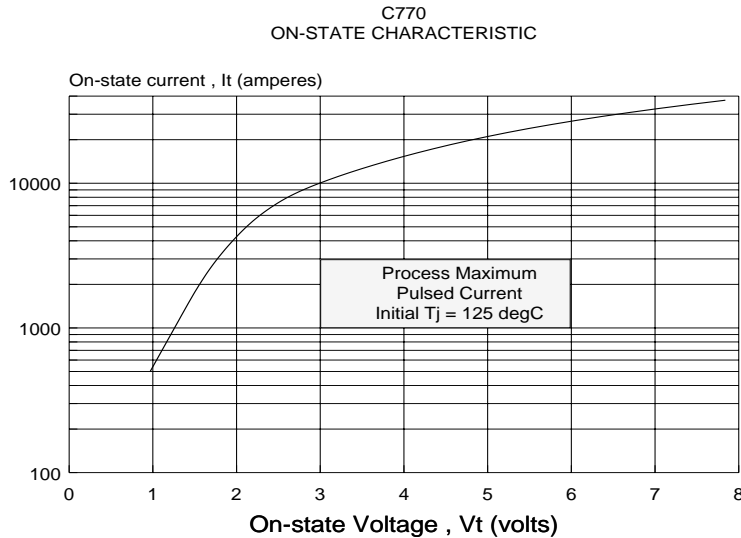

Blocking Voltage Code

C770__	C770A__
MODEL	V_{DRM}/V_{RRM}
	-40 to +125 °C

C770 <u>PN</u>	1800 Volts
C770 <u>PS</u>	1700
C770 <u>PM</u>	1600
C770 <u>PE</u>	1500
C770 <u>PD</u>	1400

Gate Drive Requirements:

open circuit voltage	30-40 V
internal impedance	10 Ω
rise time of s.s. current	0.5 - 1 μs
minimum duration	10 μs

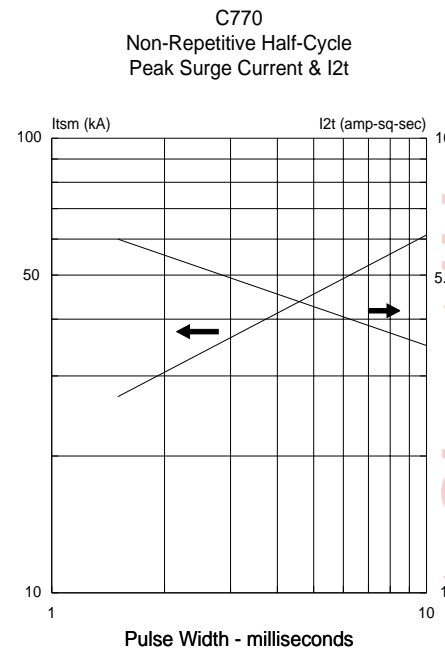

SILICON POWER CORPORATION
175 GREAT VALLEY PARKWAY, MALVERN, PA 19355
USA

LIMITING CHARACTERISTICS C770

PARAMETER	SYMBOL	TEST CONDITIONS	LIMIT	UNITS
Rep. peak rev. & off-state volts	V_{RRM} V_{DRM}	$T_j = -40$ to $+125^\circ\text{C}$	up to 1800	V
Reverse & off-state current	I_{RRM} I_{DRM}	$T_j = 125^\circ\text{C}$	100	ma
Average on-state current	$I_{T(AV)}$	$T_{CASE} = 70^\circ\text{C}$	2100	A
Non-rep. half cycle surge current	I_{TSM}	60 Hz (8.3ms) 50 Hz (10 ms)	38 35	kA
On-state voltage	V_{TM}	$I_T = 2000\text{A}$ <i>special C770A</i> $T_{CASE} = 125^\circ\text{C}$	1.55 1.60	V
Critical rate of rise of on-state current	$di/dt_{(rep)}$	$T_j=125^\circ\text{C}$ 60Hz	300	A/us
Critical rate of rise of off-state voltage	dv/dt linear	$T_j=125^\circ\text{C}$ 60Hz $V_{DCRIT}=67\%V_{DRM}$	500	V/us
Recovery current	I_{RM}	$T_j=125^\circ\text{C}$ @ 25 A/us	200	A
Turn-on delay	t_d	$V_D=67\%V_{DRM}$	2	us
Thermal resistance	R_{thJ-C}		.012	$^\circ\text{C/watt}$

C770 only

ENERGY LOSS PULSE / C770 THYRISTOR Half sine pulses / No reverse loss

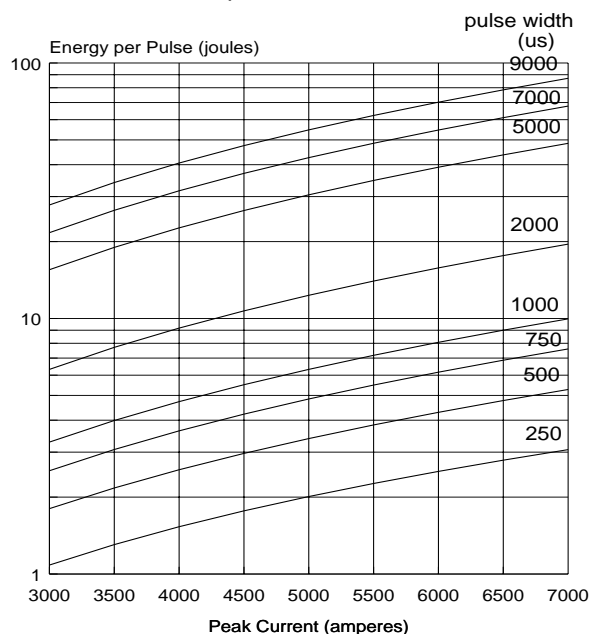

SIGC770A/89C

SELECTED RECOVERY TESTS

Turn-off Time

@ $T_j = 125^\circ\text{C}$

- LEM Thyristometre Type C770

conditions for $T_q \leq 80\text{us}$

$di_R/dt = 25 \text{ A/us}$

$V_R = -5\text{V}$

400V/us to $67\%V_{DRM}$

- Naturally Commutating Circuit

type C770A only

conditions for $T_q \leq 60\text{us}$

$I_t = 3000 \text{ A}$

$di_R/dt = 60 \text{ A/us}$

80 - 100V/us initial

$V_d = 1000\text{V}$

- Naturally Commutating Circuit

type C770A only

conditions : $di_R/dt = 60 \text{ A/us}$

$V_{R-appl'd} = 350\text{V}$

snubber $R=60\Omega$ $C=1\mu\text{F}$

$I_{RM} \leq 400\text{A}$ $Q_{RR} \leq 2000\mu\text{C}$

$S = t_b/t_a \geq 0.33$

C770 only

ENERGY PER PULSE Trapezoidal Wave - no reverse voltage $di/dt = 100 \text{ A/us}$

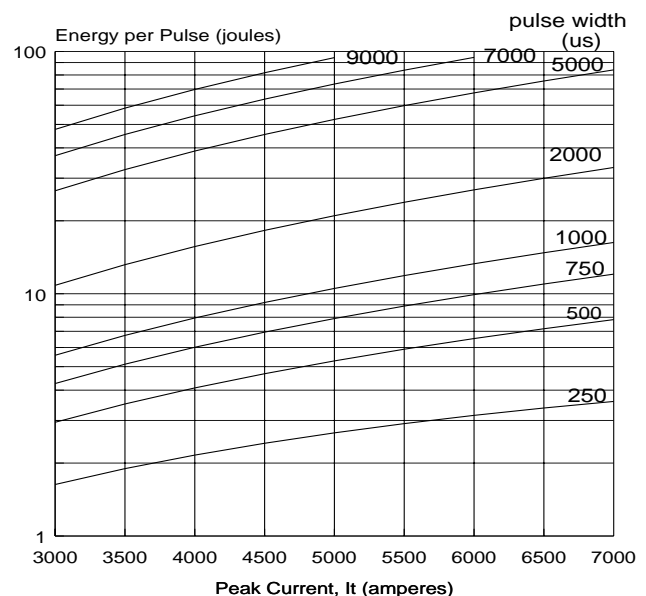

C770TR1/91a 2/7/91

MOUNTING PRESSPAKS TO HEAT DISSIPATORS

The following instruction is essential for maintaining low, stable thermal and electrical resistances associated with the PRESSPAK to heat dissipator surfaces.

1. INSPECTION OF MATING SURFACES

Check each mating surface for nicks, scratches and surface finish. The PRESSPAK surface has a total indicator reading TIR < .0005 inch and surface finish 32 prior to factory electrical test in pressure fixtures. The dissipator surface should be equally as good. The TIR of a fully tested PRESSPAK may run higher but not exceed 0.001 inch (***) not including some minor nicks and scratches associated with the test fixtures. Any bow created by clamp system at assembly must keep flatness within 0.001 inch. (***)

2. SURFACE DEOXIDATION AND CLEANING

Although plated surfaces are recommended for aluminum and copper heat dissipators, bare surfaces may be used if careful attention to cleaning and treating is assured. Plated surfaces and PRESSPAKS should be lightly sanded with 600 grit paper, then oil or compound applied as recommended. Unplated aluminum surfaces should be vigorously abraded with a fine wire brush or 3M "Scotchbrite" coated with Alcoa EJC #2 compound. The EJC #2 should be removed and the recommended compound applied.

3. FINAL SURFACE TREATMENT

Apply silicone oil or a very thin layer of grease or compound as indicated below. Rotate the PRESSPAK to properly distribute the applied agent.

- . bare copper - use G322L or LS2037
- . bare aluminum - use EJC #2 or G322L
- . tin plated copper or aluminum
 - preferably reapply DC550 or SF1154
 - alternatively use G623 or G322L
- . nickel plated aluminum - use DC550, G623 or G322L
- . silver plating - not recommended

Recommended silicone oils are SF1154 or DC550 (200 centistoke)

4. MOUNTING

Assemble with specified mounting force applied through a self-leveling swivel connection. The diameter of the swivel should be preferably equal but not smaller than the poleface diameter of the PRESSPAK. Center holes on the top and bottom of the PRESSPAK are for locating and positioning it to identical holes anticipated at the heat dissipator surfaces using 1/8" dia 3/16" roll pins.

NOTES:

Silicone oil DC550 (200 centistoke) is a product of DOW CORNING; clear silicone grease G623, yellow G322L and SF1154 (200 centistoke) GE Silicones Waterford NY; EJC# 2 from ALCOA and black LS2037 from ARCO, 7301 Bessemer Ave. Cleveland OH.

Limit maximum joint temperature to:

- 95 C using EJC #2
- 150 C using SF1154, DC550 or G322L

5. APPLIED MOUNTING FORCE

The selection of an appropriate commercially available spring clamping hardware* should consider establishing and maintaining the specified mounting force over the operating temperature range and operating life of the PRESSPAK. Thus essential ratings such as thermal resistance, $\Delta T/\Delta t$, surge current and thermal cycling will not be impaired.

Specified forces for this product are as follows:

7000-9000 lbs.
31.1 -40.0 kN

* Consult factory for recommendations or more detailed instructions.

MECHANICAL OUTLINE

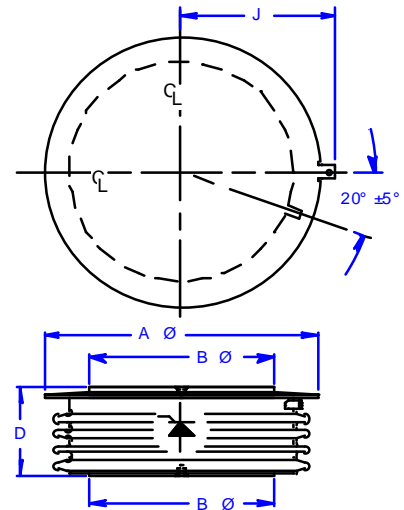

$A\Phi = 4.35 \text{ in (110.5 mm)}$

$B\Phi = 2.88 \text{ in (73.2 mm)}$

$D = 1.45 \text{ in (36.8 mm)}$

External Clamping Force

8000 - 9000 lbs.

35.6 - 40 kN