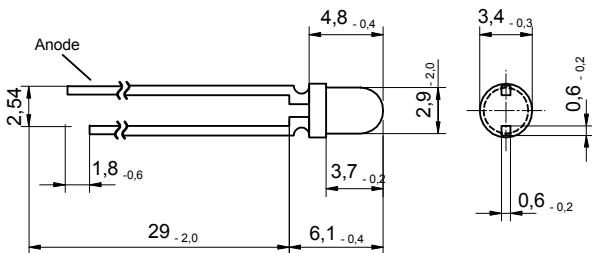

Radiation	Type	Technology	Case
Amber	Standard	AllnGaP/GaAs	3 mm plastic lens

	Description
	<p>Amber LED in standard 3 mm housing, small package allows compact design, housing without standoff leads</p> <p>Note: Special packages with standoff available on request</p>
	Applications
	<p>Illumination, safety equipment, automation, optical sensors</p>

### Maximum Ratings

$T_{amb} = 25^{\circ}\text{C}$ , unless otherwise specified

Parameter	Test conditions	Symbol	Value	Unit
Forward current (DC)		$I_F$	30	mA
Peak forward current	$(t_p \leq 50 \mu\text{s}, t_p/T = 1/2)$	$I_{FM}$	300	mA
Power dissipation		$P_D$	120	mW
Operating temperature range		$T_{amb}$	-20 to +85	$^{\circ}\text{C}$
Storage temperature range		$T_{stg}$	-30 to +100	$^{\circ}\text{C}$
Junction temperature		$T_J$	100	$^{\circ}\text{C}$

### Optical and Electrical Characteristics

$T_{amb} = 25^{\circ}\text{C}$ , unless otherwise specified

Parameter	Test conditions	Symbol	Min	Typ	Max	Unit
Forward voltage	$I_F = 20 \text{ mA}$	$V_F$		2.0	2.4	V
Reverse voltage	$I_R = 10 \mu\text{A}$	$V_F$	5			V
Radiant power*	$I_F = 20 \text{ mA}$	$\Phi_e$	1.3	1.8		mW
Luminous intensity*	$I_F = 20 \text{ mA}$	$I_v$	600	850		mcd
Peak wavelength	$I_F = 20 \text{ mA}$	$\lambda_p$	620	625	630	nm
Dominant wavelength	$I_F = 20 \text{ mA}$	$\lambda_D$		616		nm
Spectral bandwidth at 50%	$I_F = 20 \text{ mA}$	$\Delta\lambda_{0.5}$		18		nm
Viewing angle	$I_F = 20 \text{ mA}$	$\varphi$		20		deg.
Switching time	$I_F = 20 \text{ mA}$	$t_r, t_f$		80		ns

\*measured after 30s current flow

Note: All measurements carried out on *EPIGAP* equipment

We reserve the right to make changes to improve technical design and may do so without further notice.  
Parameters can vary in different applications. All operating parameters must be validated for each customer application by the customer.