

PLEASE CHECK WWW.MOLEX.COM FOR LATEST PART INFORMATION

Part Number: [0190770001](#)
Status: **Active**
Description: Avikrimp™ Star Ring Tongue Terminal for 18-22 AWG Wire, Stud Size 6

Documents:

[Drawing \(PDF\)](#) [RoHS Certificate of Compliance \(PDF\)](#)

Agency Certification

CSA LR18689
 UL E32244

General

Product Family Ring and Spade Terminals
 Series [19077](#)
 Crimp Quality Equipment Yes
 Mil-Spec N/A
 Product Name Avikrimp™
 Type Ring

Physical

Barrel Type Closed
 Flammability 94V-0
 Insulation Nylon (PA)
 Material - Plating Mating Tin
 Packaging Type Bag
 Plating min: Mating (µin) 100
 Plating min: Mating (µm) 2.5
 Plating min: Termination (µin) 100
 Plating min: Termination (µm) 2.5
 Stud Size 6 (M3.5)
 Termination Interface: Style Crimp or Compression
 Wire Insulation Diameter 3.51mm (.138") max.
 Wire Size AWG 18, 20, 22
 Wire Size mm² 0.25 - 1.30

Material Info

Old Part Number SRA-829-06

Reference - Drawing Numbers

Sales Drawing SD-19077-001

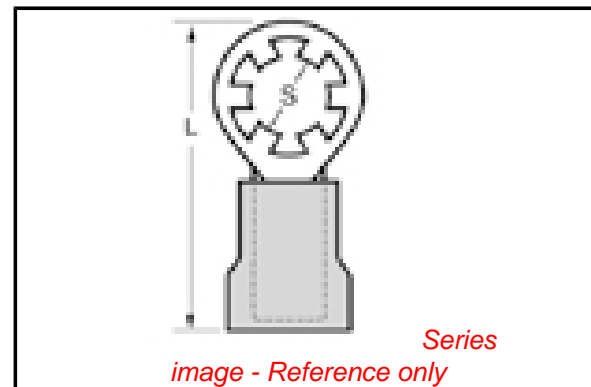

EU RoHS

ELV and RoHS Compliant
REACH SVHC
 Not Reviewed
Halogen-Free Status
Not Reviewed

China RoHS



Need more information on product environmental compliance?

Email productcompliance@molex.com
 For a multiple part number RoHS Certificate of Compliance, [click here](#)

Please visit the [Contact Us](#) section for any non-product compliance questions.

Search Parts in this Series

[19077Series](#)

Application Tooling | [FAQ](#)

Tooling specifications and manuals are found by selecting the products below. Crimp Height Specifications are then contained in the Application Tooling Specification document.

Global

Description	Product #
Hand Crimp Tool	0640010500
Crimp Head for the AT-200™ Pneumatic Hand Tool	0640050500

MATERIAL NO.	ENG. NO.	MATERIAL NUMBER TAPE MOUNTED	ENG. NO. TAPE MOUNTED	STUD SIZE	"S" ±.005/.127	"K" REF DIA	WIRE RANGE AWG / MM ²	INSULATION COLOR	I.D. MIN	MWID
190770001	SRA-829-06	190770002	SRA-829-06T	6	.146 (3.71)	.236 (5.99)	22-18/.25-1.3	RED	.062/1.57	.138/3.51
190770005	SRA-829-08	190770006	SRA-829-08T	8	.173 (4.39)	.263 (6.68)				
190770007	SRA-829-10	190770008	SRA-829-10T	10	.198 (5.03)	.288 (7.32)				
190770015	SRB-829-06	190770016	SRB-829-06T	6	.146 (3.71)	.236 (5.99)	16-14/1.0-2.6	BLUE	.086/2.18	.169/4.29
190770017	SRB-829-08	190770018	SRB-829-08T	8	.173 (4.39)	.263 (6.68)				
190770019	SRB-829-10	190770020	SRB-829-10T	10	.198 (5.03)	.288 (7.32)				

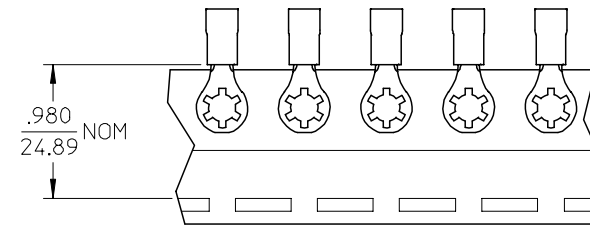
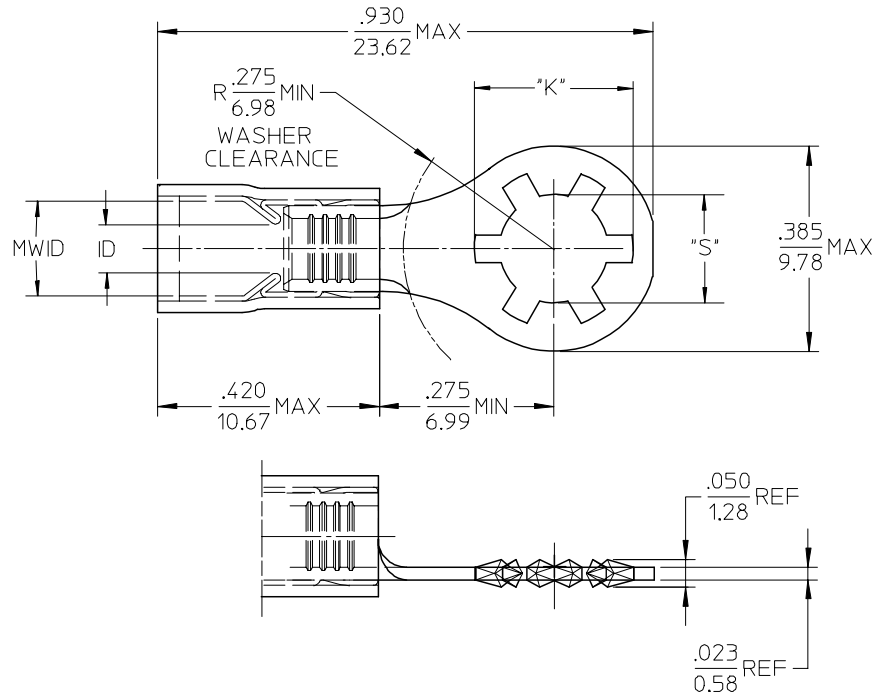

SALES DRAWING

NOTES:

- MATERIAL: BRASS.
PLATING: ELECTROPLATE TIN.
- FERRULE: BRASS ELECTROPLATE TIN.
PLATING: ELECTROPLATE TIN.
- INSULATION: NYLON.
- MWID=MAXIMUM WIRE INSULATION DIA.
- ALL DIMENSIONS IN INCHES (MM).

EC NO: ETC2004-0126 DRWN:DMYRICK 2004/01/06 CHKD:SBEITZEL 2004/01/06 APPR:RDEROSS 2004/01/07	QUALITY SYMBOLS ▽ = 0 ▽ = 0	GENERAL TOLERANCES (UNLESS SPECIFIED)		SCALE NTS	DESIGN UNITS INCH	THIRD ANGLE PROJECTION	REVISE ON CAD ONLY		
			mm	INCH	DIMENSION STYLE IN/MM		TITLE		
		4 PLACES	± ---	± ---	DRAWN BY DMYRICK	DATE 03/12/22	AVIKRIMP STAR RING TONGUE TERMINALS		
		3 PLACES	± ---	± .005	CHECKED BY SBEITZEL	DATE 03/12/22	MOLEX INCORPORATED		
	2 PLACES	± 0.13	± .01	APPROVED BY RDEROSS	DATE 03/12/22	MATERIAL NO. SEE CHART	DOCUMENT NO. SD-19077-001	SHEET NO. 1 OF 1	
	1 PLACE	± 0.25	± ---	DRAFT WHERE APPLICABLE				THIS DRAWING CONTAINS INFORMATION THAT IS PROPRIETARY TO MOLEX INCORPORATED AND SHOULD NOT BE USED WITHOUT WRITTEN PERMISSION	
	ANGULAR ±1/2°		MUST REMAIN WITHIN DIMENSIONS						