

THIS DRAWING IS UNPUBLISHED. RELEASED FOR PUBLICATION 20
 © COPYRIGHT 20 BY TYCO ELECTRONICS CORPORATION. ALL RIGHTS RESERVED.

LOC	DIST	REVISIONS			
P	LTR	DESCRIPTION	DATE	DWN	APVD
	C2	REVISED PER ECO-08-003323	06FEB2008	SS	MS

- CONDUCTOR
 NOMINAL STRANDING: 104/0100
 NOMINAL DIAMETER: .120
- JACKET CONSTRUCTION
 OUTSIDE DIAMETER: .215±.005
 COLOR: BLACK
- MARKING
 TE ELECTRONICS 10 AWG (5.26mm²) XHHW-2 OR
 XHH OR RHW-2 OR RHH SR OR USE-2 SUNLIGHT
 RESISTANT (UL) 600V VWI UL LISTED.
- △ PART COMES IN 30" DRUM.
- ALL MATERIALS AND FINISHES SHALL COMPLY WITH EU DIRECTIVE
 2002/95/EC OF 27JAN2003 (ROHS).

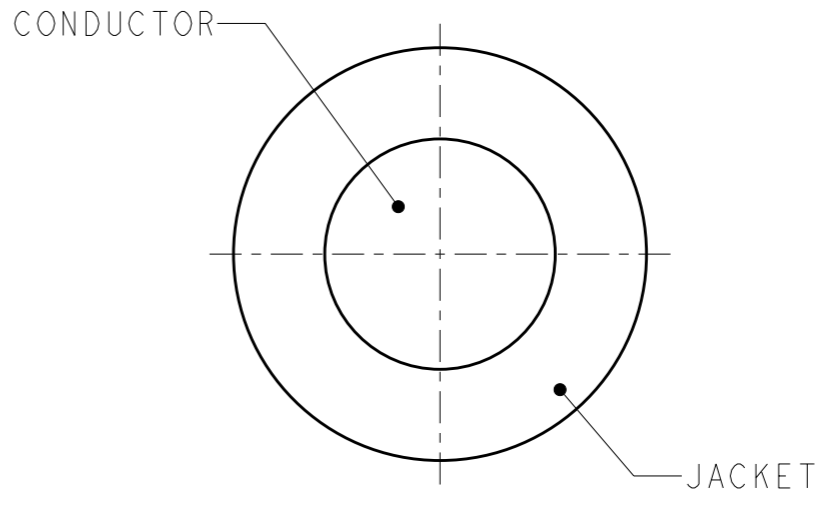

1000 FT REEL	1986164-3
500 FT REEL	1986164-2
△ 5000 FT REEL	1986164-1
CABLE LENGTH	PART NUMBER

www.DataSheet4U.com

<small>THIS DRAWING IS A CONTROLLED DOCUMENT FOR TYCO ELECTRONICS CORPORATION IT IS SUBJECT TO CHANGE AND THE CONTROLLING ENGINEERING ORGANIZATION SHOULD BE CONTACTED FOR THE LATEST REVISION.</small>		DWN S. WELDON 03APR2007 CHK M. STRECKEWALD 03APR2007 APVD M. STRECKEWALD 03APR2007		Tyco Electronics Harrisburg, PA 17105-3608	
DIMENSIONS: INCHES 		TOLERANCES UNLESS OTHERWISE SPECIFIED: 0 PLC ±. 1 PLC ±.1 2 PLC ±.02 3 PLC ±.005 4 PLC ±.0005 ANGLES ±.		NAME SOLAR CABLE, UL-LISTED, 10 AWG PRODUCT SPEC - APPLICATION SPEC - WEIGHT -	
MATERIAL - FINISH -		CUSTOMER DRAWING		SIZE A3 CAGE CODE 00779 DRAWING NO C-1986164 RESTRICTED TO -	
SCALE 10:1				SHEET OF REV www.DataSheet4U.com	