

Microcontrollers

ApNote

AP1632

additional file
AP163201.EXE available

Using the SSC (SPI) Interface in a Multimaster System

In the SAB C165 and C167, an internal High-Speed Synchronous Serial Interface is implemented providing serial communication between C167 / C165 or other microcontrollers with a transfer rate up to 5 Mbaud.

The demo software is a multimaster full-duplex system in which at a given time one microcontroller is configured as master while all others are in slave mode.

Andreas Hettmann / Siemens Cupertino

1	Introduction	3
2	General operation and hardware environment for the SSC demo.....	3
3	SSC demo software description	5
3.1	Main program.....	5
3.2	System initialization	5
3.3	SSC initialization.....	6
3.4	Key service routine	7
3.5	Routines for SSC data transmission.....	8
3.5.1	Send data	9
3.5.2	Receive data.....	10
3.6	Running LED light.....	11
3.7	SSC scan routine.....	12
3.8	Creating the microcontroller executable files.....	12
3.9	Know problems	14
4	Source codes and compiling tools	15
4.1	SSC demo software: C code	15
4.1.1	Main program - SSC.C.....	15
4.1.2	System initialization - INIT_SYS.C	16
4.1.3	SSC initialization - INIT_SSC.C18	
4.1.4	Key interrupt service routine - KEY_INT.C	19
4.1.5	Running LED light - RUNLIGHT.C	22
4.1.6	SSC scan routine - SSC_SCAN.C	23
4.1.7	SSC receive interrupt service routine - RX_INT.C.....	24
4.1.8	SSC transmit routine - TX_SSC.C	26
4.1.9	SSC transmit interrupt service routine - TX_INT.C.....	27
4.1.10	C header file - SSC.H	28
4.2	System register initialization, ASM code - INIT_167.SRC.....	29
4.3	Linker and locator control file - SSC.ILO	32
4.4	Locator output file - SSC.MAP.....	33
4.5	Miscellaneous files for compiling	35
5	LED display board - schematic.....	40

AP1632 ApNote - Revision History		
Actual Revision : Rel.01		Previous Revision: none
Page of actual Rel.	Page of prev. Rel.	Subjects changes since last release)

1 Introduction

In the SAB C165 and C167, an internal High-Speed Synchronous Serial Interface is implemented providing serial communication between C167 / C165 or other microcontrollers with a transfer rate up to 5 Mbaud at 20 MHz CPU clock. Due to the very flexible configuration options this interface can be used in a wide range of applications from simple external shift registers to expand the number of parallel ports or primitive pulse width modulation (PWM) to high-end protocol driven microcontroller networks. For a complete list of options for configuring the SSC refer to the C165 or C167 User's Manual, edition 8/94, section 11. Shown in the demo software is a multimaster full-duplex system in which at a given time one microcontroller is configured as master while all others are in slave mode.

This demo software has been created to show an example how to use the High-Speed Synchronous Interface in a non-trivial application and to support solving of user specific demands concerning the SSC. Due to pin limitations at Port2 (only P2.0-P2.7 available) of the C165 it is recommended to use this software with C167 based boards only.

2 General operation and hardware environment for the SSC demo

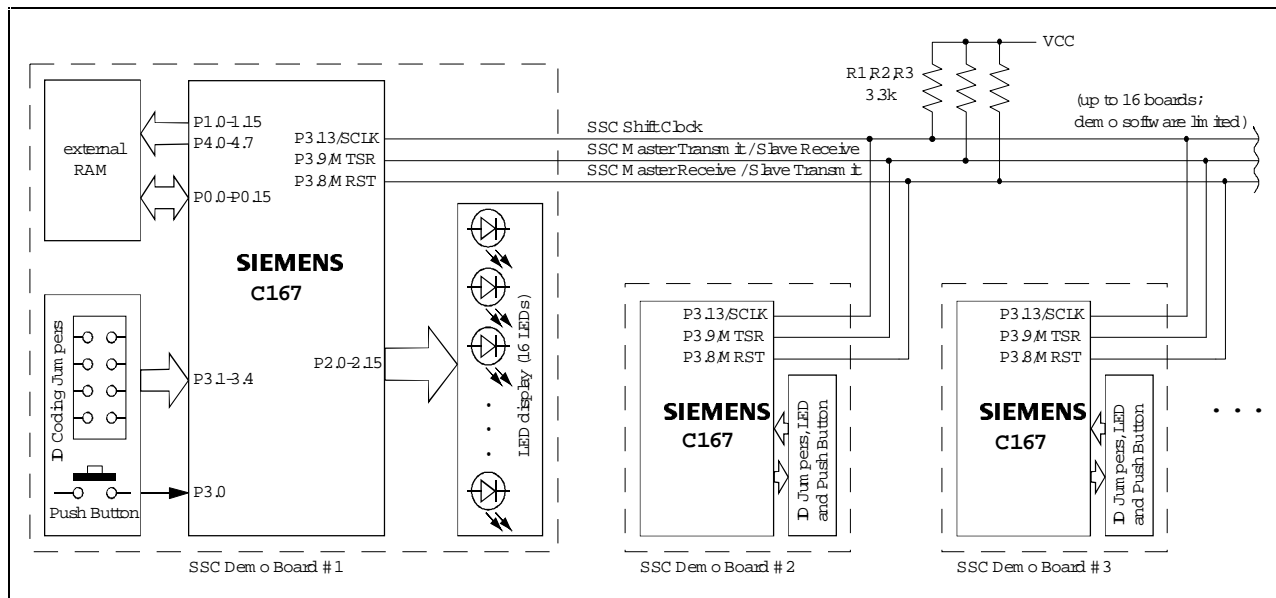

Figure 1:
Hardware for the SSC demonstration software

As shown in fig. 1, up to 16 C167 based boards are connected in full-duplex operation via the SSC lines SCLK (SSC Shift Clock), MTSR (Master Transmit Slave Receive) and MRST (Master Receive Slave Transmit). Every board is identified by a combination of 4 jumpers on the LED display board providing a 4-bit board ID. These ID is used in creating and decoding messages to specify source and destination board. After starting the program, the current board ID value is displayed on the center part of the LED display.

Following the SSC and the board are configured to slave indicated by a running LED light. Pushing the button on the display board now forces the controller to create a message to be sent via the SSC requiring master status for the board when the current master is providing SSC Shift Clock. If there is no master in the system (e.g. after start-up of all boards) the controller waits for a certain time and automatically becomes master when no clock is applied. The LED display now shows in the center part the (binary) number to be added to the board ID resulting in the board ID of the remote controlled board. Remote controlled boards remaining in slave mode are accessed in ascending order by additional single clicks providing a wrap-around. Double-clicking the masters button will now result in toggling the direction of the running LEDs on the remote controlled board. Additionally, there is a 16 word data transfer performed between specified memory areas of master and slave which can only be detected using monitor software to view the memory or recording the SSC data flow using a digitizing scope in single-shot mode. A brief graphical overview of the activities is shown in the chart in fig.2

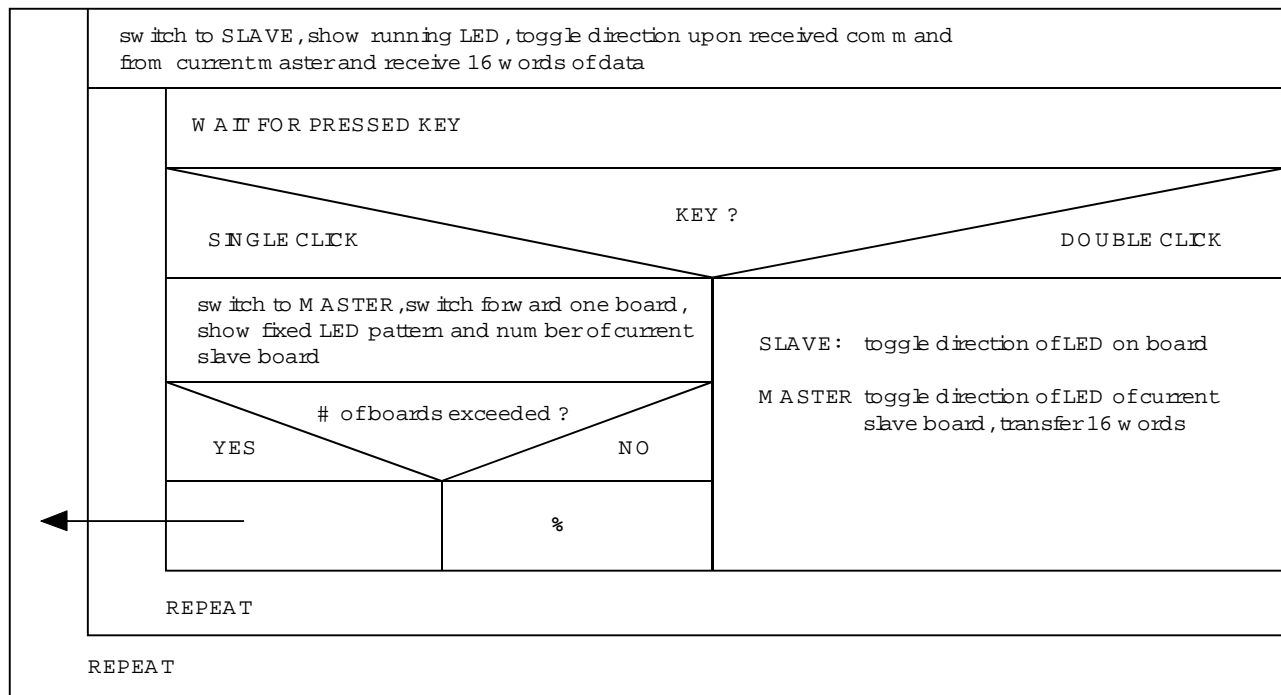

Figure 2:
Flow of software from the user's view

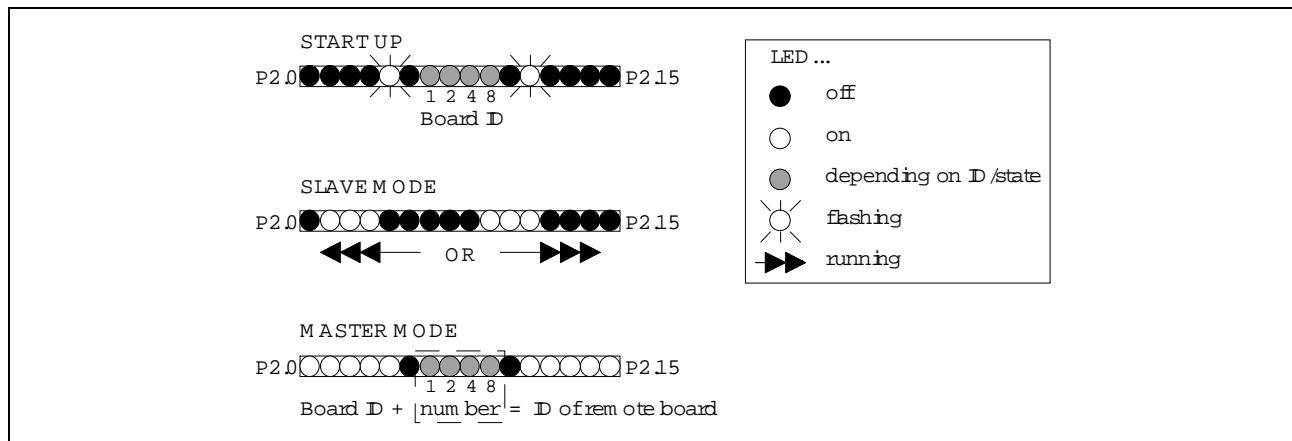

Figure 3:
Functions of the LED display in different operating modes

3 SSC demo software

The software is divided into several modules each performing very specific actions described in the following sections.

3.1 Main program

Because the software is event-controlled (interrupts), the main program consist only of a system initialization routine call and a loop containing the IDLE instruction. Each time IDLE is executed the CPU is powered down while all peripherals like timers remain running. This state is held until an interrupt occurs (e.g. from SSC scan, running LED). After executing the system initialization all used state variables and on-chip devices like timers, PEC and SSC are configured. See also chapter 3.2 and 4.1.1.

3.2 System initialization

The system initialization routine `INIT_SYS` is executed only once during start-up and performs initialization of global variables and loading of the configuration registers of the used on-chip peripherals. These devices are configured as following:

- Port2 to output for driving the LED display
- Timer2 to 50 ms, used in master mode to provide all slave boards periodically with SSC clock
- Timer5 to 50 ms, used in slave mode for the running LED pattern (one shift per timer overflow)
- Timer0 as counter for P3.0 to detect pushed key
- PEC0 to transfer one word from SSC receive buffer to receive data buffer in memory
- PEC2 to transfer 16 words from SSC receive buffer to auto-incremented receive data buffer location in memory
- SSC with fixed baudrate as defined in the C header file `SSC.H`
- SSC to slave move (see also chapter 3.3)

For the code listing of `INIT_SYS.C` see 4.1.2.

3.3 SSC initialization

Prior to initialization it is required to disable the SSC by clearing the configuration register SSCCON. Then the pins used by the SSC (MRST, MTSR and SCLK) have to be configured whether to output or to input depending on the desired mode of the SSC. In master mode, SCLK providing shift clock for all SSC and the master transmit pin MTSR are outputs while the master receive pin has to be set to input (Port3 direction register DP3). In slave mode, all three port pins are configured to input (SCLK receives shift clock from the current master, MTSR is the slave receive line and MRST is only switched to output when the slave transmits data to the master to avoid collisions on this line). In order to use these alternate functions of Port3, the bits of the output latch are to be set to '1' because it is ANDed with the alternate function.

In the demo software, the SSC is configured to a data width of 16 bit (SSCBM), transmit and receive MSB first (SSCHB), shift transmit data on the leading edge (SSCPH), idle clock line low (SSCPO) and ignoring all errors (SSCTEN,SSCREN,SSCPEN,SSCBEN), resulting in a initialization value of 0x805F in slave mode or 0xC05F in master mode (fig.3). Configuring and enabling the SSC is done by simply writing this value into SSCCON and takes only one instruction.

For the code listing of the SSC initialization file, INIT_SSC.C, see 4.1.3.

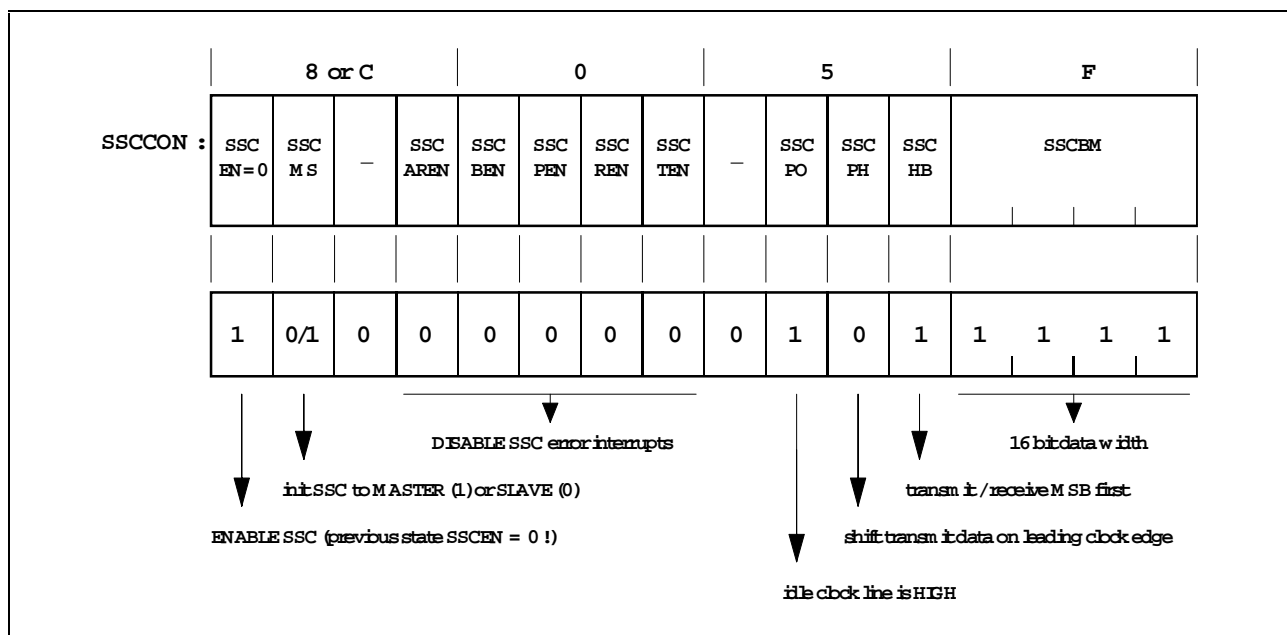

Figure 4:
Configuring the SSC in the demo software

3.4 Key service routine

The key service routine is a interrupt service routine called by an Timer0 overflow interrupt caused by pressing the key or a spike on this line. Spikes and bursts induced by the key contact material of less than about 2 ms are filtered out by the routine SCAN and do not cause an erroneous action of the software. As shown in the flowchart (fig. 4) below the first assumption about the pressed key is to be a single click which would cause the transmission of master request and become master or, if already master, switching the remote slave boards as explained in chapter 1. But, if the key is pressed again within a time frame of 300 ms after releasing, this is recognized as an double click and forces the software in master mode to send a command to the remote controlled slave board to toggle the direction of the running LEDs and in slave mode to toggle the direction of the on-board LED display.

For the code listing of the key interrupt service routine, KEY_INT.C, see 4.1.4.

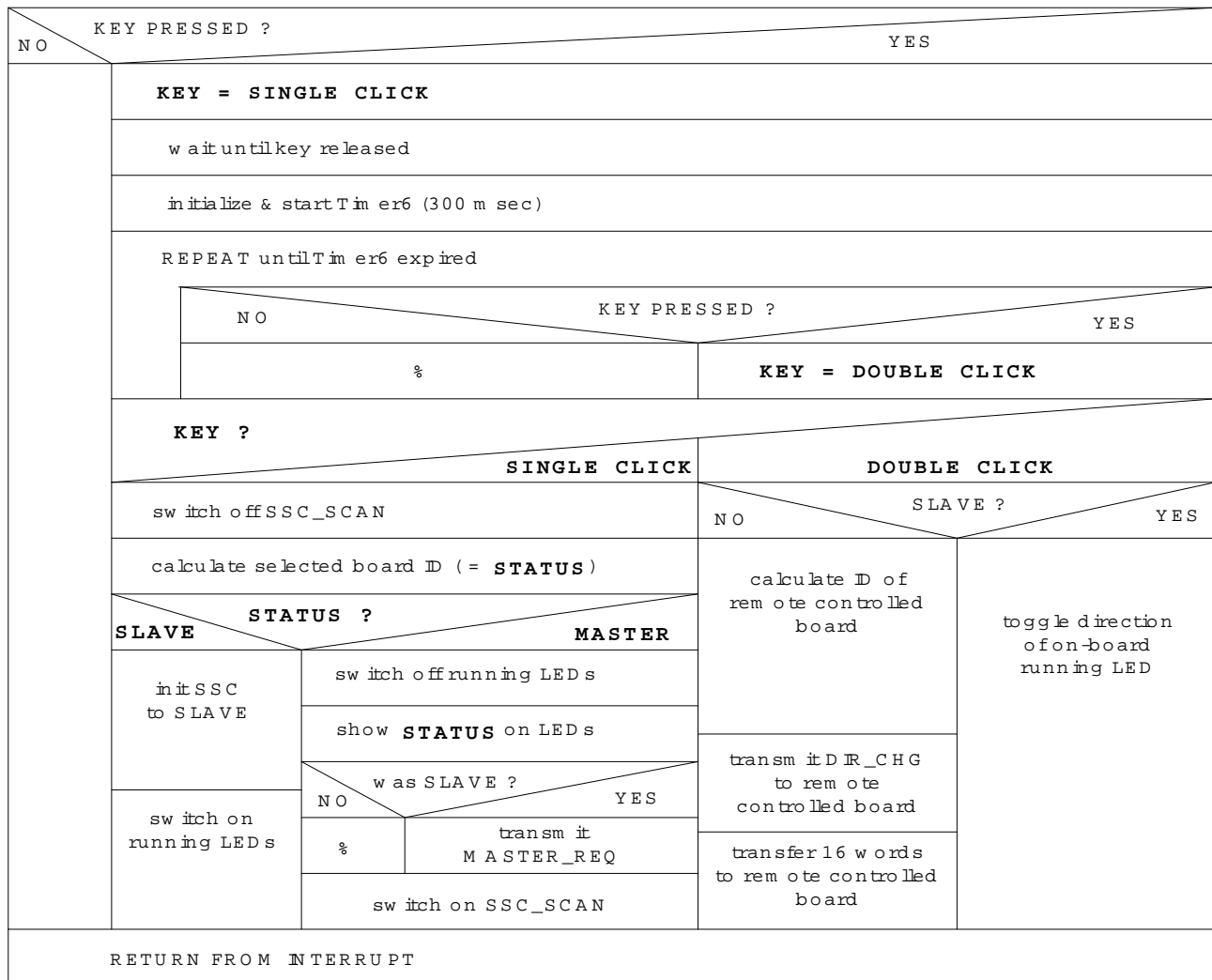

Figure 5:
Key Interrupt Service Routine

COMMAND NAME	HEX VALUE	DESCRIPTION
IDLE	000 (0h)	dummy command for SSC_SCAN, sent by master
DIR_CHG	101 (5h)	command 'toggle direction of running LEDs', sent by master to current remote controlled slave
MASTER_REQ	111 (7h)	request become master, sent by slave
OK	010 (2h)	acknowledge for MASTER_REQ, sent by master

Figure 6:
Agenda of protocol commands used in SSC communication

3.5 Routines for SSC data transmission

Since the serial SSC data is collected in a shift register transmitting and receiving is synchronized and performed at the same time. The pins MRST and MTSR are assigned to the input and the output of the shift register according to the operating mode (master or slave) so there is no need for external hardware to switch the pins in master or slave mode.

3.5.1 Send data

Transmitting data is performed by simply writing the data value into the SSC Transmit Buffer SSCTB. If the shift register is empty, that means, the last transmission is already finished, the contents of the SSCTB is copied immediately to the shift register. In master mode, transmission starts instantly by supplying SSC shift clock on SCLK and shifting out data on MSTR while in slave mode the data remains unchanged in the shift register until the remote master applies SSC shift clock. Data is then shifted out on MRST.

In all modes, after copying the data from SSCTB to the shift register, an SSC transmit interrupt indicates a request for new data to be transmitted. This is especially used for transferring 16 words after the command DIR_CHG when the SSC transmit interrupt causes PEC1 to transfer data from a memory array to SSCTB without any interrupt service routine.

For the C code of the routines TX_SSC.C and TX_INT.C see 4.1.8 and 4.1.9.

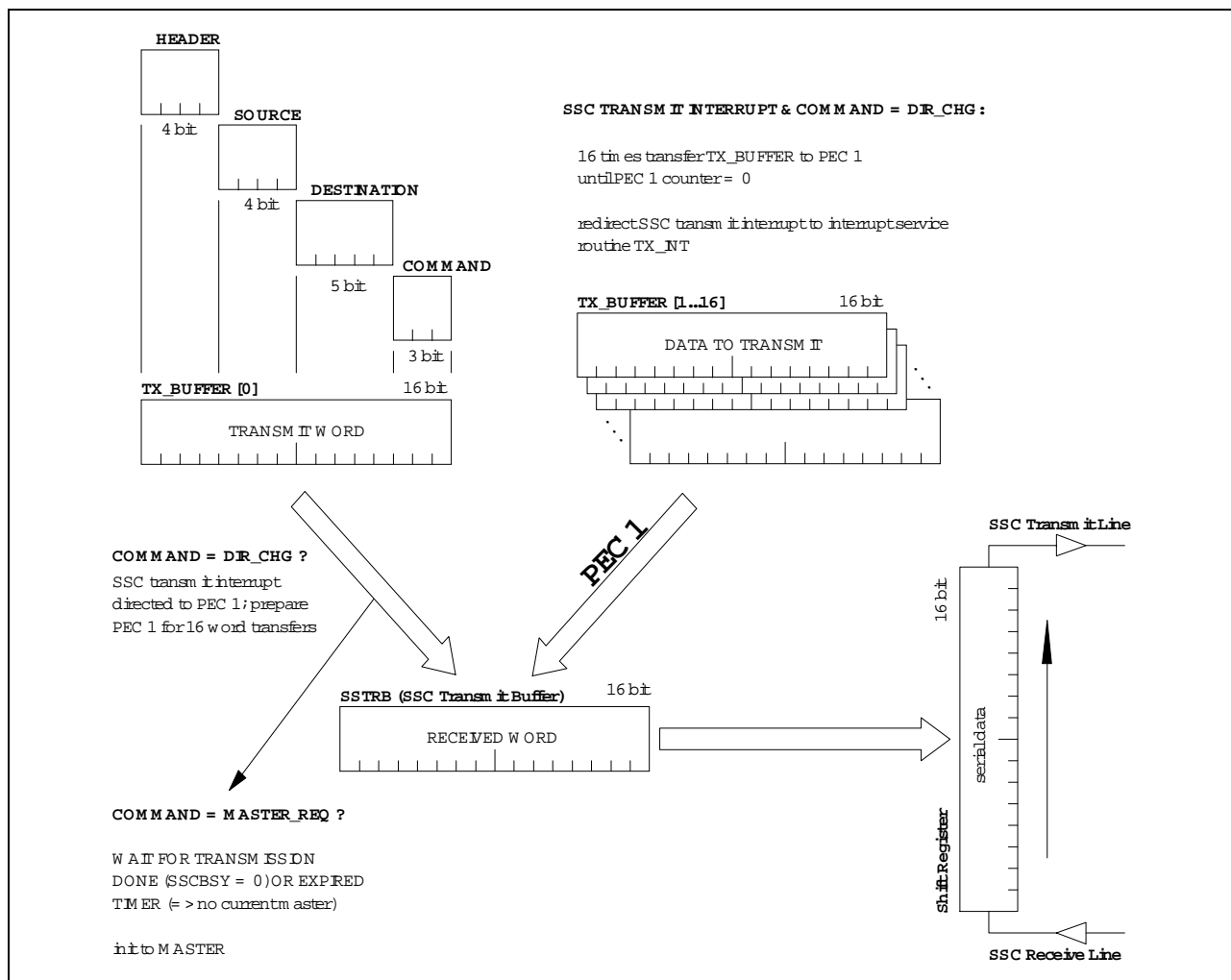

Figure 7:
Transmitting Data via SSC

3.5.2 Receive data

As mentioned, receiving of data via the SSC is always synchronized with transmitting data. If the selected number of bits is received data is automatically transferred from the shift register into the SSC receive buffer SSCR_B. The software is then notified by an SSC receive interrupt to copy the value of SSCR_B into any software buffer before the next SSC data word is received. In the demo software, initially the SSC receive interrupt is directed to PEC0 which transfers the received word into RX_BUFFER[0] and then calls the

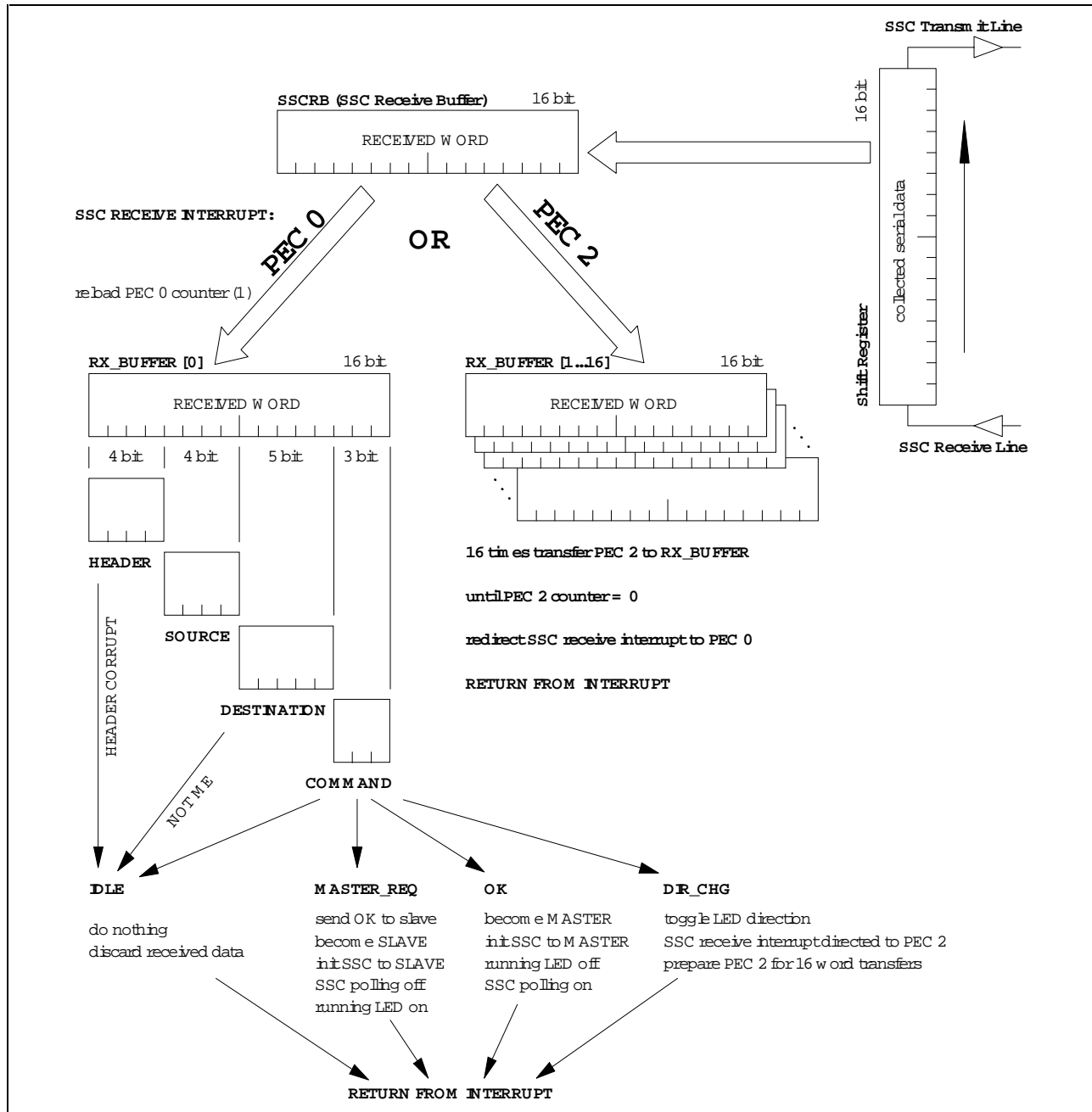

Figure 8:
Receiving Data via SSC

interrupt service routine `RX_INT` because `PEC0` counter has been decremented to 0. If the command `DIR_CHG` is decoded, the SSC receive interrupt is then directed to `PEC2` which will transfer 16 consecutive words from the `SSCRB` to the `RX_BUFFER`. After that, `RX_INT` is called again (`PEC2` counter = 0) and the SSC receive interrupt is redirected to `PEC0` to prepare receiving of the next word.

Depending on the received command, several actions will take place as shown in the diagram in Fig. 6.

For the code listing of `RX_INT` refer to chapter 4.1.7.

3.6 Running LED light

The running LED light is controlled by the interrupt service routine `RUNLIGHT` which is called each time after an `Timer5` overflow has occurred, that means, after the delay time for a LED left or right step is passed. The current LED status is obtained from a global variable, rotated to the right or to the left depending on the direction variable and written back to the global variable and to `Port2` where the LEDs are connected to. Because `Timer5` is not capable of self reload, the `Timer5` control and timer registers have to be reloaded to feature the appropriate delay time and restart of the timer. For a graphical description see fig. 7, the C code of the routine `RUNLIGHT.C` can be found in chapter 4.1.5.

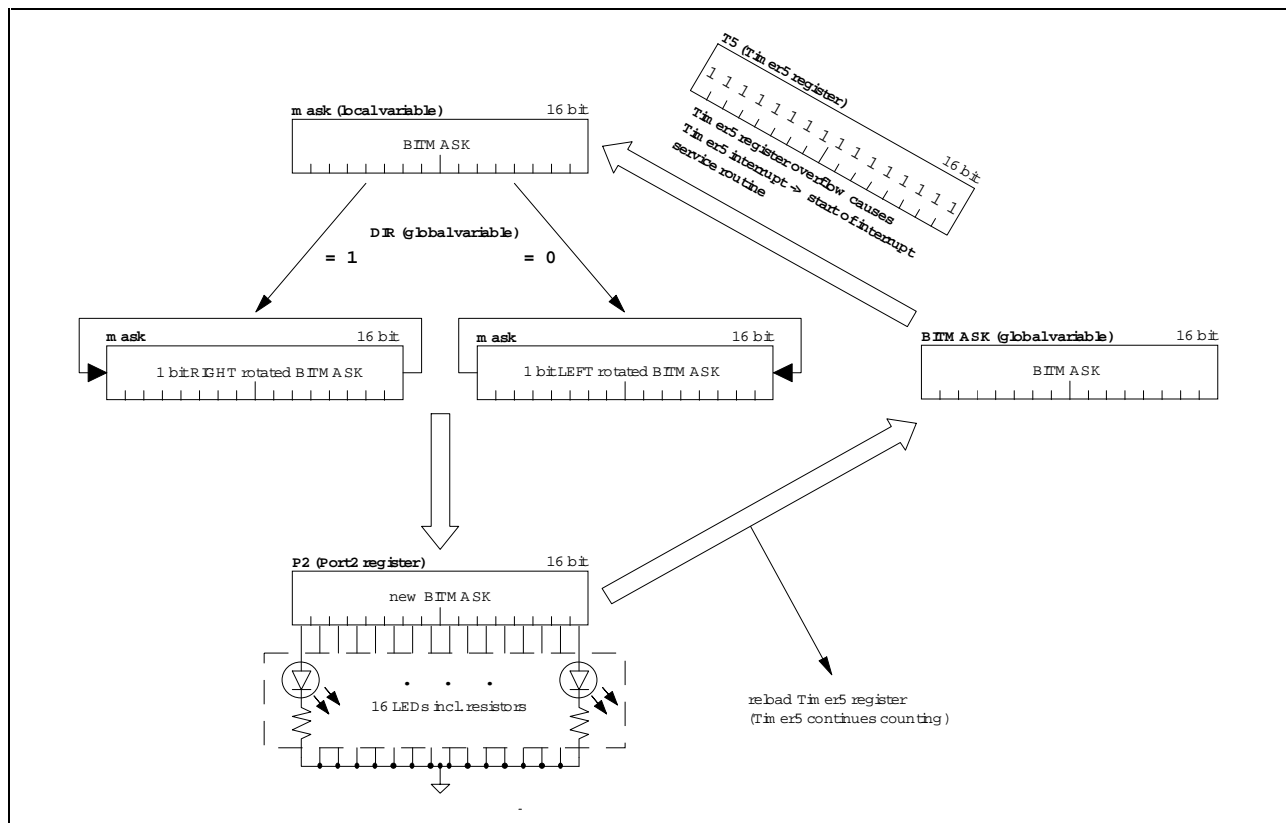

Figure 9:
Timer 5 interrupt service routine for running LED light

3.7 SSC scan routine

In master mode, the SSC scan routine is called by an expired Timer2 causing an interrupt and performs periodical transmitting of dummy words. This must be done because the transmitting master supplies all slaves with SSC shift clock in order to make transmitting of `MASTER_REQ` for the slave possible. After the master SSC starts transmitting, the Timer2 is reloaded and started to obtain constant scanning.

For the code listing of this routine, `SSC_SCAN.C`, see 4.1.6.

3.8 Creating the microcontroller executable files

For running the SSC demo, the C code files and the assembly startup file have to be compiled, linked, located and converted into a format the monitor software is capable to upload into the microcontroller. When using the BSO/Tasking C compiler and the Hitop debugger light (Hitex), a make file (`SSC.MAK`; starting the make process by executing `MAKE.BAT`) has been prepared to control compiling. The make file is executed from the bottom of the file upwards depending on the file dates (newer source files will be converted, unaltered source files with existing converted files remain untouched). For control of linking of the modules and creating the interrupt vector table the file `SSC.ILO` is used containing information of module related interrupt numbers, classes memory locations and reserved areas not to be used by the user. A graphical overview of the use of the compiling tools by the MAKE utility for obtaining microcontroller executable files is shown in fig. 10. Note that the paths and DOS environment variables for the compiling tools have to be set by calling `SETPATH.BAT` (see listing in 4.5).

Before loading the program code from `SSC.HTX` into the microcontroller memory, the controller has to be booted by executing `BOOT.BAT`, which causes `BTDL.EXE` to load the files `BOOT.BSL` (boot software, sets the system registers to required values depending on the hardware, e.g. memory waitstates, system stack size and prepares the controller to load the monitor) and `EVA167.HEX` (monitor software) into the microcontroller's memory to make communication between the PC based debugging software and the microcontroller possible. The monitor software has been slightly changed (not possible using the 'light' version) to ensure matching hardware values in boot file and monitor. Then the debugging software has to be started by executing `HIT1.BAT` (edit this file for different COM port or transfer speed configurations).

After loading (`SSC.HTX` and the symbol file `SSC.SYM`) and starting the SSC demo software by the Hitop debugger, it is recommended to leave the debugger because the extensive use of timers in the SSC software can interfere with the communication between PC and the debugger which results in the error message "Could not send command".

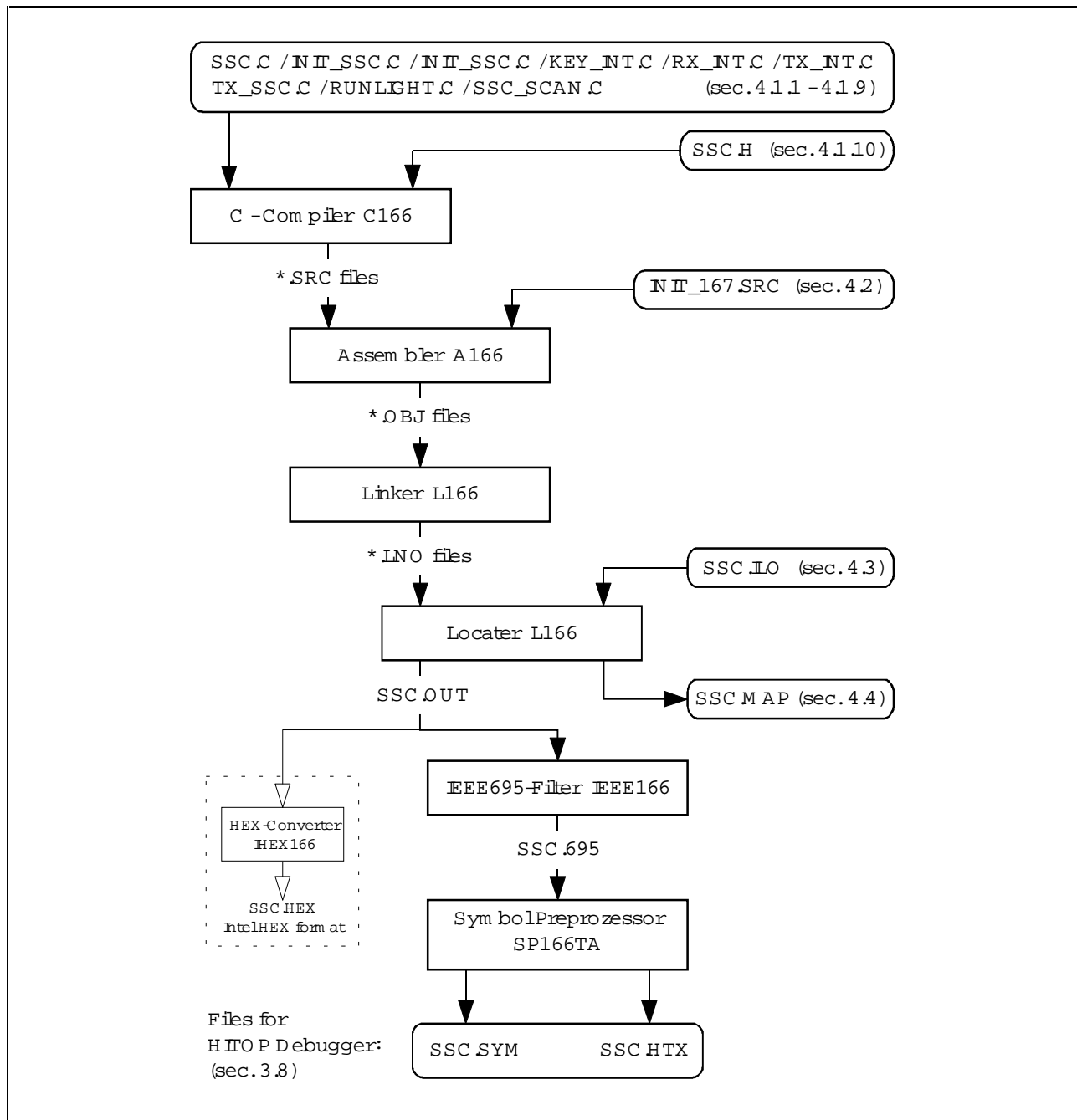

Figure 10:
Making C16x controller executable files

3.9 Known problems

The SSC normally operates at speeds up to 5 MBaud. Long signal lines and improper PCB design can cause the transmission to fail at higher baud rates because the output driver of the SSC lines meet only the standard requirements for TTL compatibility. During software development for the SSC demo the available C167 boards operated correctly only up to approximately 115 kBaud when connected together to a 3 or more board system. Only a system consisting of two C167 boards worked correctly up to the maximum transfer rate.

4 Source codes and compiling tools

4.1 SSC demo software: C code

4.1.1 Main program - ssc.c

```

/*****
*   program   : ssc.c                               *
*   name      : Andreas Hettmann   Siemens, Cupertino/CA *
*   date      : 5'96                               *
*   function  : SSC demo                             *
*****/

/* #pragma mod167 */

#include <reg167.h>          /* register definitions */
#include "ssc.h"            /* definitions          */

extern void INIT_SYS (void);          /* use external routines */

#pragma global             /* make next definitions useable for external C modules */
unsigned int STATUS;       /* word STATUS = actual status of board (slave, ... */
unsigned int BOARD_ID;    /* word BOARD_ID = board id as jumpered on P3.1-4 */
unsigned int BITMASK;    /* word BITMASK = running LED actual output state */
bit DIR;                 /* bit DIR = current direction of running LEDs */
bit KEY_IDLE;           /* bit KEY_IDLE = input level, key not pressed */
unsigned int RX_BUFFER [1 + TRANSFER_CNT], TX_BUFFER [1 + TRANSFER_CNT];
                        /* word array storing rec and transmit data */

interrupt (mainintno) void Int_MAIN (void);          /* main task interrupt# */
                                                    /* prototype definition */

#pragma public

interrupt (mainintno) void Int_MAIN()                /* main task */
{
  INIT_SYS ();          /* initialize all devices needed for the demo program */

  while ( 1 )          /* infinite loop, program is event controlled (interrupts) */
  {
    #pragma asm
    IDLE                ;enter CPU idle mode, return to normal operation by interrupt
    #pragma endasm
  }
}

```

4.1.2 System initialization - INIT_SYS.C

```

/*****
* program   : init_sys.c
* name      : Andreas Hettmann   Siemens, Cupertino/CA
* date      : 5'96
* function  : initializes system
*****/

#include <reg167.h>          /* register definitions */
#include "ssc.h"            /* int # definitions */

extern bit DIR;             /* global variables of bit type, defined in SSC.C */
extern bit KEY_IDLE;
extern unsigned int STATUS; /* global variables of word type, def. in SSC.C */
extern unsigned int BOARD_ID;
extern unsigned int BITMASK;
extern unsigned int RX_BUFFER [1 + TRANSFER_CNT]; /* (word array) */
extern unsigned int TX_BUFFER [1 + TRANSFER_CNT];
extern void INIT_SSC (unsigned int); /* use external routine INIT_SSC */

void INIT_SYS (void); /* prototype definition of routine */

#pragma global /* make key_stat useable for external C modules */

void INIT_SYS (void)
{
    DIR      = 0; /* shift LED light left (init) */
    BITMASK = LED_START_MASK; /* init LED pattern */
    KEY_IDLE = _getbit ( P3, 0 ); /* get key input level (not pressed) */

    _bflld ( DP3, 0x001E, 0x0000 ); /* switch P3.1 - P3.4 to input mode */
    DP2      = ONES; /* switch P2.0 - 2.15 to output mode (LED's) */
    P2       = 0x001E; /* output H on P2.1 - P2.4 */
    BOARD_ID = ( P3 >> 1 ) & 0x000F; /* ...,get the jumper location, shift */
    /* rightbound and store as ID */
    P2       = BOARD_ID << 6; /* show ID on LED panel */

    T6IR     = 0; /* clear Timer6 INT request flag */
    T6IE     = 0; /* and disable Timer 6 interrupt */
    T6       = 0x0000; /* load timer register */
    T6CON    = 0x0047; /* Timer6 counts up, fc=fcpu/512, timer starts */

    while ( ~T6IR ) /* wait for Timer6 overflow */
    {
        if ( T6 & 0x1000 ) /* get flashing LED's @ P2.5 and P2.10 */
            P2 |= 0x0420; /* while waiting for Timer6 overflow */
        else
            P2 &= 0x03C0;
    }
    T6CON = 0x0000; /* stop Timer6 */
    T6IR = 0; /* clear Timer6 interupt request flag */
    _bflld ( T2IC, 0xFF, T2_INT ); /* set Timer2 INT priority & group level */
    T2     = MASTER_IDLE / 0.0128; /* init Timer2 for SSC_SCAN */
    T2CON  = 0x00C5; /* count down, fc=fcpu/256, start timer */
    /* rem.: Timer2 INT disabled, cf. SSC.H */
    _bflld ( T5IC, 0xFF, T5_INT ); /* set Timer5 INT priority & group level */
    T5     = LED_STEP; /* init Timer5 for RUNLIGHT */
}

```



```
T5CON = 0x00C7; /* count down, fc=fcpu/512, start timer */
/* rem.: Timer5 INT enabled, cf. SSC.H */
_bf1d ( T0IC, 0xFF, T0_INT ); /* set Timer0 INT priority & group level */
T0 = 0xFFFF; /* preload timer register */
TOREL = 0xFFFF; /* load reload register */
T01CON = 0x0049 + (char) KEY_IDLE; /* Timer0 as counter, input is P3.0 (HW) */
/* count up at L/H edge if key idle level */
/* is L or at H/L edge if ~ is H */
SRCP0 = (int) & SSCR0; /* PEC0 source is SSC receive buffer reg */
DSTP0 = (int) & RX_BUFFER [0]; /* PEC0 dest is 1st word of rec array */
PECC0 = 0x0000 + 1; /* init PEC0, incr dest, 1 word transfer */
SSCRIC = 0x78; /* set SSC receive interrupt to PEC0 */

SRCP2 = (int) & SSCR2; /* PEC2 source is SSC receive buffer reg */
DSTP2 = (int) & RX_BUFFER [1]; /* PEC2 dest is 1st word of receive array */
PECC2 = 0x200 + TRANSFER_CNT; /* incr dest, transfer defined # of words */

_bf1d ( SSCTIC, 0xFF, SSC_T_INT ); /* set SSC transmit interrupt priority */
/* & group level */

STATUS = SLAVE; /* initial status of board is slave */

SSCCON = 0; /* reset SSC */
SSCBR = ( F_CPU * 1000000 / ( 2 * BAUD_RATE ) ) - 1; /* set baud rate reg */
INIT_SSC ( SLAVE ); /* calls SSC initialization routine */
}
```

4.1.3 SSC initialization - INIT_SSC.C

```

/*****
*   program   : init_ssc.c
*   name      : Andreas Hettmann   Siemens, Cupertino/CA
*   date      : 5'96
*   function  : initializes SSC
*****/

#include <reg167.h>          /* register definitions */
#include "ssc.h"            /* definitions          */

void INIT_SSC (unsigned int); /* prototype definition for routine */

#pragma global             /* make init_ssc useable for external C modules */

void INIT_SSC ( mode )
unsigned int mode;          /* local variable, word type */
{
    SSCCON = ZEROS;         /* stop and reset SSC */

    _bflld ( P3, 0x2300, 0x2300 ); /* set P3.8 (MRST), P3.9 (MTRSR) */
                                   /* and P3.13 (SCLK)          */

    /* _bflld ( ODP3, 0xFFFF, 0x2300 ); */ /* open drain outp only for development */

    switch ( mode )         /* branch depending on value of 'mode' */
    {
        case SLAVE:        _bflld ( DP3, 0x2300, 0x0000 );
                               /* switch MRST,MTRSR and SCLK to input mode */

                               SSCCON = SSC_EN | SSC_SLAVE | SSCCON_INIT;
                               /* init SSC as slave (cf. SSC.H) */
                               break; /* exit branch */

        case MASTER:      _bflld ( DP3, 0x2300, 0x2200 );
                               /* switch MRST to input; MTRSR and SCLK to output mode */

                               SSCCON = SSC_EN | SSC_MASTER | SSCCON_INIT;
                               /* init SSC as master (cf. SSC.H) */
                               break; /* exit branch */
    }
}

```

4.1.4 Key interrupt service routine - KEY_INT.C

```

/*****
* program : key_int.c
* name : Andreas Hettmann Siemens, Cupertino/CA
* date : 5'96
* function : interrupt service routine for push button
*****/

#include <reg167.h> /* register definitions */
#include "ssc.h" /* int # definitions */

extern unsigned int STATUS; /* global variables of word type, def in SSC.C */
extern unsigned int BOARD_ID;
extern bit DIR; /* global variables of bit type, def in SSC.C */
extern bit KEY_IDLE;
extern void INIT_SSC (unsigned int); /* use external routines */
extern void TX_SSC (unsigned int, unsigned int, unsigned int);

interrupt (keyintno) void KEY_INT (void); /* prototype def of routines */
bit SCAN (void);

#pragma global /* make key_int useable for external C modules */

interrupt (keyintno) void KEY_INT ()
{
    unsigned int key = 0, stat, board; /* local variables, word type */
                                        /* key = type of button click */
                                        /* stat = status of board */
                                        /* board = # of remote board */

    T0IE = 0; /* overhead */ /* inhibit INT of Timer0 */
    T0IR = 0; /* overhead */ /* and clear request flag */

    if ( SCAN () ) /* branch if key pressed (filter out spikes) */
    {
        key = SINGLE_CLICK; /* first assumption: single click */

        while ( SCAN () ) /* wait for key release */
        {}

        T6IR = 0; /* clear request flag of Timer6 */
        T6IE = 0; /* and inhibit INT of Timer6 */
        T6 = T_1 / 0.0256; /* [T6] = time to wait for second click */
        T6CON = 0x00C7; /* count down, fc=fcpu/512, timer starts */

        while ( ~T6IR ) /* wait for a second click */
        {
            if ( SCAN () ) /* if second click detected */
                key = DOUBLE_CLICK; /* it was a double click ! */
        }
        T6CON = 0x0000; /* stop Timer6 */
    }
    T0IR = 0; /* overhead */ /* clear request flag of Timer0 */
    T0IE = 1; /* overhead */ /* enable Timer0 interrupt */

    stat = STATUS; /* get STATUS into local var for faster access */
    switch ( key ) /* branch as the type of key stroke */
    {

```

```

case SINGLE_CLICK: T2IE = 0; /* SSC_SCAN off */
    stat++; /* increase status */
    if ( stat > NO_OF_BOARDS - 1 ) /* wrap around */
        stat = 0;
    STATUS = stat; /* put actual status to global var */

    if ( stat == SLAVE ) /* now slave ? */
    {
        INIT_SSC ( SLAVE ); /* init SSC to slave */
        T5IE = 1; /* and enable running LEDs */
    }
    else
    {
        T5IE = 0; /* stop running LEDs */
        P2 = BACKGND_PATTERN | ( stat << STATUS_SHIFT );
        /* and show actual status on LEDs */
        if ( stat == MASTER ) /* was slave ? */
        {
            _putbit ( 1, DP3, 8 ); /* switch MRST to output */
            TX_SSC ( MASTER_REQ, BOARD_ID, ALL );
            /* send master req */
        }
        T2IE = 1; /* switch SSC_SCAN on */
    }
    break;

case DOUBLE_CLICK: if ( stat == SLAVE ) /* status eq slave ? */
    DIR = ~DIR; /* toggle direction of running LEDs */
    else
    {
        board = stat + BOARD_ID; /* calc # of remote board */
        if ( board > NO_OF_BOARDS - 1 )
            board -= NO_OF_BOARDS;

        TX_SSC ( DIR_CHG, BOARD_ID, board );
        /* and send command ... */
        /* to remote board to toggle running LED direction */
    }
    break;
}
}
bit SCAN (void)
{
    int cnt = 0, status = 0; /* local variables, word type */
    /* cnt = # of key scans */
    /* status = key input value */

    T4IR = 0; /* clear request flag of Timer4 */
    T4IE = 0; /* and inhibit INT of Timer4 */
    T4 = T_2 / 0.0256; /* [T4] = key scanning time */
    T4CON = 0x00C6; /* count down, fc=fcpu/512, start timer */

    while ( ~T4IR ) /* while Timer4 not expired */
    {
        status += _getbit ( P3, 0 ); /* accumulate key values */
        cnt++; /* and count loop cycles */
    }
    T4CON = 0x0000; /* stop Timer4 */

    if ( (cnt - status) < status ) /* key pressed for more than 50% of time ? */

```

```
    return ( P30_ACTIVE ^ KEY_IDLE );  
else  
    return ( P30_PASSIVE ^ KEY_IDLE );  
}
```

4.1.5 Running LED light - RUNLIGHT.C

```

/*****
*   program   : runlight.c
*   name      : Andreas Hettmann   Siemens, Cupertino/CA
*   date      : 5'96
*   function  : LED runlight interrupt service routine
*****/

#include <reg167.h>          /* register definitions */
#include "ssc.h"            /* int # definitions */

extern bit DIR;            /* global variables of bit and word type, def in SSC.C */
extern unsigned int BITMASK;

interrupt (t5intno) void RUNLIGHT (void);          /* prototype of routine */

#pragma global                /* make runlight useable for external C modules */

interrupt (t5intno) void RUNLIGHT (void)
{
    unsigned int mask;          /* local variable, word type */
                                /* mask = current LED output */
    mask = BITMASK;           /* get bitmask into local var for faster access */

    if ( DIR )                /* shift LEDs depending on current direction flag DIR */
        mask = _ror ( mask, 1 );
    else
        mask = _rol ( mask, 1 );

    T5      = LED_STEP / 0.0256;          /* reload Timer5 for running LEDs */

    P2 = mask;                    /* output computed bitmask to LEDs */

    BITMASK = mask;              /* and store new value back in global variable */
}

```

4.1.6 SSC scan routine - SSC_SCAN.C

```

/*****
*   program   : ssc_scan.c
*   name      : Andreas Hettmann   Siemens, Cupertino/CA
*   date      : 5'96
*   function  : Master SSC scanning for Slave commands
*****/

#include <reg167.h>          /* register definitions */
#include "ssc.h"            /* int # definitions */

extern unsigned int BOARD_ID;
extern void TX_SSC (unsigned int, unsigned int, unsigned int);
/* use external routine */

interrupt (t2intno) void SSC_SCAN (void); /* prototype definition */

#pragma global             /* make ssc_scan useable for external C modules */

interrupt (t2intno) void SSC_SCAN (void)
{
    TX_SSC ( IDLE, BOARD_ID, ALL ); /* send command IDLE to all remote boards */
/* rem.: this procedure is needed to */
/* supply all slaves with SSC clock */
/* periodically to ensure a slave request */
/* can be received by the master */

    T2      = MASTER_IDLE / 0.0128; /* reload timer */
    T2CON = 0x00C5; /* count down, fc=fcpu/256, start timer */
}

```

4.1.7 SSC receive interrupt service routine - RX_INT.C

```

/*****
* program   : rx_int.c
* name      : Andreas Hettmann   Siemens, Cupertino/CA
* date      : 5'96
* function  : interrupt service routine SSC receive
*****/

#include <reg167.h>          /* register definitions */
#include "ssc.h"             /* definitions */

extern bit DIR;             /* global variables of bit and word type, def in SSC.C */
extern unsigned int STATUS;
extern unsigned int BOARD_ID;
extern unsigned int RX_BUFFER [1 + TRANSFER_CNT];
extern void TX_SSC (unsigned int, unsigned int, unsigned int);
extern void INIT_SSC (unsigned int);          /* use external routines */

interrupt (rxintno) void RX_INT (void);     /* prototype of routine */

#pragma global                          /* make rx_int useable for external C modules */

interrupt (rxintno) void RX_INT ()
{
    unsigned int rec_word, rx_src, rx_dest, rx_msg;
                                /* local vars, word type */

    PECC0 = 0x0000 + 1;         /* prepare PEC0 for receiving of next word via SSC */

    if (( SSCRIC & 0x3F ) == 0x3A ) /* last transfer SSCRIB -> mem via PEC2 ? */
    {
        _bflld ( SSCRIC, 0x3F, 0x38 );          /* then switch back to PEC0 */
        DSTP2 = (int) & RX_BUFFER [1];
                                /* PEC2 destination is 1st word of receive array */
        PECC2 = 0x200 + TRANSFER_CNT;
                                /* increment dest, transfer defined # of words */
    }
    else
    {
                                /* (last transfer via PEC0) */
        rec_word = RX_BUFFER [0];          /* get rec value into local var */
        rx_src = (rec_word & 0x0F00) >> 8;
        rx_dest = (rec_word & 0x00F8) >> 3;          /* get received address */
        rx_msg = rec_word & 0x0007;          /* get received command */

        if ( ((rec_word & 0xF000) != HEADER) ||
              ((rx_dest != ALL) && (rx_dest != BOARD_ID)) )
            /* header incorrect or received data */
            return;          /* doesn't belong to this board -> return */

        switch ( rx_msg )          /* branch as the command */
        {
            case DIR_CHG:          SSCRIC = 0x7A;          /* SSC rec INT now served by PEC2 */
                                DIR = ~DIR;          /* toggle running LED direction */
                                break;
        }
    }
}

```



```
case MASTER_REQ: if ( STATUS != SLAVE )      /* is current master for */
                 {                          /* any remote board ?    */
                 T2IE = 0;
                 TX_SSC ( OK, BOARD_ID, rx_src );
                 STATUS = SLAVE;             /* status becomes 'slave' */
                 INIT_SSC ( SLAVE );        /* init SSC as slave */
                 T5IE = 1;                  /* switch on running LEDs */
                 }
                 break;

case OK:          if ( rx_dest == BOARD_ID )
                 {
                 INIT_SSC ( MASTER );
                 T2IE = 1;
                 }
                 break;

case IDLE:       break;                    /* rec word ist from scanning master */
}
}
}
```

4.1.8 SSC transmit routine - TX_SSC.C

```

/*****
*   program   : tx_ssc.c
*   name      : Andreas Hettmann   Siemens, Cupertino/CA
*   date      : 5'96
*   function  : SSC TX routines
*****/

#include <reg167.h>          /* register definitions */
#include "ssc.h"            /* int # definitions */

extern unsigned int TX_BUFFER [1 + TRANSFER_CNT];          /* global word array */

void TX_SSC (unsigned int, unsigned int, unsigned int);    /* prototype def */

#pragma global          /* make tx_ssc useable for external C modules */

void TX_SSC ( cmd, src, dest )
unsigned int cmd, src, dest;          /* local variables, word type */
/* cmd = command to be transmitted */
/* dest = address of destination board */
{
  if ( cmd == DIR_CHG )              /* command for remote board to toggle */
/* direction of running LEDs ? */
  {
    SRCP1 = (int) & TX_BUFFER [1];
/* PECl source is 1st word of transmit buffer array */
    DSTP1 = (int) & SSCTB;          /* PECl destination is SSC transmit buffer reg */
    PECC1 = 0x400 + TRANSFER_CNT;
/* increment source address, transfer defined # of words */
    SSCTIC = 0x79;                  /* SSC transmit interrupt now served by PECl */
  }

  SSCTB = TX_BUFFER [0] = HEADER | ( src << 8 ) | ( dest << 3 ) | cmd;
/* build transmit word with header, address and command */
/* and write it into SSC transmit register. */
/* In master mode the transmission starts instantly, in */
/* slave mode the transmission starts when the remote */
/* master is transmitting */
}

```

4.1.9 SSC transmit interrupt service routine - TX_INT.C

```

/*****
*   program   : tx_int.c
*   name      : Andreas Hettmann   Siemens, Cupertino/CA
*   date      : 5'96
*   function  : interrupt service routine SSC transmit
*****/

#include <reg167.h>          /* register definitions */
#include "ssc.h"            /* definitions */

extern void INIT_SSC (unsigned int);
interrupt (txintno) void TX_INT (void); /* prototype definition */

#pragma global             /* make tx_int useable for external C modules */

interrupt (txintno) void TX_INT ()
{
    T3IR = 0;                /* clear Timer3 interrupt request flag */
    T3    = WAIT_FOR_MASTER / 0.0256; /* [T3] = time to wait for remote master */
    T3CON = 0x00C6;          /* count down, fc=fcpu/512, start timer */

    while ( SSCBSY && ~T3IR ) /* wait for one of the following events: */
    {                          /* - remote master got transmitted word by */
                              /* - supplying SSC clock for the board or */
                              /* - all other boards are in slave mode too, no */
                              /* - remote master with SSC clock available, */
                              /* - timer expires. Sending of command not */
                              /* - necessary. */

        if ( T3IR )
        {
            INIT_SSC ( MASTER );
            T2IE = 1;
        }

        T3CON = 0x0000; /* stop Timer6 */

        _bfd ( SSCTIC, 0xFF, SSC_T_INT ); /* next SSC receive interrupt */
                                          /* calls interrupt service routine */
                                          /* tx_int, no transfer via PECl */

        _putbit ( 0, DP3, 8 ); /* switch MRST to input mode */
                                /* rem.: in master mode already */
                                /* assigned, in slave mode assures */
                                /* that all inactive slave SSCs have */
                                /* high impedance TX output pins */
    }
}

```

4.1.10 C header file - SSC.H

```

#define NO_OF_BOARDS      3           /* # of boards being supported (max. 16) */

#define mainintno        0x50        /* software int for main program ssc.c */
#define keyintno         0x20        /* hardware interrupt # of Timer0 */
#define t2intno          0x22        /* hardware interrupt # of Timer2 */
#define t5intno          0x25        /* hardware interrupt # of Timer5 */
#define rxintno          0x2E        /* hardware interrupt # of SSC receive */
#define txintno          0x2D        /* hardware interrupt # of SSC transmit */

#define ENABLE_INT       0x40        /* sets xxxIE */ /* ILVL  GLVL */
#define T2_INT           4 * 0x09 + 0x00
#define T5_INT           ENABLE_INT + 4 * 0x06 + 0x00
#define T0_INT           ENABLE_INT + 4 * 0x07 + 0x00
#define SSC_T_INT        ENABLE_INT + 4 * 0x08 + 0x00

#define SLAVE            0           /*
#define MASTER          1           /* const 'MASTER' defines ONLY the status
                                   /* after being slave !

#define KEY_NOT_PRESSED 0           /* consts for routine key_int */
#define SINGLE_CLICK    1
#define DOUBLE_CLICK    2

#define P30_PASSIVE     0           /* const for routine scan (key) */
#define P30_ACTIVE      1

#define T_1             300        /* msec, max. time betw. 2 clicks (dbl click) */
#define T_2             3          /* msec, key scanning time to detect spikes */
#define LED_STEP        50         /* msec, time step for running LEDs */
#define MASTER_IDLE     50         /* msec, scan every ~ for slave's requests */
#define WAIT_FOR_MASTER 500        /* msec, slave waits for remote master */
#define BACKGND_PATTERN 0xF81F    /* background LED pattern in master mode */
#define STATUS_SHIFT    6          /* displayed board # fits into pattern */

#define HEADER          0x5000     /* shifted header for SSC transmission */
#define IDLE            0x00       /* dummy command for ssc_scan */
#define DIR_CHG         0x05       /* command 'toggle dir of running LEDs' */
#define MASTER_REQ      0x07       /* request from slave to become master */
#define OK              0x02
#define ALL             0x10       /* address for broadcasting */
#define TRANSFER_CNT    16         /* words transferred data after DIR_CHG */

#define SSC_EN          0x8000     /* SSC enable bit SSCCON.15 */
#define SSC_SLAVE       0x0000     /* init values for register SSCCON (slave) */
#define SSC_MASTER      0x4000     /* (master) */
#define SSCCON_INIT     0x005F     /* SSC: MSB first, 16 bits data ea. TX/RX */
#define F_CPU           20         /* MHz, system clock frequency */
#define BAUD_RATE       115200     /* bd, SSC baud rate

#define LED_START_MASK  0x0707    /* running LED starts with this pattern

```

4.2 System register initialization, ASM code - INIT_167.SRC

```

$DEBUG
$SYMBOLS
$XREF
$SEGMENTED
$EXTEND
$NOMOD166
$STDNAMES(reg167b.def) ;all C167 SFR's & Bit names
;----- end of primary controls ----- program header: --
;*****
;* program : INIT_167.SRC *
;* name : Harald Lehmann, Siemens, Cupertino/CA *
;* date : 12'95 *
;* function : System Initialization large memory model (SEGMENTED) *
;*****
;----- definitions: --
NAME init_167_segmented ;Modulname

        JMP_MAIN      EQU 50H          ;SW-interrupt for MAIN program

;----- system configuration for EVAL167: --
;----- externals, public: --
;----- stack, PEC, register: --
        SSKDEF 001b ;128 Words
Init_RB      REGBANK R0 ;not need just as an example

;----- CGROUPs, DGROUPs: --
ROM_C_Group CGROUP Init_sec

;----- code: --
Init_sec      SECTION      CODE      'INIT_ROM'
Init_proc     PROC        TASK      Init_167_Tsk      INTNO      Init_167_Int

        ASSUME DPP3:SYSTEM

        MOV DPP3,#3d ;system datapage RESET Value
        NOP ;necessary for the next instruction

        ;system configuration SYSCON, BUSCON0, BUSCON1 and BUSCON2:

        MOV SYSCON, #00100001000000100b ;(2104H)
        ;^^^^||| |^^^^^| | |XPER-SHARE: 0 = no share of X-Periph
        ;^^^^||| |^^^^^| | |+VISIBLE: 0= no visible mode for XPeriph
        ;^^^^||| |^^^^^| | |XRAMEN: 1 = XRAM selected
        ;^^^^||| |^++++ -- don't care
        ;^^^^||| |+ WRCFG: write configuration
        ;^^^^||| |+ CLKEN: 1 = ENables system clock output on P3.15
        ;^^^^||| |+ BYTDIS: 0 = BHE ENable
        ;^^^^||| |+ ROMEN: 0 = int. ROM DISable
        ;^^^^+ SGTDIS: 0 = segmented memory model ON
        ;^^^+ ROMS1: 0 = NO ROM mapping to segment 1
        ;+++ STKSZ: 001 = 128 Words system stack size

        MOV BUSCON0, #0000010010111111b ;(04BFH)
        ;^^^^||| |^^^^^++++ MCTC 1111 = 0 WS
        ;^^^^||| |^^^+ RWDC0 1 = NO delay
        ;^^^^||| |^^+ MTTC0 0 = 1 WS, 1 = 0 WS

```

```

;^^^^| ||| ++ BTYP bus mode: 16 Bit, DEMUX
;^^^^| ||| + -- don't care
;^^^^| | + ALECTL0 0 = NO ALE lengthening
;^^^^| + BUSACT0 1 = enables the BUSCONx function
;^^^^+ -- don't care
;^^^+ RDYEN0 0 = DISables the READY# function
;^^+ -- don't care
; ++ = 00 always 0 for BUSCON0

MOV BUSCON1,    #0000010010111111b    ;(04BFH)
;^^^^| ||| ^^^^^++++ MCTC 1111 = 0 WS
;^^^^| ||| ^^^+ RWDC0 1 = NO delay
;^^^^| ||| ^^+ MTTC0 0 = 1 WS, 1 = 0 WS
;^^^^| ||| ++ BTYP bus mode: 16 Bit, DEMUX
;^^^^| ||| + -- don't care
;^^^^| | + ALECTL0 0 = NO ALE lengthening
;^^^^| + BUSACT0 1 = enables the BUSCONx function
;^^^^+ -- don't care
;^^^+ RDYEN0 0 = DISables the READY# function
;^^+ -- don't care
; ++ = 00 = address chip select

MOV ADDRSEL1,  #00000000000000100b    ;(0004H)
;^^^^| ||| ^^^^^++++ 64K range size
;+++++start address at 00 0000 (1st 64K-block)

;MOV BUSCON2,  #0000010001111101b    ;(047DH) EXAMPLE NOT NEEDED!
;^^^^| ||| ^^^^^++++ MCTC 1110 = 1 WS
;^^^^| ||| ^^^+ RWDC1 0= with delay
;^^^^| ||| ^^+ MTTC1 1= 0 WS
;^^^^| ||| ++ BTYP bus mode: 8Bit MUX
;^^^^| ||| + -- don't care
;^^^^| | + ALECTL1 0= NO ALE lengthening
;^^^^| + BUSACT1 1 = enables the BUSCONx function
;^^^^+ -- don't care
;^^^+ RDYEN1 0= DISables the READY# function
;^^+ -- don't care
; ++ = 00 = address chip select

;MOV ADDRSEL2,  #0001000000010000b    ;(1010H) EXAMPLE NOT NEEDED!
;^^^^| ||| ^^^^^++++ 4K range size
;+++++start address at 10 1000 (2nd 4K-block 1M-border)
MOV CP,#Init_RB ; overwrites default value
;NOP is not necessary for the next instruction

; SP    = FC00 = reset value (Stack Pointer)
; STKUN = FC00 = reset value (STack UNDERflow)
; MOV STKOV,#0FC00H+512 ;STack OVerflow at base +(128 Word = 256Bytes)

DISWDT                ;disable watchdog timer

EINIT                 ;end of initialization

MOV DPP0,#2d         ;page for data

TRAP #JMP_MAIN       ;jump to main program

STAY_IDLE:
IDLE                  ;IDLE-MODE should never reached, smthg wrong!

```

```
JMP STAY_IDLE           ;NEVERENDING stay in IDLE mode forever  
  
RETV                   ;to avoid the warning 'missing return'  
  
Init_proc             ENDP  
Init_sec              ENDS  
;----- end -----  
END
```

4.3 Linker and locater control file - SSC.ILO

```

;***** SSC.ILO ***** (for the EVAL67-monitor of HITEX)

TASK          INTNO = 0          ;task-name, Nr. 0 = RESET
INIT_167.lno  ;filename [.LNO]

TASK          INTNO = 50h        ;Task-Name, Int.Name + Nr.= SW-INTERRUPT
SSC.lno      ;filename [.LNO]
INIT_SYS.lno
INIT_SSC.lno
TX_SSC.lno

TASK          INTNO = 20h        ;Task-Name, Int.Name + Nr.= TIMER0-INTERRUPT
KEY_INT.lno  ;filename [.LNO]

TASK          INTNO = 22h        ;Task-Name, Int.Name + Nr.= TIMER2-INTERRUPT
SSC_SCAN.lno ;filename [.LNO]

TASK          INTNO = 25h        ;Task-Name, Int.Name + Nr.= TIMER5-INTERRUPT
RUNLIGHT.lno ;filename [.LNO]

TASK          INTNO = 2Dh        ;Task-Name, Int.Name + Nr.= SSC-TX-INTERRUPT
TX_INT.lno   ;filename [.LNO]

TASK          INTNO = 2Eh        ;Task-Name, Int.Name + Nr.= SSC-RX-INTERRUPT
RX_INT.lno   ;filename [.LNO]

IRAMSIZE(2048)          ;Internal RAM size is 2 KBytes for C167

CLASSES ('INIT_ROM' (0A100H-0A200H)) ;code of INIT_167 source file, start up
CLASSES ('CPROGRAM' (0A300H-0AFFFH)) ;code area for all C modules
CLASSES ('CNEAR' (0B000H-0B1FFH)) ;byte & word variables and arrays
CLASSES ('CINITROM' (0B200H-0B3FFH)) ;
;CLASSES ('CUSTACK' (0B400H-0B5FFH)) ;not needed here (C user stack)
CLASSES ('CBITS' (0FD00H-0FD01H)) ;bit variables

VECTAB (1000H)          ; user interrupt vector table location

;Memory reservation for EVAL67/165 with HITEX Monitor Telemon 167

RESERVE ( MEMORY (00000H-00221H,
                  01200H-0A00AH,
                  0FA00H-0FA3FH,
                  0FCC0H-0FCDFH))

```

4.4 Locater output file - SSC.MAP

80166 linker/locator v5.0 r0
ssc

SN070076-042

Date: May 17 1996 T

Memory map :

Name	No.	Start	End	Length	Type	Algn	Comb	Mem	T	Group	Class
Reserved.....	...	000000h	000221h	000222h
?INTVECT.....	...	001000h	001003h	000004h	ROM
?INTVECT.....	...	001080h	001083h	000004h	ROM
?INTVECT.....	...	001088h	00108Bh	000004h	ROM
?INTVECT.....	...	001094h	001097h	000004h	ROM
?INTVECT.....	...	0010B4h	0010B7h	000004h	ROM
?INTVECT.....	...	0010B8h	0010BBh	000004h	ROM
?INTVECT.....	...	001140h	001143h	000004h	ROM
Reserved.....	...	001200h	00A00Ah	008E0Bh
Init_sec.....	0	00A100h	00A12Dh	00002Eh	CODE	WORD	PRIV	ROM	P	ROM_C_Group	INIT_ROM.
SSC_3_PR.....	6	00A300h	00A325h	000026h	CODE	WORD	PUBL	ROM	CPROGRAM.
INIT_SYS_1_PR.....	8	00A320h	00A3FFh	0000E0h	CODE	WORD	PUBL	ROM	CPROGRAM.
INIT_SSC_1_PR.....	9	00A400h	00A425h	000026h	CODE	WORD	PUBL	ROM	CPROGRAM.
TX_SSC_1_PR.....	10	00A426h	00A45Fh	00003Ah	CODE	WORD	PUBL	ROM	CPROGRAM.
KEY_INT_1_PR.....	11	00A460h	00A587h	000128h	CODE	WORD	PUBL	ROM	CPROGRAM.
SSC_SCAN_1_PR.....	13	00A588h	00A5C7h	000040h	CODE	WORD	PUBL	ROM	CPROGRAM.
RUNLIGHT_1_PR.....	15	00A5C8h	00A605h	00003Eh	CODE	WORD	PUBL	ROM	CPROGRAM.
TX_INT_1_PR.....	16	00A606h	00A653h	00004Eh	CODE	WORD	PUBL	ROM	CPROGRAM.
RX_INT_1_PR.....	18	00A654h	00A72Dh	0000DAh	CODE	WORD	PUBL	ROM	CPROGRAM.
RX_INT_2_NB.....	19	00B000h	000000h	DATA	WORD	PUBL	RAM	P	C166_DGROUP	CNEAR....
TX_INT_2_NB.....	17	00B000h	000000h	DATA	WORD	PUBL	RAM	P	C166_DGROUP	CNEAR....
SSC_SCAN_2_NB.....	14	00B000h	000000h	DATA	WORD	PUBL	RAM	P	C166_DGROUP	CNEAR....
KEY_INT_2_NB.....	12	00B000h	000000h	DATA	WORD	PUBL	RAM	P	C166_DGROUP	CNEAR....
SSC_1_NB.....	4	00B000h	00B049h	00004Ah	DATA	WORD	PUBL	RAM	P	C166_DGROUP	CNEAR....
C166_BSS.....	7	00B200h	00B209h	00000Ah	DATA	WORD	GLOB	ROM	CINITROM.
Extended SFR Area.....	...	00F000h	00F1FFh	000200h	RAM
ESFR_AREA.....!	3	00F000h	00F1D7h	0001D8h	DATA	WORD	AT..	RAM	P	DATAGRP
Reg. bank 0.....	...	00F600h	00F601h	000002h	WORD	RAM
Reg. bank 1.....	...	00F602h	00F621h	000020h	WORD	RAM
Reg. bank 2.....	...	00F622h	00F641h	000020h	WORD	RAM
Reg. bank 3.....	...	00F642h	00F661h	000020h	WORD	RAM
Reg. bank 4.....	...	00F662h	00F681h	000020h	WORD	RAM
Reg. bank 5.....	...	00F682h	00F6A1h	000020h	WORD	RAM
Reg. bank 6.....	...	00F6A2h	00F6C1h	000020h	WORD	RAM
Reserved.....	...	00FA00h	00FA3Fh	000040h
System Stack.....	...	00FB00h	00FBFFh	000100h	RAM

Reserved.....	00FCC0h	00FCDFh	000020h
SFR_AREA1.....	1 00FCE0h	00FCFFh	000020h	DATA	WORD	AT..	RAM	P	DATAGRP.....
SSC_2_BI.....	5 00FD00h.00	00FD00h.01	000002h	BIT	BIT	PUBL	RAM		CBITS.....
SFR Area.....	00FE00h	00FFFFh	000200h	RAM	
SFR_AREA.....!	2 00FE00h	00FFD7h	0001D8h	DATA	WORD	AT..	RAM	P	DATAGRP.....

Interrupt table:

Vector	Intno	Start	Intnname	Taskname
0000000h	0000h	000A100h	Init_167_Int.....	Init_167_Tsk.....
0000080h	0020h	000A460h	KEY_INT_INUM.....	KEY_INT_TASK.....
0000088h	0022h	000A588h	SSC_SCAN_INUM.....	SSC_SCAN_TASK.....
0000094h	0025h	000A5C8h	RUNLIGHT_INUM.....	RUNLIGHT_TASK.....
00000B4h	002Dh	000A606h	TX_INT_INUM.....	TX_INT_TASK.....
00000B8h	002Eh	000A654h	RX_INT_INUM.....	RX_INT_TASK.....
0000140h	0050h	000A300h	SSC_INUM.....	SSC_TASK.....

Error report : W 141: module INIT_167.lno(init_167): overlapping memory ranges 'SFR_AREA' and 'SFR Area'
W 141: module INIT_167.lno(init_167): overlapping memory ranges 'ESFR_AREA' and 'Extended S'
total errors: 0, warnings: 2

4.5 Miscellaneous files for compiling

FILE MAKE.BAT:

```
mk166 -f ssc.mak >error.txt
```

FILE SSC.MAK:

```
# Makefile "ssc.mak" made by A.Hettmann, Siemens, Cupertino, CA, 03/96
# This is for the HITEX simulator LIGHT and the BSO/T.
# You need these kind of enviroment:
# > PATH c:\BAT;C:\DOS;C:\;D:\NC;C:\...\TASKING\c166\BIN;C:\...\hitex\sim
# > set C166INC=c:\...\tasking\c166\include
# > set C166LIB=c:\...\tasking\c166\LIB\NP
# > set TMPDIR=C:\TEMP

# **** CREATE HITEX-FILES ****
# This is done with Symbol preprocessor T C166 V2.31 "SP166TA.EXE"
ssc.sym: ssc.695
\166\hitex\tools\pp166ta.231\sp166ta ssc.695 -v -fo

# IEEE695-FILTER
ssc.695: ssc.out
ieee166 ssc.out ssc.695
# HEX-CONVERTER *** CREATE HEX-FILES ***
ihex166 ssc.out ssc.hex

# LOCATER
# *** CREATE AN ABSOLUTE OBJEKT-FILE ***
ssc.out: init_167.lno ssc.lno init_ssc.lno key_int.lno rx_int.lno tx_int.lno
runlight.lno ssc_scan.lno init_sys.lno tx_ssc.lno ssc.ilo
L166 @ssc.ilo NOVECINIT to ssc.out

# LINKER
init_167.lno: init_167.obj
L166 init_167.obj sg_sfrta.obj to init_167.lno
ssc.lno: ssc.obj
L166 ssc.obj to ssc.lno
init_ssc.lno: init_ssc.obj
L166 init_ssc.obj to init_ssc.lno
key_int.lno: key_int.obj
L166 key_int.obj to key_int.lno
rx_int.lno: rx_int.obj
L166 rx_int.obj to rx_int.lno
tx_int.lno: tx_int.obj
L166 tx_int.obj to tx_int.lno
runlight.lno: runlight.obj
L166 runlight.obj to runlight.lno
ssc_scan.lno: ssc_scan.obj
L166 ssc_scan.obj to ssc_scan.lno
init_sys.lno: init_sys.obj
L166 init_sys.obj to init_sys.lno
tx_ssc.lno: tx_ssc.obj
L166 tx_ssc.obj to tx_ssc.lno

# ASSEMBLER FOR MAINPROGRAM
```

```
ssc.obj: ssc.src
A166 ssc.src DB EP CASE

# ASSEMBLER FOR SSC INIT
init_ssc.obj: init_ssc.src
A166 init_ssc.src DB EP CASE

# ASSEMBLER FOR KEY INTERRUPT SERVICE ROUTINE
key_int.obj: key_int.src
A166 key_int.src DB EP CASE

# ASSEMBLER FOR RECEIVE INTERRUPT SERVICE ROUTINE
rx_int.obj: rx_int.src
A166 rx_int.src DB EP CASE

# ASSEMBLER FOR TRANSMIT INTERRUPT SERVICE ROUTINE
tx_int.obj: tx_int.src
A166 tx_int.src DB EP CASE

# ASSEMBLER FOR LED RUNLIGHT INTERRUPT SERVICE ROUTINE
runlight.obj: runlight.src
A166 runlight.src DB EP CASE

# ASSEMBLER FOR SSC SCAN INTERRUPT SERVICE ROUTINE
ssc_scan.obj: ssc_scan.src
A166 ssc_scan.src DB EP CASE

# ASSEMBLER FOR SYSTEM INIT
init_sys.obj: init_sys.src
A166 init_sys.src DB EP CASE

# ASSEMBLER FOR TRANSMIT ROUTINE
tx_ssc.obj: tx_ssc.src
A166 tx_ssc.src DB EP CASE
# C-COMPILER FOR MAINPROGRAM
ssc.src: ssc.c ssc.h
C166 -gf -t -Ml -x -s ssc.c

# C-COMPILER FOR SSC INIT
init_ssc.src: init_ssc.c ssc.h
C166 -gf -t -Ml -x -s init_ssc.c

# C-COMPILER FOR KEY INTERRUPT SERVICE ROUTINE
key_int.src: key_int.c ssc.h
C166 -gf -t -Ml -x -s key_int.c

# C-COMPILER FOR RECEIVE INTERRUPT SERVICE ROUTINE
rx_int.src: rx_int.c ssc.h
C166 -gf -t -Ml -x -s rx_int.c

# C-COMPILER FOR TRANSMIT INTERRUPT SERVICE ROUTINE
tx_int.src: tx_int.c ssc.h
C166 -gf -t -Ml -x -s tx_int.c

# C-COMPILER FOR LED RUNLIGHT INTERRUPT SERVICE ROUTINE
runlight.src: runlight.c ssc.h
C166 -gf -t -Ml -x -s runlight.c

# C-COMPILER FOR SSC SCAN INTERRUPT SERVICE ROUTINE
```

```
ssc_scan.src: ssc_scan.c ssc.h
C166 -gf -t -M1 -x -s ssc_scan.c
```

```
# C-COMPILER FOR SYSTEM INIT
init_sys.src: init_sys.c ssc.h
C166 -gf -t -M1 -x -s init_sys.c
```

```
# C-COMPILER FOR TRANSMIT ROUTINE
tx_ssc.src: tx_ssc.c ssc.h
C166 -gf -t -M1 -x -s tx_ssc.c
```

```
# ASSEMBLER FOR INIT
init_167.obj: init_167.src
A166 init_167.src DB EP CASE
```

FILE SETPATH.BAT:

```
PROMPT
rem *****
rem *           "setpath.bat" prepare the enviroment for           *
rem *           the PECR167 demo on the EVAL167 kit with           *
rem *           Tasking 166 Evaluation Package                       *
rem *           *** SAB-C167 ***                                     *
rem *           Harald Lehmann, SIEMENS, cupertino 11'95           *
rem *****
path=%PATH%;c:\166\TASKING\BIN;c:\EVAL167\HITEX;c:\EVAL167\HITEX\EXAMPLE
set CCDEMO=c:\EVAL167\TASKING
set C166INC=c:\EVAL167\TASKING\include
set LINK166=LIBPATH(c:\166\TASKING\lib\EXT) c166t.lib
set LOCATE166=CASE
prompt $p$g
```

FILE BOOT.BAT:

```
\eval167\hitex\btld eval167.hex -r
```

FILE BTDL.CFG:

```
// configuration file for BTLD bootstrap loader for Siemens 16x V1.00
// Copyright (c) 1994                               Hitex Systementwicklung GmbH
//
// supported keywords and values:
// COM           communication port, selection out of (1, 2)
// BAUD          baudrate, selection out of 9600/19200/38400
// TYPE          type of processor, selection out of
//              (0 = 8xC166, 1 = C165/C167)
// SYSCON        hexadecimal value of register SYSCON to be loaded
// BUSCON0       hexadecimal value of register BUSCON0 to be loaded
// BUSCON1       hexadecimal value of register BUSCON1 to be loaded
// ADDRSEL1      hexadecimal value of register ADDRSEL1 to be loaded
// BUSCON2       hexadecimal value of register BUSCON2 to be loaded
// ADDRSEL2      hexadecimal value of register ADDRSEL2 to be loaded
// BUSCON3       hexadecimal value of register BUSCON3 to be loaded
```

```

// ADDRSEL3    hexadecimal value of register ADDRSEL3 to be loaded
// BUSCON4     hexadecimal value of register BUSCON4 to be loaded
// ADDRSEL4    hexadecimal value of register ADDRSEL4 to be loaded
//
// the default value of not named busconfiguration registers is 0000
//
COM          1
BAUD        38400
TYPE        1          // C167
SYSCON      2100
ADDRSEL1    4
BUSCON0     04BF
BUSCON1     04BF
//
//      MOV SYSCON,      #0010000100000000b      ;(2100H)
//                      ;^ ^ ^ ^ | | | | ^ ^ ^ ^ | | | | +XPER-SHARE: 0 = no share of X-Periph
//                      ;^ ^ ^ ^ | | | | ^ ^ ^ ^ | | | | +VISIBLE: 0= no visible mode for XPeriph
//                      ;^ ^ ^ ^ | | | | ^ ^ ^ ^ | | | | +XRAMEN: 0 = XRAM deselected
//                      ;^ ^ ^ ^ | | | | ^ + + + + -- don't care
//                      ;^ ^ ^ ^ | | | | + WRCFG: write configuration
//                      ;^ ^ ^ ^ | | | | + CLKEN:1 = ENables system clock output on P3.15
//                      ;^ ^ ^ ^ | | | | + BYTDIS: 0 = BHE ENable
//                      ;^ ^ ^ ^ | | | | + ROMEN: 0 = int. ROM DISable
//                      ;^ ^ ^ ^ + SGTDIS: 0 = segmented memory model ON
//                      ;^ ^ ^ + ROMS1: 0 = NO ROM mapping to segment 1
//                      ; + + + + STKSZ: 001 = 128 Words system stack size
//
//      MOV BUSCON0,     #0000010010111111b      ;(04BFH)
//                      ;^ ^ ^ ^ | | | | ^ ^ ^ ^ + + + + MCTC 1111 = 0 WS
//                      ;^ ^ ^ ^ | | | | ^ ^ ^ + RWDC0 1 = NO delay
//                      ;^ ^ ^ ^ | | | | ^ ^ + MTTC0 0 = 1 WS, 1 = 0 WS
//                      ;^ ^ ^ ^ | | | | ++ BTYP bus mode: 16 Bit, DEMUX
//                      ;^ ^ ^ ^ | | | | + -- don't care
//                      ;^ ^ ^ ^ | | | | + ALECTL0 0 = NO ALE lengthening
//                      ;^ ^ ^ ^ | | | | + BUSACT0 1 = enables the BUSCONx function
//                      ;^ ^ ^ ^ + -- don't care
//                      ;^ ^ ^ + RDYEN0 0 = DISables the READY# function
//                      ;^ ^ + -- don't care
//                      ; ++ = 00 always 0 for BUSCON0
//
//
//      MOV BUSCON1,     #0000010010111111b      ;(04BFH)
//                      ;^ ^ ^ ^ | | | | ^ ^ ^ ^ + + + + MCTC 1111 = 0 WS
//                      ;^ ^ ^ ^ | | | | ^ ^ ^ + RWDC0 1 = NO delay
//                      ;^ ^ ^ ^ | | | | ^ ^ + MTTC0 0 = 1 WS, 1 = 0 WS
//                      ;^ ^ ^ ^ | | | | ++ BTYP bus mode: 16 Bit, DEMUX
//                      ;^ ^ ^ ^ | | | | + -- don't care
//                      ;^ ^ ^ ^ | | | | + ALECTL0 0 = NO ALE lengthening
//                      ;^ ^ ^ ^ | | | | + BUSACT0 1 = enables the BUSCONx function
//                      ;^ ^ ^ ^ + -- don't care
//                      ;^ ^ ^ + RDYEN0 0 = DISables the READY# function
//                      ;^ ^ + -- don't care
//                      ; ++ = 00 = address chip select
//
//      MOV ADDRSEL1,    #0000000000000100b      ;(0004H)
//                      ;^ ^ ^ ^ | | | | ^ ^ ^ ^ + + + + 64K range size
//                      ; + + + + + + + + + + start address at 00 0000 (1st 64K-block)

```

FILE HIT1.BAT:

```
\166\hitex\mon\hit_167.exe -p1 -b384 -y -rhit_167.rst
```

```
REM used command line parameters for HIT_167.EXE:  
REM -p1 COM1 for communication  
REM -b384 38400 baud  
REM -y assume YES for reloading of recent used files  
REM -rhit_167.rst use restore file hit_167.rst
```

5 LED display board - schematic

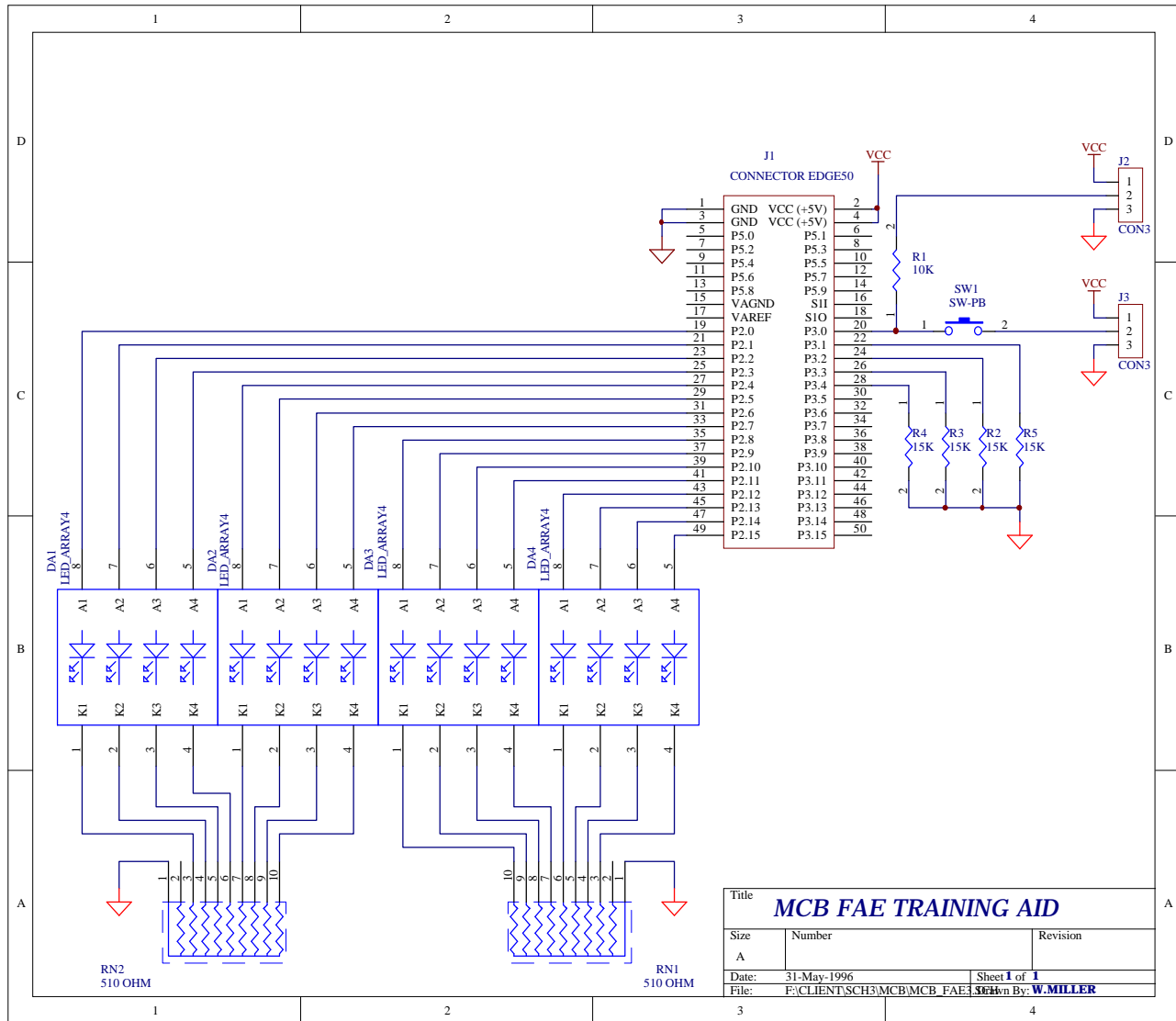

Rem.: Jumpers for Board ID are to be set between P2.1 / P3.1 (Bit 0, LSB), P2.2 / P3.2 (Bit 1), P2.3 / P3.3 (Bit 2) and P2.4/P3.4 (Bit 3, MSB). When P2.1 through P2.4 are set to log. '1', reading the input levels of P3.1 through P3.4 results in log. '1' for positions with jumper and log. '0' without jumper. Additionally, there have jumpers to be set on the CON3 connectors so that pushing the button results in a H/L or L/H transition at P3.0 .