

TOLERANCE UNLESS SPECIFIED =

.XXX= +/- .005

.XX= +/- .015

FRACTIONS= +/- .032

10-2000.DC2

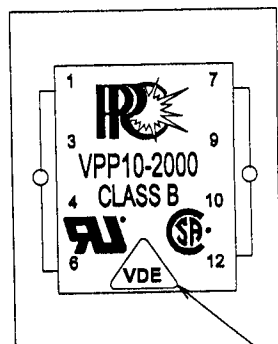

1.60 REF

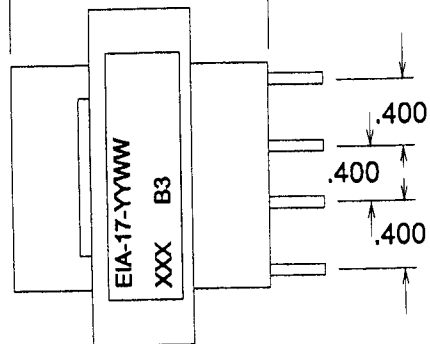

1.875 REF

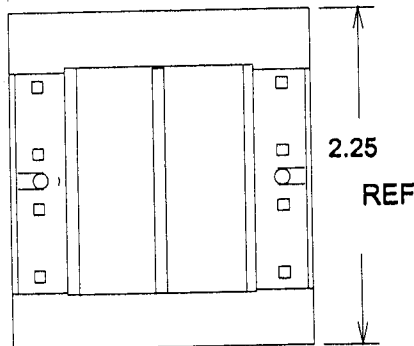

1.500

MTG

ALL MANUFACTURING SITES USE THIS MARK

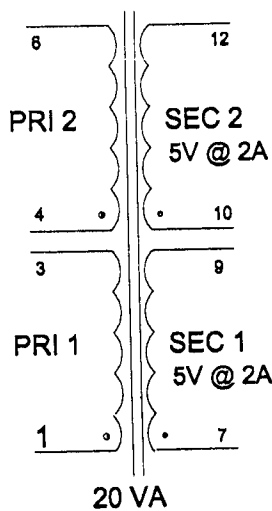

115/230V
50/60 HZ

PC PINS .036 SQ

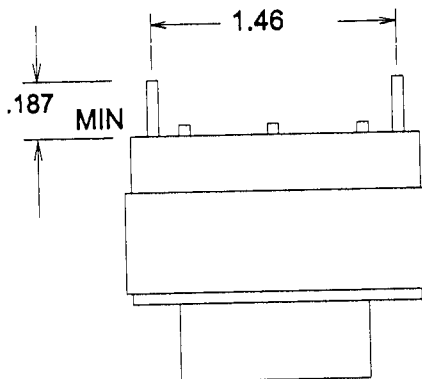

PRODUCTION TESTS

URNS RATIO = 100%

DC RESISTANCE IN OHMS	1-3 =	77 NOM
	4-6 =	90 NOM
	7-9 =	0.20 NOM
	10-12 =	0.24 NOM

MAX EXCITATION CURRENT = 0.030 A

APPLY 230V 60HZ 1-6 (3+4)

PRI WDGS 114.5 TO 115.5 V

SEC WDGS 5.9 TO 6.35 V

HIPOT: 4000V P-S
4000V P,S, TO CORE
600V P-P, S-S

IMPREGNATION NOTES: PREHEAT 2 HRS
PINS TO BE FREE OF IMPREGNATION.

FINAL ASSEMBLY NOTES

METHOD 1 X 1
LEAVE OFF LAST "I" PCS

MARKING SEE LABEL DETAIL ABOVE
APPLY PART NO. LABEL AFTER IMPREGNATION



PART NO. : VPP10-2000