

[www.DataSheet4U.com](http://www.DataSheet4U.com)

# SYM53C876/876E PCI-Dual Channel SCSI Multi-Function Controller

**Data Manual**  
**Version 2.0**



T76972I  
1197-1MH

[www.DataSheet4U.com](http://www.DataSheet4U.com)

---

The products described in this publication are products of Symbios Logic Inc.

SDMS and SCRIPTS are trademarks, and TolerANT is a registered trademark, of Symbios Logic Inc.

Ultra SCSI is the term used by the SCSI Trade Association (STA) to describe Fast-20 SCSI, as documented in the SCSI-3 Fast-20 Parallel Interface standard, X3.277-199X.

It is the policy of Symbios Logic to improve products as new technology, components, software, and firmware become available. Symbios Logic, therefore, reserves the right to change specifications without notice.

The products in this manual are not intended for use in life-support appliances, devices, or systems. Use of these products in such applications without the written consent of the appropriate Symbios Logic officer is prohibited

Copyright © 1996  
By Symbios Logic Inc.  
All Rights Reserved  
Printed in U.S.A.

We use comments from our readers to improve Symbios Logic product literature. Please e-mail any comments regarding technical documentation to [pubs@symbios.com](mailto:pubs@symbios.com).

---

# Preface

This manual assumes some prior knowledge of current and proposed SCSI, and PCI standards. For background information, please contact:

## **ANSI**

11 West 42nd Street  
New York, NY 10036  
(212) 642-4900  
Ask for document number X3.131-199X (SCSI-2)

## **Global Engineering Documents**

15 Inverness Way East  
Englewood, CO 80112  
(800) 854-7179 or (303) 397-7956 (outside U.S.) FAX (303) 397-2740  
Ask for document number X3.131-1994 (SCSI-2) or X3.253 (*SCSI-3 Parallel Interface*)

## **ENDL Publications**

14426 Black Walnut Court  
Saratoga, CA 95070  
(408) 867-6642  
Document names: *SCSI Bench Reference*, *SCSI Encyclopedia*, *SCSI Tutor*

## **Prentice Hall**

113 Sylvan Avenue  
Englewood Cliffs, NJ 07632  
(800) 947-7700  
Ask for document number ISBN 0-13-796855-8, *SCSI: Understanding the Small Computer System Interface*

## **Symbios Logic Electronic Bulletin Board**

(719)533-7235

## **SCSI Electronic Bulletin Board**

(719) 533-7950

## **Symbios Logic World Wide Web Home Page**

[www.symbios.com/t10](http://www.symbios.com/t10)

## **Symbios Logic Internet Anonymous FTP Site**

[ftp.symbios.com](ftp://symbios.com) (204.131.200.1)  
Directory: /pub/symchips/scsi

## **PCI Special Interest Group**

2575 N. E. Katherine  
Hillsboro, OR 97214  
(800) 433-5177; (503) 693-6232 (International); FAX (503) 693-8344

## **SYM53C8XX Family Programming Guide**

---

## Revision Record

---

<b>Page No.</b>	<b>Date</b>	<b>Remarks</b>
All	9/96	Preliminary Data Manual - Revision 1.0
All	11/97	Revised Data Manual - Revision 2.0

---



---

# Contents

Preface ..... i  
 Revision Record ..... ii  
 Contents ..... iii

**Chapter 1**

Introduction

General Description ..... 1-1  
 Wide Ultra SCSI Benefits ..... 1-4  
     SCSI TolerANT Technology ..... 1-4  
 SYM53C876 Benefits ..... 1-5  
     PCI Performance ..... 1-5  
     SCSI Performance ..... 1-5  
     Testability ..... 1-6  
     Integration ..... 1-6  
     Reliability ..... 1-6

**Chapter 2**

Functional Description

PCI Functional Description ..... 2-2  
     PCI Addressing ..... 2-2  
     PCI Bus Commands and Functions Supported ..... 2-3  
     Internal Arbiter ..... 2-7  
     PCI Cache Mode ..... 2-7  
 SCSI Functional Description ..... 2-9  
     Two SCSI Controllers ..... 2-9  
     SCRIPTS Processor ..... 2-9  
     JTAG Boundary Scan Testing ..... 2-11  
     SCSI Loopback Mode ..... 2-11  
     Parity Options ..... 2-11  
     DMA FIFO ..... 2-14  
     SCSI Bus Interface ..... 2-17  
     Synchronous Operation ..... 2-20  
     Designing a Wide Ultra SCSI System ..... 2-22  
     Interrupt Handling ..... 2-22  
     Chained Block Moves ..... 2-26  
 Parallel ROM Interface ..... 2-30  
 Serial EEPROM Interface ..... 2-31

Mode A Operation	2-31
Mode B Operation	2-32
Mode C Operation	2-32
Mode D Operation	2-33
Power Management	2-34
Power State D0	2-34
Power State D1	2-34
Power State D2	2-34
Power State D3	2-34

**Chapter 3**

Signal Descriptions

PCI Interface Pins	3-5
System Pins	3-5
Address/Data Pins	3-6
Interface Control Pins	3-7
Arbitration Pins	3-8
Error Recording Pins	3-8
PCI Interrupt Pins	3-9
GPIO Interface Pins	3-10
SCSI Interface Pins	3-11
Differential Control Pins	3-13
ROM/Flash Interface Pins	3-16
Test Pins	3-17
Power and Ground Pins	3-20
Isolated Power Supplies	3-20
MAD Bus Programming	3-21

**Chapter 4**

Registers

PCI Configuration Registers	4-1
SCSI Function A, AD(10-8) = 000 binary	4-1
SCSI Function B, AD(10-8) = 001 binary	4-1
Register 00h	
Vendor ID	
Read Only	4-2
Register 02h	
Device ID	
Read Only	4-3
Register 04h	
Command	
Read/Write	4-3

Register 06h	
Status	
Read/Write .....	4-4
Register 08h	
Revision ID	
Read Only .....	4-5
Register 09h	
Class Code	
Read Only .....	4-6
Register 0Ch	
Cache Line Size	
Read/Write .....	4-6
Register 0Dh	
Latency Timer	
Read/Write .....	4-7
Register 0Eh	
Header Type	
Read Only .....	4-7
Register 0Fh	
BIST	
Read Only .....	4-8
Register 10h	
Base Address Zero (I/O)	
Read/Write .....	4-8
Register 14h	
Base Address One (Memory)	
Read/Write .....	4-9
Register 18h	
Base Address Two (Memory)	
Read/Write .....	4-9
Register 2Ch	
Subsystem Vendor ID	
Read Only .....	4-10
Register 2Eh	
Subsystem ID	
Read Only .....	4-10
Register 30h	
Expansion ROM Base Address	
Read/Write .....	4-11
Register 34h	
Capabilities Pointer	
Read Only .....	4-11
Register 3Ch	
Interrupt Line	
Read/Write .....	4-12
Register 3Dh	

Interrupt Pin	
Read Only .....	4-12
Register 3Eh	
Min_Gnt	
Read Only .....	4-13
Register 3Fh	
Max_Lat	
Read Only .....	4-13
Register 40h	
Capability ID	
Read Only .....	4-14
Register 41h	
Next Item Pointer	
Read Only .....	4-14
Register 42h	
Power Management Capabilities	
Read Only .....	4-15
Register 44h	
Power Management Control/Status	
Read/Write .....	4-15
Register 46h	
PMCSR BSE	
Read Only .....	4-16
Register 47h	
Data	
Read Only .....	4-16
SCSI Registers .....	4-16
Register 00h	
SCSI Control Zero (SCNTL0)	
Read/Write .....	4-20
Register 01h	
SCSI Control One (SCNTL1)	
Read/Write .....	4-22
Register 02h	
SCSI Control Two (SCNTL2)	
Read/Write .....	4-24
Register 03h	
SCSI Control Three (SCNTL3)	
Read/Write .....	4-25
Register 04h	
SCSI Chip ID (SCID)	
Read/Write .....	4-26

Register 05h	
SCSI Transfer (SXFER)	
Read/Write .....	4-27
Register 06h	
SCSI Destination ID (SDID)	
Read/Write .....	4-28
Register 07h	
General Purpose (GPREG)	
Read/Write .....	4-29
Register 08h	
SCSI First Byte Received (SFBR)	
Read/Write .....	4-29
Register 09h	
SCSI Output Control Latch (SOCL)	
Read/Write .....	4-30
Register 0Ah	
SCSI Selector ID (SSID)	
Read Only .....	4-30
Register 0Bh	
SCSI Bus Control Lines (SBCL)	
Read Only .....	4-31
Register 0Ch	
DMA Status (DSTAT)	
Read Only .....	4-31
Register 0Dh	
SCSI Status Zero (SSTAT0)	
Read Only .....	4-33
Register 0Eh	
SCSI Status One (SSTAT1)	
Read Only .....	4-34
Register 0Fh	
SCSI Status Two (SSTAT2)	
Read Only .....	4-35
Registers 10h-13h	
Data Structure Address (DSA)	
Read/Write .....	4-36
Register 14h	
Interrupt Status (ISTAT)	
Read/Write .....	4-36
Register 18h	
Chip Test Zero (CTEST0)	
Read/Write .....	4-38
Register 19h	
Chip Test One (CTEST1)	
Read Only .....	4-39
Register 1Ah	
Chip Test Two (CTEST2)	

Read Only .....	4-39
Register 1Bh	
Chip Test Three (CTEST3)	
Read/Write .....	4-40
Registers 1Ch-1Fh	
Temporary (TEMP)	
Read/Write .....	4-41
Register 20h	
DMA FIFO (DFIFO)	
Read/Write .....	4-42
Register 21h	
Chip Test Four (CTEST4)	
Read/Write .....	4-42
Register 22h	
Chip Test Five (CTEST5)	
Read/Write .....	4-43
Register 23h	
Chip Test Six (CTEST6)	
Read/Write .....	4-44
Registers 24h-26h	
DMA Byte Counter (DBC)	
Read/Write .....	4-45
Register 27h	
DMA Command (DCMD)	
Read/Write .....	4-45
Registers 28h-2Bh	
DMA Next Address (DNAD)	
Read/Write .....	4-46
Registers 2Ch-2Fh	
DMA SCRIPTS Pointer (DSP)	
Read/Write .....	4-46
Registers 30h-33h	
DMA SCRIPTS Pointer Save (DSPS)	
Read/Write .....	4-47
Registers 34h	
Scratch Register A (SCRATCHA)	
Read/Write .....	4-47
Register 38h	
DMA Mode (DMODE)	
Read/Write .....	4-48
Register 39h	
DMA Interrupt Enable (DIEN)	
Read/Write .....	4-49
Register 3Ah	
Scratch Byte Register (SBR)	
Read/Write .....	4-50

Register 3Bh	
DMA Control (DCNTL)	
Read/Write . . . . .	4-51
Register 3Ch-3Fh	
Adder Sum Output (ADDER)	
Read Only . . . . .	4-52
Register 40h	
SCSI Interrupt Enable Zero (SIEN0)	
Read/Write . . . . .	4-53
Register 41h	
SCSI Interrupt Enable One (SIEN1)	
Read/Write . . . . .	4-54
Register 42h	
SCSI Interrupt Status Zero (SIST0)	
Read Only . . . . .	4-55
Register 43h	
SCSI Interrupt Status One (SIST1)	
Read Only . . . . .	4-57
Register 44h	
SCSI Longitudinal Parity (SLPAR)	
Read/Write . . . . .	4-58
Register 45h	
SCSI Wide Residue (SWIDE)	
Read/Write . . . . .	4-59
Register 46h	
Memory Access Control (MACNTL)	
Read/Write . . . . .	4-59
Register 47h	
General Purpose Pin Control (GPCNTL)	
Read/Write . . . . .	4-60
Register 48h	
SCSI Timer Zero (STIME0)	
Read/Write . . . . .	4-60
Register 49h	
SCSI Timer One (STIME1)	
Read/Write . . . . .	4-61
Register 4Ah	
Response ID Zero (RESPID0)	
Read/Write . . . . .	4-62
Register 4Bh	
Response ID One (RESPID1)	
Read/Write . . . . .	4-62
Register 4Ch	
SCSI Test Zero (STEST0)	
Read Only . . . . .	4-63

Register 4Dh  
 SCSI Test One (STEST1)  
 Read/Write ..... 4-64

Register 4Eh  
 SCSI Test Two (STEST2)  
 Read/Write ..... 4-65

Register 4Fh  
 SCSI Test Three (STEST3)  
 Read/Write ..... 4-66

Register 50h-51h  
 SCSI Input Data Latch (SIDL)  
 Read Only ..... 4-68

Registers 54h-55h  
 SCSI Output Data Latch (SODL)  
 Read/Write ..... 4-68

Registers 58h-59h  
 SCSI Bus Data Lines (SBDL)  
 Read Only ..... 4-69

Registers 5Ch-5Fh  
 Scratch Register B (SCRATCHB)  
 Read/Write ..... 4-69

Registers 60h-7Fh  
 Scratch Registers C-J  
 (SCRATCHC-SCRATCHJ)  
 Read/Write ..... 4-70

**Chapter 5**

SCSI SCRIPTS Instruction Set

SCSI SCRIPTS ..... 5-1  
 Sample Operation ..... 5-2

Block Move Instructions ..... 5-3  
 First Dword ..... 5-3  
 Second Dword ..... 5-7

I/O Instructions ..... 5-7  
 First Dword ..... 5-7  
 Second Dword ..... 5-12

Read/Write Instructions ..... 5-12  
 First Dword ..... 5-12  
 Second Dword ..... 5-13  
 Read-Modify-Write Cycles ..... 5-14  
 Move to/from SFBR Cycles ..... 5-14

Transfer Control Instructions ..... 5-15  
 First Dword ..... 5-15  
 Second Dword ..... 5-20



Memory Move Instructions ..... 5-20  
     Read/Write System Memory from a Script ..... 5-21  
     Second Dword ..... 5-21  
     Third Dword ..... 5-21  
 Load and Store Instructions ..... 5-22  
     First Dword ..... 5-23  
     Second Dword ..... 5-23

**Chapter 6**

Electrical Characteristics

DC Characteristics ..... 6-1  
 3.3 Volt PCI DC Characteristics ..... 6-7  
 TolerANT Technology Electrical Characteristics ..... 6-9  
 AC Characteristics ..... 6-12  
     PCI and External Memory Interface Timings ..... 6-15  
     PCI and External Memory Interface Timings ..... 6-52  
     SCSI Interface Timings ..... 6-53

**Appendix A**

Register Summary

Configuration Registers ..... A-1  
     Register 00h  
         Vendor ID  
         Read Only ..... A-1  
     Register 02h  
         Device ID  
         Read Only ..... A-1  
     Register 04h  
         Command  
         Read/Write ..... A-1  
     Register 06h  
         Status  
         Read/Write ..... A-1  
     Register 08h  
         Revision ID  
         Read Only ..... A-1  
     Register 09h  
         Class Code  
         Read Only ..... A-1  
     Register 0Ch  
         Cache Line Size  
         Read/Write ..... A-2

Register 0Dh	
Latency Timer	
Read/Write .....	A-2
Register 0Eh	
Header Type	
Read Only .....	A-2
Register 0Fh	
BIST	
Read Only .....	A-2
Register 10h	
Base Address Zero (I/O)	
Read/Write .....	A-2
Register 14h	
Base Address One (Memory)	
Read/Write .....	A-2
Register 18h	
Base Address Two (Memory)	
Read/Write .....	A-2
Register 2Ch	
Subsystem Vendor ID	
Read Only .....	A-2
Register 2Eh	
Subsystem ID	
Read Only .....	A-2
Register 30h	
Expansion ROM Base Address	
Read/Write .....	A-2
Register 34h	
Capabilities Pointer	
Read Only .....	A-2
Register 3Ch	
Interrupt Line	
Read/Write .....	A-3
Register 3Dh	
Interrupt Pin	
Read Only .....	A-3
Register 3Eh	
Min_Gnt	
Read Only .....	A-3
Register 3Fh	
Max_Lat	
Read Only .....	A-3
Register 40h	
Capability ID	
Read Only .....	A-3

Register 41h	
Next Item Pointer	
<i>Read Only</i> .....	A-3
Register 42h	
Power Management Capabilities	
<i>Read Only</i> .....	A-3
Register 44h	
Power Management Control/Status	
<i>Read/Write</i> .....	A-3
Register 46h	
PMCSR BSE	
<i>Read Only</i> .....	A-3
SCSI Registers .....	A-4
Register 00h	
SCSI Control Zero (SCNTL0)	
<i>Read/Write</i> .....	A-4
Register 01h	
SCSI Control One (SCNTL1)	
<i>Read/Write</i> .....	A-4
Register 02h	
SCSI Control Two (SCNTL2)	
<i>Read/Write</i> .....	A-4
Register 03h	
SCSI Control Three (SCNTL3)	
<i>Read/Write</i> .....	A-4
Register 04h	
SCSI Chip ID (SCID)	
<i>Read/Write</i> .....	A-5
Register 05h	
SCSI Transfer (SXFER)	
<i>Read/Write</i> .....	A-5
Register 06h	
SCSI Destination ID (SDID)	
<i>Read/Write</i> .....	A-5
Register 07h	
General Purpose (GPREG)	
<i>Read/Write</i> .....	A-5
Register 08h	
SCSI First Byte Received (SFBR)	
<i>Read/Write</i> .....	A-5
Register 09h	
SCSI Output Control Latch (SOCL)	
<i>Read/Write</i> .....	A-5
Register 0Ah	
SCSI Selector ID (SSID)	
<i>Read Only</i> .....	A-5

Register 0Bh	
SCSI Bus Control Lines (SBCL)	
Read Only .....	A-5
Register 0Ch	
DMA Status (DSTAT)	
Read Only .....	A-6
Register 0Dh	
SCSI Status Zero (SSTAT0)	
Read Only .....	A-6
Register 0Eh	
SCSI Status One (SSTAT1)	
Read Only .....	A-6
Register 0Fh	
SCSI Status Two (SSTAT2)	
Read Only .....	A-6
Registers 10h-13h	
Data Structure Address (DSA)	
Read/Write .....	A-6
Register 14h	
Interrupt Status (ISTAT)	
Read/Write .....	A-6
Register 18h	
Chip Test Zero (CTEST0)	
Read/Write .....	A-6
Register 19h	
Chip Test One (CTEST1)	
Read Only .....	A-7
Register 1Ah	
Chip Test Two (CTEST2)	
Read Only .....	A-7
Register 1Bh	
Chip Test Three (CTEST3)	
Read/Write .....	A-7
Registers 1Ch-1Fh	
Temporary (TEMP)	
Read/Write .....	A-7
Register 20h	
DMA FIFO (DFIFO)	
Read/Write .....	A-7
Register 21h	
Chip Test Four (CTEST4)	
Read/Write .....	A-7
Register 22h	
Chip Test Five (CTEST5)	
Read/Write .....	A-7

Register 23h  
 Chip Test Six (CTEST6)  
 Read/Write ..... A-7

Registers 24h-26h  
 DMA Byte Counter (DBC)  
 Read/Write ..... A-8

Register 27h  
 DMA Command (DCMD)  
 Read/Write ..... A-8

Registers 28h-2Bh  
 DMA Next Address (DNAD)  
 Read/Write ..... A-8

Registers 2Ch-2Fh  
 DMA SCRIPTS Pointer (DSP)  
 Read/Write ..... A-8

Registers 30h-33h  
 DMA SCRIPTS Pointer Save (DSPS)  
 Read/Write ..... A-8

Registers 34h  
 Scratch Register A (SCRATCHA)  
 Read/Write ..... A-8

Register 38h  
 DMA Mode (DMODE)  
 Read/Write ..... A-8

Register 39h  
 DMA Interrupt Enable (DIEN)  
 Read/Write ..... A-8

Register 3Ah  
 Scratch Byte Register (SBR)  
 Read/Write ..... A-8

Register 3Bh  
 DMA Control (DCNTL)  
 Read/Write ..... A-8

Register 3Ch-3Fh  
 Adder Sum Output (ADDER)  
 Read Only ..... A-8

Register 40h  
 SCSI Interrupt Enable Zero (SIEN0)  
 Read/Write ..... A-9

Register 41h  
 SCSI Interrupt Enable One (SIEN1)  
 Read/Write ..... A-9

Register 42h  
 SCSI Interrupt Status Zero (SIST0)  
 Read Only ..... A-9

Register 43h	
SCSI Interrupt Status One (SIST1)	
Read Only .....	A-9
Register 44h	
SCSI Longitudinal Parity (SLPAR)	
Read/Write .....	A-9
Register 45h	
SCSI Wide Residue (SWIDE)	
Read/Write .....	A-9
Register 46h	
Memory Access Control (MACNTL)	
Read/Write .....	A-9
Register 47h	
General Purpose Pin Control (GPCNTL)	
Read/Write .....	A-9
Register 48h	
SCSI Timer Zero (STIME0)	
Read/Write .....	A-10
Register 49h	
SCSI Timer One (STIME1)	
Read/Write .....	A-10
Register 4Ah	
Response ID Zero (RESPID0)	
Read/Write .....	A-10
Register 4Bh	
Response ID One (RESPID1)	
Read/Write .....	A-10
Register 4Ch	
SCSI Test Zero (STEST0)	
Read Only .....	A-10
Register 4Dh	
SCSI Test One (STEST1)	
Read/Write .....	A-10
Register 4Eh	
SCSI Test Two (STEST2)	
Read/Write .....	A-10
Register 4Fh	
SCSI Test Three (STEST3)	
Read/Write .....	A-11
Register 50h-51h	
SCSI Input Data Latch (SIDL)	
Read Only .....	A-11
Registers 54h-55h	
SCSI Output Data Latch (SODL)	
Read/Write .....	A-11

Registers 58h-59h  
 SCSI Bus Data Lines (SBDL)  
 Read Only ..... A-11

Registers 5Ch-5Fh  
 Scratch Register B (SCRATCHB)  
 Read/Write ..... A-11

Registers 60h-7Fh  
 Scratch Registers C-J  
 (SCRATCHC-SCRATCHJ)  
 Read/Write ..... A-11

**Appendix B**

Mechanical Drawings

**Appendix C**

External Memory Interface Diagram Examples

Index ..... Index-1

Symbios Logic  
 Sales Locations ..... 1

For literature on any Symbios Logic product or service,  
 call our hotline toll-free  
 1-800-856-3093 ..... 1





## List of Tables

Table 2-1: PCI Bus Commands and Encoding Types.....	2-4
Table 2-2: Bits Used for Parity Control and Generation .....	2-12
Table 2-3: SCSI Parity Control .....	2-13
Table 2-4: SCSI Parity Errors and Interrupts .....	2-13
Table 2-5: Parallel ROM Support .....	2-30
Table 2-6: Mode A Serial EEPROM data format .....	2-31
Table 2-7: Mode C Serial EEPROM data format .....	2-32
Table 2-8: Power States .....	2-34
Table 3-1: PCI Interface Pins.....	3-5
Table 3-2: PCI Interface Pins .....	3-6
Table 3-3: PCI Interface Pins .....	3-7
Table 3-4: PCI Interface Pins .....	3-8
Table 3-5: PCI Interface Pins .....	3-8
Table 3-6: PCI Interrupt Pins .....	3-9
Table 3-7: GPIO Interface Pins .....	3-10
Table 3-8: SCSI Interface Pins .....	3-11
Table 3-9: Differential Control Pins .....	3-13
Table 3-10: ROM/Flash Interface Pins .....	3-16
Table 3-11: Test Pins .....	3-17
Table 3-12: Power and Ground Pins .....	3-20
Table 3-13: Decode of MAD pins .....	3-22
Table 4-1: PCI-to-SCSI Configuration Register Map.....	4-1
Table 4-2: SCSI Operating Register Addresses and Descriptions .....	4-17

List of Tables .....

Table 4-3: SYM53C876 SCSI Register Address Map .....	4-18
Table 4-4: Examples of Synchronous Transfer Periods for SCSI-1 Transfer Rates 4-27	
Table 4-5: Example Transfer periods for Fast SCSI and Wide Ultra SCSI transfer rates 4-27	
Table 5-1: Read/Write Instructions .....	5-14
Table 5-2: .....	5-23
Table 6-1: Absolute Maximum Stress Ratings .....	6-1
Table 6-2: Operating Conditions .....	6-1
Table 6-3: SCSI Signals .....	6-2
Table 6-4: SCSI Signals .....	6-2
Table 6-5: Input Signals .....	6-2
Table 6-6: Capacitance .....	6-3
Table 6-7: Output Signal - INTA/, INTB/ .....	6-3
Table 6-8: Output Signals - SDIR(15-0), SDIRP0/1, BSYDIR, SELDIR, RSTDIR, TGS, IGS, MAS/(1-0), MCE/, MOE/_TESTOUT, MWE/ .....	6-4
Table 6-9: Output Signal - REQ/ .....	6-4
Table 6-10: Output Signal - SERR/ .....	6-4
Table 6-11: Bidirectional Signals - AD(31-0), C_BE/(3-0), FRAME/, IRDY/, TRDY/, DEVSEL/, STOP/, PERR/, PAR .....	6-4
Table 6-12: Bidirectional Signals - GPIO0_FETCH/, GPIO1_MASTER/, GPIO2, GPIO3, GPIO4 .....	6-5
Table 6-13: Bidirectional Signals - MAD(7-0) .....	6-5
Table 6-14: Input Signals —TDI, TMS, TCK .....	6-6
Table 6-15: Output Signal — TDO .....	6-6
Table 6-16: Bidirectional Signals—AD(31-0), C_BE(3-0)/, FRAME/, IRDY/, TRDY/, DEVSEL/, STOP/, PERR/, PAR .....	6-7
Table 6-17: Input Signals—CLK, GNT/, IDSEL, RST/ .....	6-7
Table 6-18: Output Signals—INTA/, INTB, REQ/ .....	6-7
Table 6-19: Output Signal—SERR/ .....	6-8
Table 6-20: TolerANT Technology Electrical Characteristics .....	6-9
Table 6-21: Clock Timing .....	6-12
Table 6-22: Reset Input .....	6-12
Table 6-23: Interrupt Output .....	6-14

List of Tables .....

Table 6-24: Configuration Register Read .....	6-16
Table 6-25: Configuration Register Write .....	6-17
Table 6-26: Target Read, not from external memory .....	6-17
Table 6-27: Target Write, not from external memory .....	6-18
Table 6-28: Target Read, from external memory .....	6-19
Table 6-29: Target Write, from external memory .....	6-22
Table 6-30: Op Code Fetch, non-Burst .....	6-24
Table 6-31: Op Code Fetch, Burst .....	6-25
Table 6-32: Back to Back Read .....	6-27
Table 6-33: Back to Back Write .....	6-29
Table 6-34: Burst Read .....	6-32
Table 6-35: Burst Write .....	6-34
Table 6-36: Read Cycle, Normal/Fast Memory .....	6-36
Table 6-37: Write Cycle, Normal/Fast Memory .....	6-38
Table 6-38: Read Cycle, Slow MemoryL .....	6-44
Table 6-39: Write Cycle, Slow Memory .....	6-46
Table 6-40: Read Cycle, 16 KB ROM .....	6-48
Table 6-41: Write Cycle, 16 KB ROM .....	6-50
Table 6-42: SYM53C876 PCI and External Memory Interface Timings .....	6-52
Table 6-43: Initiator Asynchronous Send .....	6-53
Table 6-44: Initiator Asynchronous Receive .....	6-54
Table 6-45: Target Asynchronous Send .....	6-54
Table 6-46: Target Asynchronous Receive .....	6-55
Table 6-47: SCSI-1 transfers (Single-Ended, 5.0 MB/s) .....	6-55
Table 6-48: SCSI-2 Fast Transfers (10.0 MB/s (8-bit transfers) or 20.0 MB/s (16-bit transfers), 40 MHz clock) .....	6-57
Table 6-49: SCSI-2 Fast-20 Single-Ended Transfers (20.0 MB/s (8-bit transfers) or 40.0 MB/s (16-bit transfers), 80 MHz clock) with clock doubled internally ...	6-57

List of Tables . . . . .

## List of Figures

Figure 1-1: Typical SYM53C876 System Application .....	1-2
Figure 1-2: Typical SYM53C876 Board Application .....	1-3
Figure 2-1: SYM53C876 Block Diagram ..	2-2
Figure 2-2: Parity Checking/Generation .....	2-14
Figure 2-3: DMA FIFO Sections .....	2-14
Figure 2-4: SYM53C876 Host Interface SCSI Data Paths .....	2-16
Figure 2-5: SYM53C876 Differential Wiring Diagram .....	2-19
Figure 2-6: Regulated Termination .....	2-20
Figure 2-7: Determining the Synchronous Transfer Rate .....	2-22
Figure 2-8: Block Move and Chained Block Move Instructions .....	2-29
Figure 3-1: SYM53C876 208-Pin PQFP Diagram .....	3-1
Figure 3-2: SYM53C876 256-Ball BGA Diagram (top view) .....	3-2
Figure 3-3: SYM53C876 Functional Signal Grouping .....	3-3
Figure 5-1: SCRIPTS Overview .....	5-3
Figure 5-2: Block Move Instruction Register .....	5-5
Figure 5-3: I/O Instruction Register .....	5-9
Figure 5-4: Read/Write Instruction Register .....	5-13
Figure 5-5: Transfer Control Instruction .....	5-17
Figure 5-6: Memory Move Instructions .....	5-22
Figure 5-7: Load and Store Instruction Format .....	5-24
Figure 6-1: Rise and Fall Time Test Conditions.....	6-10
Figure 6-2: SCSI Input Filtering .....	6-10
Figure 6-3: Hysteresis of SCSI Receiver .....	6-10

List of Figures .....

Figure 6-4: Input Current as a Function of Input Voltage .....	6-11
Figure 6-5: Output Current as a Function of Output Voltage .....	6-11
Figure 6-6: Clock Timing .....	6-12
Figure 6-7: Reset Input .....	6-13
Figure 6-8: Interrupt Output .....	6-14
Figure 6-9: Configuration Register Read .....	6-16
Figure 6-10: Configuration Register Write .....	6-17
Figure 6-11: Target Read, not from external memory .....	6-18
Figure 6-12: Target Write, not from external memory .....	6-19
Figure 6-13: Target Read, from external memory .....	6-21
Figure 6-14: Target Write, from external memory .....	6-23
Figure 6-15: Op Code Fetch, non-Burst .....	6-25
Figure 6-16: Op Code Fetch, Burst .....	6-27
Figure 6-17: Back to Back Read .....	6-29
Figure 6-18: Back to Back Write .....	6-31
Figure 6-19: Burst Read .....	6-33
Figure 6-20: Burst Write .....	6-35
Figure 6-21: Read Cycle, Normal/Fast Memory .....	6-37
Figure 6-22: Write Cycle, Normal/Fast Memory .....	6-39
Figure 6-23: Read Cycle, Normal/Fast Memory .....	6-40
Figure 6-24: Write Cycle, Normal/Fast Memory .....	6-42
Figure 6-25: Read Cycle, Slow Memory .....	6-45
Figure 6-26: Write Cycle, Slow Memory .....	6-47
Figure 6-27: Read Cycle, 16 KB ROM .....	6-49
Figure 6-28: Write Cycle, 16 KB ROM .....	6-51
Figure 6-29: Initiator Asynchronous Send .....	6-53
Figure 6-30: Initiator Asynchronous Receive .....	6-54
Figure 6-31: Target Asynchronous Send .....	6-54
Figure 6-32: Target Asynchronous Receive .....	6-55
Figure 6-33: Initiator and Target Synchronous Transfers .....	6-55
Figure B-1: SYM53C876 208-Pin PQFP Mechanical Drawing.....	B-2
Figure B-2: SYM53C876 256-Bump PBGA Mechanical Drawing .....	B-3

List of Figures .....

Figure C-1: 16 K Interface With 200 ns Memory ..... C-1  
Figure C-2: 64 K Interface with 150 ns Memory .....C-2  
Figure C-3: 256 K Interface With 150 ns Memory .....C-3  
Figure C-4: 512 K Interface With 150 ns Memory .....C-4

List of Figures . . . . .



## Chapter 1

# Introduction

## General Description

This manual combines information for the SYM53C876 and SYM53C876E, which are a PCI-Dual SCSI controllers. The SYM53C876E is a minor modification of the existing SYM53C876 product. It has all of the functionality of the SYM53C876 with the addition of features to enable it to comply with Microsoft's PC 97 Hardware Design Guide. Specifically, the SYM53C876E has a Power Management Support enhancement. Because there are only slight differences between them, the SYM53C876 and SYM53C876E are referred to as SYM53C876 throughout this data manual. Only the new enhancements are referred to as SYM53C876E.

The SYM53C876 PCI-Dual Channel SCSI Multifunction Controller is a PCI 2.1 compliant device. It implements two SYM53C875 PCI-to-Ultra SCSI controllers on a single chip. The SYM53C876 presents only one load to the PCI bus, and it uses one REQ/ - GNT/ signal pair in arbitration for PCI bus mastership.

Two packaging options are available. The 208-pin PQFP provides a differential/single-ended SCSI interface on SCSI Function A and a single-ended interface on SCSI Function B. The 256-bump BGA provides a differential/single-ended interface on both SCSI Function A and SCSI Function B.

The SYM53C876 provides a local memory bus for storage of the device's ROM BIOS in flash memory or standard EPROMs. The SYM53C876 supports programming of local FLASH memory for updates to BIOS or SCRIPTS programs.

The SYM53C876 reduces the requirement for system BIOS support and PCI bus bandwidth. It also supports the Wide Ultra SCSI standard. The SYM53C876 performs Wide Ultra SCSI transfers or Fast SCSI transfers, and it improves performance by optimizing PCI bus utilization. Figure 1-1 illustrates a typical SYM53C876 system and Figure 1-2 illustrates a typical SYM53C876 board application.

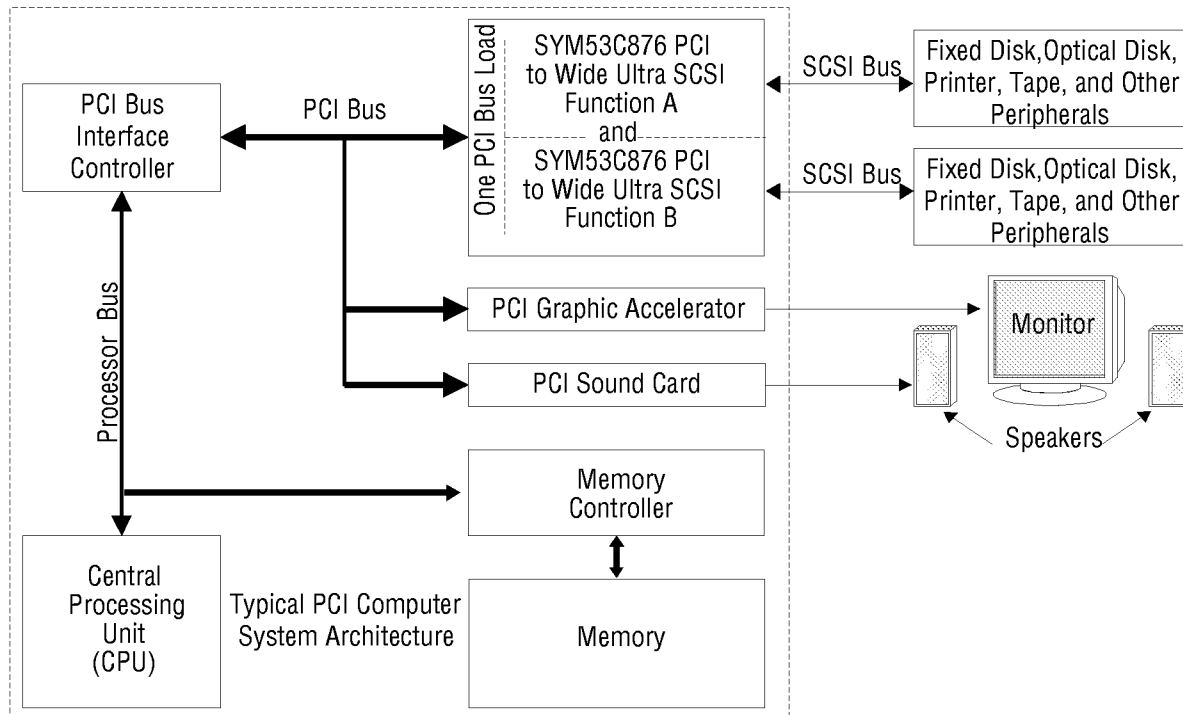

**Figure 1-1: Typical SYM53C876 System Application**

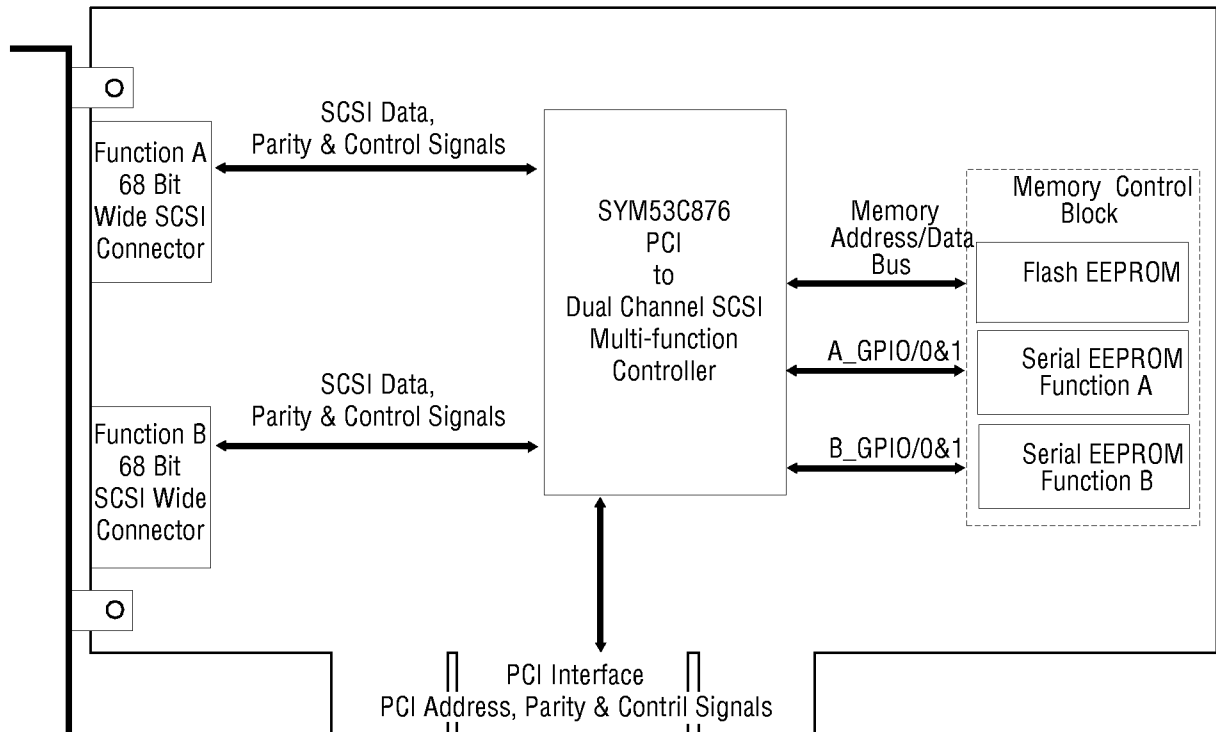

**Figure 1-2: Typical SYM53C876 Board Application**

The SYM53C876 integrates a high-performance SCSI core, a PCI bus master DMA core, and the Symbios Logic SCSI SCRIPTS™ processor to meet the flexibility requirements of SCSI, Fast SCSI, and Wide Ultra SCSI standards. It is designed to implement multi-threaded I/O algorithms with a minimum of processor intervention, solving the protocol overhead problems of previous intelligent and non-intelligent controller designs.

The SYM53C876 is fully supported by the Symbios Logic SCSI Device Management System (SDMS™), a software package that supports the Advanced SCSI Protocol Interface (ASPI). SDMS provides BIOS and driver support for hard disk, tape, removable media products, and CD-ROM under the major PC operating systems.

In addition, Symbios Logic provides a SYMlicity™ I<sub>2</sub>O Hardware Device Module for the SYM53C876 to support the device in I<sub>2</sub>O-ready systems. The SYMlicity I<sub>2</sub>O architecture is compliant with the I<sub>2</sub>O specification. I<sub>2</sub>O is a

split driver architecture that increases system efficiency by transferring I/O-intensive processing tasks from the host CPU to intelligent peripheral platforms.

---

## Wide Ultra SCSI Benefits

Wide Ultra SCSI is an extension of the SCSI-3 family of standards that expands the bandwidth of the SCSI bus and allows faster synchronous SCSI transfer rates. When enabled, Wide Ultra SCSI performs 40 mega-transfers per second during an I/O operation, which results in approximately doubling the synchronous transfer rates of Fast SCSI. The SYM53C876 can perform Ultra SCSI synchronous transfers at 20 MB/s. It can also perform Wide Ultra SCSI transfers at 40 MB/s. This advantage is most noticeable in heavily loaded systems or large-block size applications such as video on-demand and image processing.

Another advantage of Wide Ultra SCSI is that it significantly improves SCSI bandwidth while preserving existing hardware and software investments. The SYM53C876 is compatible with all existing SYM53C875 software.

---

### SCSI TolerANT Technology

The SYM53C876 features TolerANT® technology, which includes active negation on the SCSI drivers and input signal filtering on the SCSI receivers. Through active negation, the SCSI Request, Acknowledge, Data, and Parity signals are actively driven high rather than passively pulled up by terminators. Active negation is enabled by setting bit 7 in the STEST3 register.

TolerANT receiver technology improves data integrity in unreliable cabling environments, where other devices are subject to data corruption. TolerANT receivers filter the SCSI bus signals to eliminate unwanted transitions, without the long signal delay associated with RC-type input filters. This improved driver and receiver technology helps eliminate double clocking of data, the single biggest reliability issue with SCSI

operations. TolerANT input signal filtering is a built-in feature of the SYM53C876 and all Sym-bios Logic Fast SCSI and Ultra SCSI devices.

The benefits of TolerANT include increased immunity to noise on the deasserting signal edge, better performance due to balanced duty cycles, and improved Fast SCSI transfer rates. In addition, TolerANT SCSI devices do not cause glitches on the SCSI bus at power up or power down, so other devices on the bus are also protected from data corruption. TolerANT is compatible with both the Alternative One and Alternative Two termination schemes proposed by the American National Standards Institute (ANSI).

---

## SYM53C876 Benefits

---

### PCI Performance

- PCI 2.1 compliant
- True Multi-function device as defined in PCI 2.1 specification – presents only one load to the PCI bus
- Supports 32-bit word data bursts with variable burst lengths of 2, 4, 8, 16, 32, 64 or 128 dwords across the PCI bus
- Prefetches up to 8 dwords of SCSI SCRIPTS
- Bursts SCSI SCRIPTS op code fetches across the PCI bus
- Performs zero wait-state bus master data bursts at 132 MB/s (@ 33 MHz)
- Supports PCI Cache Line Size register
- Supports PCI Write and Invalidate, Read Line, and Read Multiple commands
- Complies with PCI Bus Power Management Specification (SYM53C876E) Revision 1.0.

---

### SCSI Performance

- Includes 4KB internal RAM on each channel for SCRIPTS instruction storage
- Wide Ultra SCSI Single-Ended Interface
- Performs Wide Ultra SCSI synchronous transfers as fast as 40 MB/s
- 536-byte DMA FIFO for more effective PCI and SCSI bus utilization
- SCSI synchronous offset of 16 levels
- Supports variable block size and scatter/gather data transfers

- Minimizes SCSI I/O start latency
- Performs complex bus sequences without interrupts, including restore data pointers
- Reduces ISR overhead through a unique interrupt status reporting method

- Load and Store SCRIPTS instruction increases performance of data transfers to and from chip registers
- Supports target disconnect and later reconnect with no interrupt to the system processor
- Supports multi-threaded I/O algorithms in SCSI SCRIPTS with fast I/O context switching
- Expanded Register Move instruction support
- Software (drivers and SCRIPTS) compatible with SYM53C875
- Integrated clock doubler enables Ultra SCSI with 40 MHz SCSI clock input
- impedance mismatches
- Controlled bus assertion times (reduces EMI, improves reliability, and eases FCC certification)
- Latch-up protection greater than 150 mA
- Voltage feed through protection (minimum leakage current through SCSI pads)
- Power and ground isolation of I/O pads and internal chip logic
- TolerANT technology with:
  - Active negation of SCSI Data, Parity, Request, and Acknowledge signals for improved Fast SCSI transfer rates.
  - Input signal filtering on SCSI receivers; improves data integrity, even in noisy cabling environments.

---

## Testability

- Access to all SCSI signals through programmed I/O
- SCSI loopback diagnostics
- SCSI bus signal continuity checking
- Single-step mode operation
- Test mode (AND tree) to check pin continuity to the board

---

## Integration

- Dual Channel SCSI Multi-function Controller
- 3.3 V/5 V PCI interface
- Full 32-bit PCI DMA bus master
- Can be used as a third-party PCI bus DMA controller by using Memory to Memory Move instructions
- High performance SCSI core
- Integrated SCSI SCRIPTS processor

---

## Reliability

- 2 KV ESD protection on SCSI signals
- Typical 300 mV SCSI bus hysteresis
- Protection against bus reflections due to

## Chapter 2

# Functional Description

The SYM53C876 is a multi-function device composed of the following modules:

- PCI Interface
- Two independent PCI-to-Wide Ultra SCSI Controllers
- ROM/Flash Memory Controller
- Serial EEPROM Controller

Figure 2-1 illustrates the relationship between these modules.

Chapter 2 is divided into the following sections:

- PCI Functional Description
- SCSI Functional Description
- Parallel ROM Interface
- Serial EEPROM Interface
- PCI Bus Power Management Support (SYM53C876E)

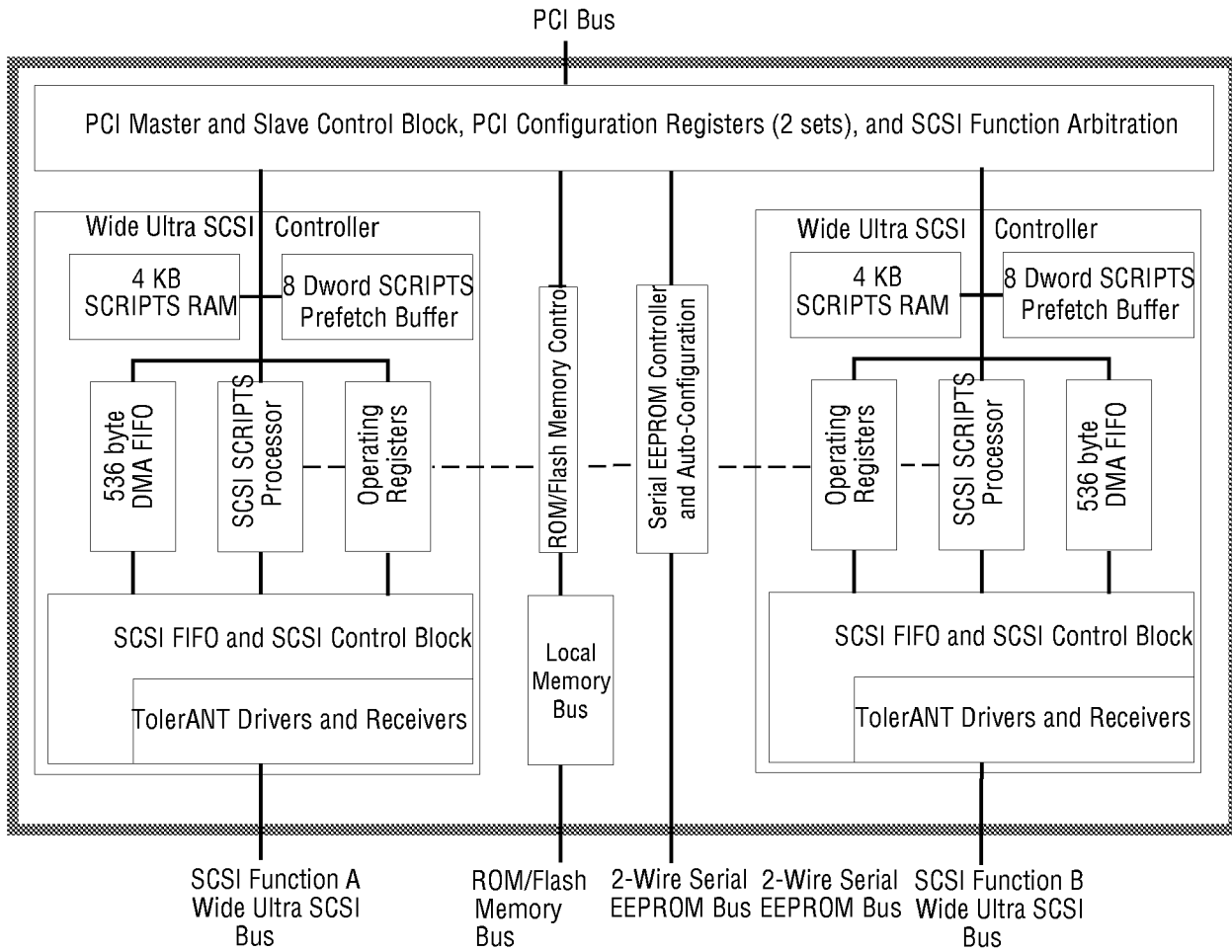

**Figure 2-1: SYM53C876 Block Diagram**

## PCI Functional Description

The SYM53C876 implements two PCI-to-Wide Ultra SCSI controllers in a single package. This configuration presents only one load to the PCI bus and uses one REQ/ - GNT/ pair to arbitrate for PCI bus mastership. However, separate interrupt signals are generated for SCSI Function A and SCSI Function B.

## PCI Addressing

There are three physical PCI-defined address spaces:

- Configuration space for SCSI
- I/O space
- Memory space



## Configuration Space

Two independent sets of configuration space registers are defined, one set for each SCSI function. The Configuration registers are accessible only by system BIOS during PCI configuration cycles. Each configuration space is a contiguous 256 x 8-bit set of addresses. Decoding C\_BE/(3-0) determines if a PCI cycle is intended to access configuration register space. The IDSEL bus signal is a “chip select” that allows access to the configuration register space only. A configuration read/write cycle without IDSEL is ignored. The eight lower order addresses AD (7-0) are used to select a specific 8-bit register. Since the SYM53C876 is a PCI multi-function device, AD (10-8) decodes either SCSI Function A Configuration register (AD (10-8) = 000 binary) or SCSI Function B Configuration register (AD (10-8) = 001 binary). The host processor uses this configuration space to initialize the SYM53C876.

At initialization time, each PCI device is assigned a base address (in the case of the SYM53C876, the upper 24 bits of the address are selected) for memory accesses and I/O accesses. On every access, the SYM53C876 compares its assigned base addresses with the value on the Address/Data bus during the PCI address phase. If there is a match of the upper 24 bits, the access is for the SYM53C876 and the low order eight bits define the register to

access. A decode of C\_BE/ (3-0) determines which registers and what type of access is performed.

## I/O Space

PCI defines I/O space as a contiguous 32-bit I/O address that is shared by all system resources, including the SYM53C876. The Base Address Zero register determines which 256-byte I/O area this device occupies.

## Memory Space

PCI defines memory space as a contiguous 32-bit memory address that is shared by all system resources, including the SYM53C876. The Base Address One register determines which 256-byte memory area this device occupies. Each SCSI function uses a 4K SCRIPT RAM memory space. The Base Address Two register determines the 4 KB memory area that the SCRIPT RAM occupies.

---

## PCI Bus Commands and Functions Supported

Bus commands indicate to the target the type of transaction the master is requesting. Bus commands are encoded on the C\_BE/(3-0) lines during the address phase. PCI bus command encoding and types appear in Table 2-1.

**Table 2-1: PCI Bus Commands and Encoding Types**

<b>C_BE (3-0)</b>	<b>Command Type</b>	<b>Supported as Master</b>	<b>Supported as Slave</b>
0000	Interrupt Acknowledge	No	No
0001	Special Cycle	No	No
0010	I/O Read	Yes	Yes
0011	I/O Write	Yes	Yes
0100	Reserved	n/a	n/a
0101	Reserved	n/a	n/a
0110	Memory Read	Yes	Yes
0111	Memory Write	Yes	Yes
1000	Reserved	n/a	n/a
1001	Reserved	n/a	n/a
1010	Configuration Read	No	Yes
1011	Configuration Write	No	Yes
1100	Memory Read Multiple	Yes*	Yes (defaults to 0110)
1101	Dual Address Cycle	No	No
1110	Memory Read Line	Yes*	Yes (defaults to 0110)
1111	Memory Write and Invalidate	Yes**	Yes (defaults to 0111)

\* See the *DMODE* register.

\*\* See the *CTEST3* register

### Interrupt Acknowledge Command

The SYM53C876 does not respond to this command as a slave and it never generates this command as a master.

### Special Cycle Command

The SYM53C876 does not respond to this command as a slave and it never generates this command as a master.

### I/O Read Command

The I/O Read command is used to read data from an agent mapped in I/O address space. All 32 address bits are decoded.

### I/O Write Command

The I/O Write command is used to write data to an agent mapped in I/O address space. All 32 address bits are decoded.

### Reserved Commands

The SYM53C876 does not respond to reserved commands as a slave, and it never generates these commands as a master.

### Memory Read Command

The Memory Read command reads data from an agent mapped in the Memory Address Space. The target is free to do an anticipatory read for this command only if it can guarantee that such a read has no side effects.

### Memory Write Command

The Memory Write command writes data to an agent mapped in the Memory Address Space. When the target returns “ready”, it assumes responsibility for the coherency (which includes ordering) of the subject data.

### Configuration Read Command

The Configuration Read command reads the configuration space of each agent. An agent is selected during a configuration access when its IDSEL signal is asserted and AD(1-0) are 00. During the address phase of a configuration cycle, AD(7-2) address one of the 64 dword registers (where byte enables address of the bytes within each dword) in the configuration space of each device and AD(31-11) are logical don't cares to the selected agent. AD(10-8) indicate which device of a multi-function agent is being addressed.

## Configuration Write Command

The Configuration Write command transfers data to the configuration space of each agent. An agent is selected when its IDSEL signal is asserted and AD(1-0) are 00. During the address phase of a configuration cycle, the AD(7-2) lines address the 64 dword registers (where byte enables address of the bytes within each dword) in the configuration space of each device, and AD(31-11) are logical don't cares to the selected agent. AD(10-8) indicate which device of a multi-function agent is addressed.

## Memory Read Multiple Command

This command is identical to the Memory Read command except that it additionally indicates that the master may intend to fetch more than one cache line before disconnecting. The SYM53C876 supports PCI Read Multiple functionality and issues Read Multiple commands on the PCI bus when the Read Multiple Mode is enabled. This mode is enabled by setting bit 2 of the DMODE register (ERMP). If cache mode is enabled, a Read Multiple command is issued on all read cycles, except op code fetches, when the following conditions are met:

1. The CLSE bit (Cache Line Size Enable, DCNTL, bit 7) and the ERMP bit (Enable Read Multiple, DMODE, bit 2) are set.
2. The Cache Line Size register for each function contains a legal burst size value (2, 4, 8, 16, 32, 64, or 128) and that value is less than or equal to the DMODE burst size.
3. The number of bytes to transfer at the time a cache boundary is reached is at least twice the full cache line size.
4. The chip is aligned to a cache line boundary.

When these conditions are met, the chip issues a Read Multiple command instead of a Memory Read during all PCI read cycles.

## Burst Size Selection

The Read Multiple command reads in multiple cache lines of data in a single bus ownership. The number of cache lines to read is a multiple of the cache line size as allowed for in Revision 2.1 of the PCI specification. The logic selects the largest multiple of the cache line size based on the amount of data to transfer, with the maximum allowable burst size determined from the DMODE burst size bits, and the CTEST5, bit 2.

## Dual Address Cycles Command

The SYM53C876 does not respond to this command as a slave, and it never generates this command as a master.

## Memory Read Line Command

This command is identical to the Memory Read command, except that it additionally indicates that the master intends to fetch a complete cache line. This command is intended for use with bulk sequential data transfers where the memory system and the requesting master might gain some performance advantage by reading up to a cache line boundary rather than a single memory cycle. The Read Line function that exists in the previous SYM53C8XX chips is modified in the SYM53C876 to reflect the PCI Cache Line Size register specifications. The functionality of the Enable Read Line bit (DMODE register, bit 3) is modified to more resemble the Write and Invalidate mode in terms of conditions that must be met before a Read Line command is issued. However, the Read Line option operates exactly like the previous SYM53C8XX chips when cache mode is disabled by a CLSE bit reset or when certain conditions exist in the chip (explained below).

If cache mode is disabled, Read Line commands are issued on every read data transfer, except on code fetches, as in previous SYM53C8XX chips.

If cache mode is enabled, a Read Line command is issued on all read cycles, except on code fetches, when the following conditions are met:

1. The CLSE (Cache Line Size Enable, DCNTL, bit 7) and ERL (Enable Read Line, DMODE, bit 3) bits are set.
2. The Cache Line Size register for each function must contain a legal burst size value (2, 4, 8, 16, 32, 64, or 128) and that value is less than or equal to the DMODE burst size.
3. The number of bytes to be transferred at the time a cache boundary is reached is equal to or greater than the DMODE burst size.
4. The chip is aligned to a cache line boundary.

When these conditions are met, the chip issues a Read Line command instead of a Memory Read during all PCI read cycles. Otherwise, it issues a normal Memory Read command.

### **Read Multiple with Read Line Enabled**

When both the Read Multiple and Read Line modes are enabled, the Read Line command is not issued if the above conditions are met. Instead, a Read Multiple command is issued, even though the conditions for Read Line are met.

If the Read Multiple mode is enabled and the Read Line mode is disabled, Read Multiple commands are issued if the Read Multiple conditions are met.

### **Memory Write and Invalidate Command**

The Memory Write and Invalidate command is identical to the Memory Write command, except that it additionally guarantees a minimum transfer of one complete cache line; that is to say, the master intends to write all bytes within the addressed cache line in a single PCI transaction unless interrupted by the target. This command requires implementation of the PCI Cache Line Size register at address 0Ch in the PCI Configuration

Space. The SYM53C876 enables Memory Write and Invalidate cycles when bit 0 in the CTEST3 register (WRIE) and bit 4 in the PCI Command register (WIE) are set. When the following conditions are met, Memory Write and Invalidate commands are issued:

1. The CLSE bit (Cache Line Size Enable, DCNTL, bit 7), WRIE bit (Write and Invalidate Enable, CTEST3, bit 0), and PCI configuration Command register, bit 4 are set.
2. The Cache Line Size register for each function contains a legal burst size value (2, 4, 8, 16, 32, 64, or 128) and that value is less than or equal to the DMODE burst size.
3. The chip has enough bytes in the DMA FIFO to complete at least one full cache line burst.
4. The chip is aligned to a cache line boundary.

When these conditions are met, the SYM53C876 issues a Write and Invalidate command instead of a Memory Write command during all PCI write cycles.

### **Multiple Cache Line Transfers**

The Write and Invalidate command can write multiple cache lines of data in a single bus ownership. The chip issues a burst transfer as soon as it reaches a cache line boundary. The size of the transfer is not automatically the cache line size, but rather a multiple of the cache line size as allowed for in Revision 2.1 of the PCI specification. The logic selects the largest multiple of the cache line size based on the amount of data to transfer, with the maximum allowable burst size determined from the DMODE burst size bits, and CTEST5, bit 2. If multiple cache line size transfers are not desired, set the DMODE burst size to exactly the cache line size, and the chip only issues single cache line transfers.

After each data transfer, the chip re-evaluates the burst size based on the amount of remaining data to transfer and again selects the highest possible multiple of the cache line size, no larger than the DMODE burst size. The most likely scenario of this scheme is that the chip selects the DMODE

burst size after alignment and issues bursts of this size. The burst size is, in effect, throttled down toward the end of a long Memory Move or Block Move transfer until only the cache line size burst size is left. The chip finishes the transfer with this burst size.

### **Latency**

In accordance with the PCI specification, the chip's latency timer is ignored when issuing a Write and Invalidate command such that when a latency time-out occurs, the SYM53C876 continues to transfer up to a cache line boundary. At that point, the chip relinquishes the bus and finishes the transfer at a later time using another bus ownership. If the chip is transferring multiple cache lines, it continues to transfer until the next cache boundary is reached.

### **PCI Target Retry**

During a Write and Invalidate transfer, if the target device issues a retry (STOP with no TRDY, indicating that no data was transferred), the chip relinquishes the bus and immediately tries to finish the transfer on another bus ownership. The chip issues another Write and Invalidate command on the next ownership, in accordance with the PCI specification.

### **PCI Target Disconnect**

During a Write and Invalidate transfer, if the target device issues a disconnect the SYM53C876 relinquishes the bus and immediately tries to finish the transfer on another bus ownership. The chip does not issue another Write and Invalidate command on the next ownership unless the address is aligned.

---

## **Internal Arbiter**

The PCI-SCSI controller uses a single REQ/-GNT/ signal pair to arbitrate for access to the PCI bus. The SYM53C876 uses a round-robin arbitration scheme to allow both SCSI functions to arbitrate for PCI bus access.

An internal arbiter circuit allows the different bus-mastering functions resident in the chip to arbitrate among themselves for the privilege of arbitrating for PCI bus access. There are two independent bus-mastering functions inside the SYM53C876, one for each of the SCSI functions.

---

## **PCI Cache Mode**

The SYM53C876 supports the PCI specification for an 8-bit Cache Line Size register located in the PCI Configuration Space. The Cache Line Size register provides the ability to sense and react to non-aligned addresses corresponding to cache line boundaries. In conjunction with the Cache Line Size register, the PCI commands Read Line, Read Multiple, and Write and Invalidate are each software enabled or disabled to allow the user full flexibility in using these commands.

### **Selection of Cache Line Size**

The cache logic for each bus mastering function selects a cache line size based on the values for the burst size in the DMODE register, and the PCI Cache Line Size register, whichever is appropriate.

**Note:** Each bus mastering function does not automatically use the value in its PCI Cache Line Size register as the cache line size value. The chip scales the value of the Cache Line Size register down to the nearest binary burst size allowed by the chip (2, 4, 8, 16, 32, 64, or 128). The SCSI function

compares this value to the DMODE burst size, then selects the smaller as the value for the cache line size.

### Alignment

The SYM53C876 uses the calculated line size value to monitor the current address for alignment to the cache line size. When it is not aligned, the chip attempts to align to the cache boundary by using a “smart aligning” scheme. This means that it attempts to use the largest burst size possible that is less than the cache line size, to reach the cache boundary quickly with no overflow. This process is a stepping mechanism that steps up to the highest possible burst size based on the current address.

The stepping process begins at a 4-dword boundary. The SYM53C876 first tries to align to a 4-dword boundary (0x0000, 0x0010, 0x0020, etc.) by using single dword transfers (no bursting). Once this boundary is reached, the chip evaluates the current alignment to various burst sizes allowed, and selects the largest possible as the next burst size, while not exceeding the cache line size. The chip then issues this burst and re-evaluates the alignment to various burst sizes, again selecting the largest possible while not exceeding the cache line size, as the next burst size. This stepping process continues until the chip reaches the cache line size boundary or runs out of data. Once a cache line boundary is reached, the chip uses the cache line size as the burst size from then

on, except in the case of multiples (explained below). The alignment process is finished at this point.

### Example: Cache Line Size = 16, Current Address = 0x01h

The chip is not aligned to a 4-dword cache boundary (the stepping threshold), so it issues 4 single-dword transfers (the first is a 3-byte transfer). At address 0x10, the chip is aligned to a 4-dword boundary, but not aligned to any higher burst size boundaries that are less than the cache line size. So, the part issues a burst of 4. At this point, the address is 0x20, and the chip evaluates that it is aligned not only to a 4-dword boundary, but also to an 8-dword boundary. It selects the highest, 8, and bursts 8 dwords. At this point, the address is 0x40h, which is a cache line size boundary. Alignment stops, and the burst size from then on is switched to 16.

### Memory Move Misalignment

The SYM53C876 does not operate in a cache alignment mode when a Memory Move instruction type is issued and the read and write addresses are different distances from the nearest cache line boundary. For example, if the read address is 0x21F and the write address is 0x42F, and the cache line size is eight (8), the addresses are byte aligned, but they are not the same distance from the nearest cache boundary. The read address is 1 byte from the cache boundary 0x220 and the write address is 17 bytes from the cache boundary 0x440. In this situation, the chip does not align to cache boundaries.

---

# SCSI Functional Description

---

---

## Two SCSI Controllers

The SYM53C876 provides two SCSI controllers on a single chip. Each SCSI controller provides a SCSI function that supports an 8-bit or 16-bit bus. Each supports Ultra SCSI synchronous transfer rates up to 40 MB/s, Ultra SCSI synchronous transfer rates up to 20 MB/s, and asynchronous transfer rates up to 14 MB/s on a wide SCSI bus. The SCSI functions are programmed with SCSI SCRIPTS, making it easy to “fine tune” the system for specific mass storage devices or SCSI-2 requirements.

The SYM53C876 offers low-level register access or a high-level control interface. Like first generation SCSI devices, the SYM53C876 is accessed as a register-oriented device. The ability to sample and/or assert any signal on the SCSI bus is used in error recovery and diagnostic procedures. In support of SCSI loopback diagnostics, each SCSI function may perform a self-selection and operate as both an initiator and a target.

The SYM53C876 is controlled by the integrated SCRIPTS processor through a high-level logical interface. Commands controlling the SCSI functions are fetched out of the main host memory or local memory. These commands instruct the SCSI functions to Select, Reselect, Disconnect, Wait for a Disconnect, Transfer Information, Change Bus Phases and, in general, implement all aspects of the SCSI protocol. The SCRIPTS processor is a special high-speed processor optimized for SCSI protocol.

---

## SCRIPTS Processor

The SCSI SCRIPTS processor allows both DMA and SCSI commands to be fetched from host memory or internal SCRIPTS RAM. Algorithms written in SCSI SCRIPTS control the actions of the SCSI and DMA cores. The SCRIPTS processor executes complex SCSI bus sequences independently of the host CPU.

Algorithms may be designed to tune SCSI bus performance, to adjust to new bus device types (such as scanners, communication gateways, etc.), or to incorporate changes in the SCSI-2 or SCSI-3 logical bus definitions without sacrificing I/O performance. SCSI SCRIPTS are hardware-independent, so they can be used interchangeably on any host or CPU system bus.

## Internal SCRIPTS RAM

The SYM53C876 has 4KB (1024 x 32 bits) of internal, general purpose RAM for each SCSI function. The RAM is designed for SCRIPTS program storage, but is not limited to this type of information. When the chip fetches SCRIPTS instructions or Table Indirect information from the internal RAM, these fetches remain internal to the chip and do not use the PCI bus. Other types of access to the RAM by the chip use the PCI bus, as if they were external accesses. The MAD5 pin disables the 4K internal RAM. To disable the internal RAM, connect a 4.7K  $\Omega$  resistor between the MAD5 pin and  $V_{SS}$  (ground). The SCRIPTS RAM by default powers-up enabled.

The RAM can be relocated by the PCI system BIOS anywhere in 32-bit address space. The Base Address Two register in PCI configuration space contains the base address of the internal RAM. This register is similar to the ROM Base Address register in PCI configuration space. To simplify loading of SCRIPTS instructions, the base address of the RAM

appears in the SCRATCHB register when bit 3 of the CTEST2 register is set. The RAM is byte-accessible from the PCI bus and is visible to any bus-mastering device on the bus. External accesses to the RAM (by the CPU) follow the same timing sequence as a standard slave register access, except that the target wait states required drops from 5 to 3.

A complete set of development tools is available for writing custom drivers with SCSI SCRIPTS. For more information on the SCSI SCRIPTS instructions supported by the SYM53C876, see Chapter 5, *SCSI SCRIPTS Instruction Set*.

### **Prefetching SCRIPTS Instructions**

When enabled by setting the Prefetch Enable bit (bit 5) in the DCNTL register, the prefetch logic in the SYM53C876 fetches 8 dwords of instructions. The prefetch logic automatically determines the maximum burst size that it can perform, based on the burst length as determined by the values in the DMODE register. If the unit cannot perform bursts of at least four dwords, the prefetch logic disables itself. While the chip is prefetching SCRIPTS instructions, the PCI Cache Line Size register value does not have any effect and the Read Line, Read Multiple, and Write and Invalidate commands are not used.

**Note:** This feature is only useful if fetching SCRIPTS instructions from main memory. Due to the short access time of SCRIPTS RAM, prefetching is not necessary when fetching instructions from this memory.

The SYM53C876 may flush the contents of the prefetch unit under certain conditions, listed below, to ensure that the chip always operates from the most current version of the SCRIPTS instruction. When one of these conditions apply, the contents of the prefetch unit are flushed automatically.

1. On every Memory Move instruction. The Memory Move instruction often places modified code directly into memory. To make

sure that the chip executes all recent modifications, the prefetch unit flushes its contents and loads the modified code every time a instruction is issued. To avoid inadvertently flushing the prefetch unit contents, use the No Flush option for all Memory Move operations that do not modify code within the next 8 dwords. For more information on this instruction, refer to Chapter 5, *SCSI SCRIPTS Instruction Set*.

2. On every Store instruction. The Store instruction may also be used to place modified code directly into memory. To avoid inadvertently flushing the prefetch unit contents, use the No Flush option for all Store operations that do not modify code within the next 8 dwords.
3. On every write to the DSP.
4. On all Transfer Control instructions when the transfer conditions are met. This is necessary because the next instruction to execute is not the sequential next instruction in the prefetch unit.
5. When the Prefetch Flush bit (DCNTL bit 6) is set. The unit flushes whenever this bit is set. The bit is self-clearing.

### **Op Code Fetch Burst Capability**

Setting the Burst Op Code Fetch Enable bit (bit 1) in the DMODE register (38h) causes the SYM53C876 to burst in the first 2 dwords of all instruction fetches. If the instruction is a memory-to-memory move, the third dword is accessed in a separate ownership. If the instruction is an indirect type, the additional dword is accessed in a subsequent bus ownership. If the instruction is a table indirect Block Move, the chip uses two accesses to obtain the 4 dwords required, in two bursts of 2 dwords each.

**Note:** This feature is only useful if prefetching is disabled.

**Note:** This feature is only useful if fetching SCRIPTS instructions from main



memory. Due to the short access time of SCRIPTS RAM, burst op code fetching is not necessary when fetching instructions from this memory.

### Load/Store Instructions

The SYM53C876 supports the Load/Store instruction type, which simplifies the movement of data between memory and the internal chip registers. It also enables the chip to transfer bytes to addresses relative to the DSA register. For more information on the Load and Store instructions, refer to Chapter 5, *SCSI SCRIPTS Instruction Set*.

### JTAG Boundary Scan Testing

The SYM53C876 includes support for JTAG boundary scan testing in accordance with the IEEE 1149.1 specification, with one exception which is explained in this section. This device accepts all required boundary scan instructions, including the optional CLAMP, HIGHZ, and IDCODE instructions.

The SYM53C876 uses an 8-bit instruction register to support all boundary scan instructions. The data registers included in the device are the Boundary Data register, the IDCODE register, and the Bypass register. This device can handle a 10 MHz TCK frequency for TDO and TDI.

Due to design constraints, the RST/ pin (system reset) always tri-states the SCSI pins when it is asserted. Boundary scan logic does not control this action, and this is not compliant with the specification. There are two solutions that resolve this issue:

1. Use the RST/ pin as a boundary scan compliance pin. When the pin deasserts,

the device is boundary scan compliant and when it asserts, the device is non-compliant. To maintain compliance, the RST/ pin must be driven high.

2. When RST/ asserts during boundary scan testing, the expected output on the SCSI pins must be the high-z condition, and not what is contained in the boundary scan data registers for the SCSI pin output cells.

### SCSI Loopback Mode

The SYM53C876 loopback mode allows testing of both initiator and target functions and, in effect, lets the chip communicate with itself. When the Loopback Enable bit is set in the STEST2 register, bit 4, the SYM53C876 allows control of all SCSI signals, whether the chip is operating in initiator or target mode. For more information on this mode of operation, refer to the *SYM53C8XX Family Programming Guide*.

### Parity Options

The SYM53C876 implements a flexible parity scheme that allows control of the parity sense, allows parity checking to be turned on or off, and has the ability to deliberately send a byte with bad parity over the SCSI bus to test parity error recovery procedures. Table 2-4 defines the bits that are involved in parity control and observation. Table 2-5 describes the parity control function of the Enable Parity Checking and Assert SCSI Even Parity bits in the SCNTL1 register, bit 2. Table 2-6 describes the options available when a parity error occurs. Figure 2-2 shows where parity checking is done in the SYM53C876.

**Table 2-2: Bits Used for Parity Control and Generation**

Bit Name	Location	Description
Assert SATN/ on Parity Errors	SCNTL0, Bit 1	Causes the 53C876 to automatically assert SATN/ when it detects a SCSI parity error while operating as an initiator.
Enable Parity Checking	SCNTL0, Bit 3	Enables the 53C876 to check for parity errors. The 53C876 checks for odd parity.
Assert Even SCSI Parity	SCNTL1, Bit 2	Determines the SCSI parity sense generated by the 53C876 to the SCSI bus.
Disable Halt on SATN/ or a Parity Error (Target Mode Only)	SCNTL1, Bit 5	Causes the 53C876 not to halt operations when a parity error is detected in target mode.
Enable Parity Error Interrupt	SIEN0, Bit 0	Determines whether the 53C876 generates an interrupt when it detects a SCSI parity error.
Parity Error	SIST0, Bit 0	This status bit is set whenever the 53C876 detects a parity error on the SCSI bus.
Status of SCSI Parity Signal	SSTAT0, Bit 0	This status bit represents the active high current state of the SCSI SDP0 parity signal.
SCSI SDP1 Signal	SSTAT2, Bit 0	This bit represents the active high current state of the SCSI SDP1 parity signal.
Latched SCSI Parity	SSTAT 2, Bit 3 and SSTAT1, Bit 3	These bits reflect the SCSI odd parity signal corresponding to the data latched into the SIDL register
Master Parity Error Enable	CTEST4, Bit 3	Enables parity checking during PCI master data phases.
Master Data Parity Error	DSTAT, Bit 6	Set when the 53C876, as a PCI master, detects a target device signaling a parity error during a data phase.
Master Data Parity Error Interrupt Enable	DIEN, Bit 6	By clearing this bit, a Master Data Parity Error does not cause assertion of INTA/ (or INTB/), but the status bit is set in the DSTAT register.

**Table 2-3: SCSI Parity Control**

<b>EPC</b>	<b>ASEP</b>	<b>Description</b>
0	0	Does not check for parity errors. Parity is generated when sending SCSI data. Asserts odd parity when sending SCSI data.
0	1	Does not check for parity errors. Parity is generated when sending SCSI data. Asserts even parity when sending SCSI data.
1	0	Checks for odd parity on SCSI data received. Parity is generated when sending SCSI data. Asserts odd parity when sending SCSI data.
1	1	Checks for odd parity on SCSI data received. Parity is generated when sending SCSI data. Asserts even parity when sending SCSI data.

*Key: EPC = Enable Parity Checking (bit 3 SCNTL0); ASEP = Assert SCSI Even Parity (bit 2 SCNTL1)*

**Table 2-4: SCSI Parity Errors and Interrupts**

<b>DHP</b>	<b>PAR</b>	<b>Description</b>
0	0	Halts when a parity error occurs in target or initiator mode and does NOT generate an interrupt.
0	1	Halts when a parity error occurs in target mode and generates an interrupt in target or initiator mode.
1	0	Does not halt in target mode when a parity error occurs until the end of the transfer. An interrupt is not generated.
1	1	Does not halt in target mode when a parity error occurs until the end of the transfer. An interrupt is generated.

*Key: DHP = Disable Halt on SATN/ or Parity Error (bit 5 SCNTL1); PAR = Parity Error (bit 0 SIEN0)*

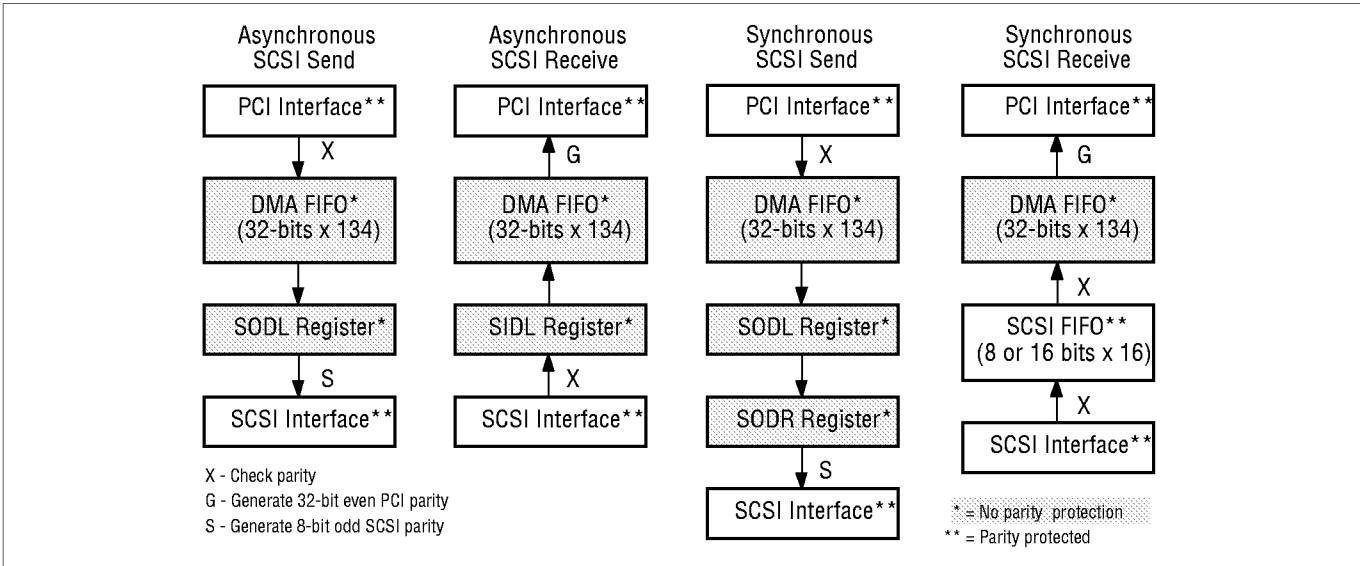
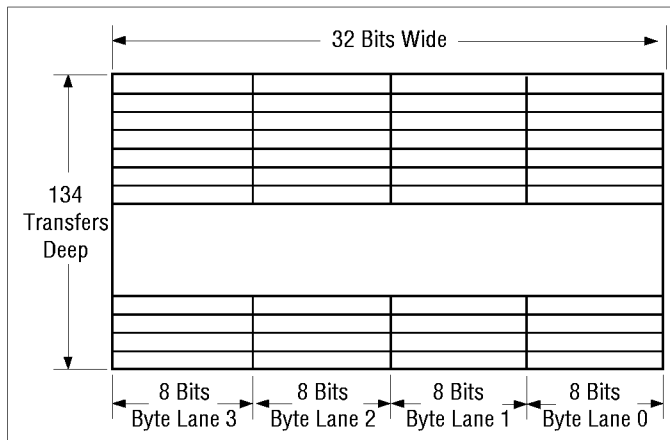

**Figure 2-2: Parity Checking/Generation**

## DMA FIFO

The DMA FIFO is 4 bytes wide by 134 transfers deep. The DMA FIFO is illustrated in Figure 2-3. The default DMA FIFO size is 88 bytes to assure

compatibility with older products in the SYM53C8XX family; the user may set the DMA FIFO size to 536 bytes by setting the DMA FIFO Size bit, bit 5 in the CTEST5 register.



**Figure 2-3: DMA FIFO Sections**

The SYM53C876 supports 32-bit memory and automatically supports misaligned DMA transfers. A 536-byte FIFO allows the 53C876 to support 2, 4, 8, 16, 32, 64, or 128 dword bursts

across the PCI bus interface.

## Data Paths

The data path through the SYM53C876 depends on whether data is being moved into or out of the chip, and whether SCSI data is being transferred asynchronously or synchronously.

Figure 2-4 shows how data is moved to/from the SCSI bus in each of the different modes.

The following steps determine if any bytes remain in the data path when the chip halts an operation:

### Asynchronous SCSI Send

1. If the DMA FIFO size is set to 88 bytes, look at the DFIFO and DBC registers and calculate if there are bytes left in the DMA FIFO. To make this calculation, subtract the seven least significant bits of the DBC register from the 7-bit value of the DFIFO register. AND the result with 7Fh for a byte count between zero and 88.

If the DMA FIFO size is set to 536 bytes (using bit 5 of the CTEST5 register), subtract the 10 least significant bits of the DBC register from the 10-bit value of the DMA FIFO Byte Offset Counter, which consists of bits 1-0 in the CTEST5 register and bits 7-0 of the DMA FIFO register. AND the result with 3FFh for a byte count between 0 and 536.

2. Read bit 5 in the SSTAT0 and SSTAT2 registers to determine if any bytes are left in the SODL register. If bit 5 is set in the SSTAT0 or SSTAT2, then the least significant byte or the most significant byte in the SODL register is full, respectively. Checking this bit also reveals bytes left in the SODL register from a Chained Move operation with an odd byte count.

### Synchronous SCSI Send

1. If the DMA FIFO size is set to 88 bytes,

look at the DFIFO and DBC registers and calculate if there are bytes left in the DMA FIFO. To make this calculation, subtract the seven least significant bits of the DBC register from the 7-bit value of the DFIFO register. AND the result with 7Fh for a byte count between zero and 88.

If the DMA FIFO size is set to 536 bytes (using bit 5 of the CTEST5 register), subtract the 10 least significant bits of the DBC register from the 10-bit value of the DMA FIFO Byte Offset Counter, which consists of bits 1-0 in the CTEST5 register and bits 7-0 of the DMA FIFO register. AND the result with 3FFh for a byte count between 0 and 536.

2. Read bit 5 in the SSTAT0 and SSTAT2 registers to determine if any bytes are left in the SODL register. If bit 5 is set in the SSTAT0 or SSTAT2, then the least significant byte or the most significant byte in the SODL register is full, respectively. Checking this bit also reveals bytes left in the SODL register from a Chained Move operation with an odd byte count.
3. Read bit 6 in the SSTAT0 and SSTAT2 registers to determine if any bytes are left in the SODR register. If bit 6 is set in the SSTAT0 or SSTAT2, then the least significant byte or the most significant byte in the SODR register is full, respectively.

### Asynchronous SCSI Receive

1. If the DMA FIFO size is set to 88 bytes, look at the DFIFO and DBC registers and calculate if there are bytes left in the DMA FIFO. To make this calculation, subtract the seven least significant bits of the DBC register from the 7-bit value of the DFIFO register. AND the result with 7Fh for a byte count between 0 and 88.

If the DMA FIFO size is set to 536 bytes

- (using bit 5 of the CTEST5 register), subtract the 10 least significant bits of the DBC register from the 10-bit value of the DMA FIFO Byte Offset Counter, which consists of bits 1-0 in the CTEST5 register and bits 7-0 of the DMA FIFO register. AND the result with 3FFh for a byte count between 0 and 536.
2. Read bit 7 in the SSTAT0 and SSTAT2 register to determine if any bytes are left in the SIDL register. If bit 7 is set in the SSTAT0 or SSTAT2, then the least significant byte or the most significant byte is full, respectively.
  3. If any wide transfers have been performed using the Chained Move instruction, read the Wide SCSI Receive bit (SCNTL2, bit 0) to determine whether a byte is left in the SWIDE register.

### Synchronous SCSI Receive

1. If the DMA FIFO size is set to 88 bytes, subtract the seven least significant bits of the DBC register from the 7-bit value of the DFIFO register. AND the result with 7Fh for a byte count between 0 and 88.

If the DMA FIFO size is set to 536 bytes (using bit 5 of the CTEST5 register), subtract the 10 least significant bits of the DBC register from the 10-bit value of the DMA FIFO Byte Offset Counter, which consists of bits 1-0 in the CTEST5 register and bits 7-0 of the DMA FIFO register. AND the result with 3FFh for a byte count between 0 and 536.

2. Read the SSTAT1 register and examine bits 7-4, the binary representation of the number of valid bytes in the SCSI FIFO, to determine if any bytes are left in the SCSI FIFO.
3. If any wide transfers have been performed using the Chained Move instruction, read the Wide SCSI Receive bit (SCNTL2, bit 0) to determine whether a byte is left in the SWIDE register.

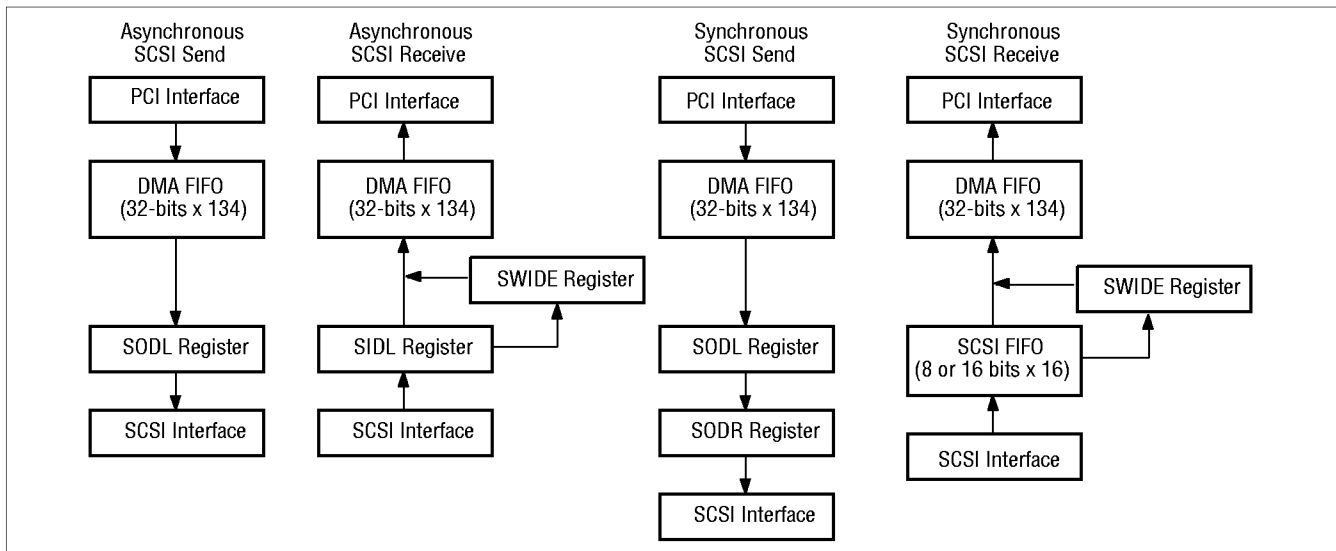

**Figure 2-4: SYM53C876 Host Interface SCSI Data Paths**

## SCSI Bus Interface

All SCSI signals are active low. The SYM53C876 contains the single-ended output drivers and can be connected directly to the SCSI bus. Each output is isolated from the power supply to ensure that a powered-down SYM53C876 has no effect on an active SCSI bus (CMOS “voltage feed-through” phenomena). TolerANT technology provides signal filtering at the inputs of SREQ/ and SACK/ to increase immunity to signal reflections.

## Differential Mode

In differential mode, the SDIR (15-0), SDIRP0/1, IGS, TGS, RSTDIR, BSYDIR, and SELDIR signals control the direction of

external differential-pair transceivers. The SYM53C876 is placed in differential mode by setting the DIF bit, bit 5 of the STEST2 register (4Eh). Setting this bit tri-states the BSY/, SEL/, and RST/ pads so they can be used as pure input pins. When TolerANT active negation is enabled, the recommended resistor value on the REQ/, ACK/, MSG/, C\_D/, I\_O/, ATN/, SD15-0, and SDP1-0/signals is 1.5 K $\Omega$ . In addition to the standard SCSI lines, the following signals are used during differential operation by the SYM53C876:

Signal	Function
BSYDIR, SELDIR, RSTDIR	Active high signals used to enable the differential drivers as outputs for SCSI signals BSY/, SEL/, and RST/, respectively
SDIR(15-0), SDIRP(0/1)	Active high signals used to control direction of the differential drivers for SCSI data and parity lines, respectively
IGS	Active high signal used to control direction of the differential driver for initiator group signals ATN/ and ACK/
TGS	Active high signal used to control direction of the differential drivers for target group signals MSG/, C/D/, I/O/, and REQ/
DIFFSENS	Input to the SYM53C876 used to detect the presence of a single-ended device on a differential system. If a logical zero is detected on this pin, then it is assumed that a single-ended device is on the bus and all SCSI outputs are tri-stated to avoid damage to the transceiver.

See Figure 2-5 for an example differential wiring diagram, in which the SYM53C876 is connected to the TI SN75976A differential transceiver. The recommended value of the pull-up resistor on the REQ/, ACK/, MSG/, C/D/, I/O/, ATN/, SD0-15/, SDP0/, and SDP1/ lines is 680  $\frac{3}{4}$  when the Active Negation portion of Symbios Logic TolerANT technology is not enabled. When TolerANT is enabled, the recommended resistor value on the REQ/, ACK/, SD7-0/, and SDP0/ signals

is 1.5 K $\Omega$ . The electrical characteristics of these pins change when TolerANT is enabled, permitting a higher resistor value.

To interface the SYM53C876 to the SN75976A, connect the DIR pins, as well as IGS and TGS, of the SYM53C876 directly to the transceiver enables (nDE/RE/). These signals control the direction of the channels on the SN75976A.

The SCSI bi-directional control and data pins (SD15-0/, SDP0/, SDP1/, REQ/, ACK/, MSG/, I\_O/, C\_D/, and ATN/) of the SYM53C876 connect to the bi-directional data pins (nA) of the SN75976A with a pull-up resistor. The three remaining pins, SEL/, BSY/, and RST/ are connected to the SN75976A with a pull-down resistor. The pull-down resistors are required when the pins (nA) of the SN75976A are configured as inputs. When the data pins are inputs, the resistors provide a bias voltage to both the SYM53C876 pins (SEL/, BSY/, and RST/) and the SN75976A data pins. Because the SEL/, BSY/, and RST/ pins on the SYM53C876 are inputs only, this configuration allows for the SEL/, BSY/, and RST/ SCSI signals to be asserted on the SCSI bus. The differential pairs

on the SCSI bus are reversed when connected to the SN75976A, due to the active low nature of the SCSI bus.

The pull-up value should be no lower than the transceiver  $I_{OL}$  can tolerate, but not so high as to cause RC timing problems.

Note: Use the TI SN75976A differential transceivers to achieve Ultra SCSI transfer rates.

### **8-bit/16-bit SCSI and the Differential Interface**

In an 8-bit SCSI bus, the SD15-8 pins on the SYM53C876 should be pulled up with a 1.5 K  $\Omega$  resistor or terminated like the rest of the SCSI bus lines. This is very important, as errors may occur during reselection if these lines are left floating.



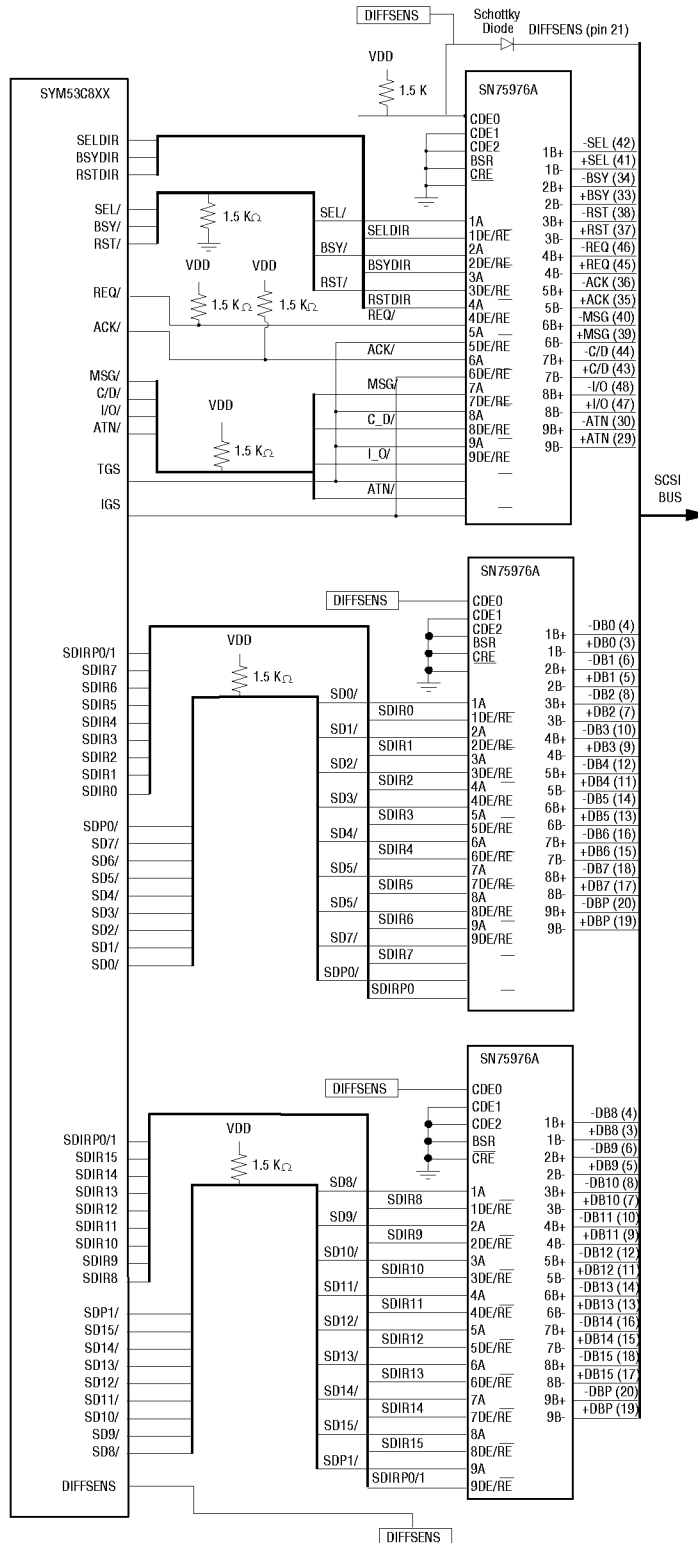

**Figure 2-5: SYM53C876 Differential Wiring Diagram**

## Terminator Networks

The terminator networks provide the biasing needed to pull signals to an inactive voltage level, and to match the impedance seen at the end of the cable with the characteristic impedance of the cable. Install terminators at the extreme ends of the SCSI chain, and only at the ends; no system should ever have more or less than two terminators installed and active. SCSI host adapters should provide a means of accommodating terminators. The terminators should be socketed, so that if not needed they may be removed, or there should be a means of disabling them with software.

Single-ended cables can use a 220 Ω pull-up to the terminator power supply (Term-Power) line and a 330 Ω pull-down to Ground. Because of the high-performance nature of the SYM53C876, Regulated (or Active) termination is recommended. Figure 2-6 shows a Unitrode™ active terminator. For additional information, refer to the SCSI-2 Specification. TolerANT active negation is compatible with either termination network.

**Note:** If the SYM53C876 is used in a design with only an 8-bit SCSI bus, all 16 data lines still must be terminated or pulled high.

**Note:** Active termination is required for Wide Ultra SCSI synchronous transfers.

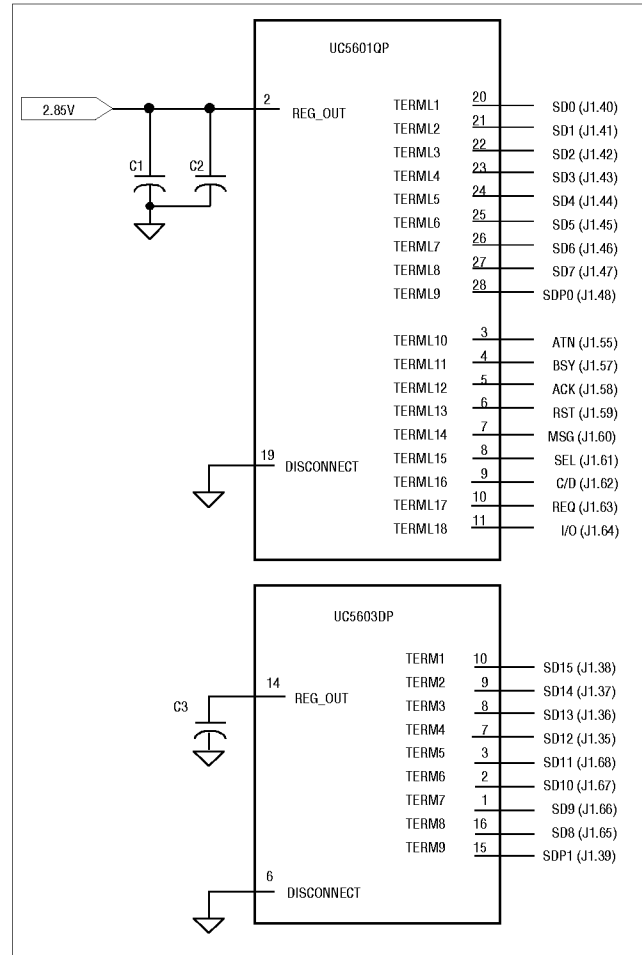

### Key

- |    |                                    |
|----|------------------------------------|
| C1 | 10 μF SMT                          |
| C2 | 0.1 μF SMT                         |
| C3 | 2.2 μF SMT                         |
| J1 | 68-pin, high density "P" connector |

**Figure 2-6: Regulated Termination**

## Synchronous Operation

The SYM53C876 can transfer synchronous SCSI data in both initiator and target modes. The SXFER register controls both the synchronous offset and the transfer period. It may be loaded by the CPU before SCRIPTS execution begins, from within SCRIPTS via a Table Indirect I/O instruction, or with a Read-Modify-Write instruction.

The SYM53C876 can receive data from the SCSI bus at a synchronous transfer period as short as 50 ns, regardless of the transfer period used to send data. The chip can receive data at one-fourth of the divided SCLK frequency. Depending on the SCLK frequency, the negotiated transfer period, and the synchronous clock divider, the chip can send synchronous data at intervals as short as 50 ns for Ultra SCSI, 100 ns for Fast SCSI and 200 ns for SCSI-1.

### Determining the Data Transfer Rate

Synchronous data transfer rates are controlled by bits in two different registers of the SYM53C876. A brief description of the bits is provided below. Figure 2-7 illustrates the clock division factors used in each register, and the role of the register bits in determining the transfer rate.

#### SCNTL3 Register, bits 6–4 (SCF2–0)

The SCF2-0 bits select the factor by which the frequency of SCLK is divided before being presented to the synchronous SCSI control logic. The output from this divider controls the rate at which data can be received; this rate must not exceed 80 MHz. The receive rate is 1/4 of the divider output.

#### SCNTL3 Register, bits 2–0 (CCF2–0)

The CCF2-0 bits select the factor by which the frequency of SCLK is divided before being presented to the asynchronous SCSI controller logic. This divider must be set according to the input clock frequency in the table.

#### SXFER Register, bits 7–5 (TP2–0)

The TP2-0 bits determine the SCSI synchronous transfer period when sending synchronous SCSI data in either initiator or target mode.

### Wide Ultra SCSI Synchronous Transfers

Wide Ultra SCSI is simply an extension of current Fast SCSI synchronous transfer specifications. It allows synchronous transfer periods to be negotiated down as low as 50 ns, which is half the 100 ns period allowed under Fast SCSI. This allows a maximum transfer rate of 40 MB/s on a 16-bit SCSI bus. The SYM53C876 requires that the 40 MHz clock is doubled by the internal clock doubler (see the STEST1 register description) to perform Wide Ultra SCSI transfers. In addition, the following bit values affect the chip's ability to support Wide Ultra SCSI synchronous transfer rates:

1. Clock Conversion Factor bits, SCNTL3 register bits 2-0 and Synchronous Clock Conversion Factor bits, SCNTL3 register bits 6-4. These fields now support a value of 101 (binary), allowing the SCLK frequency to be divided down by 4. This allows systems with a 40 MHz clock to operate at Fast SCSI-2 transfer rates as well as Wide Ultra SCSI rates, if needed.
2. Wide Ultra SCSI Mode Enable bit, SCNTL3 register bit 7. Setting this bit enables Wide Ultra SCSI synchronous transfers in systems that have a 40MHz clock using the internal clock doubler.
3. TolerANT Enable bit, STEST3 register bit 7. Setting this bit enables active negotiation.

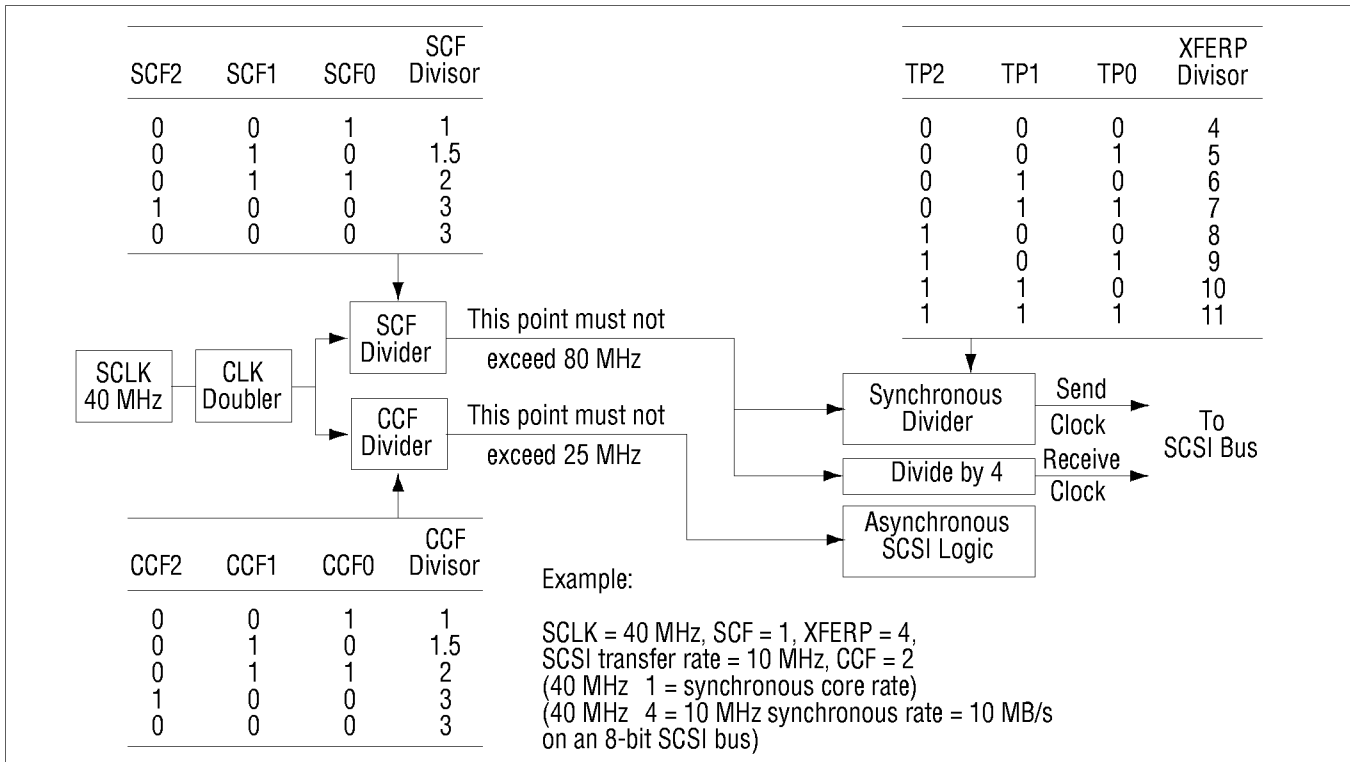

**Figure 2-7: Determining the Synchronous Transfer Rate**

## Designing a Wide Ultra SCSI System

Migrating an existing SCSI design from Fast SCSI to Wide Ultra SCSI requires minor software modifications as well as consideration for some hardware design guidelines. Since Wide Ultra SCSI is based on existing SCSI standards, it can use existing software programs as long as the software is able to negotiate for Wide Ultra SCSI synchronous transfer rates.

In the area of hardware, the primary area of concern in single-ended systems is to maintain signal integrity at high data transfer rates. To assure reliable operation at Wide Ultra SCSI transfer speeds, follow the system design parameters recommended in the Wide Ultra SCSI Parallel Interface draft standard, which is available from the

SCSI Web Site referenced at the beginning of this manual. Chapter 6 contains Wide Ultra SCSI timing information. In addition to the guidelines in the draft standard, make the following software and hardware adjustments to accommodate Wide Ultra SCSI transfers:

- Set the Wide Ultra SCSI Enable bit to enable Wide Ultra SCSI transfers.
- Set the TolerANT Enable bit, bit 7 in the STEST3 register whenever the Wide Ultra SCSI Enable bit is set.
- Do not extend the SREQ/SACK filtering period with STEST2 bit 1.
- Use a 40 MHz SCSI clock with an internal clock doubler.

## Interrupt Handling

The SCRIPTS processors in the SYM53C876 performs most functions independently of the host microprocessor. However, certain interrupt situations must be handled by the external microprocessor. This section explains all aspects of interrupts as they apply to the SYM53C876.

### Polling and Hardware Interrupts

The external microprocessor is informed of an interrupt condition by polling or hardware interrupts. Polling means that the microprocessor must continually loop and read a register until it detects a bit set that indicates an interrupt. This method is the fastest, but it wastes CPU time that could be used for other system tasks. The preferred method of detecting interrupts in most systems is hardware interrupts. In this case, the SYM53C876 asserts the Interrupt Request (INTA/ or INTB/) line that interrupts the microprocessor, causing the microprocessor to execute an interrupt service routine. A hybrid approach would use hardware interrupts for long waits, and use polling for short waits.

### Registers

The registers in the SYM53C876 that are used for detecting or defining interrupts are the ISTAT, SIST0, SIST1, DSTAT, SIEN0, SIEN1, DCNTL, and DIEN.

#### ISTAT

The ISTAT is the only register that can be accessed as a slave during SCRIPTS operation, therefore it is the register that is polled when polled interrupts are used. It is also the first register that should be read after the INTA/ (or INTB/) pin is asserted in association with a hardware interrupt. The INTF (Interrupt on the Fly) bit should be the first interrupt serviced. It must be written to one to be cleared. This interrupt must be cleared

before servicing any other interrupts. If the SIP bit in the ISTAT register is set, then a SCSI-type interrupt has occurred and the SIST0 and SIST1 registers should be read. If the DIP bit in the ISTAT register is set, then a DMA-type interrupt has occurred and the DSTAT register should be read. SCSI-type and DMA-type interrupts may occur simultaneously, so in some cases both SIP and DIP may be set.

#### SIST0 and SIST1

The SIST0 and SIST1 registers contain the SCSI-type interrupt bits. Reading these registers determines which condition or conditions caused the SCSI-type interrupt, and clears that SCSI interrupt condition. If the SYM53C876 is receiving data from the SCSI bus and a fatal interrupt condition occurs, the chip attempts to send the contents of the DMA FIFO to memory before generating the interrupt. If the SYM53C876 is sending data to the SCSI bus and a fatal SCSI interrupt condition occurs, data could be left in the DMA FIFO. Because of this the DMA FIFO Empty (DFE) bit in DSTAT should be checked. If this bit is clear, set the CLF (Clear DMA FIFO) and CSF (Clear SCSI FIFO) bits before continuing. The CLF bit is bit 2 in CTEST3. The CSF bit is bit 1 in STEST3.

#### DSTAT

The DSTAT register contains the DMA-type interrupt bits. Reading this register determines which condition or conditions caused the DMA-type interrupt, and clears that DMA interrupt condition. Bit 7 in DSTAT, DFE, is purely a status bit; it does not generate an interrupt under any circumstances and is not cleared when read. DMA interrupts flushes neither the DMA nor SCSI FIFOs before generating the interrupt, so the DFE bit in the DSTAT register should be checked after any DMA interrupt. If the DFE bit is clear, then the FIFOs must be cleared by set-

ting the CLF (Clear DMA FIFO) and CSF (Clear SCSI FIFO) bits, or flushed by setting the FLF (Flush DMA FIFO) bit.

### **SIEN0 and SIEN1**

The SIEN0 and SIEN1 registers are the interrupt enable registers for the SCSI interrupts in SIST0 and SIST1.

### **DIEN**

The DIEN register is the interrupt enable register for DMA interrupts in DSTAT.

### **DCNTL**

When bit 1 in this register is set, the INTA/ (or INTB/) pin is not asserted when an interrupt condition occurs. The interrupt is not lost or ignored, but merely masked at the pin. Clearing this bit when an interrupt is pending immediately causes the INTA/ (or INTB/) pin to assert. As with any register other than ISTAT, this register cannot be accessed except by a SCRIPTS instruction during SCRIPTS execution.

### **Fatal vs. Non-Fatal Interrupts**

A fatal interrupt, as the name implies, always causes SCRIPTS to stop running. All non-fatal interrupts become fatal when they are enabled by setting the appropriate interrupt enable bit. Interrupt masking is discussed later in this section. All DMA interrupts (indicated by the DIP bit in ISTAT and one or more bits in DSTAT being set) are fatal.

Some SCSI interrupts (indicated by the SIP bit in the ISTAT and one or more bits in SIST0 or SIST1 being set) are non-fatal. When the SYM53C876 is operating in Initiator mode, only the Function Complete (CMP), Selected (SEL), Reselected (RSL), General Purpose Timer Expired (GEN), and Handshake to Handshake Timer Expired (HTH) interrupts are non-fatal. When operating in Target mode CMP, SEL, RSL, Target mode: SATN/ active (M/A), GEN, and HTH are non-fatal. Refer to the description for

the Disable Halt on a Parity Error or SATN/ active (Target Mode Only) (DHP) bit in the SCNTL1 register to configure the chip's behavior when the SATN/ interrupt is enabled during Target mode operation. The Interrupt on the Fly interrupt is also non-fatal, since SCRIPTS can continue when it occurs.

The reason for non-fatal interrupts is to prevent SCRIPTS from stopping when an interrupt occurs that does not require service from the CPU. This prevents an interrupt when arbitration is complete (CMP set), when the SYM53C876 is selected or reselected (SEL or RSL set), when the initiator asserts ATN (target mode: SATN/ active), or when the General Purpose or Handshake to Handshake timers expire. These interrupts are not needed for events that occur during high-level SCRIPTS operation.

### **Masking**

Masking an interrupt means disabling or ignoring that interrupt. Interrupts can be masked by clearing bits in the SIEN0 and SIEN1 (for SCSI interrupts) registers or DIEN (for DMA interrupts) register. How the chip responds to masked interrupts depends on: whether polling or hardware interrupts are being used; whether the interrupt is fatal or non-fatal; and whether the chip is operating in Initiator or Target mode.

If a non-fatal interrupt is masked and that condition occurs, SCRIPTS do not stop, the appropriate bit in the SIST0 or SIST1 is still set, the SIP bit in the ISTAT is not set, and the INTA/ (or INTB/) pin is not asserted. See the section on non-fatal vs. fatal interrupts for a list of the non-fatal interrupts.

If a fatal interrupt is masked and that condition occurs, then SCRIPTS still stop, the appropriate bit in the DSTAT, SIST0, or SIST1 register is set, and the SIP or DIP bits in the ISTAT is set, but the INTA/ (or INTB/) pin is not asserted.

When the chip is initialized, enable all fatal interrupts if you are using hardware interrupts. If a fatal interrupt is disabled and that interrupt con-

dition occurs, SCRIPTS halts and the system never knows it unless it times out and checks the ISTAT after a certain period of inactivity.

If you are polling the ISTAT instead of using hardware interrupts, then masking a fatal interrupt makes no difference since the SIP and DIP bits in the ISTAT inform the system of interrupts, not the INTA/ (or INTB/) pin.

Masking an interrupt after INTA/ (or INTB/) is asserted does not cause deassertion of INTA/ (or INTB/).

### **Stacked Interrupts**

The SYM53C876 stacks interrupts if they occur one after the other. If the SIP or DIP bits in the ISTAT register are set (first level), then there is already at least one pending interrupt, and any future interrupts are stacked in extra registers behind the SIST0, SIST1, and DSTAT registers (second level). When two interrupts have occurred and the two levels of the stack are full, any further interrupts sets additional bits in the extra registers behind SIST0, SIST1, and DSTAT. When the first level of interrupts are cleared, all the interrupts that came in afterward moves into the SIST0, SIST1, and DSTAT. After the first interrupt is cleared by reading the appropriate register, the INTA/ (or INTB/) pin deasserts for a minimum of three CLKs; the stacked interrupts move into the SIST0, SIST1, or DSTAT; and the INTA/ (or INTB/) pin asserts once again.

Since a masked non-fatal interrupt does not set the SIP or DIP bits, interrupt stacking does not occur. A masked, non-fatal interrupt still posts the interrupt in SIST0, but does not assert the INTA/ (or INTB/) pin. Since no interrupt is generated, future interrupts move right into the SIST0 or SIST1 instead of being stacked behind another interrupt. When another condition occurs that generates an interrupt, the bit corresponding to the earlier masked non-fatal interrupt is still set.

A related situation to interrupt stacking is when two interrupts occur simultaneously. Since stacking does not occur until the SIP or DIP bits are set, there is a small timing window in which multiple interrupts can occur but are not stacked. These could be multiple SCSI interrupts (SIP set), multiple DMA interrupts (DIP set), or multiple SCSI and multiple DMA interrupts (both SIP and DIP set).

As previously mentioned, DMA interrupts do not attempt to flush the FIFOs before generating the interrupt. It is important to set either the Clear DMA FIFO (CLF) and Clear SCSI FIFO (CSF) bits if a DMA interrupt occurs, and the DMA FIFO Empty (DFE) bit is not set because any future SCSI interrupts are not posted until the DMA FIFO is clear of data. These “locked out” SCSI interrupts are posted as soon as the DMA FIFO is empty.

### **Halting in an Orderly Fashion**

When an interrupt occurs, the SYM53C876 attempts to halt in an orderly fashion.

- ▮ If the interrupt occurs in the middle of an instruction fetch, the fetch is completed, except in the case of a Bus Fault. Execution does not begin, but the DSP points to the next instruction since it is updated when the current instruction is fetched.
- ▮ If the DMA direction is a write to memory and a SCSI interrupt occurs, the SYM53C876 attempts to flush the DMA FIFO to memory before halting. Under any other circumstances only the current cycle is completed before halting, so the DFE bit in DSTAT should be checked to see if any data remains in the DMA FIFO.
- ▮ SCSI SREQ/SACK handshakes that have begun are completed before halting.
- ▮ The SYM53C876 attempts to clean up any outstanding synchronous offset before

halting.

- In the case of Transfer Control Instructions, once instruction execution begins it continues to completion before halting.
- If the instruction is a JUMP/CALL WHEN/IF <phase>, the DSP is updated to the transfer address before halting.
- All other instructions may halt before completion.

### **Sample Interrupt Service Routine**

The following is a sample of an interrupt service routine for the SYM53C876. It can be repeated if polling is used, or should be called when the INTA/ (or INTB/) pin is asserted if hardware interrupts are used.

1. Read ISTAT.
2. If the INTF bit is set, it must be written to a one to clear this status.
3. If only the SIP bit is set, read SIST0 and SIST1 to clear the SCSI interrupt condition and get the SCSI interrupt status. The bits in the SIST0 and SIST1 tell which SCSI interrupts occurred and determine what action is required to service the interrupts.
4. If only the DIP bit is set, read the DSTAT to clear the interrupt condition and get the DMA interrupt status. The bits in the DSTAT tells which DMA interrupts occurred and determine what action is required to service the interrupts.
5. If both the SIP and DIP bits are set, read SIST0, SIST1, and DSTAT to clear the SCSI and DMA interrupt condition and get the interrupt status. If using 8-bit reads of the SIST0, SIST1, and DSTAT registers to clear interrupts, insert a 12 CLK delay between the consecutive reads to ensure that the interrupts clear properly. Both the SCSI and DMA interrupt conditions should be handled before leaving the ISR. It is recommended that the DMA interrupt is serviced before the SCSI

interrupt, because a serious DMA interrupt condition could influence how the SCSI interrupt is acted upon.

6. When using polled interrupts, go back to step 1 before leaving the interrupt service routine, in case any stacked interrupts moved in when the first interrupt was cleared. When using hardware interrupts, the INTA/ (or INTB/) pin is asserted again if there are any stacked interrupts. This should cause the system to re-enter the interrupt service routine.

### **Chained Block Moves**

Since the SYM53C876 has the capability to transfer 16-bit wide SCSI data, a unique situation occurs when dealing with odd bytes. The chained move (CHMOV) SCRIPTS instruction along with the Wide SCSI Send (WSS) and Wide SCSI Receive (WSR) bits in the SCNTL2 register are used to facilitate these situations. The Chained Block Move instruction is illustrated in Figure 2-8.

### **Wide SCSI Send Bit**

The WSS bit is set whenever the SCSI controller is sending data (Data-Out for initiator or Data-In for target), and the controller detects a partial transfer at the end of a chained Block Move SCRIPTS instruction (this flag is not set if a normal Block Move instruction is used). Under this condition, the SCSI controller does not send the low-order byte of the last partial memory transfer across the SCSI bus. Instead, the low-order byte is temporarily stored in the lower byte of the SODL register and the WSS flag is set. The hardware uses the WSS flag to determine what behavior must occur at the start of the next data send transfer. When the WSS flag is set at the start of the next transfer, the first byte (the high-order byte) of the next data send transfer is “married” with the stored low-order byte in the SODL register; and the two bytes are sent out across the bus, regardless of the type of Block Move instruction (normal or chained). The flag is automatically



cleared when the “married” word is sent. The flag is alternately cleared through SCRIPTS or by the microprocessor. Also, the microprocessor or SCRIPTS can use this bit for error detection and recovery purposes.

### **Wide SCSI Receive Bit**

The WSR bit is set whenever the SCSI controller is receiving data (Data-In for initiator or Data-Out for target) and the controller detects a partial transfer at the end of a block move or chained block move SCRIPTS instruction. When WSR is set, the high order byte of the last SCSI bus transfer is not transferred to memory. Instead, the byte is temporarily stored in the SWIDE register. The hardware uses the WSR bit to determine what behavior must occur at the start of the next data receive transfer. The bit is automatically cleared at the start of the next data receive transfer. The bit can alternatively be cleared by the microprocessor or through SCRIPTS. Also, the microprocessor or SCRIPTS can use this bit for error detection and recovery purposes.

### **SWIDE Register**

This register is used to store data for partial byte data transfers. For receive data, the SWIDE register holds the high-order byte of a partial SCSI transfer that has not yet been transferred to memory. This stored data may be a residue byte (and therefore ignored) or it may be valid data that is transferred to memory at the beginning of the next Block Move instruction.

### **SODL Register**

For send data, the low-order byte of the SODL register holds the low-order byte of a partial memory transfer which has not yet been transferred across the SCSI bus. This stored data is usually “married” with the first

byte of the next data send transfer, and both bytes are sent across the SCSI bus at the start of the next data send block move command.

### **Chained Block Move SCRIPTS Instruction**

A chained Block Move SCRIPTS instruction primarily transfers consecutive data send or data receive blocks. Using the chained block move instruction facilitates partial receive transfers and allows correct partial send behavior without additional op code overhead. Behavior of the chained Block Move instruction varies slightly for sending and receiving data.

For receive data (Data-In for initiator or Data-Out for target), a chained Block Move instruction indicates that if a partial transfer occurred at the end of the instruction, the WSR flag is set. The high order byte of the last SCSI transfer is stored in the SWIDE register rather than transferred to memory. The contents of the SWIDE register should be the first byte transferred to memory at the start of the chained block move data stream. Since the byte count always represents data transfers to/from memory (as opposed to the SCSI bus), the byte transferred out of the SWIDE register is one of the bytes in the byte count. If the WSR bit is clear when a receive data chained Block Move instruction is executed, the data transfer occurs similar to that of the regular block move instruction. Whether the WSR bit is set or clear, when a normal block move instruction is executed, the contents of the SWIDE register is ignored and the transfer takes place normally. For “N” consecutive wide data receive Block Move instructions, the 2nd through the Nth Block Move instructions should be chained block moves.

For send data (Data-Out for initiator or Data-In for target), a chained Block Move instruction indicates that if a partial transfer terminates the chained block move instruction, the last low-order byte (the partial memory trans-

Functional Description  
**SCSI Functional Description**

fer) should be stored in the lower byte of the SODL register and not sent across the SCSI bus. Without the chained block move instruction, the last low-order byte would be sent across the SCSI bus. The starting byte count represents data bytes transferred from memory but not to the SCSI bus when a partial transfer exists. For example, if the instruction is an Initiator chained Block Move Data Out of five bytes (and WSS is not previously set), five bytes is transferred out of memory to the SCSI controller, four bytes is transferred from the SCSI controller across the SCSI bus, and one byte is temporarily stored in the lower byte of the SODL register waiting to be married with the first

byte of the next block move instruction. Regardless of whether a chained Block Move or normal Block Move instruction is used, if the WSS bit is set at the start of a data send command, the first byte of the data send command is assumed to be the high-order byte and is “married” with the low-order byte stored in the stored in the lower byte of the SODL register before the two bytes are sent across the SCSI bus. For “N” consecutive wide data send Block Move commands, the first through the (Nth - 1) Block Move instructions should be Chained Block Moves.

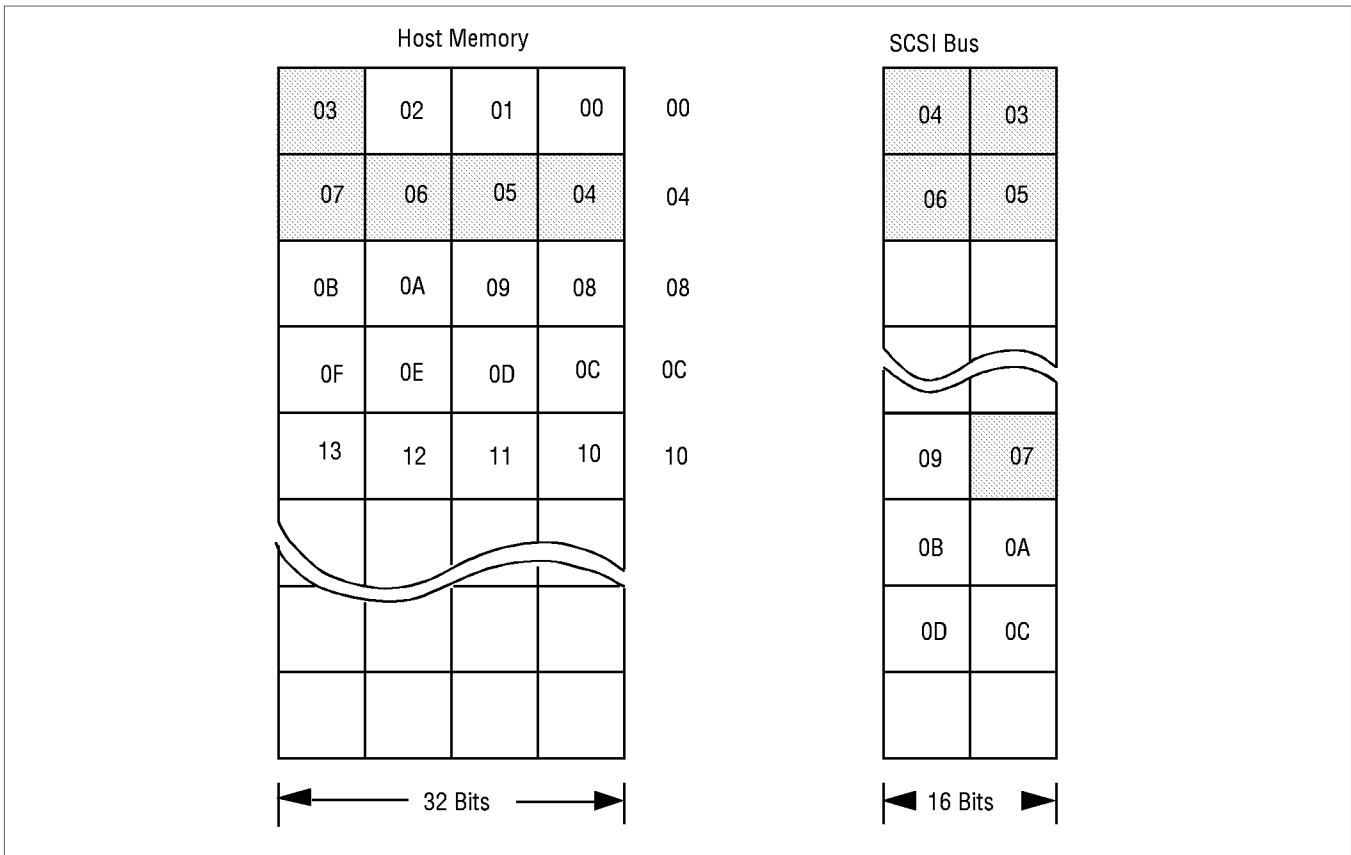

*Notes: CHMOV 5, 3 when DATA\_OUT: Moves five bytes from address 03 in the host memory to the SCSI bus (bytes 03, 04, 05, and 06 are moved and byte 07 remains in the low order byte of the SCSI Output Data Latch register and is married with the first byte of the following MOVE instruction)*

*MOVE 5, 9 when DATA\_OUT: Moves five bytes from address 09 in the host memory to the SCSI bus.*

**Figure 2-8: Block Move and Chained Block Move Instructions**

## Parallel ROM Interface

The SYM53C876 supports up to one megabyte of external memory in binary increments from 16 KB, to allow the use of expansion ROM for add-in PCI cards. Both functions of the device share the ROM interface. This interface is designed for low-speed operations such as downloading instruction code from ROM; it is not intended for dynamic activities such as executing instructions.

System requirements include the SYM53C876, two or three external 8-bit address holding registers (HCT273 or HCT374), and the appropriate memory device. The 4.7 K $\Omega$  pull-down resistors on the MAD bus require HC or HCT external components to be used. If in-system Flash ROM updates are required, a 7406 (high voltage open collector inverter), an MTD4P05, and several passive components are also needed. The memory size and speed is determined by pull-down resistors on the 8-bit bidirectional memory bus at power-up. The SYM53C876 senses this bus shortly after the release of the Reset signal and configures the ROM Base Address register and the memory cycle state machines for the appropriate conditions.

The external memory interface works with a variety of ROM sizes and speeds. An example set of interface drawings is in Appendix C.

The SYM53C876 supports a variety of sizes and speeds of expansion ROM, using pull-down resistors on the MAD(3-0) pins. The encoding of pins MAD(3-1) allows the user to define how much external memory is available to the SYM53C876. Table 2-5 shows the memory space associated with the possible values of MAD(3-1). The MAD(3-1) pins are fully defined in Chapter 3, *Signal Descriptions*.

**Table 2-5: Parallel ROM Support**

MAD(3-1)	Available Memory Space
000	16 KB
001	32 KB
010	64 KB
011	128 KB
100	256 KB
101	512 KB
110	1024 KB
111	no external memory present

To use one of the configurations mentioned above in a host adapter board design, put 4.7 K $\Omega$  pull-down resistors on the MAD pins corresponding to the available memory space. For example, to connect to a 32 KB external ROM, use pull-downs on MAD(3) and MAD(2). If the external memory interface is not used, then no external resistors are necessary since there are internal pull-ups on the MAD bus. The internal pull-up resistors are disabled when external pull-down resistors are detected, to reduce current drain.

The SYM53C876 allows the system to determine the size of the available external memory using the Expansion ROM Base Address register in PCI configuration space. For more information on how this works, refer to the PCI specification or the Expansion ROM Base Address register description in Chapter 4, *Registers*.

MAD(0) is the slow ROM pin. When pulled down, it enables two extra clock cycles of data access time to allow use of slower memory devices. The external memory interface also supports updates to flash memory.

## Serial EEPROM Interface

The SYM53C876 implements an interface that allows attachment of a serial EEPROM device to the GPIO0 and GPIO1 pins for each SCSI function. There are several modes of operation. These relate to the serial EEPROM and the Subsystem ID register and Subsystem Vendor ID register for each SCSI function. These modes are programmable through the MAD6 and MAD7 pins which are sampled at power-up or hard reset.

### Mode A Operation

No pulldown on MAD6, no pulldown on MAD7. In this mode, GPIO0 is the serial data signal (SDA) and GPIO1 is the serial clock signal (SCL). Certain data in the serial EEPROM is automatically loaded into chip registers at power-up or hard reset.

The format of the serial EEPROM data is defined in Table 2-6. If the EEPROM is not present, or the checksum fails, the Subsystem ID and Subsystem Vendor ID registers read back all zeros. At power-up or hard reset, only five bytes are loaded into the chip from locations 00h through 04h.

The Subsystem ID and Subsystem Vendor ID registers are read only, in accordance with the PCI specification, with a default value of all zeros.

**Table 2-6: Mode A Serial EEPROM data format**

Byte	Name	Description
00h	SVID(0)	Subsystem Vendor ID, LSB. This byte is loaded into the least significant byte of the Subsystem Vendor ID register in the appropriate PCI configuration space at chip power-up or hard reset.
01h	SVID(1)	Subsystem Vendor ID, MSB. This byte is loaded into the most significant byte of the Subsystem Vendor ID register in the appropriate PCI configuration spaces at chip power-up or hard reset.
02h	SID(0)	Subsystem ID, LSB. This byte is loaded into the least significant byte of the Subsystem ID register in the appropriate PCI configuration space at chip power-up or hard reset.
03h	SID(1)	Subsystem ID, MSB. This byte is loaded into the most significant byte of the Subsystem ID register in the appropriate PCI configuration space at chip power-up or hard reset.
04h	CKSUM	Checksum. This 8-bit checksum is formed by adding, byte-wise, each byte contained in locations 00h-03h to the seed value 55h, and then taking the 2's complement of the result.
05h-FFh	rsv	Reserved.
100h-EOM	UD	User Data.

## Mode B Operation

A 4.7K pulldown on MAD6, no pulldown on MAD7.

In this mode, GPIO0 and GPIO1 are each defined as either the serial data signal (SDA) or the serial clock signal (SCL), since both pins are controlled through software.

No data is automatically loaded into chip registers at power-up or hard reset. The Subsystem ID register and Subsystem Vendor ID register are read/write, in violation of the PCI specification, with a default value of all zero's.

## Mode C Operation

A 4.7K pulldown on MAD6, and a 4.7K pulldown on MAD7.

In this mode, GPIO1 is the serial data signal (SDA) and GPIO0 is the serial clock signal (SCL). Certain data in the serial EEPROM is automatically loaded into chip registers at power-up or hard reset.

The format of the serial EEPROM data is defined in Table 2-7. If the EEPROM is not present, or the checksum fails, the Subsystem ID (SID) and Subsystem Vendor ID (SVID) registers read back all zeros. At power-up or hard reset, only five bytes are loaded into the chip from locations FBh through FFh.

The SID and SVID registers are read only, in accordance with the PCI specification, with a default value of all zeros.

Before implementing Mode C, contact Symbios Logic for additional information.

**Table 2-7: Mode C Serial EEPROM data format**

Byte	Name	Description
00h-FAh	UD0	User Data
FBh	SVID(0)	Subsystem Vendor ID, LSB. This byte is loaded into the least significant byte of the Subsystem Vendor ID register in the appropriate PCI configuration space at chip power-up or hard reset.
FCh	SVID(1)	Subsystem Vendor ID, MSB. This byte is loaded into the most significant byte of the Subsystem Vendor ID register in the appropriate PCI configuration spaces at chip power-up or hard reset.
FDh	SID(0)	Subsystem ID, LSB. This byte is loaded into the least significant byte of the Subsystem ID register in the appropriate PCI configuration space at chip power-up or hard reset.
FEh	SID(1)	Subsystem ID, MSB. This byte is loaded into the most significant byte of the Subsystem ID register in the appropriate PCI configuration space at chip power-up or hard reset.
FFh	CKSUM	Checksum. This 8-bit checksum is formed by adding, bitwise, each byte contained in locations 00h-03h to the seed value 55h, and then taking the 2's complement of the result.
100h-EOM	UD	User Data.

---

## Mode D Operation

No pulldown on MAD6, and a 4.7K pull-down on MAD7. The Subsystem ID (SID) and the Subsystem Vendor ID are automati-

cally set to 1000h. This allows the OEM to have a non-zero value in the registers without requiring a serial EEPROM on the board.

## Power Management

The SYM53C876E complies with the PCI Bus Power Management Interface Specification, Revision 1.0. The PCI Function Power States are defined in that specification: D0, D1, D2, and D3. D0 is the maximum powered state, and D3 is the minimum powered state. Power state D3 is further categorized as D3hot or D3cold.

The SYM53C876E power states are independently controlled through two power state bits that are located in the PCI Configuration Space Register 44h.

**Table 2-8: Power States**

Config. Reg 44h Bits	Power State	Function
00	D0	Maximum Power
01	D1	Disables SCSI clock
10	D2	Coma Mode
11	D3	Minimum Power

Although the PCI Bus Power Management Interface Specification does not allow power state transitions D2 ---> D1, D3 ---> D2, or D3 ---> D1, the SYM53C876E hardware places no restriction on transitions between power states.

As the device transitions from one power level to a lower one, the attributes that occur from the higher power state level are carried over into the lower power state level. For example, D1 disables the SCSI CLK. Therefore, D2 will include this attribute as well as the attributes defined in the Power State D2 section. The PCI Function Power States--D0, D1, D2, and D3--are described below in conjunction with each SCSI function. Power state actions are separate for each function.

### Power State D0

Power state D0 is the maximum power state and is the power-up default state for each function.

### Power State D1

Power state D1 is a lower power state than D0. A function in this state is considered to be in snooze mode and disables the SCSI CLK. In snooze mode, a SCSI reset does not generate an /IRQ signal. However, by setting the Wakeup Interrupt Enable bit (bit 3 in the SIEN1 register), then a SCSI reset generates an /IRQ signal, but SCSI CLK is still disabled.

### Power State D2

Power state D2 is a lower power state than D1. A function in this state is considered to be in coma mode. The following PCI Configuration Space command register enable bits are suppressed:

- I/O Space Enable
- Memory Space Enable
- Bus Mastering Enable
- SERR
- PERR

Thus, the function's memory and I/O spaces cannot be accessed, and the function cannot be a PCI bus master. Furthermore, SCSI & DMA interrupts are disabled when the function is in power state D2. If the function is transitioned from power state D2 to power state D1 or D0, the previous values of the PCI command register are restored. Also, any pending interrupts before the function entered power state D2 are asserted.

### Power State D3

Power state D3 is the minimum power state, which includes subsettings called D3hot and D3cold. D3hot allows the device to transition to



D0 via software. The SYM53C876E is considered to be in power state D3cold when power is removed from the device. D3cold can transition to D0 by applying Vcc and resetting the device.

Power state D3 is a lower power level than power state D2. A function in this state is considered to be in coma mode. Furthermore, the

function's soft reset is continually asserted while in power state D3, which clears all pending interrupts and tristates the SCSI bus. In addition, the function's PCI command register is cleared. If both SYM53C876E functions are placed in power state D3, the Phase Lock Loop (PLL) is disabled, which results in further power savings.



# Chapter 3 Signal Descriptions

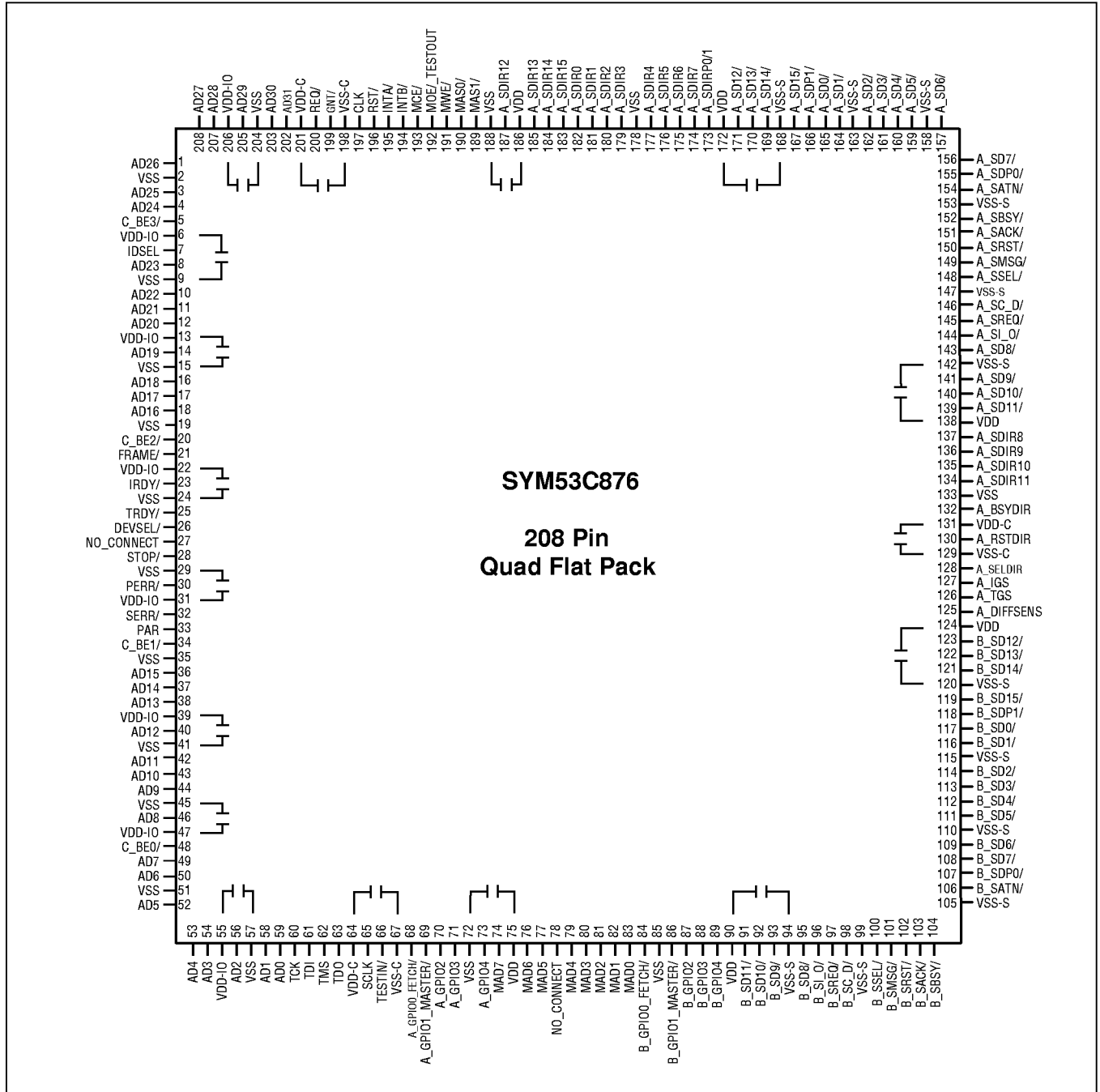
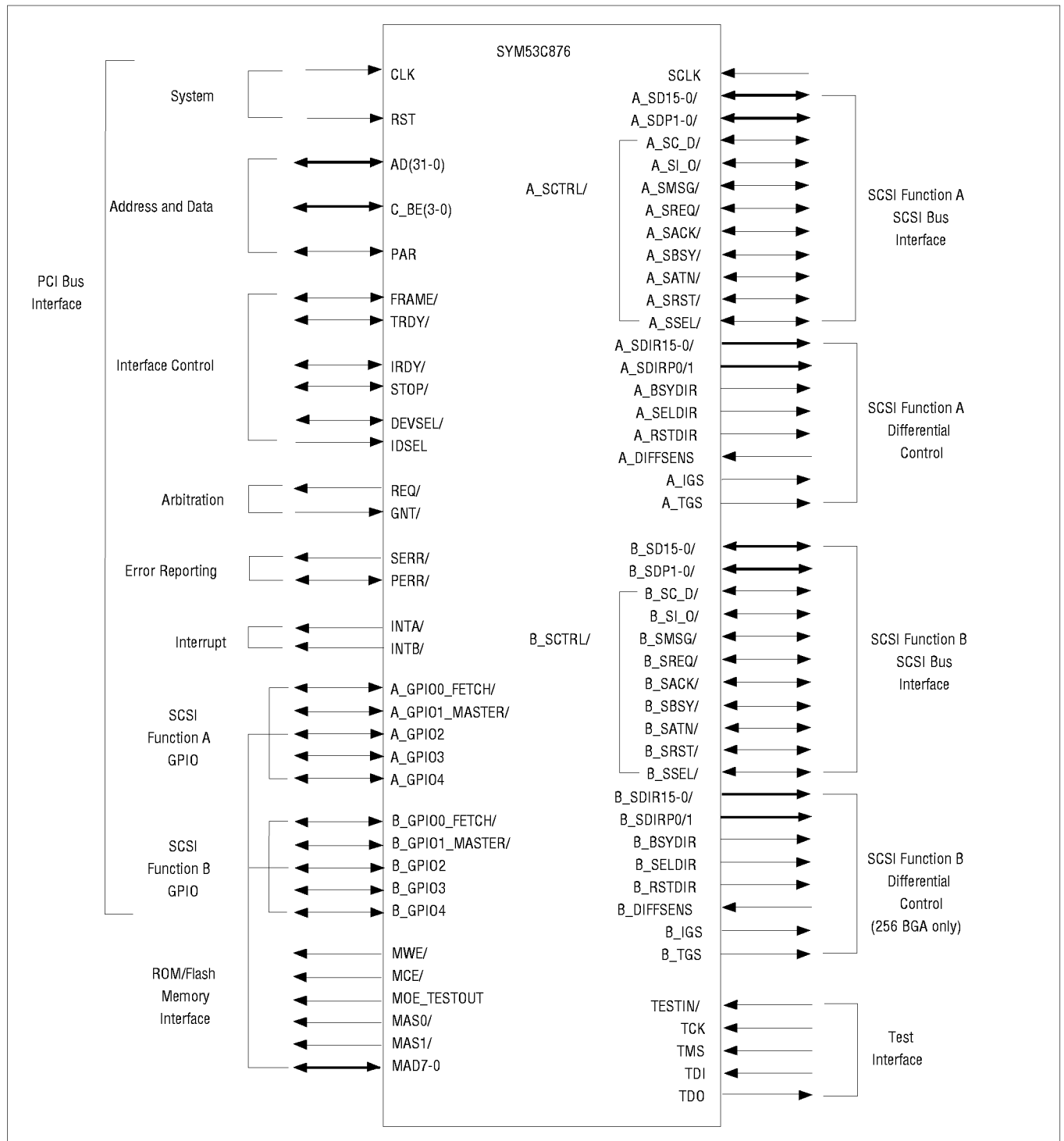

Figure 3-1: SYM53C876 208-Pin PQFP Diagram

	1	2	3	4	5	6	7	8	9	10	11	12	13	14	15	16	17	18	19	20
A	VSS	AD27	AD30	REQ/	RST/	MCE/	MWE/	B_IGS	B_SDIR13	VDD	A_SDIR13	A_SDIR0	A_SDIR4	A_SDIR7	A_SD12/	A_SDP1/	A_SD2/	A_SD3/	A_SD6/	A_SD7/
B	AD26	AD28	VDD-IO	AD31	GNT/	INTA/	MOE/_TO	MAS1/	VDD	A_SDIR12	A_SDIR15	A_SDIR1	A_SDIR5	A_DIRP0/1	A_SD13/	A_SD0/	A_SD4/	A_SD5/	A_SDP0/	A_SATN/
C	AD24	VSS	NC	AD29	VDD-C	VSS-C	INTB/	MAS0/	B_SDIR12	B_SDIR15	A_SDIR14	A_SDIR2	A_SDIR6	VDD	A_SD15/	A_SD1/	NC	NC	A_SBSY/	A_SRS7/
D	C_BE3/	AD25	NC	VSS	VSS	NC	CLK	VSS	B_TGS	B_SDIR14	NC	A_SDIR3	VSS	A_SD14/	NC	NC	VSS	NC	A_SMSG/	A_SC_D/
E	AD23	IDSEL	VDD-IO	NC	<b>SYM53C876</b>  <b>256-Ball</b> <b>Ball Grid Array</b>												A_SACK/	A_SSEL/	A_SREQ/	A_SD9/
F	AD21	AD22	VSS	NC													NC	A_SI_O/	A_SD10/	VDD
G	AD19	VDD-IO	AD20	NC													A_SD8/	A_SD11/	A_SDIR8	A_SDIR9
H	AD17	AD18	VSS	VSS													VSS	A_SDIR10	A_SDIR11	A_BSYDIR
J	FRAME/	C_BE2/	VSS	AD16													VDD-C	A_RSTDIR	VSS-C	A_SELDIR
K	VSS	VDD-IO	IRDY/	NC													A_IGS	A_TGS	A_DIFSEN	VDD
L	TRDY/	DEVSEL/	NC	STOP/													NC	B_SDIR1	B_SDIR2	B_SDIR0
M	VSS	PERR/	VDD-IO	SERR/													B_SDIR6	B_SDIR5	B_SDIR4	B_SDIR3
N	PAR	C_BE1/	VSS	VSS													VSS	VDD	B_DIRP0/1	B_SDIR7
P	AD15	AD14	VDD-IO	AD11													B_SD0/	B_SD14/	B_SD13/	B_SD12/
R	AD13	AD12	AD10	NC	NC	B_SD1/	B_SDP1/	B_SD15/												
T	VSS	AD9	AD8	NC	NC	B_SD4/	B_SD3/	B_SD2/												
U	VSS	VDD-IO	NC	VSS	VSS	NC	VDD-C	VSS	MAD7	NC	B_GPI00	B_GPI04	VSS	VDD	NC	B_SC_D/	VSS	NC	B_SD7/	B_SD5
V	C_BE0/	AD7	NC	AD2	TCK	TDO	VSS-C	A_GPI02	VDD	MAD4	MAD0	B_GPI03	B_RSTDIR	B_SDIR9	B_SD11/	B_SD8/	B_SSEL/	NC	B_SDP0/	B_SD6/
W	AD6	VSS	AD4	VDD-IO	TDI	SCLK	A_GPI00	A_GPI03	MAD6	NC	MAD1	B_GPI02	B_SELDIR	B_SDIR11	B_SDIR8	B_SD10/	B_SI_O/	B_SMSG/	B_SACK/	B_SATN/
Y	AD5	AD3	AD1	AD0	TMS	TESTIN/	A_GPI01	A_GPI04	MAD5	MAD3	MAD2	B_GPI01	VDD	B_BSYDIR	B_SDIR10	B_DIFSEN	B_SD9/	B_SREQ/	B_SRS7/	B_SBSY/

**Figure 3-2: SYM53C876 256-Ball BGA Diagram (top view)**



**Figure 3-3: SYM53C876 Functional Signal Grouping**

The SYM53C876 signals are divided into three primary interfaces:

- PCI Interface
- SCSI Interface
- ROM/Flash Memory Interface

The PCI interface signals are organized into the following functional groups: System, Address and Data, Interface Control, Arbitration, Error Reporting, Interrupt, and GPIO. The SCSI interface signals are organized into the following functional groups: data and parity group and SCSI control group.

A slash (/) at the end of the signal name indicates that the active state occurs when the signal is at a low voltage. When the slash is absent, the signal is active at a high voltage.

There are four signal type definitions:

- I        Input, a standard input-only signal
- O        Totem Pole Output, a standard output driver
- I/O      Input and output (bi-directional)
- T/S      Tri-State, a bi-directional, tri-state input/output signal
- S/T/S   Sustained Tri-state, an active low tri-state signal owned and driven by one and only one agent at a time

---

## PCI Interface Pins

---

### System Pins

**Table 3-1: PCI Interface Pins**

Pin Name	Pin/Ball Number	Type	Strength	Description
CLK	197, D7	I	N/A	<b>Clock</b> provides timing for all transactions on the PCI bus and is an input to every PCI device. All other PCI signals are sampled on the rising edge of CLK, and other timing parameters are defined with respect to this edge. Clock can optionally serve as the SCSI core clock, but this may effect Fast SCSI transfer rates.
RST/	196, A5	I	N/A	<b>Reset</b> forces the PCI sequencer of each device to a known state. All t/s and s/t/s signals are forced to a high impedance state, and all internal logic is reset. The RST/ input is synchronized internally to the rising edge of CLK. The CLK input must be active while RST/ is active to properly reset the device.

## Address/Data Pins

**Table 3-2: PCI Interface Pins**

Pin Name	Pin/Ball Number	Type	Strength	Description
AD(31-0)	202, 203, 205, 207, 208, 1, 3, 4, 8, 10, 11, 12, 14, 16, 17, 18, 36, 37, 38, 40, 42, 43, 44, 46, 49, 50, 52, 53, 54, 56, 58, 59 B4, A3, C4, B2, A2, B1, D2, C1, E1, F2, F1, G3, G1, H2, H1, J4, P1, P2, R1, R2, P4, R3, T2, T3, V2, W1, Y1, W3, Y2, V4, Y3, Y4	T/S	16 mA PCI	Physical longword <b>address and data</b> are multiplexed on the same PCI pins. During the first clock of a transaction, AD(31-0) contain a physical byte address. During subsequent clocks, AD(31-0) contain data. A bus transaction consists of an address phase followed by one or more data phases. PCI supports both read and write bursts. AD(7-0) define the least significant byte, and AD(31-24) define the most significant byte.
C_BE/(3-0)	5, 20, 34, 48 D1, J2, N2, V1	T/S	16 mA PCI	Bus <b>command and byte enables</b> are multiplexed on the same PCI pins. During the address phase of a transaction, C_BE/(3-0) define the bus command. During the data phase, C_BE/(3-0) are used as byte enables. The byte enables determine which byte lanes carry meaningful data. C_BE/(0) applies to byte 0, and C_BE/(3) to byte 3.
PAR	33, N1	T/S	16 mA PCI	<b>Parity</b> is the even parity bit that protects the AD(31-0) and C_BE/(3-0) lines. During address phase, both the address and command bits are covered. During data phase, both data and byte enables are covered.



## Interface Control Pins

Table 3-3: PCI Interface Pins

Pin Name	Pin/Ball Number	Type	Strength	Description
FRAME/	21, J1	S/T/S	16 mA PCI	<b>Cycle Frame</b> is driven by the current master to indicate the beginning and duration of an access. FRAME/ is asserted to indicate that a bus transaction is beginning. While FRAME/ is deasserted, either the transaction is in the final data phase or the bus is idle.
TRDY/	25, L1	S/T/S	16 mA PCI	<b>Target Ready</b> indicates the target agent's (selected device's) ability to complete the current data phase of the transaction. TRDY/ is used with IRDY/. A data phase is completed on any clock when used with IRDY/. A data phase is completed on any clock when both TRDY/ and IRDY/ are sampled asserted. During a read, TRDY/ indicates that valid data is present on AD(31-0). During a write, it indicates that the target is prepared to accept data. Wait cycles are inserted until both IRDY/ and TRDY/ are asserted together.
IRDY/	23, K3	S/T/S	16 mA PCI	<b>Initiator Ready</b> indicates the initiating agent's (bus master's) ability to complete the current data phase of the transaction. IRDY/ is used with TRDY/. A data phase is completed on any clock when both IRDY/ and TRDY/ are sampled asserted. During a write, IRDY/ indicates that valid data is present on AD(31-0). During a read, it indicates that the master is prepared to accept data. Wait cycles are inserted until both IRDY/ and TRDY/ are asserted together.
STOP/	28, L4	S/T/S	16 mA PCI	<b>Stop</b> indicates that the selected target is requesting the master to stop the current transaction.
DEVSEL/	26, L2	S/T/S	16 mA PCI	<b>Device Select</b> indicates that the driving device has decoded its address as the target of the current access. As an input, it indicates to a master whether any device on the bus has been selected.
IDSEL	7, E2	I	N/A	<b>Initialization Device Select</b> is used as a chip select in place of the upper 24 address lines during configuration read and write transactions.

## Arbitration Pins

**Table 3-4: PCI Interface Pins**

Pin Name	Pin/Ball Number	Type	Strength	Description
REQ/	200, A4	O	16 mA PCI	<b>Request</b> indicates to the system arbiter that this agent desires use of the PCI bus. Both SCSI functions share the GNT/ signal.
GNT/	199, B5	I	N/A	<b>Grant</b> indicates to the agent that access to the PCI bus has been granted. Both SCSI functions share the GNT/ signal.

## Error Recording Pins

**Table 3-5: PCI Interface Pins**

Pin Name	Pin/Ball Number	Type	Strength	Description
PERR/	30, M2	S/T/S	16 mA PCI	<b>Parity Error</b> may be pulsed active by an agent that detects a data parity error. PERR/ can be used by any agent to signal data corruption. However, on detection of a PERR/ pulse, the central resource may generate a non-maskable interrupt to the host CPU, which often implies the system is unable to continue operation once error processing is complete.
SERR/	32, M4	O	16 mA PCI	This open drain output is used to report address parity errors.

## PCI Interrupt Pins

**Table 3-6: PCI Interrupt Pins**

Pin Name	Pin/Ball Number	Type	Strength	Description
INTA/	195, B6	O	16 mA PCI	<b>Interrupt Function A.</b> This signal, when asserted low, indicates that an interrupting condition in SCSI Function A and that service is required from the host CPU. The output drive of this pin is open drain with an internal weak pull-up. If the SCSI Function B interrupt is rerouted at power up via the INTA/ enable sense resistor (pulldown on MAD4), then this signal indicates an interrupt in either SCSI Function A or SCSI Function B.
INTB/	194, C7	O	16 mA PCI	<b>Interrupt Function B.</b> This signal, when asserted low, indicates an interrupting condition in SCSI Function B and that service is required from the host CPU. The output drive of this pin is open drain with an internal weak pull-up. This interrupt can be rerouted at powerup via the INTA/ enable sense resistor (pull-down on MAD4). This causes the SYM53C876 to program the SCSI Function B PCI register Interrupt Pin (3D) to 01h.

## GPIO Interface Pins

**Table 3-7: GPIO Interface Pins**

Pin Name	Pin/Ball Number	Type	Strength	Description
A_GPIO0_ FETCH/	68, W7	I/O	16 mA	<b>SCSI Function A General Purpose I/O pin 0.</b> Optionally, when driven low, indicates that the next bus request is for an op code fetch. This pin is programmable at powerup through the MAD(7-6) pins to serve as either the data or clock signal for the serial EEPROM interface.
B_GPIO0_ FETCH/	84, U11	I/O	16 mA	<b>SCSI Function B General Purpose I/O pin 0.</b> Optionally, when driven low, indicates that the next bus request is for an op code fetch. This pin is programmable at powerup through the MAD(7-6) pins to serve as either the data or clock signal for the serial EEPROM interface.
A_GPIO1_ MASTER/	69, Y7	I/O	16 mA	<b>SCSI Function A General purpose I/O pin 1.</b> Optionally, when driven low, indicates that the SYM53C876 is bus master. This pin is programmable at powerup through the MAD(7-6) pins to serve as either the data or clock signal for the serial EEPROM interface.
B_GPIO1_ MASTER/	86, Y12	I/O	16 mA	<b>SCSI Function B General purpose I/O pin 1.</b> Optionally, when driven low, indicates that the SYM53C876 is bus master. This pin is programmable at powerup through the MAD(7-6) pins to serve as either the data or clock signal for the serial EEPROM interface.
A_GPIO2	70, V8	I/O	16 mA	<b>SCSI Function A General Purpose I/O pin 2.</b> This pin is a general purpose I/O pin that powers up as an input.
B_GPIO2	87, W12	I/O	16 mA	<b>SCSI Function B General purpose I/O pin 2.</b> B_GPIO2 powers up as an input.
A_GPIO3	71, W8	I/O	16 mA	<b>SCSI Function A General purpose I/O pin 3.</b> A_GPIO3 powers up as an input. Currently our drivers, use A_GPIO3 as a means to detect Diffsense.
B_GPIO3	88, V12	I/O	16 mA	<b>SCSI Function B General purpose I/O pin 3.</b> B_GPIO3 powers up as an input. Currently our drivers, use B_GPIO3 as a means to detect Diffsense.
A_GPIO4	73, Y8	I/O	16 mA	<b>SCSI Function A General purpose I/O pin 4.</b> A_GPIO4 powers up as an output. It can be used as the enable line for VPP, the 12 Volt power supply to the external flash memory interface.
B_GPIO4	89, U12	I/O	16 mA	<b>SCSI Function B General purpose I/O pin 4.</b> B_GPIO4 powers up as an output. It can be used as the enable line for VPP, the 12 Volt power supply to the external flash memory interface.

# SCSI Interface Pins

**Table 3-8: SCSI Interface Pins**

Pin Name	Pin/Ball Number	Type	Strength	Description
SCLK	65, W6	I	N/A	<b>SCSI Clock</b> is used to derive all SCSI-related timings. The speed of this clock is determined by the applications requirements. In some applications, SCLK is sourced internally from the PCI bus clock (CLK). If SCLK is internally sourced, tie the SCLK pin low. For Ultra SCSI operations, the clock supplied to SCLK must be at 40 MHz. This frequency is doubled to create the 80 MHz clock required by both SCSI functions.
A_SD/(15-0), A_SDP/(1-0)	167, 169, 170, 171, 139, 140, 141, 143, 156, 157, 159, 160, 161, 162, 164, 165, 166, 155, C15, D14, B15, A15, G18, F19, E20, G17, A20, A19, B18, B17, A18, A17, C16, B16, A16, B19	I/O	48 mA SCSI	<b>SCSI Function A Data</b> includes the following data lines and parity signals: A_SD/(15-0) (16-bit SCSI data bus), and A_SDP/(1-0) (SCSI data parity bits).
B_SD/(15-0), B_SDP/(1-0)	119, 121, 122, 123, 91, 92, 93, 95, 108, 109, 111, 112, 113, 114, 116, 117, 118, 107, R20, P18, P19, P20, V15, W16, Y17, V16, U19, V20, U20, T18, T19, T20, R18, P17, R19, V19	I/O	48 mA SCSI	<b>SCSI Function B Data</b> includes the following data lines and parity signals: B_SD/(15-0) (16-bit SCSI data bus), and B_SDP/(1-0) (SCSI data parity bits).

**Table 3-8: SCSI Interface Pins**

A_SCTRL/	146, 144, 149, 145, 151, 152, 154, 150, 148, D20, F18, D19, E19, E17, C19, B20, C20, E18	I/O	48 mA SCSI	<p><b>SCSI Function A Control</b> includes the following signals:</p> <p><b>A_SC_D/</b> - SCSI phase line, command/data</p> <p><b>A_SI_O/</b> - SCSI phase line, input/output</p> <p><b>A_SMSG/</b> - SCSI phase line, message</p> <p><b>A_SREQ/</b> - Data handshake line from target device</p> <p><b>A_SACK/</b> - Data handshake signal from initiator device</p> <p><b>A_SBSY/</b> - SCSI bus arbitration signal, busy</p> <p><b>A_SATN/</b> - SCSI Attention, the initiator is requesting a message out phase</p> <p><b>A_SRST/</b> - SCSI bus reset</p> <p><b>A_SSEL/</b> - SCSI bus arbitration signal, select device</p>
B_SCTRL/	98, 96, 101, 97, 103, 104, 106, 102, 100, U16, W17, W18, Y18, W19, Y20, W20, Y19, V17	I/O	48 mA SCSI	<p><b>SCSI Function B Control</b> includes the following signals:</p> <p><b>B_SC_D/</b> - SCSI phase line, command/data</p> <p><b>B_SI_O/</b> - SCSI phase line, input/output</p> <p><b>B_SMSG/</b> - SCSI phase line, message</p> <p><b>B_SREQ/</b> - Data handshake line from target device</p> <p><b>B_SACK/</b> - Data handshake signal from initiator device</p> <p><b>B_SBSY/</b> - SCSI bus arbitration signal, busy</p> <p><b>B_SATN/</b> - SCSI Attention, the initiator is requesting a message out phase</p> <p><b>B_SRST/</b> - SCSI bus reset</p> <p><b>B_SSEL/</b> - SCSI bus arbitration signal, select device</p>

## Differential Control Pins

**Table 3-9: Differential Control Pins**

Pin Name	Pin/Ball Number	Type	Strength	Description
A_SDIR(15-0)	183, 184, 185, 187, 134, 135, 136, 137, 174, 175, 176, 177, 179, 180, 181, 182, B11, C11, A11, B10, H19, H18, G20, G19, A14, C13, B13, A13, D12, C12, B12, A12	O	4 mA	Driver direction control for SCSI Function A data lines.
A_SDIRP0/1	173, B14	O	4 mA	Driver direction control for SCSI Function A parity line.
A_BSYDIR	132, H20	O	4 mA	Driver enable control for SCSI Function A SBSY/signal.

**Table 3-9: Differential Control Pins**

A_SELDIR	128, J20	O	4 mA	Driver enable control for SCSI Function A SSEL/ signal.
A_RSTDIR	130, J18	O	4 mA	Driver enable control for SCSI Function A SRST/ signal.
A_DIFFSENS	125, K19	I	N/A	<b>SCSI Function A Differential Sense.</b> This pin detects the presence of a single-ended device on a differential system. When external differential transceivers are used, and a zero is detected on this pin, all SCSI Function A chip outputs are tri-stated to avoid damage to the transceivers. Tie this pin high during single-ended operation. The normal value of this pin is one.
A_TGS	126, K18	O	4 mA	SCSI Function A direction control for target driver group.
A_IGS	127, K17	O	4 mA	SCSI Function A direction control for initiator driver group.
B_SDIR(15-0)	C10, D10, A9, C9, W14, Y15, V14, W15, N20, M17, M18, M19, M20, L19, L18, L20	O	4 mA	Driver direction control for SCSI Function B data lines.
B_SDIRP0/1	N19	O	4 mA	Driver direction control for SCSI Function B parity line.
B_BSYDIR	Y14	O	4 mA	Driver enable control for SCSI Function B SBSY/ signal.
B_SELDIR	W13	O	4 mA	Driver enable control for SCSI Function B SSEL/ signal.
B_RSTDIR	V13	O	4 mA	Driver enable control for SCSI Function B SRST/ signal.
B_DIFFSENS	Y16	I	N/A	<b>SCSI Function B Differential Sense.</b> This pin detects the presence of a single-ended device on a differential system. When external differential transceivers are used, and a zero is detected on this pin, all SCSI Function B chip outputs are tri-stated to avoid damage to the transceivers. Tie this pin high during single-ended operation. The normal value of this pin is one.
B_TGS	D9	O	4 mA	SCSI Function B direction control for target driver group.



**Table 3-9: Differential Control Pins**

---

B_IGS	A8	O	4 mA	SCSI Function B direction control for initiator driver group.
-------	----	---	------	---

---

## ROM/Flash Interface Pins

Table 3-10: ROM/Flash Interface Pins

Pin Name	Pin/Ball Number	Type	Strength	Description
MAS0/	190, C8	O	4 mA	<b>Memory Address Strobe 0.</b> This pin can latch in the least significant address byte of an external EPROM or flash memory. Since the SYM53C876E moves addresses eight bits at a time, this pin connects to the clock of an external bank of flip-flops which are used to assemble up to a 20-bit address for the external memory. If an external memory requires more than 16 bits of addressing as specified by the pulldown resistors at power up and bit 0 in the expansion ROM Base Address register, see the External Memory Interface diagram for proper usage.
MAS1/	189, B8	O	4 mA	<b>Memory Address Strobe 1.</b> This pin can latch in the address byte corresponding to address bits 15-8 of an external EPROM or flash memory. Since the SYM53C876E moves addresses eight bits at a time, this pin connects to the clock of an external bank of flip-flops which assemble up to a 20-bit address for the external memory. If an external memory requires more than 16 bits of addressing as specified by the pulldown resistors at power up and bit 0 in the expansion ROM Base Address register, see the External Memory Interface diagram for proper usage.
MAD7-0	74, 76, 77, 79, 80, 81, 82, 83, U9, W9, Y9, V10, Y10, Y11, W11, V11	I/O	4 mA	<b>Memory Address/Data Bus.</b> This bus is used in conjunction with the memory address strobe pins and external address latches to assemble up to a 20-bit address for an external EPROM or flash memory. This bus puts out the least significant byte first and finishes with the most significant bits. It is also used to write data to a flash memory or read data into the chip from external EPROM/flash memory. All MAD pins have internal pull-up resistors.
MWE/	191, A7	O	4 mA	<b>Memory Write Enable.</b> This pin is used as a write enable signal to an external flash memory.
MOE/_TESTOUT	192, B7	O	4 mA	<b>Memory Output Enable.</b> This pin is used as an output enable signal to an external EPROM or flash memory during read operations. It is also used to test the connectivity of the SYM53C876E signals in the “AND-tree” test mode. This pin is only driven as the Test Out function when the TESTIN/ pin is driven low.
MCE/	193, A6	O	4 mA	<b>Memory Chip Enable.</b> This pin is used as a chip enable signal to an external EPROM or flash memory device.

---

## Test Pins

**Table 3-11: Test Pins**

Pin Name	Pin/Ball Number	Type	Strength	Description
MOE/_TESTOUT	192, B7	O	4 mA	<b>Test Out.</b> This pin can test the connectivity of the SYM53C876E signals in the “AND-tree” test mode. It is also used as an output enable signal to an external EPROM or flash memory during read operations. This pin is only driven as the Test Out function when the TESTIN/ pin is driven low.

Table 3-11: Test Pins

TESTIN/	66, Y6	I	N/A	<b>Test In.</b> When this pin is driven low, the SYM53C876E connects all inputs and outputs to an “AND tree”. The SCSI control signals and data lines are not connected to the tree. The output of the “AND tree” is connected to the Test Out pin (MOE/_TESTOUT). When the TESTIN/ pin is driven low internal pull-ups are enabled on all input, output, and bidirectional pins; all output and bidirectional pins signals are tri-stated; and the MOE/_TESTOUT pin is enabled. Connectivity is tested by driving one of the SYM53C876E pins low. The MOE/_TESTOUT should respond by also driving low.
TCK	60, V5	I	N/A	<b>Test Clock.</b> This pin provides the clock for the JTAG test logic. It has a static pull-up.
TMS	62, Y5	I	N/A	The signal received at TMS is decoded by the TAP controller to control JTAG test operations. It has a static pull-up.
TDI	61, W5	I	N/A	<b>Test Data In.</b> Serial test instructions are received by the JTAG test logic at this pin. It has a static pull-up.

**Table 3-11: Test Pins**

TDO	63, V6	O	N/A	<b>Test Data Out.</b> This pin is the serial output for test instructions and data from the JTAG test logic.
-----	--------	---	-----	--

## Power and Ground Pins

Table 3-12: Power and Ground Pins

Pin Name	Pin/Ball Number	Type	Strength	Description
V <sub>DD</sub> -IO	6, 13, 22, 31, 39, 47, 55, 206, B3, E3, G2, K2, M3, P3, U2, W4	P	N/A	Power for PCI bus drivers/receivers.
V <sub>SS</sub>	2, 9, 15, 19, 24, 29, 35, 41, 45, 51, 57, 204, A1, C2, D4, D5, D8, D13, D17, F3, H3, H4, H17, J3, K1, M1, N3, N4, N17, T1, U1, U4, U5, U8, U13, U17, W2	G	N/A	Ground for PCI bus drivers/receivers.
V <sub>DD</sub> -S	90, 124, 138, 172, A10, B9, C14, F20, K20, N18, U14, V9, Y13	P	N/A	Power for SCSI bus drivers/receivers.
V <sub>SS</sub> -S	94, 99, 105, 110, 115, 120, 142, 147, 153, 158, 163, 168	G	N/A	Ground for SCSI bus drivers/receivers.
V <sub>DD</sub> -C	64, 131, 201, C5, J17, U7	P	N/A	Power for core logic.
V <sub>SS</sub> -C	67, 129, 198, C6, J19, V7	G	N/A	Ground for core logic.
V <sub>DD</sub>	75, 186	P	N/A	Power for other I/O.
V <sub>SS</sub>	72, 85, 133, 178, 188	G	N/A	Ground for other I/O.

### Isolated Power Supplies

The I/O driver pad rows and digital core have isolated power supplies as delineated by the "I/O" and "CORE" extensions on their respective V<sub>SS</sub> and V<sub>DD</sub> names.

These power and ground pins should be connected directly to the primary power and ground planes of the circuit board. Bypass capacitors of 0.01µF should be applied between adjacent V<sub>SS</sub> and V<sub>DD</sub> pairs wherever possible. Do not connect bypass capacitors between V<sub>SS</sub> and V<sub>DD</sub> pairs that cross power and ground bus boundaries.

---

## MAD Bus Programming

The MAD(7-0) pins, in addition to serving as the address/data bus for the local memory interface, also are used to program power-up options for the chip. A particular option is programmed by connecting a 4.7 K $\Omega$  resistor between the appropriate MAD(x) pin and V<sub>SS</sub>. The pull-down resistors require that HC or HCT external components are used for the memory interface.

- MAD(7) Serial EEPROM programmable option. Please refer to the *Serial EEPROM Interface and Subsystem ID/Subsystem Vendor ID Operating Modes* section in Chapter 2 for details.
- MAD(6) Serial EEPROM programmable option. Please refer to the *Serial EEPROM Interface and Subsystem ID/Subsystem Vendor ID Operating Modes* section in Chapter 2 for details.
- MAD(5) Scripts RAM disable.
- MAD(4) INTA/ routing enable. Placing a pull-down resistor on this pin causes SCSI Function B interrupt requests to appear on the INTA/ pin, along with SCSI Function A interrupt requests, instead of on INTB/. Placing a pull-down resistor on this pin also causes the SCSI Function B interrupt pin register (3Dh) in PCI configuration space to be programmed to 01h instead of 02h.
- The MAD(3-1) pins are used to set the size of the external expansion ROM device attached. Encoding for these pins are listed in the following table (“0” indicates a pull-down resistor is

attached, “1” indicates no pull-down resistor attached).

**Table 3-13: Decode of MAD pins**

<b>MAD(3-1)</b>	<b>Available Memory Space</b>
000	16 KB
001	32 KB
010	64 KB
011	128 KB
100	256 KB
101	512 KB
110	1024 KB
111	no external memory present

- The MAD(0) pin is the slow ROM pin. When pulled down, it enables two extra cycles of data access time to allow use of slower memory devices.
- All MAD pins have internal pull-up resistors.



## Chapter 4 Registers

### PCI Configuration Registers

The PCI Configuration registers are accessed by performing a configuration read/write to the device with its IDSEL pin asserted and the appropriate value in AD(10:8) during the address phase of the transaction. SCSI Function A is identified by a binary value of 000b, and SCSI Function B by a value of 001b. Each SCSI channel contains the same register set with identical default values, except the Interrupt Pin register.

Table 4-1 shows the PCI configuration registers implemented by the SYM53C876.

All PCI-compliant devices, such as the SYM53C876, must support the Vendor ID, Device ID, Command, and Status Registers. Support of other PCI-compliant registers is optional. In the SYM53C876, registers that are not supported are not writable and return all zeroes when read. Only those registers and bits that are currently supported by the SYM53C876 are described in this chapter.

**Table 4-1: PCI-to-SCSI Configuration Register Map**

31	16	15	0	
Device ID		Vendor ID = 1000h		00h
Status		Command		04h
Class Code			Rev ID	08h
BIST	Header Type	Latency Timer	Cache Line Size	0Ch
Base Address Zero (I/O), SCSI Operating Registers				10h
Base Address One (Memory), SCSI Operating Registers				14h
Base Address Two (Memory) SCRIPTS RAM				18h
Not Supported				1Ch
Not Supported				20h
Not Supported				24h
Reserved				28h
Subsystem ID		Subsystem Vendor ID		2Ch
Expansion ROM Base Address				30h
Reserved			Capabilities Pointer	34h
Reserved				38h
Max_Lat	Min_Gnt	Interrupt Pin*	Interrupt Line	3Ch
Power Management Capabilities		Next Item Pointer	Capability ID	40h
Data	Bridge Support Ext	Pwr. Mgmt. Control/Status Register		44h

**Note:** Shaded areas are reserved or represent the SYM53C876E capabilities.

set with identical default values; one exception is the Interrupt Pin register and this is noted with an

“\*”.

---

**Register 00h**  
**Vendor ID**  
*Read Only*

VID	VID	VID	VID
15-12	11-8	7-4	3-0
Default >>>			
1	0	0	0

This field identifies the manufacturer of the device. The Symbios Logic Vendor ID is 1000h.

---

**Register 02h**  
**Device ID**  
*Read Only*

DID	DID	DID	DID
15-12	11-8	7-4	3-0
Default >>>			
0	0	0	F

This field identifies the particular device. The SYM53C876 Device ID is 000Fh.

**Register 04h**  
**Command**  
*Read/Write*

RES	SE	RES	EPER	RES	WIE	RES	EBM	EMS	EIS
15-9	8	7	6	5	4	3	2	1	0
Default >>>									
0	0	0	0	0	0	0	0	0	0

The SCSI Command Register provides coarse control over a device's ability to generate and respond to PCI cycles. When a zero is written to this register, the SYM53C876 is logically disconnected from the PCI bus for all accesses except configuration accesses.

**Bits 15-9 Reserved**

**Bit 8 SERR/ Enable(SE)**

This bit enables the SERR/ driver. SERR/ is disabled when this bit is clear. The default value of this bit is zero. Set this bit and bit 6 to report address parity errors. In SYM53C876E, this bit is suppressed in Power State D2.

**Bit 7 Reserved**

**Bit 6 Enable Parity Error Response (EPER)**

This bit allows a SCSI function of the SYM53C876E to detect parity errors on the PCI bus and report these errors to the system. Only data parity checking is enabled and disabled with this bit. The SYM53C876 always generates parity for the PCI bus. In SYM53C876E, this bit is suppressed in Power State D2.

**Bit 5 Reserved**

**Bit 4 Write and Invalidate Enable (WIE)**

This bit allows a SCSI function of the SYM53C876 to generate write and invalidate commands on the PCI bus. Set the WRIE bit in the CTEST3 register also for the SCSI function to generate write and invalidate commands.

**Bit 3 Reserved**

**Bit 2 Enable Bus Mastering (EBM)**

This bit controls the ability of a SCSI function to act as a master on the PCI bus. A value of zero disables this device from generating PCI bus master accesses. A value of one allows the SCSI function to behave as a bus master. When the SCSI function is a bus master it can fetch SCRIPTS instructions and transfer data. In SYM53C876E, this bit is suppressed in Power State D2.

**Bit 1 Enable Memory Space (EMS)**

This bit controls the ability of a SCSI function to respond to Memory space accesses. A value of zero disables the device response. A value of one allows a SCSI function of the SYM53C876 to respond to Memory Space accesses at the address range specified by the Base Address One and Base Address Two registers in the SCSI function's PCI configuration space. In SYM53C876E, this bit is suppressed in Power State D2.

**Bit 0 Enable I/O Space (EIS)**

This bit controls a SCSI function's response to I/O space accesses. A value of zero disables the device response. A value of one allows a SCSI function to respond to I/O Space accesses at the address range specified by the Base Address Zero register in the SCSI function's PCI configuration space. In SYM53C876E, this bit is suppressed in Power State D2.

**Register 06h**

Status

*Read/Write*

DPE	SSE	RMA	RTA	RES	DT	DPR	RES	NC	RES
15	14	13	12	11	10-9	8	7-5	4	3-0

Default >>>

0 0 0 0 0 0 0 0 1 0

Reads to this register behave normally. Writes are slightly different in that bits can be cleared, but not set. A bit is reset whenever the register is written, and the data in the corresponding bit location is a one. For instance, to clear bit 15 and not affect any other bits, write the value 8000h to the register.

**Bit 15 Detected Parity Error (DPE)  
 (from Slave)**

This bit is set by the a SCSI function of the SYM53C876 whenever it detects a data parity error, even if data parity error handling is disabled.

**Bit 14 Signaled System Error (SSE)**

This bit is set whenever the device asserts the SERR/ signal.

**Bit 13 Received Master Abort (RMA)  
 (from Master)**

A master device should set this bit whenever its transaction (except for Special Cycle) is terminated with Master Abort.

**Bit 12 Received Target Abort (RTA)  
 (from Master)**

A master device should set this bit whenever its transaction is terminated by target-abort.

**Bit 11 Reserved**

**Bits 10-9 DEVSEL/ Timing (DT)**

These bits encode the timing of DEVSEL/. These are encoded as 00b for fast, 01b for medium, 10b for slow, and 11b reserved. These bits are read-only and should indicate the slowest time that a device asserts DEVSEL/ for any bus command except Configuration Read and Configuration Write. In the SCSI functions of the SYM53C876, 01b is supported.

**Bit 8 Data Parity Reported(DPR)**

This bit is set when the following conditions are met:

1. The bus agent asserted PERR/ itself or observed PERR/ asserted;
2. The agent setting this bit acted as the bus master for the operation in which the error occurred;
3. The Parity Error Response bit in the Command Register is set.

**Bits 7-5 Reserved**

**Bit 4 New Capabilities (NC)**

This bit is set to indicate the presence of a list of extended capabilities such as PCI Power Management. This bit is Read Only.

**Bit 3-0 Reserved**

**Register 08h**  
**Revision ID**  
*Read Only*

RID	RID	RID	RID	RID	RID	RID	RID
7	6	5	4	3	2	1	0
Default >>>							
0	0	1	1	0	1	1	1

This field specifies device and revision identifiers. The value of this register is 00110111h or 37h.

**Register 09h**  
**Class Code**  
*Read Only*

CC	CC	CC	CC	CC	CC
23-20	19-16	15-12	11-8	7-4	3-0
Default >>>					
0	1	0	0	0	0

This register is used to identify the generic function of the device. The upper byte of this register is a base class code, the middle byte is a subclass code, and the lower byte identifies a specific register-level programming interface. The value of this register is 010000h, which identifies a SCSI controller.

**Register 0Ch**  
**Cache Line Size**  
*Read/Write*

CLS	CLS	CLS	CLS	CLS	CLS	CLS	CLS
7	6	5	4	3	2	1	0

Default >>>

0 0 0 0 0 0 0 0

This register specifies the system cache line size in units of 32-bit words. The value in this register is used by the device to determine whether to use Write and Invalidate or Write commands for performing write cycles, and whether to use Read, Read Line, or Read Multiple commands for performing read cycles as a bus master. Devices participating in the caching protocol use this field to know when to retry burst accesses at cacheline boundaries. These devices can ignore the PCI cache support lines (SDONE and SB0#) when this register is set to 0. If this register is programmed to a number which is not a power of 2, the device does not use PCI performance commands to perform data transfers.

**Register 0Dh**  
**Latency Timer**  
*Read/Write*

LT	LT	LT	LT	LT	LT	LT	LT
7	6	5	4	3	2	1	0

Default >>>

0 0 0 0 0 0 0 0

The Latency Timer register specifies, in units of PCI bus clocks, the value of the Latency Timer for this PCI bus master. The SCSI functions of the SYM53C876 support this timer. All eight bits are writable, allowing latency values of 0-255 PCI clocks. Use the following equation to calculate an optimum latency value for the SCSI functions of the SYM53C876.

$$\text{Latency} = 2 + (\text{Burst Size} * (\text{typical wait states} + 1))$$

Values greater than optimum are also acceptable.

**Register 0Eh**  
**Header Type**  
*Read Only*

HT 7-4	HT 3-0
Default >>> 8	0

This register identifies the layout of bytes 10h through 3Fh in configuration space and also whether or not the device contains multiple functions. Since the SYM53C876 is a multi-function controller, the value of this register is 80h.

**Register 0Fh**  
**BIST**  
*Read Only*

BIST Capable 7	Start BIST 6	RES 5-4	Completion Code 3-0
Default >>> 0	0	00	0000

This register is used for control and status of BIST. Since the SYM53C876 does not support BIST, this register is read-only and always returns a value of 00h.

**Register 10h****Base Address Zero (I/O)***Read/Write*

BAZ	BAZ	BAZ	BAZ	BAZ	BAZ	BAZ	BAZ
31-28	27-24	23-20	19-16	15-12	11-8	7-4	3-0

Default &gt;&gt;&gt;

X X X X X X X XXX1

This 32-bit register has bit zero hardwired to one. Bit 1 is reserved and returns a zero on all reads, and the other bits are used to map the device into I/O space. For detailed information on the operation of this register, refer to the PCI specification. This Base Address Zero register maps SCSI operating registers into I/O space.

**Register 14h****Base Address One (Memory)***Read/Write*

BAO	BAO	BAO	BAO	BAO	BAO	BAO	BAO
31-28	27-24	23-20	19-16	15-12	11-8	7-4	3-0

Default &gt;&gt;&gt;

X X X X X X X XXX0

This register has bit zero hardwired to zero. For detailed information on the operation of this register, refer to the PCI specification. This Base Address One register maps SCSI operating registers into memory space.



**Register 18h**  
Base Address Two (Memory)  
*Read/Write*

BAT	BAT	BAT	BAT	BAT	BAT	BAT	BAT
31-28	27-24	23-20	19-16	15-12	11-8	7-4	3-0
Default >>>							
X	X	X	X	X	X	X	XXX0

This register has bit zero hardwired to zero. The other bits are used to map the 4 KB SCRIPTS RAM into memory space. This register is enabled only if the internal SCRIPTS RAM is enabled. The internal SCRIPTS RAM is disabled by connecting a 4.7 KΩ resistor between MAD5 and ground, which is sensed immediately after a chip reset. SCRIPTS RAM is also disabled by setting the Enable Memory Space bit to zero in the SCSI PCI Configuration Command register, bit 1.

If MAD5 is left unconnected, an internal pull-up enables the SCRIPTS RAM and this Base Address register.

If enabled, as with all Base Address registers, initialize this Base Address register to a value that does not conflict with other memory resources. Otherwise, memory conflicts may occur.

For detailed information on the operation of this register, refer to the PCI specification.

**Register 2Ch**  
Subsystem Vendor ID  
*Read Only*

SVID	SVID	SVID	SVID
15-12	11-8	7-4	3-0
If EEPROM not enabled <<<Default>>> Mode A			
0	0	0	0
If EEPROM not enabled <<<Default>>> Mode D			
1	0	0	0
EEPROM value if EEPROM enabled <<<Default>>>			
X	X	X	X

This register uniquely identifies the vendor manufacturing the add-in board or subsystem where this PCI device resides. It provides a mechanism for an add-in card vendor to distinguish its cards from another vendor's cards, even if the cards have the same PCI controller installed on them (and therefore the same Vendor ID and Device ID). This register loads automatically at powerup from an external serial EEPROM if in operating mode A and the load from EEPROM is successful. The 16-bit value that should be stored in the external serial EEPROM for this register is the vendor's PCI Vendor ID and must be obtained from the PCI Special Interest Group (SIG). If in operating mode D, this register is loaded with a default value of 1000h. If an error occurs during a load from EEPROM or if the operating mode is B, this register defaults to a value of 0000h. See the *Serial EEPROM Interface* section in Chapter 2 for information about the values to load in this register.

**Register 2Eh**  
**Subsystem ID**  
*Read Only*

SID 15-12	SID 11-8	SID 7-4	SID 3-0
If EEPROM not enabled <<<Default>>> Mode A			
0	0	0	0
If EEPROM not enabled <<<Default>>> Mode D			
1	0	0	0
EEPROM value if EEPROM enabled <<<Default>>>			
X	X	X	X

This register uniquely identifies the add-in board or subsystem where this PCI device resides. It provides a mechanism for an add-in card vendor to distinguish its cards from one another even if the cards have the same PCI controller installed on them (and therefore the same Vendor ID and Device ID). This register loads automatically at powerup from an external serial EEPROM if in operating mode A and the load from EEPROM is successful. The 16-bit value that should be stored in the external serial EEPROM for this register is vendor-specific. If in operating mode D, this register is loaded with a default value of 1000h. If an error occurs during a load from EEPROM or if the operating mode is B, this register defaults to a value of 0000h. See the *Serial EEPROM Interface* section in Chapter 2 for information about the values to load in this register.

**Register 30h**  
**Expansion ROM Base Address**  
*Read/Write*

ERBA 31-28	ERBA 27-24	ERBA 23-20	ERBA 19-16	ERBA 15-12	ERBA 11-8	ERBA 7-4	ERBA 3-0
Default>>>							
0	0	0	0	0	0	0	0

This four-byte register handles the base address and size information for the expansion ROM. It functions exactly like the Base Address registers, except that the encoding of the bits is different. The upper 21 bits correspond to the upper 21 bits of the expansion ROM base address.

The expansion ROM Enable bit, bit 0, is the only bit defined in this register. This bit controls whether or not the device accepts accesses to its expansion ROM. When the bit is set, address decoding is enabled, and a device is used with or without an expansion ROM depending on the system configuration. To access the external memory interface, also set the Memory Space bit in the Command register.

The host system detects the size of the external memory by first writing the Expansion ROM Base Address register with all ones and then reading back the register. The SCSI functions of the SYM53C876 respond with zeroes in all don't care locations. The ones in the remaining bits represent the binary version of the external memory size. For example, to indicate an external memory size of 32 KB, this register, when written with ones and read back, returns ones in the upper 17 bits.

The ROM is accessed through the MAD bus which is common to both SCSI functions in this device.

**Register 34h**  
**Capabilities Pointer**  
*Read Only*

CP	CP	CP	CP	CP	CP	CP	CP
7	6	5	4	3	2	1	0
Default >>>							
0	1	0	0	0	0	0	0

This register provides an offset into the function's PCI Configuration Space for the location of the first item in the capabilities linked list. Only the SYM53C876E sets this register to 40h.

**Register 3Ch**  
**Interrupt Line**  
*Read/Write*

IL	IL	IL	IL	IL	IL	IL	IL
7	6	5	4	3	2	1	0
Default >>>							
0	0	0	0	0	0	0	0

This register can communicate interrupt line routing information. POST software writes the routing information into this register as it configures the system. The value in this register tells which input of the system interrupt controller(s) the device's interrupt pin is connected to. Values in this register are specified by system architecture.

**Register 3Dh**  
**Interrupt Pin**  
*Read Only*

IP	IP	IP	IP	IP	IP	IP	IP
7	6	5	4	3	2	1	0

SCSI Function A <<<Default >>>							
0	0	0	0	0	0	0	1
SCSI Function B if MAD(4) pulled low <<<Default >>>							
0	0	0	0	0	0	0	1
SCSI Function B if MAD(4) not pulled low <<<Default >>>							
0	0	0	0	0	0	1	0

This register is unique to each SCSI function. It tells which interrupt pin the device uses. Its value is set to 01h for the Function A INTA/ signal, and 02h for the Function B INTB/ signal at power-up. The Function B INTB/ value is set to 01h if MAD(4) is pulled low.

**Register 3Eh**  
**Min\_Gnt**  
*Read Only*

MG	MG	MG	MG	MG	MG	MG	MG
7	6	5	4	3	2	1	0

Default >>>							
0	0	0	1	0	0	0	1

This register specifies the desired settings for latency timer values. Min\_Gnt specifies how long a burst period the device needs. The value specified in these registers is in units of 0.25 microseconds. The SYM53C876 SCSI function sets this register to 11h.

**Register 3Fh**  
**Max\_Lat**  
*Read Only*

ML	ML	ML	ML	ML	ML	ML	ML
7	6	5	4	3	2	1	0
Default >>>							
0	1	0	0	0	0	0	0

This register indicates the desired settings for latency timer values. Max\_Lat specifies how often the device needs to gain access to the PCI bus. The value specified in these registers is in units of 0.25 microseconds. The SYM53C876 SCSI function sets this register to 40h.

**Register 40h**  
**Capability ID**  
*Read Only*

CID	CID	CID	CID	CID	CID	CID	CID
7	6	5	4	3	2	1	0
Default >>>							
0	0	0	0	0	0	0	1

This register indicates the type of the current data structure. This register applies to the SYM53C876E only, which sets this register to a value of 01h, indicating the Power Management Data Structure.

**Register 41h**  
**Next Item Pointer**  
*Read Only*

NP	NP	NP	NP	NP	NP	NP	NP
7	6	5	4	3	2	1	0
Default >>>							
0	0	0	0	0	0	0	0

This register describes the location of the next item in the function's capability list. This register applies only to the SYM53C876E, which sets this register to a value of 00h, indicating that power management is the last capability in the linked list of extended capabilities.

**Register 42h**  
**Power Management Capabilities**  
*Read Only*

PMES	D2S	D1S	RES	DSI	APS	PMEC	VER
15-11	10	9	8-6	5	4	3	2-0
Default >>>							
0	1	1	0	0	0	0	1

This register applies to the SYM53C876E only and indicates the power management capabilities.

**Bit 15-11PME Support (PMES)**

This field is always set to 00000b because the SYM53C876E does not provide a PME signal.

**Bit 10 D2 Support (D2S)**

The SYM53C876E sets this bit to indicate that it supports the D2 power management state.

**Bit 9 D1 Support (D1S)**

The SYM53C876E sets this bit to indicate that it supports the D1 power management state.

**Bits 8-6Reserved**

**Bit 5 Device Specific Initialization (DSI)**

This bit is set to 0 to indicate that the SYM53C876E requires no special initiation before the generic class device driver is able to use it.

**Bit 4 Auxiliary Power Source (APS)**

Because the SYM53C876E does not provide a PME signal, this bit always returns a 0, indicating that no auxiliary power source is required to support the PME signal in the D3cold power management state.

**Bit 3 PME Clock (PMEC)**

This field is always set to 00000b because the SYM53C876E does not provide a PME signal.

**Bits 2-0Version (VER)**

This field is set to 001b to indicate that the SYM53C876E complies with Revision 1.0 of the PCI Power Management Interface Specification.

**Register 44h**  
**Power Management Control/Status**  
*Read/Write*

PST	DSCL	DSLTL	PEN	RES	PWS
15	14-13	12-9	8	7-2	1-0
Default >>>					
0	0	0	0	0	0

This register applies to the SYM53C876E only and indicates the power management control and status descriptions.

**Bit 15 PME Status (PST)**

The SYM53C876E always returns a 0 for this bit, indicating that PME signal generation is not supported from D3cold.

**Bit 14-13 Data Scale (DSCL)**

The SYM53C876E does not support the Data register, therefore this field is always set to 00b.

**Bit 12-9 Data Select (DSLTL)**

The SYM53C876E does not support the Data register, therefore this field is always set to 0000b.

**Bits 8 PME Enable (PEN)**

The SYM53C876E always returns a 0 for this bit to indicate that PME assertion is disabled.

**Bit 7-2 Reserved**

**Bits 1-0 Power State (PWS)**

This two bit field determines the current power state for the function and is used to set the function to a new power state. The definition of the field values are:

- 00b - D0
- 01b - D1
- 10b - D2
- 11b - D3hot

See the section on Power Management in Chapter 2 of this document for descriptions of the power management states.

**Register 46h**  
**PMCSR BSE**  
*Read Only*

BSE	BSE	BSE	BSE	BSE	BSE	BSE	BSE
7	6	5	4	3	2	1	0
Default >>>							
0	0	0	0	0	0	0	0

This register applies only to the SYM53C876E and can support PCI bridge specific functionality if required. The default value always returns 00h.

---

## Register 47h

Data

*Read Only*

Data	Data	Data	Data	Data	Data	Data	Data
7	6	5	4	3	2	1	0

Default >>>

0 0 0 0 0 0 0 0

This register applies only to the SYM53C876E and provides an optional mechanism for the function to report state-dependent operating data. The SYM53C876E returns 00h as the default value.

---

## SCSI Registers

This section contains descriptions of all SYM53C876 SCSI registers. Table 4-2 summarizes the SYM53C876 operating register set. Table 4-3, the register map, lists registers by operating and configuration addresses. The terms “set” and “assert” refer to bits that are programmed to a binary one. Similarly, the terms “deassert,” “clear” and “reset” refer to bits that are programmed to a binary zero. Write any bits are marked as reserved to zero; mask all information read from them. Reserved bit functions may change at any time. Unless otherwise indicated, all bits in registers are active high, that is, the feature is enabled by setting the bit. The bottom row of every register diagram shows the default register values, which are enabled after the chip is powered on or reset.

**Note:** The only register that the host CPU can access while the SYM53C876 is executing SCRIPTS is the ISTAT register; attempts to access other registers interferes with the operation of the chip. However, all operating registers are accessible with SCRIPTS. All read data is synchronized and stable when presented to the PCI bus.



Table 4-2: SCSI Operating Register Addresses and Descriptions

Memory or I/O Address	Read/Write	Label	Description
00	R/W	SCNTL0	SCSI Control 0
01	R/W	SCNTL1	SCSI Control 1
02	R/W	SCNTL2	SCSI Control 2
03	R/W	SCNTL3	SCSI Control 3
04	R/W	SCID	SCSI Chip ID
05	R/W	SXFER	SCSI Transfer
06	R/W	SDID	SCSI Destination ID
07	R/W	GPREG	General Purpose Bits
08	R/W	SFBR	SCSI First Byte Received
09	R/W	SOCL	SCSI Output Control Latch
0A	R	SSID	SCSI Selector ID
0B	R/W	SBCL	SCSI Bus Control Lines
0C	R	DSTAT	DMA Status
0D	R	SSTAT0	SCSI Status 0
0E	R	SSTAT1	SCSI Status 1
0F	R	SSTAT2	SCSI Status 2
10-13	R/W	DSA	Data Structure Address
14	R/W	ISTAT	Interrupt Status
18	R/W	CTEST0	Reserved
19	R/W	CTEST1	Chip Test 1
1A	R	CTEST2	Chip Test 2
1B	R	CTEST3	Chip Test 3
1C-1F	R/W	TEMP	Temporary Register
20	R/W	DFIFO	DMA FIFO
21	R/W	CTEST4	Chip Test 4
22	R/W	CTEST5	Chip Test 5
23	R/W	CTEST6	Chip Test 6
24-26	R/W	DBC	DMA Byte Counter
27	R/W	DCMD	DMA Command
28-2B	R/W	DNAD	DMA Next Address for Data
2C-2F	R/W	DSP	DMA SCRIPTS Pointer
30-33	R/W	DSPTS	DMA SCRIPTS Pointer Save
34-37	R/W	SCRATCHA	General Purpose Scratch Pad A
38	R/W	DMODE	DMA Mode

**Table 4-2: SCSI Operating Register Addresses and Descriptions (Continued)**

Memory or I/O Address	Read/Write	Label	Description
39	R/W	DIEN	DMA Interrupt Enable
3A	R/W	SBR	Scratch Byte Register
3B	R/W	DCNTL	DMA Control
3C-3F	R	ADDER	Sum output of internal adder
40	R/W	SIEN0	SCSI Interrupt Enable 0
41	R/W	SIEN1	SCSI Interrupt Enable 1
42	R	SIST0	SCSI Interrupt Status 0
43	R	SIST1	SCSI Interrupt Status 1
44	R/W	SLPAR	SCSI Longitudinal Parity
45	R	SWIDE	SCSI Wide Residue Data
46	R/W	MACNTL	Memory Access Control
47	R/W	GPCNTL	General Purpose Control
48	R/W	STIME0	SCSI Timer 0
49	R/W	STIME1	SCSI Timer 1
4A	R/W	RESPID0	Response ID 0
4B	R/W	RESPID1	Response ID 1
4C	R	STEST0	SCSI Test 0
4D	R	STEST1	SCSI Test 1
4E	R/W	STEST2	SCSI Test 2
4F	R/W	STEST3	SCSI Test 3
50-51	R	SIDL	SCSI Input Data Latch
52-53			Reserved
54-55	R/W	SODL	SCSI Output Data Latch
56-57			Reserved
58-59	R	SBDL	SCSI Bus Data Lines
5A-5B			Reserved
5C-5F	R/W	SCRATCHB	General Purpose Scratch Pad B
60-7F	R/W	SCRATCHC-J	General Purpose Scratch Pad C-J

**Table 4-3: SYM53C876 SCSI Register Address Map**

				Mem I/O
SCNTL3	SCNTL2	SCNTL1	SCNTL0	00
GPREG	SDID	SXFER	SCID	04
SBCL	SSID	SOCL	SFBR	08
SSTAT2	SSTAT1	SSTAT0	DSTAT	0C
DSA				10
Reserved			ISTAT	14
CTEST3	CTEST2	CTEST1	CTEST0	18
TEMP				1C
CTEST6	CTEST5	CTEST4	DFIFO	20
DCMD	DBC			24
DNAD				28
DSP				2C
DSPS				30
SCRATCHA				34
DCNTL	SBR	DIEN	DMODE	38
ADDER				3C
SIST1	SIST0	SIEN1	SIEN0	40
GPCNTL	MACNTL	SWIDE	SLPAR	44
RESPID1	RESPID0	STIME1	STIME0	48
STEST3	STEST2	STEST1	STEST0	4C
Reserved		SIDL		50
Reserved		SODL		54
Reserved		SBDL		58
SCRATCHB				5C
SCRATCHC				60
SCRATCHD				64
SCRATCHE				68
SCRATCHF				6C
SCRATCHG				70
SCRATCHH				74
SCRATCHI				78
SCRATCHJ				7C

**Register 00h**  
**SCSI Control Zero (SCNTL0)**  
*Read/Write*

ARB1	ARB0	STAR T	WATN	EPC	RES	AAP	TRG
7	6	5	4	3	2	1	0

Default >>>

1 1 0 0 0 X 0 0

**Bit 7 ARB1 (Arbitration Mode bit 1)**

**Bit 6 ARB0 (Arbitration Mode bit 0)**

ARB1	ARB0	Arbitration Mode
0	0	Simple arbitration
0	1	Reserved
1	0	Reserved
1	1	Full arbitration, selection/reselection

**Simple Arbitration**

1. The SYM53C876 SCSI function waits for a bus free condition to occur.
2. It asserts SBSY/ and its SCSI ID (contained in the SCID register) onto the SCSI bus. If the SSEL/ signal is asserted by another SCSI device, the SYM53C876 SCSI function deasserts SBSY/, deasserts its ID and sets the Lost Arbitration bit (bit 3) in the SSTAT0 register.
3. After an arbitration delay, the CPU should read the SBDL register to check if a higher priority SCSI ID is present. If no higher priority ID bit is set, and the Lost Arbitration bit is not set, the SYM53C876 SCSI function wins arbitration.
4. Once the SYM53C876 SCSI function wins arbitration, assert SSEL/ via the SOCL for a bus clear plus a bus settle delay (1.2 μs) before a low level selection is performed.

**Full Arbitration, Selection/Reselection**

1. The SYM53C876 SCSI function waits for a bus free condition.
2. It asserts SBSY/ and its SCSI ID (the highest priority ID stored in the SCID register) onto the SCSI bus.
3. If the SSEL/ signal is asserted by another SCSI device or if the SYM53C876 SCSI function detects a higher priority ID, the SYM53C876 SCSI function deasserts BSY, deasserts its ID, and waits until the next bus free state to try arbitration again.
4. The SYM53C876 SCSI function repeats arbitration until it wins control of the SCSI bus. When it wins, the Won Arbitration bit is set in the SSTAT0 register, bit 2.
5. The SYM53C876 SCSI function performs selection by asserting the following onto the SCSI bus: SSEL/, the target's ID (stored in the SDID register), and the SYM53C876's ID (stored in the SCID register).
6. After a selection is complete, the Function Complete bit is set in the SIST0 register, bit 6.
7. If a selection time-out occurs, the Selection Time-Out bit is set in the SIST1 register, bit 2.

**Bit 5 START (Start Sequence)**

When this bit is set, the SYM53C876 starts the arbitration sequence indicated by the Arbitration Mode bits. The Start Sequence bit is accessed directly in low-level mode; during SCSI SCRIPTS operations, this bit is controlled by the SCRIPTS processor. Do not start an arbitration sequence if the connected (CON) bit in the SCNTL1 register, bit 4, indicates that the SYM53C876 is already connected to the SCSI bus. This bit is automatically cleared when the arbitration sequence is complete. If a sequence is aborted, check bit 4

in the SCNTL1 register to verify that the SYM53C876 is not connected to the SCSI bus.

**Bit 4 WATN (Select with SATN/ on a Start Sequence)**

When this bit is set and the SYM53C876 SCSI function is in initiator mode, the SATN/ signal is asserted during selection of a SCSI target device. The SATN/ signal informs the target that the SYM53C876 SCSI function has a message to send. If a selection time-out occurs while attempting to select a target device, SATN/ is deasserted at the same time SSEL/ is deasserted. When this bit is clear, the SATN/ signal is not asserted during selection. When executing SCSI SCRIPTS, this bit is controlled by the SCRIPTS processor, but manual setting is possible in low level mode.

**Bit 3 EPC (Enable Parity Checking)**

When this bit is set, the SCSI data bus is checked for odd parity when data is received from the SCSI bus in either initiator or target mode. If a parity error is detected, bit 0 of the SIST0 register is set and an interrupt may be generated.

If the SYM53C876 SCSI function is operating in initiator mode and a parity error is detected, assertion of SATN/ is optional, but the transfer continues until the target changes phase. When this bit is cleared, parity errors are not reported.

**Bit 2 Reserved**

**Bit 1 AAP (Assert SATN/ on Parity Error)**

When this bit is set, the SYM53C876 SCSI function automatically asserts the SATN/ signal upon detection of a parity error. SATN/ is only asserted in initiator mode. The SATN/ signal is asserted before deasserting SACK/ during the byte transfer with the parity error. Also set the Enable Parity Checking bit for the SYM53C876 SCSI function to assert SATN/ in this manner. A parity error is detected on data received from the SCSI bus.

If the Assert SATN/ on Parity Error bit is cleared or the Enable Parity Checking bit is cleared, SATN/ is not automatically asserted on the SCSI bus when a parity error is received.

**Bit 0 TRG (Target Mode)**

This bit determines the default operating mode of the SYM53C876 SCSI function. The user must manually set the target or initiator mode. This is done using the SCRIPTS language (SET TARGET or CLEAR TARGET). When this bit is set, the chip is a target device by default. When this bit is cleared, the SYM53C876 SCSI function is an initiator device by default.

**CAUTION:**

Writing this bit while not connected may cause the loss of a selection or reselection due to the changing of target or initiator modes.

**Register 01h**  
**SCSI Control One (SCNTL1)**  
*Read/Write*

EXC	ADB	DHP	CON	RST	AESP	IARB	SST
7	6	5	4	3	2	1	0
Default >>>							
0	0	0	0	0	0	0	0

**Bit 7 EXC (Extra Clock Cycle of Data Setup)**

When this bit is set, an extra clock period of data setup is added to each SCSI send data transfer. The extra data setup time can provide additional system design margin, though it affects the SCSI transfer rates. Clearing this bit disables the extra clock cycle of data setup time. Setting this bit only affects SCSI send operations.

**Bit 6 ADB (Assert SCSI Data Bus)**

When this bit is set, the SYM53C876 SCSI function drives the contents of the SCSI Output Data Latch Register (SODL) onto the SCSI data bus. When the SYM53C876 SCSI function is an initiator, the SCSI I/O signal must be inactive to assert the SODL contents onto the SCSI bus. When the SYM53C876 SCSI function is a target, the SCSI I/O signal must be active to assert the SODL contents onto the SCSI bus. The contents of the SODL register can be asserted at any time, even before the SYM53C876 SCSI function is connected to the SCSI bus. Clear this bit when executing SCSI SCRIPTS. It is normally used only for diagnostics testing or operation in low level mode.

**Bit 5 DHP (Disable Halt on Parity Error or ATN) (Target Only)**

The DHP bit is only defined for target mode. When this bit is cleared, the SYM53C876 SCSI function halts the SCSI data transfer when a parity error is detected or when the SATN/ signal is asserted. If SATN/ or a parity error is received in the middle of a data trans-

fer, the SYM53C876 SCSI function may transfer up to three additional bytes before halting to synchronize between internal core cells. During synchronous operation, the SYM53C876 SCSI function transfers data until there are no outstanding synchronous offsets. If the SYM53C876 SCSI function is receiving data, any data residing in the DMA FIFO is sent to memory before halting.

When this bit is set, the SYM53C876 SCSI function does not halt the SCSI transfer when SATN/ or a parity error is received.

**Bit 4 CON (Connected)**

This bit is automatically set any time the SYM53C876 SCSI function is connected to the SCSI bus as an initiator or as a target. It is set after the SYM53C876 SCSI function successfully completes arbitration or when it has responded to a bus initiated selection or reselection. This bit is also set after the chip wins simple arbitration when operating in low level mode. When this bit is clear, the SYM53C876 SCSI function is not connected to the SCSI bus.

The CPU can force a connected or disconnected condition by setting or clearing this bit. This feature is used primarily during loopback mode.

**Bit 3 RST (Assert SCSI RST/ Signal)**

Setting this bit asserts the SRST/ signal. The SRST/ output remains asserted until this bit is cleared. The 25  $\mu$ s minimum assertion time defined in the SCSI specification must be timed out by the controlling microprocessor or a SCRIPTS loop.

**Bit 2 AESP (Assert Even SCSI Parity (force bad parity))**

When this bit is set, the SYM53C876 SCSI function asserts even parity. It forces a SCSI parity error on each byte sent to the SCSI bus from the chip. If parity checking is enabled, then the SYM53C876 SCSI function checks data received for odd parity. This bit is used

for diagnostic testing and is cleared for normal operation. It is useful to generate parity errors to test error handling functions.

#### Bit 1 IARB (Immediate Arbitration)

Setting this bit causes the SCSI core to immediately begin arbitration once a Bus Free phase is detected following an expected SCSI disconnect. This bit is useful for multi-threaded applications. The ARB1-0 bits in SCNTL0 is set for full arbitration and selection before setting this bit.

Arbitration is re-tried until won. At that point, the SYM53C876 SCSI function holds BSY and SEL asserted, and waits for a select or reselect sequence. The Immediate Arbitration bit is reset automatically when the selection or reselection sequence is completed, or times out. During the time between the assertion of the IARB bit and the completion of a Perform Select/Reselect instruction, DMA interrupts are disabled. Therefore, interrupt instructions placed between the assertion of the IARB bit and the Perform Select/Reselect instruction are not executed.

An unexpected disconnect condition clears IARB without attempting arbitration. See the SCSI Disconnect Unexpected bit (SCNTL2, bit 7) for more information on expected versus unexpected disconnects.

It is possible to abort an immediate arbitration sequence. First, set the Abort bit in the ISTAT register. Then one of two things eventually happens:

1. The Won Arbitration bit (SSTAT0 bit 2) is set. In this case, the Immediate Arbitration bit needs to be reset. This completes the abort sequence and disconnects the chip from the SCSI bus. If it is not acceptable to go to Bus Free phase immediately following the arbitration phase, it is possible to perform a low level selection instead.
2. The abort completes because the SYM53C876 SCSI function loses arbitration.

This is detected by the clearing of the Immediate Arbitration bit. Do not use the Lost Arbitration bit (SSTAT0 bit 3) to detect this condition. In this case take no further action.

#### Bit 0 SST (Start SCSI Transfer)

This bit is automatically set during SCRIPTS execution. It causes the SCSI core to begin a SCSI transfer, including SREQ/SACK handshaking. The determination of whether the transfer is a send or receive is made according to the value written to the I/O bit in SOCL. This bit is self-resetting. Do not set it for low level operation.

#### CAUTION:

Writing to this register while not connected may cause the loss of a selection/reselection by resetting the Connected bit.

**Register 02h**  
**SCSI Control Two (SCNTL2)**  
*Read/Write*

SDU	CHM	SLPM D	SLPH- BEN	WSS	VUE0	VUE1	WSR
7	6	5	4	3	2	1	0
Default >>>							
0	0	0	0	0	0	X	0

**Bit 7 SDU (SCSI Disconnect Unexpected)**

This bit is valid in initiator mode only. When this bit is set, the SCSI core is not expecting the SCSI bus to enter the Bus Free phase. If it does, an unexpected disconnect error is generated (see the Unexpected Disconnect bit in the SIST0 register, bit 2). During normal SCRIPTS mode operation, this bit is set automatically whenever the SCSI core is reselected, or successfully selects another SCSI device. The SDU bit should be reset with a register write (MOVE 0X00 TO SCNTL2) before the SCSI core expects a disconnect to occur, normally prior to sending an Abort, Abort Tag, Bus Device Reset, Clear Queue or Release Recovery message, or before deasserting SACK/ after receiving a Disconnect command or Command Complete message.

**Bit 6 CHM (Chained Mode)**

This bit determines whether or not the SCSI core is programmed for chained SCSI mode. This bit is automatically set by the Chained Block Move (CHMOV) SCRIPTS instruction and is automatically cleared by the Block Move SCRIPTS instruction (MOVE).

Chained mode primarily transfers consecutive wide data blocks. Using chained mode facilitates partial receive transfers and allows correct partial send behavior. When this bit is set and a data transfer ends on an odd byte boundary, the SYM53C876 SCSI function stores the last byte in the SCSI Wide Residue Data Register during a receive operation, or in the SCSI Output Data Latch register during a send operation. This byte is combined with

the first byte from the subsequent transfer so that a wide transfer are completed.

For more information, see the “Chained Mode” section in Chapter 2, “Functional Description.”

**Bit 5 SLPMD (SLPAR Mode Bit)**

If this bit is clear, the SLPAR register functions as a byte-wide longitudinal parity register. If this bit is set, the SLPAR functions as a word-wide longitudinal parity function. The high or low byte of the SLPAR word is accessible through the SLPAR register. The SLPHEN bit controls the byte that is accessible.

**Bit 4 SLPHBEN (SLPAR High Byte Enable)**

If this bit is clear, the low byte of the SLPAR word is present in the SLPAR register. If this bit is set, the high byte of the SLPAR word is present in the SLPAR register.

**Bit 3 WSS (Wide SCSI Send)**

When read, this bit returns the value of the Wide SCSI Send (WSS) flag. Asserting this bit clears the WSS flag. This clearing function is self-resetting.

When the WSS flag is high following a wide SCSI send operation, the SCSI core is holding a byte of “chain” data in the SODL register. This data becomes the first low-order byte sent when married with a high-order byte during a subsequent data send transfer.

Performing a SCSI receive operation clears this bit. Also, performing any non-wide transfer clears this bit.

**Bit 2 VUE0 (Vendor Unique Enhancement bit 0)**

This bit is a read only value indicating whether the group code field in the SCSI instruction is standard or vendor unique. If reset, the bit indicates standard group codes; if set, the bit indicates vendor unique group



codes. The value in this bit is reloaded at the beginning of all asynchronous target receives.

**Bit 1 VUE1 (Vendor Unique Enhancement bit 1)**

This bit disables the automatic byte count reload during Block Move instructions in the command phase. If this bit is reset, the device reloads the Block Move byte count if the first byte received is one of the standard group codes. If this bit is set, the device does not reload the Block Move byte count, regardless of the group code.

**Bit 0 WSR (Wide SCSI Receive)**

When read, this bit returns the value of the Wide SCSI Receive (WSR) flag. Setting this bit clears the WSR flag. This clearing function is self-resetting.

The WSR flag indicates that the SCSI core received data from the SCSI bus, detected a possible partial transfer at the end of a chained or non-chained block move command, and temporarily stored the high-order byte in the SWIDE register rather than passing the byte out the DMA channel. The hardware uses the WSR status flag to determine what behavior must occur at the start of the next data receive transfer. When the flag is set, the stored data in SWIDE may be “residue” data, valid data for a subsequent data transfer, or overrun data. The byte is read as normal data by starting a data receive transfer.

Performing a SCSI send operation clears this bit. Also, performing any non-wide transfer clears this bit.

**Register 03h**  
**SCSI Control Three (SCNTL3)**  
*Read/Write*

USE	SCF2	SCF1	SCF0	EWS	CCF2	CCF1	CCF0
7	6	5	4	3	2	1	0

Default >>>

0 0 0 0 0 0 0 0

**Bit 7 USE (Ultra SCSI Enable)**

Setting this bit enables Ultra SCSI synchronous transfers. The default value of this bit is 0. Set this bit only when the transfer rate exceeds 10 Mega-transfers/sec.

When this bit is set, the signal filtering period for SREQ/ and SACK/ automatically changes to 15 ns, regardless of the value of the Extend REQ/ACK Filtering bit in the STEST2 register.

**Bits 6-4 SCF2-0 (Synchronous Clock Conversion Factor)**

These bits select a factor by which the frequency of SCLK is divided before being presented to the synchronous SCSI control logic. Write these to the same value as the Clock Conversion Factor bits below unless fast SCSI operation is desired. See the SCSI Transfer (SXFER) register description for examples of how the SCF bits are used to calculate synchronous transfer periods. See the table under the description of bits 7-5 of the SXFER register for the valid combinations.

Note: For additional information on how the synchronous transfer rate is determined, refer to Chapter 2, *Functional Description*.

**Bit 3 EWS (Enable Wide SCSI)**

When this bit is clear, all information transfer phases are assumed to be eight bits, transmitted on SD7-0/, SDP0/. When this bit is asserted, data transfers are done 16 bits at a time, with the least significant byte on SD7-0/ , SDP/ and the most significant byte on SD15-8/, SDP1/. Command, Status, and Message phases are not affected by this bit.

**Bits 2-0 CCF2-0 (Clock Conversion Factor)**

These bits select a factor by which the frequency of SCLK is divided before being presented to the SCSI core. The synchronous portion of the SCSI core can be run at a different clock rate for fast SCSI, using the Synchronous Clock Conversion Factor bits. The bit encoding is displayed in the table below. All other combinations are reserved.

SCF2 CCF2	SCF1 CCF1	SCF0 CCF0	Factor Frequency	SCSI Clock (MHz)
0	0	0	SCLK/3	50.01-75.0
0	0	1	SCLK/1	16.67-25.0
0	1	0	SCLK/1.5	25.01-37.5
0	1	1	SCLK/2	37.51-50.0
1	0	0	SCLK/3	50.01-75.0
1	0	1	SCLK/4	75.01-80.00
1	1	0	SCLK/6	120
1	1	1	SCLK/8	160

Note: It is important that these bits are set to the proper values to guarantee that the SYM53C876 meets the SCSI timings as defined by the ANSI specification.

**Register 04h  
SCSI Chip ID (SCID)  
Read/Write**

RES 7	RRE 6	SRE 5	RES 4	ENC3 3	ENC2 2	ENC1 1	ENC0 0
----------	----------	----------	----------	-----------	-----------	-----------	-----------

Default >>>  
X 0 0 X 0 0 0 0

**Bit 7 Reserved**

**Bit 6 RRE (Enable Response to Reselection)**

When this bit is set, the SYM53C876 SCSI function is enabled to respond to bus-initiated reselection at the chip ID in the RESPID0 and RESPID1 registers. Note that the chip does not automatically reconfigure itself to initiator mode as a result of being reselected.

**Bit 5 SRE (Enable Response to Selection)**

When this bit is set, the SYM53C876 SCSI function is able to respond to bus-initiated selection at the chip ID in the RESPID0 and RESPID1 registers. Note that the chip does not automatically reconfigure itself to target mode as a result of being selected.

**Bit 4 Reserved**

**Bits 3-0 Encoded Chip SCSI ID, bits 3-0**

These bits store the SYM53C876 SCSI function encoded SCSI ID. This is the ID which the chip asserts when arbitrating for the SCSI bus. The IDs that the SYM53C876 SCSI function responds to when selected or reselected are configured in the RESPID0 and RESPID1 registers. The priority of the 16 possible IDs, in descending order is:

Highest								Lowest							
7	6	5	4	3	2	1	0	15	14	13	12	11	10	9	8

**Register 05h**  
**SCSI Transfer (SXFER)**  
*Read/Write*

TP2	TP1	TP0	M04	M03	M02	M01	M00
7	6	5	4	3	2	1	0

Default >>>

0 0 0 X 0 0 0 0

**Note:** When using Table Indirect I/O commands, bits 7-0 of this register are loaded from the I/O data structure.

**Note:** For additional information on how the synchronous transfer rate is determined, refer to Chapter 2, *Functional Description*.

**Bits 7-5 TP2-0 (SCSI Synchronous Transfer Period)**

These bits determine the SCSI synchronous transfer period used by the SYM53C876 SCSI function when sending synchronous SCSI data in either initiator or target mode. These bits control the programmable dividers in the chip.

**Note:** For Wide Ultra SCSI transfers, the ideal transfer period is 4, and 5 is acceptable. Setting the transfer period to a value greater than 5 is not recommended.

TP2	TP1	TP0	XFERP
0	0	0	4
0	0	1	5
0	1	0	6
0	1	1	7
1	0	0	8
1	0	1	9
1	1	0	10
1	1	1	11

The synchronous transfer period the SYM53C876 should use when transferring SCSI data is determined as in this exam-

ple. The SYM53C876 is connected to a hard disk that can transfer data at 10 MB/s synchronously. The SYM53C876 SCSI function's SCLK is running at 40 MHz. The synchronous transfer period (SXFERP) is found as follows:

$$\text{SXFERP} = \text{Period} / \text{SSCP} + \text{ExtCC}$$

$$\text{Period} = 1 \div \text{Frequency} = 1 \div 10 \text{ MB/s} = 100 \text{ ns}$$

$$\text{SSCP} = 1 \div \text{SSCF} = 1 \div 40 \text{ MHz} = 25 \text{ ns}$$

(This SCSI synchronous core clock is determined in SCNTL3 bits 6-4

ExtCC = 1 if SCNTL1 bit 7 is asserted and the 53C876 is sending data.

ExtCC = 0 if the 53C876 is receiving data)

$$\text{SXFERP} = 100 \div 25 = 4$$

**Key:**

SXFERP = Synchronous transfer period

SSCP = SCSI Synchronous core period

SSCF = SCSI Synchronous core frequency

ExtCC = Extra clock cycle of data setup

**Table 4-4: Examples of Synchronous Transfer Periods for SCSI-1 Transfer Rates**

CLK (MHz)	SCSI CLK ÷ SCNTL3 bits 6-4	XFERP	Synch. Transfer Period (ns)	Synch. Transfer Rate (MB/s)
40	÷4	4	200	5
80	÷2	4	200	5

**Table 4-5: Example Transfer periods for Fast SCSI and Wide Ultra SCSI transfer rates**

CLK (MHz)	SCSI CLK ÷ SCNTL3 bits 6-4	XFERP	Synch. Transfer Period (ns)	Synch. Transfer Rate (MB/s)
80	÷1	4	50	20
80	÷2	4	100	10
40	÷1	4	100	10

**Bits 4-0 MO4-MO0 (Max SCSI Synchronous Offset)**

These bits describe the maximum SCSI synchronous offset used by the SYM53C876 SCSI function when transferring synchronous SCSI data in either initiator or target mode. The following table describes the possible combinations and their relationship to the synchronous data offset used by the SYM53C876 SCSI function. These bits determine the SYM53C876 SCSI function's method of transfer for Data In and Data Out phases only; all other information transfers occur asynchronously.

MO4	MO3	MO2	MO1	MO0	Synchronous Offset
0	0	0	0	0	0-Asynchronous
0	0	0	0	1	1
0	0	0	1	0	2
0	0	0	1	1	3
0	0	1	0	0	4
0	0	1	0	1	5
0	0	1	1	0	6
0	0	1	1	1	7
0	1	0	0	0	8
0	1	0	0	1	9
0	1	0	1	0	10
0	1	0	1	1	11
0	1	1	0	0	12
0	1	1	0	1	13
0	1	1	1	0	14
0	1	1	1	1	15
1	0	0	0	0	16
1	X	X	X	1	Reserved
1	X	X	1	X	Reserved
1	X	1	X	X	Reserved
1	1	X	X	X	Reserved

**Register 06h**  
**SCSI Destination ID (SDID)**  
*Read/Write*

RES	RES	RES	RES	ENC3	ENC2	ENC1	ENC0
7	6	5	4	3	2	1	0
Default >>>							
X	X	X	X	0	0	0	0

**Bits 7-4 Reserved**

**Bits 3-0 Encoded Destination SCSI ID**

Writing these bits sets the SCSI ID of the intended initiator or target during SCSI reselection or selection phases, respectively. When executing SCRIPTS, the SCRIPTS processor writes the destination SCSI ID to this register. The SCSI ID is defined by the user in a SCRIPTS Select or Reselect instruction. The value written is the binary-encoded ID. The priority of the 16 possible IDs, in descending order, is:

Highest								Lowest							
7	6	5	4	3	2	1	0	15	14	13	12	11	10	9	8

**Register 07h**  
**General Purpose (GPREG)**  
*Read/Write*

RES	RES	RES	GPIO4	GPIO3	GPIO2	GPIO1	GPIO0
7	6	5	4	3	2	1	0

Default >>>

X X X 0 X X X X

The general purpose register drives and senses values on the general purpose I/O pins. If both SCSI function GPREG registers define a single GPIO pin as an output, the results are indeterminate.

**Bits 7-5, 3 Reserved**

**Bits 4, 2-0 GPIO4-GPIO0 (General Purpose)**

These bits are programmed through the GPCNTL register as inputs, outputs, or to perform special functions. As an output, these pins enable or disable external terminators. It is also possible to program these signals as live inputs and sense them through a SCRIPTS Register to Register Move Instruction. GPIO(2-0) default as inputs and GPIO4 defaults as an output pin. When configured as inputs, an internal pull-up is enabled.

It is possible to use GPIO4 to enable or disable  $V_{PP}$ , the 12-volt power supply to the external flash memory. This bit powers up with the power to the external memory disabled.

The Symbios Logic PCI to SCSI host adapters use the GPIO4 pin in the process of flashing a new SDMS ROM.

Symbios Logic SDMS software uses the GPIO0 pin to toggle SCSI device LEDs, turning on the LED whenever the SYM53C876 SCSI function is on the SCSI bus. SDMS drives this pin low to turn on the LED, or drives it high to turn off the LED.

Symbios Logic software also uses the GPIO1-0 signals to access serial EEPROM. GPIO1 is used as a clock, with the GPIO0 pin serving as data.

**Register 08h**  
**SCSI First Byte Received (SFBR)**  
*Read/Write*

1B7	1B6	1B5	1B4	1B3	1B2	1B1	1B0
7	6	5	4	3	2	1	0
Default >>>							
0	0	0	0	0	0	0	0

This register contains the first byte received in any asynchronous information transfer phase. For example, when a SYM53C876 SCSI function is operating in initiator mode, this register contains the first byte received in the Message-In, Status, and Data-In phases.

When a Block Move instruction is executed for a particular phase, the first byte received is stored in this register— even if the present phase is the same as the last phase. The first byte received value for a particular input phase is not valid until after a MOVE instruction is executed.

This register is also the accumulator for register read-modify-writes with the SFBR as the destination. This allows bit testing after an operation.

The SFBR is not writable via the CPU, and therefore not by a Memory Move. However, it can be loaded via SCRIPTS Read/Write operations. To load the SFBR with a byte stored in system memory, the byte must first be moved to an intermediate SYM53C876 SCSI function register (such as the SCRATCH register), and then to the SFBR.

This register also contains the state of the lower eight bits of the SCSI data bus during the Selection phase if the COM bit in the DCNTL register is clear.

If the COM bit is cleared, do not access this register via SCRIPTS operation, as non-determinate operations may occur. (This includes SCRIPTS Read/Write operations and conditional transfer control instructions that initialize the SFBR register.)

**Register 09h**  
**SCSI Output Control Latch (SOCL)**  
*Read/Write*

REQ	ACK	BSY	SEL	ATN	MSG	C/D	I/O
7	6	5	4	3	2	1	0
Default >>>							
0	0	0	0	0	0	0	0

**Bit 7 REQ(Assert SCSI REQ/ Signal)**

**Bit 6 ACK(Assert SCSI ACK/ Signal)**

**Bit 5 BSY(Assert SCSI BSY/ Signal)**

**Bit 4 SEL(Assert SCSI SEL/ Signal)**

**Bit 3 ATN(Assert SCSI ATN/ Signal)**

**Bit 2 MSG(Assert SCSI MSG/ Signal)**

**Bit 1 C/D(Assert SCSI C\_D/ Signal)**

**Bit 0 I/O(Assert SCSI I\_O/ Signal)**

This register is used primarily for diagnostic testing or programmed I/O operation. It is controlled by the SCRIPTS processor when executing SCSI SCRIPTS. SOCL is used only when transferring data via programmed I/O. Some bits are set (1) or reset (0) when executing SCSI SCRIPTS. Do not write to the register once the SYM53C876 SCSI function starts executing normal SCSI SCRIPTS.

**Register 0Ah**  
SCSI Selector ID (SSID)  
*Read Only*

VAL	RES	RES	RES	ENID3	ENID2	ENID1	ENID0
7	6	5	4	3	2	1	0

Default >>>

0 X X X 0 0 0 0

**Bit 7 VAL (SCSI Valid)**

If VAL is asserted, then the two SCSI IDs are detected on the bus during a bus-initiated selection or reselection, and the encoded destination SCSI ID bits below are valid. If VAL is deasserted, only one ID is present and the contents of the encoded destination ID are meaningless.

**Bits 6-4 Reserved**

**Bits 3-0 Encoded Destination SCSI ID**

Reading the SSID register immediately after the SYM53C876 SCSI function is selected or reselected returns the binary-encoded SCSI ID of the device that performed the operation. These bits are invalid for targets that are selected under the single initiator option of the SCSI-1 specification. This condition is detected by examining the VAL bit above.

**Register 0Bh**  
SCSI Bus Control Lines (SBCL)  
*Read Only*

REQ	ACK	BSY	SEL	ATN	MSG	C/D	I/O
7	6	5	4	3	2	1	0

Default >>>

X X X X X X X X

**Bit 7 REQ (SREQ/ Status)**

**Bit 6 ACK (SACK/ Status)**

**Bit 5 BSY (SBSY/ Status)**

**Bit 4 SEL (SSEL/ Status)**

**Bit 3 ATN (SATN/ Status)**

**Bit 2 MSG (SMSG/ Status)**

**Bit 1 C/D (SC\_D/ Status)**

**Bit 0 I/O (SI\_O/ Status)**

This register returns the SCSI control line status. A bit is set when the corresponding SCSI control line is asserted. These bits are not latched; they are a true representation of what is on the SCSI bus at the time the register is read. The resulting read data is synchronized before being presented to the PCI bus to prevent parity errors from being passed to the system. This register is used for diagnostics testing or operation in low level mode.

**Register 0Ch**  
**DMA Status (DSTAT)**  
*Read Only*

DFE	MDPE	BF	ABRT	SSI	SIR	RES	IID
7	6	5	4	3	2	1	0
Default >>>							
1	0	0	0	0	0	X	0

Reading this register clears any bits that are set at the time the register is read, but does not necessarily clear the register in case additional interrupts are pending (the SYM53C876 SCSI functions stack interrupts). The DIP bit in the ISTAT register is also cleared. It is possible to mask DMA interrupt conditions individually through the DIEN register.

When performing consecutive 8-bit reads of the DSTAT, SIST0 and SIST1 registers (in any order), insert a delay equivalent to 12 CLK periods between the reads to ensure that the interrupts clear properly. See Chapter 2, *Functional Description*, for more information on interrupts.

**Bit 7 DFE (DMA FIFO Empty)**

This status bit is set when the DMA FIFO is empty. It is possible to use it to determine if any data resides in the FIFO when an error occurs and an interrupt is generated. This bit is a pure status bit and does not cause an interrupt.

**Bit 6 MDPE (Master Data Parity Error)**

This bit is set when the SYM53C876 SCSI function as a master detects a data parity error, or a target device signals a parity error during a data phase. This bit is completely disabled by the Master Parity Error Enable bit (bit 3 of CTEST4).

**Bit 5 BF (Bus Fault)**

This bit is set when a PCI bus fault condition is detected. A PCI bus fault can only occur when the SYM53C876 SCSI function is bus

master, and is defined as a cycle that ends with a Bad Address or Target Abort Condition.

**Bit 4 ABRT (Aborted)**

This bit is set when an abort condition occurs. An abort condition occurs when a software abort command is issued by setting bit 7 of the ISTAT register.

**Bit 3 SSI (Single Step Interrupt)**

If the Single-Step Mode bit in the DCNTL register is set, this bit is set and an interrupt generated after successful execution of each SCRIPTS instruction.

**Bit 2 SIR (SCRIPTS Interrupt Instruction Received)**

This status bit is set whenever an Interrupt instruction is evaluated as true.

**Bit 1 Reserved**

**Bit 0 IID (Illegal Instruction Detected)**

This status bit is set any time an illegal or reserved instruction op code is detected, whether the SYM53C876 SCSI function is operating in single-step mode or automatically executing SCSI SCRIPTS. Any of the following conditions during instruction execution also sets this bit:

1. The SYM53C876 SCSI function is executing a Wait Disconnect instruction and the SCSI REQ line is asserted without a disconnect occurring.
2. A Block Move instruction is executed with 000000h loaded into the DBC register, indicating there are zero bytes to move.
3. During a Transfer Control instruction, the Compare Data (bit 18) and Compare Phase (bit 17) bits are set in the DBC register while the SYM53C876 SCSI function is in target mode.
4. During a Transfer Control instruction, the Carry Test bit (bit 21) is set and either the



Compare Data (bit 18) or Compare Phase (bit 17) bit is set.

5. A Transfer Control instruction is executed with the reserved bit 22 set.
6. A Transfer Control instruction is executed with the Wait for Valid phase bit (bit 16) set while the chip is in target mode.
7. A Load/Store instruction is issued with the memory address mapped to the operating registers of the chip, not including ROM or RAM.
8. A Load/Store instruction is issued when the register address is not aligned with the memory address
9. A Load/Store instruction is issued with bit 5 in the DCMD register clear or bits 3 or 2 set.
10. A Load/Store instruction when the count value in the DBC register is not set at 1 to 4.
11. A Load/Store instruction attempts to cross a dword boundary.
12. A Memory Move instruction is executed with one of the reserved bits in the DCMD register set.
13. A Memory Move instruction is executed with the source and destination addresses not aligned.

**Register 0Dh**  
**SCSI Status Zero (SSTAT0)**  
*Read Only*

ILF	ORF	OLF	AIP	LOA	WOA	RST/	SDP0/
7	6	5	4	3	2	1	0
Default >>>							
0	0	0	0	0	0	0	0

**Bit 7 ILF (SIDL Least Significant Byte Full)**

This bit is set when the least significant byte in the SCSI Input Data Latch register (SIDL) contains data. Data is transferred from the SCSI bus to the SCSI Input Data Latch register before being sent to the DMA FIFO and then to the host bus. The SIDL register contains SCSI data received asynchronously. Synchronous data received does not flow through this register.

**Bit 6 ORF (SODR Least Significant Byte Full)**

This bit is set when the least significant byte in the SCSI Output Data Register (SODR, a hidden buffer register which is not accessible) contains data. The SCSI logic uses the SODR as a second storage register when sending data synchronously. It is not readable or writable by the user. It is possible to use this bit to determine how many bytes reside in the chip when an error occurs.

**Bit 5 OLF (SODL Least Significant Byte Full)**

This bit is set when the least significant byte in the SCSI Output Data Latch (SODL) contains data. The SODL register is the interface between the DMA logic and the SCSI bus. In synchronous mode, data is transferred from the host bus to the SODL register, and then to the SCSI Output Data Register (SODR, a hidden buffer register which is not accessible) before being sent to the SCSI bus. In asynchronous mode, data is transferred from the host bus to the SODL register, and then to the

SCSI bus. The SODR buffer register is not used for asynchronous transfers. It is possible to use this bit to determine how many bytes reside in the chip when an error occurs.

**Bit 4 AIP (Arbitration in Progress)**

Arbitration in Progress (AIP = 1) indicates that the SYM53C876 SCSI function has detected a Bus Free condition, asserted BSY, and asserted its SCSI ID onto the SCSI bus.

**Bit 3 LOA (Lost Arbitration)**

When set, LOA indicates that the SYM53C876 SCSI function has detected a bus free condition, arbitrated for the SCSI bus, and lost arbitration due to another SCSI device asserting the SEL/ signal.

**Bit 2 WOA (Won Arbitration)**

When set, WOA indicates that the SYM53C876 SCSI function has detected a Bus Free condition, arbitrated for the SCSI bus and won arbitration. The arbitration mode selected in the SCNTL0 register must be full arbitration and selection to set this bit.

**Bit 1 RST/ (SCSI RST/ Signal)**

This bit reports the current status of the SCSI RST/ signal, and the RST signal (bit 3) in the SCNTL1 register. This bit is not latched and may change as it is read.

**Bit 0 SDP0/ (SCSI SDP0/ Parity Signal)**

This bit represents the active high current status of the SCSI SDP0/ parity signal. This signal is not latched and may change as it is read.

**Register 0Eh**  
**SCSI Status One (SSTAT1)**  
*Read Only*

FF3	FF2	FF1	FF0	SDPOL	MSG	C/D	I/O
7	6	5	4	3	2	1	0

Default >>>

0	0	0	0	X	X	X	X
---	---	---	---	---	---	---	---

**Bits 7-4 FF3-FF0 (FIFO Flags)**

These four bits, along with SSTAT2 bit 4, define the number of bytes or words that currently reside in the 53C885's SCSI synchronous data FIFO. These bits are not latched and they will change as data moves through the FIFO. Because the FIFO can only hold either sixteen bytes or sixteen words, values over sixteen cannot occur.

FF4 (SSTAT2 bit 4)	FF3	FF2	FF1	FF0	Bytes or Words in the SCSI FIFO
0	0	0	0	0	0
0	0	0	0	1	1
0	0	0	1	0	2
0	0	0	1	1	3
0	0	1	0	0	4
0	0	1	0	1	5
0	0	1	1	0	6
0	0	1	1	1	7
0	1	0	0	0	8
0	1	0	0	1	9
0	1	0	1	0	10
0	1	0	1	1	11
0	1	1	0	0	12
0	1	1	0	1	13
0	1	1	1	0	14
0	1	1	1	1	15
1	0	0	0	0	16

**Bit 3 SDP0L (Latched SCSI Parity)**

This bit reflects the SCSI parity signal (SDP0/), corresponding to the data latched in the SCSI Input Data Latch register (SIDL). It changes when a new byte is latched into the least significant byte of the SIDL register.

This bit is active high, in other words, it is set when the parity signal is active.

**Bit 2 MSG (SCSI MSG/ Signal)**

**Bit 1 C/D (SCSI C\_D/ Signal)**

**Bit 0 I/O (SCSI I\_O/ Signal)**

These SCSI phase status bits are latched on the asserting edge of SREQ/ when operating in either initiator or target mode. These bits are set when the corresponding signal is active. They are useful when operating in low level mode.

**Register 0Fh**  
**SCSI Status Two (SSTAT2)**  
*Read Only*

ILF1	ORF1	OLF1	FF4	SPL1	RES	LDSC	SDP1
7	6	5	4	3	2	1	0

Default >>>

0 0 0 0 X X 1 X

**Bit 7 ILF1 (SIDL Most Significant Byte Full)**

This bit is set when the most significant byte in the SCSI Input Data Latch register (SIDL) contains data. Data is transferred from the SCSI bus to the SCSI Input Data Latch register before being sent to the DMA FIFO and then to the host bus. The SIDL register contains SCSI data received asynchronously. Synchronous data received does not flow through this register.

**Bit 6 ORF1 (SODR Most Significant Byte Full)**

This bit is set when the most significant byte in the SCSI Output Data Register (SODR, a hidden buffer register which is not accessible) contains data. The SCSI logic uses the SODR register as a second storage register when sending data synchronously. It is not accessible to the user. This bit determines how many bytes reside in the chip when an error occurs.

**Bit 5 OLF1 (SODL Most Significant Byte Full)**

This bit is set when the most significant byte in the SCSI Output Data Latch (SODL) contains data. The SODL register is the interface between the DMA logic and the SCSI bus. In synchronous mode, data is transferred from the host bus to the SODL register, and then to the SCSI Output Data Register (SODR, a hidden buffer register which is not accessible) before being sent to the SCSI bus. In asynchronous mode, data is transferred from the host bus to the SODL register, and then to the SCSI bus. The SODR buffer register is not

used for asynchronous transfers. It is possible to use this bit to determine how many bytes reside in the chip when an error occurs.

**Bit 4 FF4 (FIFO Flags bit 4)**

This is the most significant bit in the SCSI FIFO Flags field, with the rest of the bits in SSTAT1. For a complete description of this field, see the definition for SSTAT1 bits 7-4.

**Bit 3 SPL1(Latched SCSI parity for SD15-8)**

This active high bit reflects the SCSI odd parity signal corresponding to the data latched into the most significant byte in the SIDL register.

**Bit 2 DIFF (DIFFSENSE Sense)**

If this bit is reset, the correct cable type is connected for differential operation. If this bit is set, a single-ended cable is connected to the device's DIFFSENSE pin.

**Bit 1 LDSC (Last Disconnect)**

This bit is used in conjunction with the Connected (CON) bit in SCNTL1. It allows the user to detect the case in which a target device disconnects, and then some SCSI device selects or reselects the SYM53C876 SCSI function. If the Connected bit is asserted and the LDSC bit is asserted, a disconnect is indicated. This bit is set when the Connected bit in SCNTL1 is off. This bit is cleared when a Block Move instruction is executed while the Connected bit in SCNTL1 is on.

**Bit 0 SDP1 (SCSI SDP1 Signal)**

This bit represents the active-high current state of the SCSI SDP1 parity signal. It is unlatched and may change as it is read.

---

**Registers 10h-13h**  
**Data Structure Address (DSA)**  
*Read/Write*

This 32-bit register contains the base address used for all table indirect calculations. The DSA register is usually loaded prior to starting an I/O, but it is possible for a SCRIPTS Memory Move to load the DSA during the I/O.

During any Memory-to-Memory Move operation, the contents of this register are preserved. The power-up value of this register is indeterminate.

## Register 14h

### Interrupt Status (ISTAT)

*Read/Write*

ABRT	SRST	SIGP	SEM	CON	INTF	SIP	DIP
7	6	5	4	3	2	1	0
Default >>>							
0	0	0	0	0	0	0	0

This is the only register that is accessible by the host CPU while a SYM53C876 SCSI function is executing SCRIPTS (without interfering in the operation of the function). It polls for interrupts if hardware interrupts are disabled. Read this register after servicing an interrupt to check for stacked interrupts. For more information on interrupt handling refer to Chapter 2, “Functional Description.”

#### Bit 7 ABRT (Abort Operation)

Setting this bit aborts the current operation under execution by the SYM53C876 SCSI function. If this bit is set and an interrupt is received, reset this bit before reading the DSTAT register to prevent further aborted interrupts from being generated. The sequence to abort any operation is:

1. Set this bit.
2. Wait for an interrupt.
3. Read the ISTAT register.
4. If the SCSI Interrupt Pending bit is set, then read the SIST0 or SIST1 register to determine the cause of the SCSI Interrupt and go back to Step 2.
5. If the SCSI Interrupt Pending bit is clear, and the DMA Interrupt Pending bit is set, then write 00h value to this register.
6. Read the DSTAT register to verify the aborted interrupt and to see if any other interrupting conditions have occurred.

#### Bit 6 SRST (Software Reset)

Setting this bit resets the SYM53C876 SCSI function. All operating registers are cleared to

their respective default values and all SCSI signals are deasserted. Setting this bit does not assert the SCSI RST/ signal. This reset does not clear the ID Mode bit or any of the PCI configuration registers. This bit is not self-clearing; it must be cleared to clear the reset condition (a hardware reset also clears this bit).

#### Bit 5 SIGP (Signal Process)

SIGP is a R/W bit that is writable at any time, and polled and reset via CTEST2. The SIGP bit is used in various ways to pass a flag to or from a running SCRIPTS instruction.

The only SCRIPTS instruction directly affected by the SIGP bit is Wait For Selection/ Reselection. Setting this bit causes that instruction to jump to the alternate address immediately. The instructions at the alternate jump address should check the status of SIGP to determine the cause of the jump. The SIGP bit is usable at any time and is not restricted to the wait for selection/ reselection condition.

#### Bit 4 SEM (Semaphore)

The SCRIPTS processor may set this bit using a SCRIPTS register write instruction. An external processor may also set it while the SYM53C876 SCSI function is executing a SCRIPTS operation. This bit enables the SCSI function to notify an external processor of a predefined condition while SCRIPTS are running. The external processor may also notify the SYM53C876 SCSI function of a predefined condition and the SCRIPTS processor may take action while SCRIPTS are executing.

#### Bit 3 CON (Connected)

This bit is automatically set any time the SYM53C876 SCSI function is connected to the SCSI bus as an initiator or as a target. It is set after successfully completing selection or when the SYM53C876 SCSI function responds to a bus-initiated selection or reselection. It is also set after the SCSI function

wins arbitration when operating in low level mode. When this bit is clear, the SYM53C876 SCSI function is not connected to the SCSI bus.

**Bit 2 INTF (Interrupt on the Fly)**

This bit is asserted by an INTFLY instruction during SCRIPTS execution. SCRIPTS programs do not halt when the interrupt occurs. This bit can be used to notify a service routine, running on the main processor while the SCRIPTS processor is still executing a SCRIPTS program. If this bit is set, when the ISTAT register is read it is not automatically cleared. To clear this bit, write it to a one. The reset operation is self-clearing.

**Note:** If the INTF bit is set but SIP or DIP is not set, do not attempt to read the other chip status registers. An interrupt-on-the-fly interrupt must be cleared before servicing any other interrupts indicated by SIP or DIP.

**Note:** This bit must be written to one in order to clear it after it has been set.

**Bit 1 SIP (SCSI Interrupt Pending)**

This status bit is set when an interrupt condition is detected in the SCSI portion of the SYM53C876 SCSI function. The following conditions cause a SCSI interrupt to occur:

- A phase mismatch (initiator mode) or SATN/ becomes active (target mode)
- An arbitration sequence completes
- A selection or reselection time-out occurs
- The SYM53C876 SCSI function is selected
- The SYM53C876 SCSI function is reselected

- A SCSI gross error occurs
- An unexpected disconnect occurs
- A SCSI reset occurs
- A parity error is detected
- The handshake-to-handshake timer is expired
- The general purpose timer is expired.

To determine exactly which condition(s) caused the interrupt, read the SIST0 and SIST1 registers.

**Bit 0 DIP (DMA Interrupt Pending)**

This status bit is set when an interrupt condition is detected in the DMA portion of the SYM53C876 SCSI function. The following conditions cause a DMA interrupt to occur:

- A PCI parity error is detected
- A bus fault is detected
- An abort condition is detected
- A SCRIPTS instruction is executed in single-step mode
- A SCRIPTS interrupt instruction is executed
- An illegal instruction is detected.

To determine exactly which condition(s) caused the interrupt, read the DSTAT register.

**Register 18h**  
**Chip Test Zero (CTEST0)**  
*Read/Write*

RES	RES	RES	RES	RES	AP2	AP1	AP0
7	6	5	4	3	2	1	0

Default >>>

X X X X X 0 0 0

**Bits 7-3 Reserved**

**Bits 2-0 AP2-0 (Arbitration Priority 2-0)**

These bits are the priority used for gaining access to the PCI bus through the internal arbiter in the SYM53C876 SCSI function. Valid arbitration priority values are 0 (lowest priority) through 7 (highest priority).

**Register 19h**  
**Chip Test One (CTEST1)**  
*Read Only*

FMT3	FMT2	FMT1	FMT0	FFL3	FFL2	FFL1	FFL0
7	6	5	4	3	2	1	0

Default >>>

1 1 1 1 0 0 0 0

**Bits 7-4 FMT3-0 (Byte Empty in DMA FIFO)**

These bits identify the bottom bytes in the DMA FIFO that are empty. Each bit corresponds to a byte lane in the DMA FIFO. For example, if byte lane three is empty, then FMT3 is set. Since the FMT flags indicate the status of bytes at the bottom of the FIFO, if all FMT bits are set, the DMA FIFO is empty.

**Bits 3-0 FFL3-0 (Byte Full in DMA FIFO)**

These status bits identify the top bytes in the DMA FIFO that are full. Each bit corresponds to a byte lane in the DMA FIFO. For example, if byte lane three is full then FFL3 is set. Since the FFL flags indicate the status of bytes at the top of the FIFO, if all FFL bits are set, the DMA FIFO is full.

**Register 1Ah**  
**Chip Test Two (CTEST2)**  
*Read Only*

DDIR	SIGP	CIO	CM	SRTCH	TEOP	DREQ	DACK
7	6	5	4	3	2	1	0

Default >>>

0 0 X X 0 0 0 1

**Bit 7 DDIR (Data Transfer Direction)**

This status bit indicates which direction data is being transferred. When this bit is set, the data is transferred from the SCSI bus to the host bus. When this bit is clear, the data is transferred from the host bus to the SCSI bus.

**Bit 6 SIGP (Signal Process)**

This bit is a copy of the SIGP bit in the ISTAT register (bit 5). The SIGP bit signals a running SCRIPTS instruction. When this register is read, the SIGP bit in the ISTAT register is cleared.

**Bit 5 CIO (Configured as I/O)**

This bit is defined as the Configuration I/O Enable Status bit. This read-only bit indicates if the chip is currently enabled as I/O space.

Note: Both bits 4 and 5 may be set if the chip is dual-mapped.

**Bit 4 CM (Configured as Memory)**

This bit is defined as the configuration memory enable status bit. This read-only bit indicates if the chip is currently enabled as memory space.

Note: Both bits 4 and 5 may be set if the chip is dual-mapped.

**Bit 3 SRTCH (SCRATCHA/B Operation)**

This bit controls the operation of the SCRATCHA and SCRATCHB registers. When it is set, SCRATCHB contains the RAM base address value from the PCI configuration RAM Base Address register. This is the base address for the 4 KB internal RAM.

In addition, the SCRATCHA register displays the memory-mapped based address of the chip operating registers. When this bit is cleared, the SCRATCHA and SCRATCHB registers return to normal operation.

Note: Bit 3 is the only writable bit in this register. All other bits are read only. When modifying this register, all other bits must be written to zero. Do not execute a Read-Modify-Write to this register.

**Bit 2 TEOP (SCSI True End of Process)**

This bit indicates the status of the SYM53C876 SCSI function's internal TEOP signal. The TEOP signal acknowledges the completion of a transfer through the SCSI portion of the SYM53C876 SCSI function. When this bit is set, TEOP is active. When this bit is clear, TEOP is inactive.

**Bit 1 DREQ (Data Request Status)**

This bit indicates the status of the SYM53C876 SCSI function's internal Data Request signal (DREQ). When this bit is set, DREQ is active. When this bit is clear, DREQ is inactive.

**Bit 0 DACK (Data Acknowledge Status)**

This bit indicates the status of the SYM53C876 SCSI function's internal Data Acknowledge signal (DACK/). When this bit is set, DACK/ is inactive. When this bit is clear, DACK/ is active.



---

**Register 1Bh**  
**Chip Test Three (CTEST3)**  
*Read/Write*

V3	V2	V1	V0	FLF	CLF	FM	WRIE
7	6	5	4	3	2	1	0

Default &gt;&gt;&gt;

X	X	X	X	0	0	0	0
---	---	---	---	---	---	---	---

**Bits 7-4 V3-V0 (Chip Revision Level)**

These bits identify the chip revision level for software purposes. It should have the same value as the lower nibble of the PCI Revision ID register.

**Bit 3 FLF (Flush DMA FIFO)**

When this bit is set, data residing in the DMA FIFO is transferred to memory, starting at the address in the DNAD register. The internal DMAWR signal, controlled by the CTEST5 register, determines the direction of the transfer. This bit is not self clearing; reset it once the data is successfully transferred by the SYM53C876 SCSI function.

Note: Polling of FIFO flags is allowed during flush operations.

**Bit 2 CLF (Clear DMA FIFO)**

When this bit is set, all data pointers for the DMA FIFO are cleared. Any data in the FIFO is lost. After the SYM53C876 SCSI function successfully clears the appropriate FIFO pointers and registers, this bit automatically resets.

Note: This bit does not clear the data visible at the bottom of the FIFO.

**Bit 1 FM (Fetch Pin Mode)**

When set, this bit causes the FETCH/ pin to deassert during indirect and table indirect read operations. FETCH/ is only active during the op code portion of an instruction fetch. This allows the storage of SCRIPTS in a PROM while data tables are stored in RAM.

If this bit is not set, FETCH/ is asserted for all bus cycles during instruction fetches.

**Bit 0 WRIE (Write and Invalidate Enable)**

This bit, when set, causes the issuing of Write and Invalidate commands on the PCI bus whenever legal. The Write and Invalidate Enable bit in the PCI Configuration Command register must also be set in order for the chip to generate Write and Invalidate commands.

**Registers 1Ch-1Fh**  
**Temporary (TEMP)**  
**Read/Write**

This 32-bit register stores the Return instruction address pointer from the Call instruction. The address pointer stored in this register is loaded into the DSP register when a Return instruction is executed. This address points to the next instruction to execute. Do not write to this register while the SYM53C876 SCSI function is executing SCRIPTS.

During any Memory-to-Memory Move operation, the contents of this register are preserved. The power-up value of this register is indeterminate.

**Register 20h**  
**DMA FIFO (DFIFO)**  
**Read/Write**

B07	B06	B05	B04	B03	B02	B01	B00
7	6	5	4	3	2	1	0
Default >>>							
0	0	0	0	0	0	0	0

**Bits 7-0 BO7-BO0 (Byte offset counter)**

These bits, along with bits 1-0 in the CTEST5 register, indicate the amount of data transferred between the SCSI core and the DMA core. It determines the number of bytes in the DMA FIFO when an interrupt occurs. These bits are unstable while data is being transferred between the two cores. Once the chip has stopped transferring data, these bits are stable.

The DFIFO register counts the number of bytes transferred between the DMA core and the SCSI core. The DBC register counts the number of bytes transferred across the host bus. The difference between these two counters represents the number of bytes remaining in the DMA FIFO.

The following steps determine how many bytes are left in the DMA FIFO when an error occurs, regardless of the transfer direction:

1. If the DMA FIFO size is set to 88 bytes, subtract the seven least significant bits of the DBC register from the 7-bit value of the DFIFO register. If the DMA FIFO size is set to 536 bytes (using bit 5 of the CTEST register), subtract the 10 least significant bits of the DBC register from the 10-bit value of the DMA FIFO Byte Offset Counter, which is made up of the CTEST register (bits 1 and 0) and the DFIFO register (bits 7-0).
2. If the DMA FIFO size is set to 88 bytes, AND the result with 7Fh for a byte count between zero and 64. If the DMA FIFO size is set to 536 bytes, AND the result with 3FFh for a byte count between zero and 536.

**Register 21h**  
**Chip Test Four (CTEST4)**  
*Read/Write*

BDIS	ZMOD	ZSD	SRTM	MPEE	FBL2	FBL1	FBL0
7	6	5	4	3	2	1	0

Default >>>

0 0 0 0 0 0 0 0

**Bit 7 BDIS (Burst Disable)**

When set, this bit causes the SYM53C876 SCSI function to perform back-to-back cycles for all transfers. When this bit is reset, back-to-back transfers for op code fetches and burst transfers for data moves are performed.

**Bit 6 ZMOD (High Impedance Mode)**

Setting this bit causes the SYM53C876 SCSI function to place all output and bidirectional pins into a high-impedance state. In order to read data out of the SYM53C876 SCSI function, this bit must be cleared. This bit is intended for board-level testing only. Do not set this bit during normal system operation. To use this feature set the bit in both SCSI Function A and SCSI Function B.

**Bit 5 ZSD (SCSI Data High Impedance)**

Setting this bit causes the SYM53C876 SCSI function to place the SCSI data bus SD(15-0) and the parity lines SDP(1-0) in a high-impedance state. In order to transfer data on the SCSI bus, clear this bit.

**Bit 4 SRTM (Shadow Register Test Mode)**

Setting this bit allows access to the shadow registers used by memory-to-memory Move operations. When this bit is set, register accesses to the TEMP and DSA registers are directed to the shadow copies STEMP (Shadow TEMP) and SDSA (Shadow DSA). The registers are shadowed to prevent them from being overwritten during a Memory-to-Memory Move operation. The DSA and TEMP registers contain the base address used for table indirect calculations, and the address

pointer for a call or return instruction, respectively. This bit is intended for manufacturing diagnostics only and should not be set during normal operations.

**Bit 3 MPEE (Master Parity Error Enable)**

Setting this bit enables parity checking during master data phases. A parity error during a bus master read is detected by the SYM53C876 SCSI function. A parity error during a bus master write is detected by the target, and the SYM53C876 SCSI function is informed of the error by the PERR/ pin being asserted by the target. When this bit is reset, the SYM53C876 SCSI function does not interrupt if a master parity error occurs. This bit is reset at power up.

**Bits 2-0 FBL2-FBL0 (FIFO Byte Control)**

FBL2	FBL1	FBL0	DMA FIFO Byte lane	Pins
0	X	X	Disabled	n/a
1	0	0	0	D(7-0)
1	0	1	1	D(15-8)
1	1	0	2	D(23-16)
1	1	1	3	D(31-24)

These bits steer the contents of the CTEST6 register to the appropriate byte lane of the 32-bit DMA FIFO. If the FBL2 bit is set, then FBL1 and FBL0 determine which of four byte lanes can be read or written. When cleared, the byte lane which is read or written is determined by the current contents of the DNAD and DBC registers. Each of the four bytes that make up the 32-bit DMA FIFO is accessed by writing these bits to the proper value. For normal operation, FBL2 must equal zero.

**Register 22h**  
**Chip Test Five (CTEST5)**  
*Read/Write*

ADCK	BBCK	DFS	MASR	DDIR	BL2	BO9	BO8
7	6	5	4	3	2	1	0
Default >>>							
0	0	0	0	0	0	0	0

**Bit 7 ADCK (Clock Address Incrementor)**

Setting this bit increments the address pointer contained in the DNAD register. The DNAD register is incremented based on the DNAD contents and the current DBC value. This bit automatically clears itself after incrementing the DNAD register.

**Bit 6 BBCK (Clock Byte Counter)**

Setting this bit decrements the byte count contained in the 24-bit DBC register. It is decremented based on the DBC contents and the current DNAD value. This bit automatically clears itself after decrementing the DBC register.

**Bit 5 DFS (DMA FIFO Size)**

This bit controls the size of the DMA FIFO. When clear, the DMA FIFO appears as only 88 bytes deep. When set, the DMA FIFO size increases to 536 bytes. Using an 88-byte FIFO allows software written for other SYM53C8XX family chips to properly calculate the number of bytes residing in the chip after a target disconnect. The default value of this bit is zero.

**Bit 4 MASR (Master Control for Set or Reset Pulses)**

This bit controls the operation of bit 3. When this bit is set, bit 3 asserts the corresponding signals. When this bit is reset, bit 3 deasserts the corresponding signals. Do **not** change this bit and bit 3 in the same write cycle.

**Bit 3 DDIR (DMA Direction)**

Setting this bit either asserts or deasserts the internal DMA Write (DMAWR) direction signal depending on the current status of the MASR bit in this register. Asserting the DMAWR signal indicates that data is transferred from the SCSI bus to the host bus. Deasserting the DMAWR signal transfers data from the host bus to the SCSI bus.

**Bit BL2 (Burst Length bit 2)**

This bit works with bits 6 and 7 in the DMODE register to determine the burst length. For complete definitions of this field, refer to the descriptions of DMODE bits 6 and 7. This bit is disabled if an 88-byte FIFO is selected by clearing the DMA FIFO Size bit.

**Bits 1-0 BO9-BO8 (DMA FIFO Byte Offset Counter, bits 9-8)**

These are the upper two bits of the DFBOC. Refer to the DFBOC register description for encodings of the BO9-0 bits.

### Register 23h

#### Chip Test Six (CTEST6)

*Read/Write*

DF7	DF6	DF5	DF4	DF3	DF2	DF1	DF0
7	6	5	4	3	2	1	0

Default >>>

0 0 0 0 0 0 0 0

#### Bits 7-0 DF7-DF0 (DMA FIFO)

Writing to this register writes data to the appropriate byte lane of the DMA FIFO as determined by the FBL bits in the CTEST4 register. Reading this register unloads data from the appropriate byte lane of the DMA FIFO as determined by the FBL bits in the CTEST4 register. Data written to the FIFO is loaded into the top of the FIFO. Data read out of the FIFO is taken from the bottom. To prevent DMA data from being corrupted, this register should not be accessed before starting or restarting SCRIPTS operation. Write this register only when testing the DMA FIFO using the CTEST4 register. Writing to this register while the test mode is not enabled produces unexpected results.

### Registers 24h-26h

#### DMA Byte Counter (DBC)

*Read/Write*

This 24-bit register determines the number of bytes transferred in a Block Move instruction. While sending data to the SCSI bus, the counter is decremented as data is moved into the DMA FIFO from memory. While receiving data from the SCSI bus, the counter is decremented as data is written to memory from the SYM53C876 SCSI function. The DBC counter is decremented each time data is transferred on the PCI bus. It is decremented by an amount equal to the number of bytes that are transferred.

The maximum number of bytes that can be transferred in any one Block Move command is 16,777,215 bytes. The maximum value that can be loaded into the DBC register is FFFFFFFh. If the instruction is a Block Move and a value of 000000h is loaded into the DBC register, an illegal instruction interrupt occurs if the SYM53C876 SCSI function is not in target mode, Command phase.

The DBC register also holds the least significant 24 bits of the first dword of a SCRIPTS fetch, and to hold the offset value during table indirect I/O SCRIPTS. For a complete description see Chapter 5, *SCSI SCRIPTS Instruction Set*. The power-up value of this register is indeterminate.

---

**Register 27h**  
**DMA Command (DCMD)**  
*Read/Write*

This 8-bit register determines the instruction for the SYM53C876 SCSI function to execute. This register has a different format for each instruction. For a complete description see Chapter 5, *SCSI SCRIPTS Instruction Set*.

---

**Registers 28h-2Bh**  
**DMA Next Address (DNAD)**  
*Read/Write*

This 32-bit register contains the general purpose address pointer. At the start of some SCRIPTS operations, its value is copied from the DSPS register. Its value may not be valid except in certain abort conditions. The default value of this register is zero.

---

**Registers 2Ch-2Fh**  
**DMA SCRIPTS Pointer (DSP)**  
*Read/Write*

To execute SCSI SCRIPTS, the address of the first SCRIPTS instruction must be written to this register. In normal SCRIPTS operation, once the starting address of the SCRIPT is written to this register, SCRIPTS are automatically fetched and executed until an interrupt condition occurs.

In single-step mode, there is a single step interrupt after each instruction is executed. The DSP register does not need to be written with the next address, but the Start DMA bit (bit 2, DCNTL register) must be set each time the step interrupt occurs to fetch and execute the next SCRIPTS command. When writing this register eight bits at a time, writing the upper eight bits begins execution of SCSI SCRIPTS. The default value of this register is zero.

---

**Registers 30h-33h**  
**DMA SCRIPTS Pointer Save (DSPS)**  
*Read/Write*

This register contains the second longword of a SCRIPTS instruction. It is overwritten each time a SCRIPTS instruction is fetched. When a SCRIPTS interrupt instruction is executed, this register holds the interrupt vector. The power-up value of this register is indeterminate.

### Registers 34h Scratch Register A (SCRATCHA) *Read/Write*

This is a general purpose, user-definable scratch pad register. Apart from CPU access, only Register Read/Write and Memory Moves into the SCRATCH register alter its contents. The power-up value of this register is indeterminate.

A special mode of this register is enabled by setting the BAE bit in the CTEST5 register. If this bit is set, the SCRATCHA register returns the memory base address of the chip registers on the upper 24 bits of the data bus when the SCRATCHA register is read. Writes to the SCRATCHA register are unaffected. Resetting the BAE bit causes the SCRATCHA register to return to normal operation.

### Register 38h DMA Mode (DMODE) *Read/Write*

BL1	BL0	SIOM	DIOM	ER	ERMP	BOF	MAN
7	6	5	4	3	2	1	0
Default >>>							
0	0	0	0	0	0	0	0

#### Bit 7-6 BL1-BL0 (Burst Length)

These bits control the maximum number of transfers performed per bus ownership, regardless of whether the transfers are back-to-back, burst, or a combination of both. The SYM53C876 SCSI function asserts the Bus Request (REQ/) output when the DMA FIFO can accommodate a transfer of at least one burst size of data. Bus Request (REQ/) is also asserted during start-of-transfer and end-of-transfer cleanup and alignment, even if less than a full burst of transfers is performed. The SYM53C876 SCSI function inserts a “fairness delay” of four CLKs between burst-length transfers (as set in BL1-0) during normal operation. The fairness delay is not inserted during PCI retry cycles. This gives the CPU and other bus master devices the opportunity to access the PCI bus between bursts.

BL2 (CTEST5 bit 2)	BL1	BL0	Burst Length
0	0	0	2- transfer burst
0	0	1	4- transfer burst
0	1	0	8-transfer burst
0	1	1	16-transfer burst
1	0	0	32-transfer burst*
1	0	1	64-transfer burst*
1	1	0	128-transfer burst*
1	1	1	Reserved

\*The 536 Byte FIFO must be enabled for these burst sizes



**Bit 5 SIOM (Source I/O-Memory Enable)**

This bit is defined as an I/O Memory Enable bit for the source address of a Memory Move or Block Move Command. If this bit is set, then the source address is in I/O space; and if reset, then the source address is in memory space.

This function is useful for register-to-memory operations using the Memory Move instruction when a SYM53C876 SCSI function is I/O mapped. Bits 4 and 5 of the CTEST2 register determine the configuration status of the SYM53C876 SCSI function SCSI function.

**Bit 4 DIOM (Destination I/O-Memory Enable)**

This bit is defined as an I/O Memory Enable bit for the destination address of a Memory Move or Block Move Command. If this bit is set, then the destination address is in I/O space; and if reset, then the destination address is in memory space.

This function is useful for memory-to-register operations using the Memory Move instruction when a SYM53C876 SCSI function is I/O mapped. Bits 4 and 5 of the CTEST2 register determine the configuration status of the SYM53C876 SCSI function.

**Bit 3 ERL (Enable Read Line)**

This bit enables a PCI Read Line command. If this bit is set and the chip is about to execute a read cycle other than an op code fetch, then the command is 1110.

**Bit 2 ERMP (Enable Read Multiple)**

If this bit is set and cache mode is enabled, a Read Multiple command is used on all read cycles when it is legal.

**Bit 1 BOF (Burst Op Code Fetch Enable)**

Setting this bit causes the SYM53C876 SCSI function to fetch instructions in burst mode. Specifically, the chip bursts in the first two longwords of all instructions using a single bus

ownership. If the instruction is a memory-to-memory move type, the third longword is accessed in a subsequent bus ownership. If the instruction is an indirect type, the additional longword is accessed in a subsequent bus ownership. If the instruction is a table indirect block move type, the chip accesses the remaining two longwords in a subsequent bus ownership, thereby fetching the four longwords required in two bursts of two longwords each. If prefetch is enabled, this bit has no effect. This bit also has no effect on fetches out of SCRIPT RAM.

**Bit 0 MAN (Manual Start Mode)**

Setting this bit prevents the SYM53C876 SCSI function from automatically fetching and executing SCSI SCRIPTS when the DSP register is written. When this bit is set, the Start DMA bit in the DCNTL register must be set to begin SCRIPTS execution. Clearing this bit causes the SYM53C876 SCSI function to automatically begin fetching and executing SCSI SCRIPTS when the DSP register is written. This bit normally is not used for SCSI SCRIPTS operations.

**Register 39h**  
**DMA Interrupt Enable (DIEN)**  
*Read/Write*

RES	MDPE	BF	ABRT	SSI	SIR	RES	IID
7	6	5	4	3	2	1	0
Default >>>							
X	0	0	0	0	0	X	0

This register contains the interrupt mask bits corresponding to the interrupting conditions described in the DSTAT register. An interrupt is masked by clearing the appropriate mask bit. Masking an interrupt prevents INTA/ (for Function A) or INTB/ (for Function B) from being asserted for the corresponding interrupt, but the status bit is still set in the DSTAT register. Masking an interrupt does not prevent setting the ISTAT DIP. All DMA interrupts are considered fatal, therefore SCRIPTS stops running when this condition occurs, whether or not the interrupt is masked. Setting a mask bit enables the assertion of INTA/, or INTB/, for the corresponding interrupt. (A masked non-fatal interrupt does not prevent un-masked or fatal interrupts from getting through; interrupt stacking begins when either the ISTAT SIP or DIP bit is set.)

The INTA/ and INTB/ outputs are latched. Once asserted, they remain asserted until the interrupt is cleared by reading the appropriate status register. Masking an interrupt after the INTA/, or INTB/, output is asserted does not cause deassertion of INTA/, or INTB/.

For more information on interrupts, see Chapter 2, *Functional Description*.

- Bit 7    Reserved**
- Bit 6    MDPE (Master Data Parity Error)**
- Bit 5    BF (Bus Fault)**
- Bit 4    ABRT (Aborted)**
- Bit 3    SSI (Single -step Interrupt)**
- Bit 2    SIR (SCRIPTS Interrupt Instruction Received)**

- Bit 1    Reserved**
- Bit 0    IID (Illegal Instruction Detected)**

### Register 3Ah

#### Scratch Byte Register (SBR)

*Read/Write*

This is a general purpose register. Apart from CPU access, only Register Read/Write and Memory Moves into this register alter its contents. The default value of this register is zero. This register is called the DMA Watchdog Timer on previous SYM53C8XX family products.

### Register 3Bh

#### DMA Control (DCNTL)

*Read/Write*

CLSE	PFF	PFEN	SSM	INTM	STD	INTD	COM
7	6	5	4	3	2	1	0

Default >>>

0 0 0 0 0 0 0 0

#### Bit 7 CLSE (Cache Line Size Enable)

Setting this bit enables the SYM53C876 SCSI function to sense and react to cache line boundaries set up by the DMODE or PCI Cache Line Size register, whichever contains the smaller value. Clearing this bit disables the cache line size logic and the SYM53C876 SCSI function monitors the cache line size via the DMODE register.

#### Bit 6 PFF (Pre-fetch Flush)

Setting this bit causes the pre-fetch unit to flush its contents. The bit resets after the flush is complete.

#### Bit 5 PFEN (Pre-fetch Enable)

Setting this bit enables the pre-fetch unit if the burst size is equal to or greater than four. For more information on SCRIPTS instruction prefetching, see Chapter 2.

#### Bit 4 SSM (Single-step Mode)

Setting this bit causes the SYM53C876 SCSI function to stop after executing each SCRIPTS instruction, and generate a single step interrupt. When this bit is clear the SYM53C876 SCSI function does not stop after each instruction. It continues fetching and executing instructions until an interrupt condition occurs. For normal SCSI SCRIPTS operation, keep this bit clear. To restart the SYM53C876 SCSI function after it generates a SCRIPTS Step interrupt, read the ISTAT and DSTAT registers to recognize and clear the interrupt. Then set the START DMA bit in this register.

**Bit 3 INTM (INTA Mode)**

When set, this bit enables a totem pole driver for the INTA/, or INTB/ pin. When reset, this bit enables an open drain driver for the INTA/, or INTB/, pin with an internal weak pull-up. This bit is reset at power up. The bit should remain clear to retain full PCI compliance.

**Bit 2 STD (Start DMA Operation)**

The SYM53C876 SCSI function fetches a SCSI SCRIPTS instruction from the address contained in the DSP register when this bit is set. This bit is required if the SYM53C876 SCSI function is in one of the following modes:

1. Manual start mode – Bit 0 in the DMODE register is set
2. Single-step mode – Bit 4 in the DCNTL register is set

When the SYM53C876 SCSI function is executing SCRIPTS in manual start mode, the Start DMA bit must be set to start instruction fetches, but need not be set again until an interrupt occurs. When the SYM53C876 SCSI function is in single-step mode, set the Start DMA bit to restart execution of SCRIPTS after a single-step interrupt.

**Bit 1 IRQD (INTA, INTB Disable)**

Setting this bit disables the INTA (for SCSI Function A), or INTB (for SCSI Function B) pin. Clearing the bit enables normal operation. As with any other register other than ISTAT, this register cannot be accessed except by a SCRIPTS instruction during SCRIPTS execution. For more information on the use of this bit in interrupt handling, see Chapter 2.

**Bit 0 COM (53C700 Compatibility)**

When the COM bit is clear, the SYM53C876 SCSI function behaves in a manner compatible with the SYM53C700; selection/reselection IDs are stored in both the SSID and SFBR registers. This bit is not effected by a software reset.

If the COM bit is cleared, do not access this register via SCRIPTS operation as non-determinate operations may occur. (This includes SCRIPTS Read/Write operations and conditional transfer control instructions that initialize the SFBR register.)

When the COM bit is set, the ID is stored only in the SSID register, protecting the SFBR from being overwritten if a selection/reselection occurs during a DMA register-to-register operation.

**Register 3Ch-3Fh**  
**Adder Sum Output (ADDER)**  
*Read Only*

This register contains the output of the internal adder, and is used primarily for test purposes. The power-up value for this register is indeterminate.

**Register 40h**  
**SCSI Interrupt Enable Zero (SIEN0)**  
*Read/Write*

M/A	CMP	SEL	RSL	SGE	UDC	RST	PAR
7	6	5	4	3	2	1	0
Default >>>							
0	0	0	0	0	0	0	0

This register contains the interrupt mask bits corresponding to the interrupting conditions described in the SIST0 register. An interrupt is masked by clearing the appropriate mask bit. For more information on interrupts, see Chapter 2, *Functional Description*.

**Bit 7 M/A (SCSI Phase Mismatch - Initiator Mode; SCSI ATN Condition - Target Mode)**

Setting this bit allows the SYM53C876 to generate an interrupt when a Phase Mismatch or ATN condition occurs. In initiator mode, this bit is set when the SCSI phase asserted by the target and sampled during SREQ/ does not match the expected phase in the SOCL register. This expected phase is automatically written by SCSI SCRIPTS. In target mode, this bit is set when the initiator asserts SATN/ . See the Disable Halt on Parity Error or SATN/ Condition bit in the SCNTL1 register for more information on when this status is actually raised.

**Bit 6 CMP (Function Complete)**

Setting this bit allows the SYM53C876 to generate an interrupt when a full arbitration and selection sequence has completed.

**Bit 5 SEL (Selected)**

Setting this bit allows the SYM53C876 to generate an interrupt when the SYM53C876 has been selected by another SCSI device. Set the Enable Response to Selection bit in the SCID register for this to occur.

**Bit 4 RSL (Reselected)**

Setting this bit allows the SYM53C876 to generate an interrupt when the SYM53C876 has been reselected by another SCSI device. Set the Enable Response to Reselection bit in the SCID register for this to occur.

**Bit 3 SGE (SCSI Gross Error)**

Setting this bit allows the SYM53C876 to generate an interrupt when a SCSI gross error occurs. The following conditions are considered SCSI Gross Errors:

1. Data underflow - the SCSI FIFO was read when no data is present.
2. Data overflow - the SCSI FIFO was written while it is full.
3. Offset underflow - in target mode, a SACK/ pulse was received before the corresponding SREQ/ is sent.
4. Offset overflow - in initiator mode, an SREQ/ pulse was received which caused the maximum offset (defined by the MO3-0 bits in the SXFER register) to be exceeded.
5. In initiator mode, a phase change occurred with an outstanding SREQ/SACK offset.
6. Residual data in SCSI FIFO - a transfer other than synchronous data receive was started with data left in the SCSI synchronous receive FIFO.

**Bit 2 UDC (Unexpected Disconnect)**

Setting this bit allows the SYM53C876 to generate an interrupt when an unexpected disconnect occurs. This condition only occurs in initiator mode. It happens when the target to which the SYM53C876 is connected disconnects from the SCSI bus unexpectedly. See the SCSI Disconnect Unexpected bit in the SCNTL2 register for more information on expected versus unexpected disconnects. Any disconnect in low level mode causes this condition.

**Bit 1 RST (SCSI Reset Condition)**

Setting this bit allows the SYM53C876 to generate an interrupt when the SRST/ signal has been asserted by the SYM53C876 or any other SCSI device. This condition is edge-triggered, so multiple interrupts cannot occur because of a single SRST/ pulse.

**Bit 0 PAR (SCSI Parity Error)**

Setting this bit allows the SYM53C876 to generate an interrupt when the SYM53C876 detects a parity error while receiving or sending SCSI data. See the Disable Halt on Parity Error or SATN/ Condition bits in the SCNTL1 register for more information on when this condition is actually raised.

## Register 41h

### SCSI Interrupt Enable One (SIEN1)

*Read/Write*

RES	RES	RES	RES	WIE	STO	GEN	HTH
7	6	5	4	3	2	1	0

Default >>>

X X X X 0 0 0 0

This register contains the interrupt mask bits corresponding to the interrupting conditions described in the SIST1 register. An interrupt is masked by clearing the appropriate mask bit. For more information on interrupts, refer to Chapter 2, *Functional Description*.

#### Bits 7-4 Reserved

#### Bit 3 WIE (Wakeup Interrupt Enable)

Setting this bit allows the SYM53C876E to enable /IRQ on SCSI reset.

#### Bit 2 STO (Selection or Reselection Time-out)

Setting this bit allows the SYM53C876 to generate an interrupt when a selection or reselection time-out occurs. See the description of the STIME0 register bits 3-0 for more information on the time-out periods.

#### Bit 1 GEN (General Purpose Timer Expired)

Setting this bit allows the SYM53C876 to generate an interrupt when the general purpose timer has expired. The time measured is the time between enabling and disabling of the timer. See the description of the STIME1 register, bits 3-0, for more information on the general purpose timer.

#### Bit 0 HTH (Handshake-to-Handshake Timer Expired)

Setting this bit allows the SYM53C876 to generate an interrupt when the handshake-to-handshake timer has expired. The time measured is the SCSI Request-to-Request (target) or Acknowledge-to-Acknowledge (initiator)

period. See the description of the STIME0 register, bits 7-4, for more information on the handshake-to-handshake timer.

**Register 42h**  
**SCSI Interrupt Status Zero (SIST0)**  
*Read Only*

M/A	CMP	SEL	RSL	SGE	UDC	RST	PAR
7	6	5	4	3	2	1	0
Default >>>							
0	0	0	0	0	0	0	0

Reading the SIST0 register returns the status of the various interrupt conditions, whether they are enabled in the SIEN0 register or not. Each bit set indicates occurrence of the corresponding condition. Reading the SIST0 clears the interrupt status.

Reading this register clears any bits that are set at the time the register is read, but does not necessarily clear the register because additional interrupts may be pending (the SYM53C876 SCSI functions stack interrupts). SCSI interrupt conditions are individually masked through the SIEN0 register.

When performing consecutive 8-bit reads of the DSTAT, SIST0, and SIST1 registers (in any order), insert a delay equivalent to 12 CLK periods between the reads to ensure the interrupts clear properly. Also, if reading the registers when both the ISTAT SIP and DIP bits may not be set, read the SIST0 and SIST1 registers before the DSTAT register to avoid missing a SCSI interrupt. For more information on interrupts, refer to Chapter 2, "Functional Description."

**Bit 7 M/A (Initiator Mode: Phase Mismatch; Target Mode: SATN/ Active)**

In initiator mode, this bit is set if the SCSI phase asserted by the target does not match the instruction. The phase is sampled when SREQ/ is asserted by the target. In target mode, this bit is set when the SATN/ signal is asserted by the initiator.

**Bit 6 CMP (Function Complete)**

This bit is set when an arbitration only or full arbitration sequence is completed.

**Bit 5 SEL (Selected)**

This bit is set when the SYM53C876 SCSI function is selected by another SCSI device. The Enable Response to Selection bit must be set in the SCID register (and the RESPID register must hold the chip's ID) for the SYM53C876 SCSI function to respond to selection attempts.

**Bit 4 RSL (Reselected)**

This bit is set when the SYM53C876 SCSI function is reselected by another SCSI device. The Enable Response to Reselection bit must be set in the SCID register (and the RESPID register must hold the chip's ID) for the SYM53C876 SCSI function to respond to reselection attempts.

**Bit 3 SGE (SCSI Gross Error)**

This bit is set when the SYM53C876 SCSI function encounters a SCSI Gross Error Condition. The following conditions can result in a SCSI Gross Error Condition:

1. Data Underflow - reading the SCSI FIFO register when no data is present.
2. Data Overflow - writing too many bytes to the SCSI FIFO, or the synchronous offset causes overwriting the SCSI FIFO.
3. Offset Underflow - the SYM53C876 SCSI function is operating in target mode and a SACK/ pulse is received when the outstanding offset is zero.
4. Offset Overflow - the other SCSI device sends a SREQ/ or SACK/ pulse with data which exceeds the maximum synchronous offset defined by the SXFER register.
5. A phase change occurs with an outstanding synchronous offset when the SYM53C876 SCSI function is operating as an initiator.
6. Residual data in the Synchronous data FIFO - a transfer other than synchronous data receive is started with data left in the synchronous data FIFO.



**Bit 2 UDC (Unexpected Disconnect)**

This bit is set when the SYM53C876 SCSI function is operating in initiator mode and the target device unexpectedly disconnects from the SCSI bus. This bit is only valid when the SYM53C876 SCSI function operates in the initiator mode. When the SCSI function operates in low level mode, any disconnect causes an interrupt, even a valid SCSI disconnect. This bit is also set if a selection time-out occurs (it may occur before, at the same time, or stacked after the STO interrupt, since this is not considered an expected disconnect).

**Bit 1 RST (SCSI RST/ Received)**

This bit is set when the SYM53C876 SCSI function detects an active SRST/ signal, whether the reset is generated external to the chip or caused by the Assert SRST/ bit in the SCNTL1 register. This SCSI reset detection logic is edge-sensitive, so that multiple interrupts are not generated for a single assertion of the SRST/ signal.

**Bit 0 PAR (Parity Error)**

This bit is set when the SYM53C876 SCSI function detects a parity error while receiving SCSI data. The Enable Parity Checking bit (bit 3 in the SCNTL0 register) must be set for this bit to become active. The SYM53C876 SCSI function always generates parity when sending SCSI data.

**Register 43h**  
**SCSI Interrupt Status One (SIST1)**  
*Read Only*

RES	RES	RES	RES	RES	STO	GEN	HTH
7	6	5	4	3	2	1	0

Default >>>

X X X X 0 0 0 0

Reading the SIST1 register returns the status of the various interrupt conditions, whether they are enabled in the SIEN1 register or not. Each bit that is set indicates an occurrence of the corresponding condition.

Reading the SIST1 clears the interrupt condition.

**Bits 7-4 Reserved**

**Bit 2 STO (Selection or Reselection Time-out)**

The SCSI device which the SYM53C876 SCSI function is attempting to select or reselect does not respond within the programmed time-out period. See the description of the STIME0 register, bits 3-0, for more information on the time-out timer.

**Bit 1 GEN (General Purpose Timer Expired)**

This bit is set when the general purpose timer expires. The time measured is the time between enabling and disabling of the timer. See the description of the STIME1 register, bits 3-0, for more information on the general purpose timer.

**Bit 0 HTH (Handshake-to-Handshake Timer Expired)**

This bit is set when the handshake-to-handshake timer expires. The time measured is the SCSI Request to Request (target) or Acknowledge to Acknowledge (initiator) period. See the description of the STIME0 register, bits 7-4, for more information on the handshake-to-handshake timer.

**Register 44h**  
**SCSI Longitudinal Parity (SLPAR)**  
*Read/Write*

This register performs a bitwise longitudinal parity check on all SCSI data received or sent through the SCSI core. If one of the bytes received or sent (usually the last) is the set of correct even parity bits, SLPAR should go to zero (assuming it started at zero). As an example, suppose that the following three data bytes and one check byte are received from the SCSI bus (all signals are shown active high):

Data Bytes	Running SLPAR
---	00000000
1. 11001100	11001100 (XOR of word 1)
2. 01010101	10011001 (XOR of word 1 and 2)
3. 00001111	10010110 (XOR of word 1, 2 and 3) Even Parity >>>10010110
4. 10010110	00000000

A one in any bit position of the final SLPAR value would indicate a transmission error.

The SLPAR register also generates the check bytes for SCSI send operations. If the SLPAR register contains all zeros prior to sending a block move, it contains the appropriate check byte at the end of the block move. This byte must then be sent across the SCSI bus.

**Note:** Writing any value to this register resets it to zero.

The longitudinal parity checks are meant to provide an added measure of SCSI data integrity and are entirely optional. This register does not latch SCSI selection/reselection IDs under any circumstances. The default value of this register is zero.

The longitudinal parity function normally operates as a byte function. During 16-bit transfers, the high and low bytes are XORed together and then XORed into the current longitudinal parity value. By setting the SLPMD bit in the SCNTL3 register, the longitudinal parity function is made

to operate as a word-wide function. During 16-bit transfers, the high byte of the SCSI bus is XORed with the high byte of the current longitudinal parity value, and the low byte of the SCSI bus is XORed with the low byte of the current longitudinal parity value. In this mode, the 16-bit longitudinal parity value is accessed a byte at a time through the SLPAR register. Which byte is accessed is controlled by the SLPHBEN bit in the SCNTL3 register.

---

**Register 45h**  
**SCSI Wide Residue (SWIDE)**  
*Read/Write*

After a wide SCSI data receive operation, this register contains a residual data byte if the last byte received was never sent across the DMA bus. It represents either the first data byte of a subsequent data transfer, or it is a residue byte which should be cleared when an Ignore Wide Residue message is received. It may also be an overrun data byte. The power-up value of this register is indeterminate.

**Register 46h**  
**Memory Access Control (MACNTL)**  
*Read/Write*

TYP3	TYP2	TYP1	TYP0	RES	RES	RES	RES
7	6	5	4	3	2	1	0
Default >>>							
0	1	1	1	X	X	X	X

**Bits 7-4 TYP3-0 (Chip Type)**

These bits identify the chip type for software purposes. This data manual applies to devices that have these bits set to 70h.

**Bit 3-0 Reserved**

**Register 47h**  
**General Purpose Pin Control (GPCNTL)**  
*Read/Write*

ME	FE	RES	GPIO4	GPIO3	GPIO2	GPIO1	GPIO0
7	6	5	4	3	2	1	0
Default >>>							
0	0	X	0	1	1	1	1

This register determines if the pins controlled by the General Purpose register (GPREG) are inputs or outputs. Bits 4-0 in GPCNTL correspond to bits 4-0 in the GPREG register. When the bits are enabled as inputs, an internal pull-up is also enabled. If either SCSI function GPCNTL Register has a GPIO pin set as an output, the pin is enabled as an output. If both the SCSI function GPREG registers define a single GPIO pin as an output, the results are indeterminate.

**Bit 7 Master Enable**

The internal bus master signal is presented on GPIO1 if this bit is set, regardless of the state of Bit 1 (GPIO1\_EN).

**Bit 6 Fetch Enable**

The internal op code fetch signal is presented on GPIO0 if this bit is set, regardless of the state of Bit 0 (GPIO0\_EN).

**Bits 5 Reserved**

**Bits 4, 2 GPIO4\_EN-GPIO2\_EN (GPIO Enable)**

General purpose control, corresponding to bit 4 in the GPREG register and the GPIO4 pin. GPIO4 powers-up as a general purpose output, and GPIO3-2 power-up as general purpose inputs.

**Bits 1-0 GPIO1\_EN-GPIO0\_EN (GPIO Enable)**

These bits power-up set, causing the GPIO1 and GPIO0 pins to become inputs. Resetting these bits causes GPIO1-0 to become outputs.

**Register 48h**  
**SCSI Timer Zero (STIME0)**  
*Read/Write*

HTH7	HTH6	HTH5	HRH4	SEL	SEL	SEL	SEL
7	6	5	4	3	2	1	0

Default >>>

0 0 0 0 0 0 0 0

**Bits 7-4 HTH (Handshake-to-Handshake  
Timer Period)**

These bits select the handshake-to-handshake time-out period, the maximum time between SCSI handshakes (SREQ/ to SREQ/ in target mode, or SACK/ to SACK/ in initiator mode). When this timing is exceeded, an interrupt is generated and the HTH bit in the SIST1 register is set. The following table contains time-out periods for the Handshake-to-Handshake Timer, the Selection/Reselection Timer (bits 3-0), and the General Purpose Timer

(STIME1 bits 3-0). For a more detailed explanation of interrupts, refer to Chapter 2, *Functional Description*.

HTH 7-4, SEL 3-0, GEN 3-0	Minimum Time-out (80 MHz Clock) with scale factor bit reset	Minimum Time-out (80 MHz Clock) with scale factor bit set
0000	Disabled	Disabled
0001	100 $\mu$ s	1.6 ms
0010	200 $\mu$ s	3.2 ms
0011	400 $\mu$ s	6.4 ms
0100	800 $\mu$ s	12.8 ms
0101	.6 ms	25.6 ms
0110	3.2 ms	51.2 ms
0111	6.4 ms	102.4 ms
1000	12.8 ms	204.8 ms
1001	25.6 ms	409.6 ms
1010	51.2 ms	819.2 ms
1011	102.4 ms	1.6 sec
1100	204.8 ms	3.2 sec
1101	409.6 ms	6.4 sec
1110	19.2 ms	12.8 sec
1111	1.6+ sec	25.6 sec

*These values are correct if the CCF bits in the SCNTL3 register are set according to the valid combinations in the bit description.*

**Bits 3-0 SEL (Selection Time-Out)**

These bits select the SCSI selection/reselection time-out period. When this timing (plus the 200  $\mu$ s selection abort time) is exceeded, the STO bit in the SIST1 register is set. For a more detailed explanation of interrupts, refer to Chapter 2, *Functional Description*.

**Register 49h**  
**SCSI Timer One (STIME1)**  
*Read/Write*

RES	HTHBA	GENSF	HTHSF	GEN3	GEN2	GEN1	GEN0
7	6	5	4	3	2	1	0
Default >>>							
X	0	0	0	0	0	0	0

**Bit 7 Reserved**

**Bit 6 HTHBA (Handshake-to-Handshake Timer Bus Activity Enable)**

Setting this bit causes this timer to begin testing for SCSI REQ/ACK activity as soon as SBSY/ is asserted, regardless of the agents participating in the transfer.

**Bit 5 GENSF (General Purpose Timer Scale Factor)**

Setting this bit causes this timer to shift by a factor of 16. Refer to the STIME0 register description for details.

**Bit 4 HTHSF (Handshake to Handshake Timer Scale Factor)**

Setting this bit causes this timer to shift by a factor of 16. Refer to the STIME0 register description for details.

**Bits 3-0 GEN3-0 (General Purpose Timer Period)**

These bits select the period of the general purpose timer. The time measured is the time between enabling and disabling of the timer. When this timing is exceeded, the GEN bit in the SIST1 register is set. Refer to the table under STIME0, bits 3-0, for the available time-out periods.

**Note:** To reset a timer before it expires and obtain repeatable delays, the time value must be written to zero first, and then written back to the desired value. This is also required when changing from one time value to another.

**Register 4Ah**  
**Response ID Zero (RESPID0)**  
*Read/Write*

ID	ID	ID	ID	ID	ID	ID	ID
7	6	5	4	3	2	1	0
Default >>>							
X	X	X	X	X	X	X	X

RESPID0 and RESPID1 contain the selection or reselection IDs. In other words, these two 8-bit registers contain the ID that the chip responds to on the SCSI bus. Each bit represents one possible ID with the most significant bit of RESPID1 representing ID 15 and the least significant bit of RESPID0 representing ID 0. The SCID register still contains the chip ID used during arbitration. The chip can respond to more than one ID because more than one bit can be set in the RESPID1 and RESPID0 registers. However, the chip can arbitrate with only one ID value in the SCID register.

### Register 4Bh

#### Response ID One (RESPID1)

*Read/Write*

ID	ID	ID	ID	ID	ID	ID	ID
15	14	13	12	11	10	9	8

Default >>>

X X X X X X X X

RESPID0 and RESPID1 contain the selection or reselection IDs. In other words, these two 8-bit registers contain the ID that the chip responds to on the SCSI bus. Each bit represents one possible ID with the most significant bit of RESPID1 representing ID 15 and the least significant bit of RESPID0 representing ID 0. The SCID register still contains the chip ID used during arbitration. The chip can respond to more than one ID because more than one bit can be set in the RESPID1 and RESPID0 registers. However, the chip can arbitrate with only one ID value in the SCID register.

### Register 4Ch

#### SCSI Test Zero (STEST0)

*Read Only*

SSAID3	SSAID2	SSAID1	SSAID0	SLT	ART	SOZ	SOM
7	6	5	4	3	2	1	0

Default >>>

0 0 0 0 0 X 1 1

#### Bits 7-4 SSAID3-0 (SCSI Selected As ID)

These bits contain the encoded value of the SCSI ID that the SYM53C876 SCSI function is selected or reselected as during a SCSI selection or reselection phase. These bits are read only and contain the encoded value of 0-15 possible IDs that could be used to select the SYM53C876 SCSI function. During a SCSI selection or reselection phase when a valid ID is put on the bus, and the SYM53C876 SCSI function responds to that ID, the “selected as” ID is written into these bits. These bits are used with the RESPID registers to allow response to multiple IDs on the bus.

#### Bit 3 SLT (Selection Response Logic Test)

This bit is set when the SYM53C876 SCSI function is ready to be selected or reselected. This does not take into account the bus settle delay of 400 ns. This bit is used for functional test and fault purposes.

#### Bit 2 ART (Arbitration Priority Encoder Test)

This bit is always set when the SYM53C876 SCSI function exhibits the highest priority ID asserted on the SCSI bus during arbitration. It is primarily used for chip level testing, but it may be used during low level mode operation to determine if the SYM53C876 SCSI function won arbitration.

**Bit 1 SOZ (SCSI Synchronous Offset Zero)**

This bit indicates that the current synchronous SREQ/SACK offset is zero. This bit is not latched and may change at any time. It is used in low level synchronous SCSI operations. When this bit is set, the SYM53C876 SCSI function, as an initiator, is waiting for the target to request data transfers. If the SYM53C876 SCSI function is a target, then the initiator has sent the offset number of acknowledges.

**Bit 0 SOM (SCSI Synchronous Offset Maximum)**

This bit indicates that the current synchronous SREQ/SACK offset is the maximum specified by bits 3-0 in the SCSI Transfer register. This bit is not latched and may change at any time. It is used in low level synchronous SCSI operations. When this bit is set, the SYM53C876 SCSI function, as a target, is waiting for the initiator to acknowledge the data transfers. If the SYM53C876 SCSI function is an initiator, then the target has sent the offset number of requests.

**Register 4Dh**  
**SCSI Test One (STEST1)**  
*Read/Write*

SCLK	ISO	RES	RES	DBLEN	DBLSEL	RES	RES
7	6	5	4	3	2	1	0
Default >>>							
0	0	X	X	0	0	X	X

**Bit 7 SCLK**

When set, this bit disables the external SCLK (SCSI Clock) pin, and the chip uses the PCI clock as the internal SCSI clock. If a transfer rate of 10 Mb/s (or 20 MB/s on a wide SCSI bus) is desired on the SCSI bus, this bit must be reset and at least a 40 MHz external SCLK must be provided.

**Bit 6 ISO\_MODE (SCSI Isolation Mode)**

This bit allows the SYM53C876 SCSI function to put the SCSI bi-directional and input pins into a low power mode when the SCSI bus is not in use. When this bit is set, the SCSI bus inputs are logically isolated from the SCSI bus.

**Bit 5 Reserved**

**Bit 4 Reserved**

**Bit 3 DBLEN (SCLK Doubler Enable)**

This bit, when reset, powers down the internal clock doubler circuit, which doubles the SCLK 40 MHz clock to an internal 80 MHz SCSI clock required for Wide Ultra SCSI operation. Both the SCLK Doubler Enable DBLEN and SCLK Double Select DBLSEL bits must be set in either SCSI function to get the internal 80 MHz SCSI clock.

**Bit 2 DBLSEL (SCLK Doubler Select)**

This bit, when set, selects the output of the internal clock doubler for use as the internal SCSI clock. When reset, this bit selects the clock presented on SCLK for use as the internal SCSI clock.



### Bits 1-0 Reserved

The SYM53C876 SCSI clock doubler doubles a 40 MHz SCSI clock, increasing the frequency to 80 MHz. Follow these steps to use the clock doubler.

1. Set the SCLK Doubler Enable bit (STEST1, bit 3).
2. Wait 20  $\mu$ s.
3. Halt the SCSI clock by setting the Halt SCSI Clock bit (STEST3, bit 5).
4. Set the clock conversion factor using the SCF and CCF fields in the SCNTL3 register.
5. Set the SCLK Doubler Select bit (STEST1, bit 2).
6. Clear the Halt SCSI clock bit.

### Register 4Eh SCSI Test Two (STEST2) *Read/Write*

SCE	ROF	DIF	SLB	SZM	AWS	EXT	LOW
7	6	5	4	3	2	1	0

Default >>>

0 0 0 0 0 0 0 0

#### Bit 7 SCE (SCSI Control Enable)

Setting this bit allows assertion of all SCSI control and data lines through the SOCL and SODL registers regardless of whether the SYM53C876 SCSI function is configured as a target or initiator.

Note: Do not set this bit during normal operation, since it could cause contention on the SCSI bus. It is included for diagnostic purposes only.

#### Bit 6 ROF (Reset SCSI Offset)

Setting this bit clears any outstanding synchronous SREQ/SACK offset. Set this bit, if a SCSI gross error condition occurs, to clear the offset when a synchronous transfer does not complete successfully. The bit automatically clears itself after resetting the synchronous offset.

#### Bit 5 DIF

Setting this bit allows the SYM53C876 SCSI function to interface properly to external differential transceivers. Its only real effect is to tristate the SBSY/, SSEL/, and SRST/ pads for use as pure inputs. Clearing this bit enables single-ended operation. Set this bit in the initialization routine if the differential pair interface is used.

#### Bit 4 SLB (SCSI Loopback Mode)

Setting this bit allows the SYM53C876 SCSI function to perform SCSI loopback diagnostics. That is, it enables the SCSI core to simultaneously perform as both initiator and target.

#### Bit 3 SZM (SCSI High-Impedance Mode)

Setting this bit places all the open-drain 48 mA SCSI drivers into a high-impedance state. This is to allow internal loopback mode operation without affecting the SCSI bus.

**Bit 2 AWS (Always Wide SCSI)**

When this bit is set, all SCSI information transfers are done in 16-bit wide mode. This includes data, message, command, status and reserved phases. Normally, deassert this bit since 16-bit wide message, command, and status phases are not supported by the SCSI specifications.

**Bit 1 EXT (Extend SREQ/SACK Filtering)**

Symbios Logic TolerANT SCSI receiver technology includes a special digital filter on the SREQ/ and SACK/ pins which causes the disregarding of glitches on deasserting edges. Setting this bit increases the filtering period from 30ns to 60ns on the deasserting edge of the SREQ/ and SACK/ signals.

Note: Never set this bit during fast SCSI (greater than 5M transfers per second) operations, because a valid assertion could be treated as a glitch.

**Bit 0 LOW (SCSI Low level Mode)**

Setting this bit places the SYM53C876 SCSI function in low level mode. In this mode, no DMA operations occur, and no SCRIPTS execute. Arbitration and selection may be performed by setting the start sequence bit as described in the SCNTL0 register. SCSI bus transfers are performed by manually asserting and polling SCSI signals. Clearing this bit allows instructions to be executed in SCSI SCRIPTS mode.

Note: It is not necessary to set this bit for access to the SCSI bit-level registers (SODL, SBCL, and input registers).

**Register 4Fh**  
**SCSI Test Three (STEST3)**  
*Read/Write*

TE	STR	HSC	DSI	DIFF	TTM	CSF	STW
7	6	5	4	3	2	1	0
Default >>>							
0	0	0	0	X	0	0	0

**Bit 7 TE (TolerANT Enable)**

Setting this bit enables the active negation portion of Symbios Logic TolerANT technology. Active negation causes the SCSI Request, Acknowledge, Data, and Parity signals to be actively deasserted, instead of relying on external pull-ups, when the SYM53C876 SCSI function is driving these signals. Active deassertion of these signals occurs only when the SYM53C876 SCSI function is in an information transfer phase. When operating in a differential environment or at fast SCSI timings, TolerANT Active negation should be enabled to improve setup and deassertion times. Active negation is disabled after reset or when this bit is cleared. For more information on Symbios Logic TolerANT technology, see Chapter 1.

Note: Set this bit if the Enable Ultra SCSI bit in SCNTL3 is set.

**Bit 6 STR (SCSI FIFO Test Read)**

Setting this bit places the SCSI core into a test mode in which the SCSI FIFO is easily read. Reading the least significant byte of the SODL register causes the FIFO to unload. The functions are summarized in the table below.

Register Name	Register Operation	FIFO Bits	FIFO Function
SODL	Read	15-0	Unload
SODL0	Read	7-0	Unload
SODL1	Read	15-8	None

**Bit 5 HSC (Halt SCSI Clock)**

Asserting this bit causes the internal divided SCSI clock to come to a stop in a glitchless manner. This bit is used for test purposes or to lower  $I_{DD}$  during a power down mode.

**Bit 4 DSI (Disable Single Initiator Response)**

If this bit is set, the SYM53C876 SCSI function ignores all bus-initiated selection attempts that employ the single-initiator option from SCSI-1. In order to select the SYM53C876 SCSI function while this bit is set, the SYM53C876 SCSI function's SCSI ID and the initiator's SCSI ID must both be asserted. Assert this bit in SCSI-2 systems so that a single bit error on the SCSI bus is not interpreted as a single initiator response.

**Bit 3 CHECKHI (Check High Parity)**

If this bit is set, all devices in the SCSI system implementation are assumed to be 16 bits. This causes the SYM53C876 to always check the parity bit for SCSI IDs 15-8 during bus-initiated selection or reselection, assuming parity checking has been enabled. If an 8-bit SCSI device attempts to select the SYM53C876 while this bit is set, the chip ignores the selection attempt, because the parity bit for IDs 15-8 is undriven. See the description of the Enable Parity Checking bit in the SCNTL0 register for more information.

**Bit 2 TTM (Timer Test Mode)**

Asserting this bit facilitates testing of the selection time-out, general purpose, and handshake-to-handshake timers by greatly reducing all three time-out periods. Setting this bit starts all three timers and if the respective bits in the SIEN1 register are asserted, the SYM53C876 SCSI function generates interrupts at time-out. This bit is intended for internal manufacturing diagnosis and should not be used.

**Bit 1 CSF (Clear SCSI FIFO)**

Setting this bit causes the "full flags" for the SCSI FIFO to be cleared. This empties the FIFO. This bit is self-resetting. In addition to the SCSI FIFO pointers, the SIDL, SODL, and SODR full bits in the SSTAT0 and SSTAT2 are cleared.

**Bit 0 STW (SCSI FIFO Test Write)**

Setting this bit places the SCSI core into a test mode in which the FIFO is easily read or written. While this bit is set, writes to the least significant byte of the SODL register cause the entire word contained in this register to be loaded into the FIFO. Writing the least significant byte of the SODL register causes the FIFO to load. These functions are summarized in the table below.

Register Name	Register Operation	FIFO Bits	FIFO Function
SODL	Write	15-0	Load
SODL0	Write	7-0	Load
SODL1	Write	15-8	None

---

**Register 50h-51h**  
**SCSI Input Data Latch (SIDL)**  
*Read Only*

This register is used primarily for diagnostic testing, programmed I/O operation, or error recovery. Data received from the SCSI bus can be read from this register. Data can be written to the SODL register and then read back into the 53C885 by reading this register to allow loopback testing. When receiving SCSI data, the data flows into this register and out to the host FIFO. This register differs from the SBDL register; SIDL contains latched data and the SBDL always contains exactly what is currently on the SCSI data bus. Reading this register causes the SCSI parity bit to be checked, and causes a parity error interrupt if the data is not valid. The power-up values are indeterminate.

---

**Registers 54h-55h**  
**SCSI Output Data Latch (SODL)**  
*Read/Write*

This register is used primarily for diagnostic testing or programmed I/O operation. Data written to this register is asserted onto the SCSI data bus by setting the Assert Data Bus bit in the SCNTL1 register. This register can send data via programmed I/O. Data flows through this register when sending data in any mode. It is also used to write to the synchronous data FIFO when testing the chip. The power-up value of this register is indeterminate.

---

**Registers 58h-59h**  
**SCSI Bus Data Lines (SBDL)**  
*Read Only*

This register contains the SCSI data bus status. Even though the SCSI data bus is active low, these bits are active high. The signal status is not latched and is a true representation of exactly what is on the data bus at the time the register is read. This register is used when receiving data via programmed I/O. This register can also be used for diagnostic testing or in low level mode. The power-up value of this register is indeterminate.

---

**Registers 5Ch-5Fh**  
**Scratch Register B (SCRATCHB)**  
*Read/Write*

This is a general purpose user definable scratch pad register. Apart from CPU access, only Register Read/Write and Memory Moves directed at the SCRATCH register alter its contents. When bit 3 in the CTEST2 register is set, this register contains the base address for the 4 KB internal RAM. Setting CTEST2 bit 3 only causes the base address to appear in the SCRATCHB register; any information previously in the register remains intact. Any writes to this register while the bit is set pass through to the actual SCRATCHB register. The power-up values are indeterminate.

---

**Registers 60h-7Fh**  
**Scratch Registers C-J**  
**(SCRATCHC-SCRATCHJ)**  
*Read/Write*

These registers are general-purpose scratch registers for user-defined functions. They are accessible through Read-Modify-Write functions.

## Chapter 5

# SCSI SCRIPTS Instruction Set

After power up and initialization, the SYM53C876 can operate in the low level register interface mode, or use SCSI SCRIPTS.

With the low level register interface, the user has access to the DMA control logic and the SCSI bus control logic. An external processor has access to the SCSI bus signals and the low level DMA signals, which allows creation of complicated board level test algorithms. The low level interface is useful for backward compatibility with SCSI devices that require certain unique timings or bus sequences to operate properly. Another feature allowed at the low level is loopback testing. In loopback mode, the SCSI core can be directed to talk to the DMA core to test internal data paths all the way out to the chip's pins.

The following sections describe the benefits and use of SCSI SCRIPTS.

---

## SCSI SCRIPTS

To operate in the SCSI SCRIPTS mode, the SYM53C876 requires only a SCRIPTS start address. The start address must be at a dword (four byte) boundary. This aligns all the following SCRIPTS at a dword boundary since all SCRIPTS are 8 or 12 bytes long. Instructions are fetched until an interrupt instruction is encountered, or until an unexpected event (such as a hardware error) causes an interrupt to the external processor.

Once an interrupt is generated, the SYM53C876 halts all operations until the interrupt is serviced. Then, the start address of the next SCRIPTS instruction is written to the DMA SCRIPTS Pointer register to restart the automatic fetching and execution of instructions.

In the SCSI SCRIPTS mode the SYM53C876 is allowed to make decisions based on the status of the SCSI bus, which frees the microprocessor from servicing the numerous interrupts inherent in I/O operations.

Given the rich set of SCSI oriented features included in the instruction set, and the ability to reenter the SCSI algorithm at any point, this high level interface is all that is required for both normal and exception conditions. Switching to low level mode for error recovery is not required.

The following types of SCRIPTS instructions are implemented in the SYM53C876:

- Block Move—used to move data between the SCSI bus and memory
- I/O or Read/Write—causes the SYM53C876 to trigger common SCSI hardware sequences, or to move registers
- Transfer Control—allows SCRIPTS instructions to make decisions based on real time SCSI bus conditions
- Memory Move—causes the SYM53C876 to execute block moves between different parts of main memory
- Load and Store—provides a more efficient way to move data to/from memory from/to an internal register in the chip without using the Memory Move instruction

Each instruction consists of two or three 32-bit words. The first 32-bit word is always loaded into the DCMD and DBC registers, the second into the DSPS register. The third word, used only by Memory Move instructions, is loaded into the TEMP shadow register. In an indirect I/O or

Move instruction, the first two 32-bit op code fetches are followed by one or two more 32-bit fetch cycles.

---

## Sample Operation

The following example describes execution of a SCRIPTS Block Move instruction.

1. The host CPU, through programmed I/O, gives the DMA SCRIPTS Pointer (DSP) register (in the Operating Register file) the starting address in main memory that points to a SCSI SCRIPTS program for execution.
2. Loading the DSP register causes the SYM53C876 to fetch its first instruction at the address just loaded. This fetch is from main memory or the internal RAM, depending on the address.
3. The SYM53C876 typically fetches two dwords (64 bits) and decodes the high order byte of the first dword as a SCRIPTS instruction. If the instruction is a Block Move, the lower three bytes of the first dword are stored and interpreted as the number of bytes to move. The second dword is stored and interpreted as the 32-bit beginning address in main memory to which the move is directed.
4. For a SCSI send operation, the SYM53C876 waits until there is enough space in the DMA FIFO to transfer a programmable size block of data. For a SCSI receive operation, it waits until enough data is collected in the DMA FIFO for transfer to memory. At this point, the SYM53C876 requests use of the PCI bus again to transfer the data.
5. When the SYM53C876 is granted the PCI bus, it executes (as a bus master) a burst transfer (programmable size) of data, decrements the internally stored remaining byte count, increments the address pointer, and then releases the PCI bus. The SYM53C876 stays off the PCI bus until the FIFO can again hold (for a write) or has collected (for a read) enough data to repeat the process.

The process repeats until the internally stored byte count has reached zero. The SYM53C876 releases the PCI bus and then performs another SCRIPTS instruction fetch cycle, using the incremented stored address maintained in the DMA SCRIPTS Pointer register. Execution of SCRIPTS instructions continues until an error condition occurs or an interrupt SCRIPTS instruction is received. At this point, the SYM53C876 interrupts the host CPU and waits for further servicing by the host system. It can execute independent Block Move instructions specifying new byte counts and starting locations in main memory. In this manner, the SYM53C876 performs scatter/gather operations on data without requiring help from the host program, generating a host interrupt, or programming of an external DMA controller.



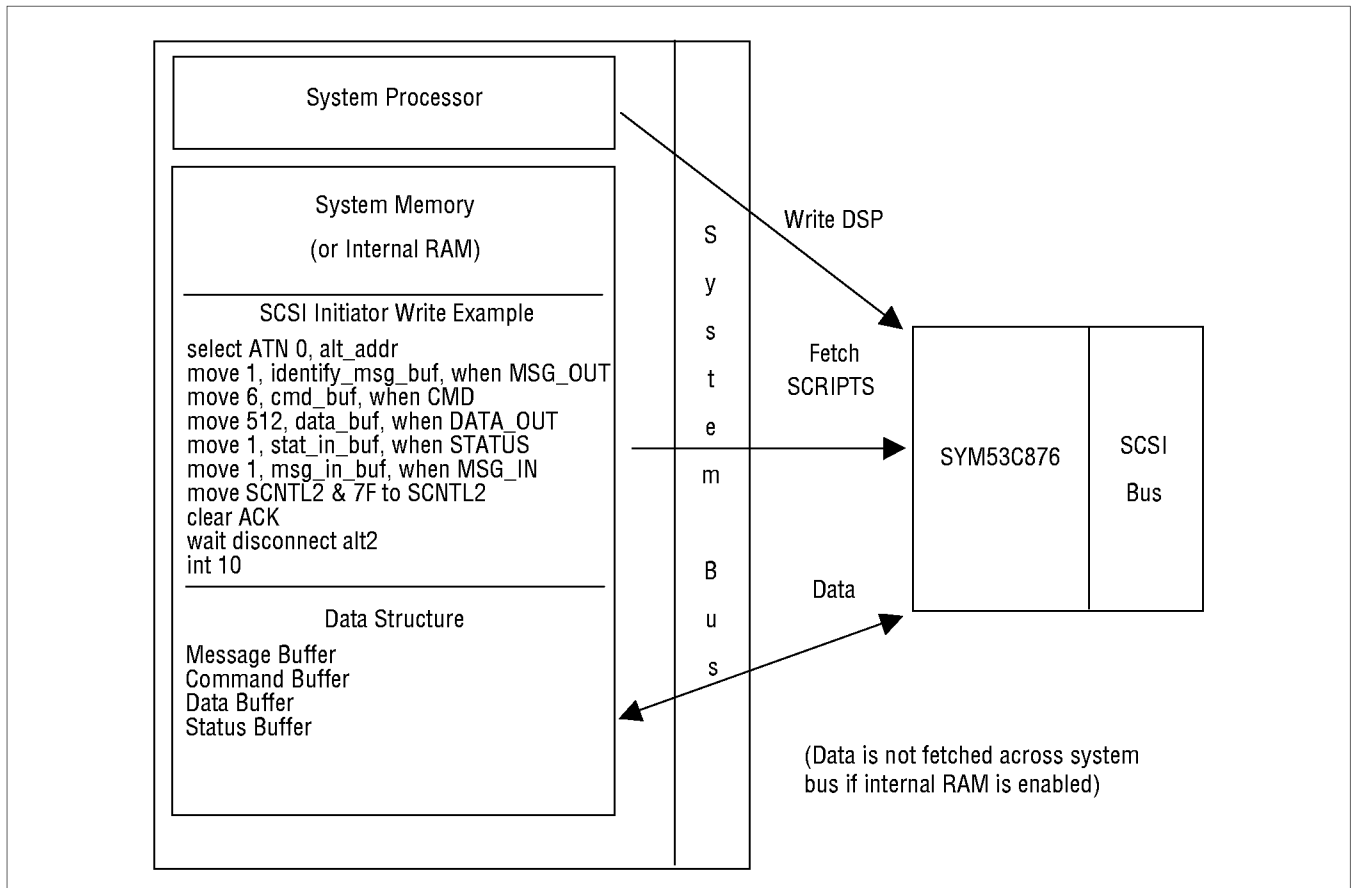

**Figure 5-1: SCRIPTS Overview**

## Block Move Instructions

For Block Move instructions, bits 5 and 4 (SIOM and DIOM) in the DMODE register determine whether the source/destination address resides in memory or I/O space. When data is moved onto the SCSI bus, SIOM controls whether that data comes from I/O or memory space. When data is moved off of the SCSI bus, DIOM controls whether that data goes to I/O or memory space.

### First Dword

**Bits 31-30 Instruction Type-Block Move**

### Bit 29 Indirect Addressing

When this bit is cleared, user data is moved to or from the 32-bit data start address for the Block Move instruction. The value is loaded into the chip's address register and incremented as data is transferred. The address of the data to move is in the second dword of this instruction.

When set, the 32-bit user data start address for the Block Move is the address of a pointer to the actual data buffer address. The value at the 32-bit start address is loaded into the chip's DNAD register via a third longword fetch (4-byte transfer across the host computer bus).

**Direct**

The byte count and absolute address are as follows.

Command	Byte Count
Address of Data	

**Indirect**

Use the fetched byte count, but fetch the data address from the address in the instruction.

Command	Byte Count
Address of Pointer to Data	

Once the data pointer address is loaded, it is executed as when the chip operates in the direct mode. This indirect feature allows specification of a table of data buffer addresses. Using the SCSI SCRIPTS compiler, the table offset is placed in the script at compile time. Then at the actual data transfer time, the offsets are added to the base address of the data address table by the external processor. The logical I/O driver builds a structure of addresses for an I/O rather than treating each address individually.

Note: It is not permitted to use indirect and table indirect addressing simultaneously; use only one addressing method at a time.

**Bit 28 Table Indirect**

When this bit is set, the 24-bit signed value in the start address of the move is treated as a relative displacement from the value in the DSA register. Both the transfer count and the source/destination address are fetched from this address.

Use the signed integer offset in bits 23-0 of the second four bytes of the instruction, added to the value in the DSA register, to fetch first the byte count and then the data address. The signed value is combined with the data structure base address to generate the

physical address used to fetch values from the data structure. Sign-extended values of all ones for negative values are allowed, but bits 31-24 are ignored.

Command	Not Used
Don't Care	Table Offset

Note: It is not permitted to use indirect and table indirect addressing simultaneously; use only one addressing method at a time.

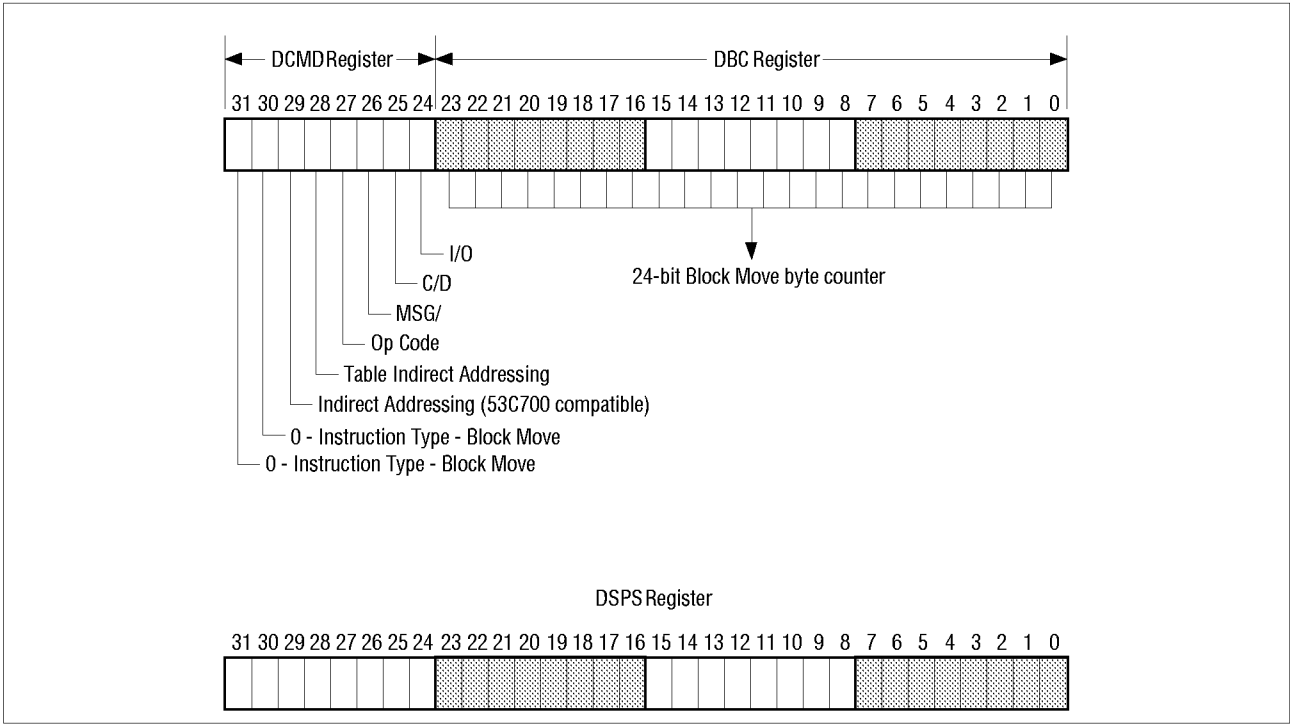

**Figure 5-2: Block Move Instruction Register**

Prior to the start of an I/O, load the Data Structure Base Address register (DSA) with the base address of the I/O data structure. Any address on a long word boundary is allowed.

After a Table Indirect op code is fetched, the DSA is added to the 24-bit signed offset value from the op code to generate the address of the required data; both positive and negative offsets are allowed. A subsequent fetch from that address brings the data values into the chip.

For a MOVE instruction, the 24-bit byte count is fetched from system memory. Then the 32-bit physical address is brought into the SYM53C876. Execution of the move begins at this point.

SCRIPTS can directly execute operating system I/O data structures, saving time at the beginning of an I/O operation. The I/O data structure can begin on any longword boundary and may cross system segment boundaries.

There are two restrictions on the placement of pointer data in system memory: The eight bytes of data in the MOVE instruction must be contiguous, as shown below; and indirect data fetches are not available during execution of a Memory-to-Memory DMA operation.

00	Byte Count
Physical Data Address	

**Bit 27 Op Code**

This 1-bit field defines the instruction to execute as a block move (MOVE).

**Target Mode**

OPC	Instruction Defined
0	MOVE
1	CHMOV

1. The SYM53C876 verifies that it is connected to the SCSI bus as a target before executing this instruction.
2. The SYM53C876 asserts the SCSI phase signals (SMSG/, SC\_D/, and SI\_O/) as defined by the Phase Field bits in the instruction.
3. If the instruction is for the command phase, the SYM53C876 receives the first command byte and decodes its SCSI Group Code.
  - a. If the SCSI Group Code is either Group 0, Group 1, Group 2, or Group 5, then the SYM53C876 overwrites the DBC register with the length of the Command Descriptor Block: 6, 10, or 12 bytes.
  - b. If the Vendor Unique Enhancement 0 (VUE0) bit (SCNTL2, bit 1) is clear and the SCSI group code is a vendor unique code, the SYM53C876 overwrites the DBC register with the length of the Command Descriptor Block: 6, 10, or 12 bytes. If the VUE0 bit is set, the SYM53C876 receives the number of bytes in the byte count regardless of the group code.
  - c. If any other Group Code is received, the DBC register is not modified and the SYM53C876 requests the number of bytes specified in the DBC register. If the DBC register contains 000000h, an illegal instruction interrupt is generated.
4. The SYM53C876 transfers the number of bytes specified in the DBC register starting at the address specified in the DNAD register. If the Op Code bit is set and a data transfer ends on an odd byte boundary, the SYM53C876 stores the last byte in the SCSI Wide Residue Data Register during a receive operation. This

byte is combined with the first byte from the subsequent transfer so that a wide transfer can complete.

5. If the SATN/ signal is asserted by the initiator or a parity error occurred during the transfer, it is possible to halt the transfer and generate an interrupt. The Disable Halt on Parity Error or ATN bit in the SCNTL1 register controls whether the SYM53C876 halts on these conditions immediately, or waits until completion of the current Move.

**Initiator Mode**

OPC	Instruction Defined
0	CHMOV
1	MOVE

1. The SYM53C876 verifies that it is connected to the SCSI bus as an initiator before executing this instruction.
2. The SYM53C876 waits for an unserviced phase to occur. An unserviced phase is defined as any phase (with SREQ/ asserted) for which the SYM53C876 has not yet transferred data by responding with a SACK/.
3. The SYM53C876 compares the SCSI phase bits in the DCMD register with the latched SCSI phase lines stored in the SSTAT1 register. These phase lines are latched when SREQ/ is asserted.
4. If the SCSI phase bits match the value stored in the SSTAT1 register, the SYM53C876 transfers the number of bytes specified in the DBC register starting at the address pointed to by the DNAD register. If the op code bit is cleared and a data transfer ends on an odd byte boundary, the SYM53C876 stores the last byte in the SCSI Wide Residue Data Register during a receive operation, or in the SCSI Output Data Latch Register during a send operation. This byte is combined with the first byte from the subsequent transfer so that a wide transfer can complete.

5. If the SCSI phase bits do not match the value stored in the SSTAT1 register, the SYM53C876 generates a phase mismatch interrupt and the instruction is not executed.
6. During a Message-Out phase, after the SYM53C876 has performed a select with Attention (or SATN/ is manually asserted with a Set ATN instruction), the SYM53C876 deasserts SATN/ during the final SREQ/SACK handshake.
7. When the SYM53C876 is performing a block move for Message-In phase, it does not deassert the SACK/ signal for the last SREQ/SACK handshake. Clear the SACK signal using the Clear SACK I/O instruction.

#### Bits 26-24 SCSI Phase

This 3-bit field defines the desired SCSI information transfer phase. When the SYM53C876 operates in initiator mode, these bits are compared with the latched SCSI phase bits in the SSTAT1 register. When the SYM53C876 operates in target mode, it asserts the phase defined in this field. The following table describes the possible combinations and the corresponding SCSI phase.

MSG	C/D	I/O	SCSI Phase
0	0	0	Data-Out
0	0	1	Data-In
0	1	0	Command
0	1	1	Status
1	0	0	Reserved-Out
1	0	1	Reserved-In
1	1	0	Message-Out
1	1	1	Message-In

#### Bits 23-0 Transfer Counter

This 24-bit field specifies the number of data bytes to move between the SYM53C876 and system memory. The field is stored in the DBC register. When the SYM53C876 transfers data to/from memory, the DBC register is decremented by the number of bytes transferred. In addition, the DNAD register is incremented by the number of bytes transferred. This process is repeated until the DBC register is decremented to zero. At this time, the SYM53C876 fetches the next instruction.

If bit 28 is set, indicating table indirect addressing, this field is not used. The byte count is instead fetched from a table pointed to by the DSA register.

---

### Second Dword

#### Bits 31-0 Start Address

This 32-bit field specifies the starting address of the data to move to/from memory. This field is copied to the DNAD register. When the SYM53C876 transfers data to or from memory, the DNAD register is incremented by the number of bytes transferred.

When bit 29 is set, indicating indirect addressing, this address is a pointer to an address in memory that points to the data location. When bit 28 is set, indicating table indirect addressing, the value in this field is an offset into a table pointed to by the DSA. The table entry contains byte count and address information.

---

## I/O Instructions

---

### First Dword

#### Bits 31-30 Instruction Type - I/O Instruction

#### Bits 29-27 Op Code

The following Op Code bits have different meanings, depending on whether the

SYM53C876 is operating in initiator or target mode. Op Code selections 101-111 are considered Read/Write instructions, and are described in that section.

### Target Mode

OPC2	OPC1	OPC0	Instruction Defined
0	0	0	Reselect
0	0	1	Disconnect
0	1	0	Wait Select
0	1	1	Set
1	0	0	Clear

#### Reselect Instruction

1. The SYM53C876 arbitrates for the SCSI bus by asserting the SCSI ID stored in the SCID register. If it loses arbitration, it tries again during the next available arbitration cycle without reporting any lost arbitration status.
2. If the SYM53C876 wins arbitration, it attempts to reselect the SCSI device whose ID is defined in the destination ID field of the instruction. Once the SYM53C876 wins arbitration, it fetches the next instruction from the address pointed to by the DSP register. This way the SCRIPTS can move on to the next instruction before the reselection completes. It continues executing SCRIPTS until a SCRIPT that requires a response from the initiator is encountered.
3. If the SYM53C876 is selected or reselected before winning arbitration, it fetches the next instruction from the address pointed to by the 32-bit jump address field stored in the DNAD register. Manually set the SYM53C876 to initiator mode if it is reselected, or to target mode if it is selected.

#### Disconnect Instruction

The SYM53C876 disconnects from the SCSI bus by deasserting all SCSI signal outputs.

#### Wait Select Instruction

1. If the SYM53C876 is selected, it fetches the next instruction from the address pointed to by the DSP register.
2. If reselected, the SYM53C876 fetches the next instruction from the address pointed to by the 32-bit jump address field stored in the DNAD register. Manually set the SYM53C876 to initiator mode when it is reselected.
3. If the CPU sets the SIGP bit in the ISTAT register, the SYM53C876 aborts the Wait Select instruction and fetches the next instruction from the address pointed to by the 32-bit jump address field stored in the DNAD register.

#### Set Instruction

When the SACK/ or SATN/ bits are set, the corresponding bits in the SOCL register are set. Do not set SACK/ or SATN/ except for testing purposes. When the target bit is set, the corresponding bit in the SCNTL0 register is also set. When the carry bit is set, the corresponding bit in the Arithmetic Logic Unit (ALU) is set.

Note: None of the signals are set on the SCSI bus in target mode.

#### Clear Instruction

When the SACK/ or SATN/ bits are set, the corresponding bits are cleared in the SOCL register. Do not set SACK/ or SATN/ except for testing purposes. When the target bit is set, the corresponding bit in the SCNTL0 register is cleared. When the carry bit is set, the corresponding bit in the ALU is cleared.

Note: None of the signals are reset on the SCSI bus in target mode.

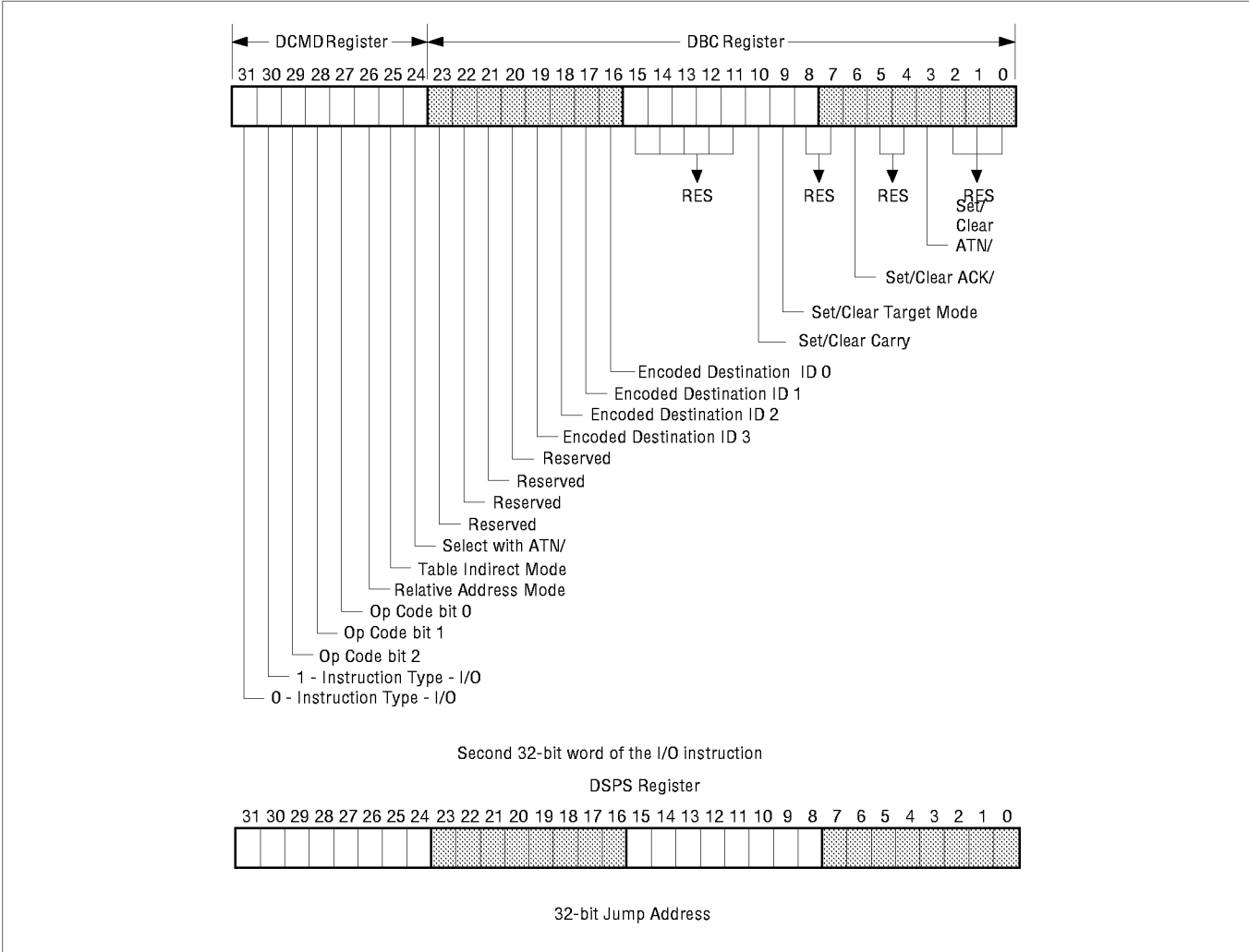

**Figure 5-3: I/O Instruction Register**

**Initiator Mode**

OPC2	OPC1	OPC0	Instruction Defined
0	0	0	Select
0	0	1	Wait Disconnect
0	1	0	Wait Reselect
0	1	1	Set
1	0	0	Clear

*Select Instruction*

1. The SYM53C876 arbitrates for the SCSI bus

by asserting the SCSI ID stored in the SCID register. If it loses arbitration, it tries again during the next available arbitration cycle without reporting any lost arbitration status.

2. If the SYM53C876 wins arbitration, it attempts to select the SCSI device whose ID is defined in the destination ID field of the instruction. Once the SYM53C876 wins arbitration, it fetches the next instruction from the address pointed to by the DSP register. This way the SCRIPTS can move to the next instruction before the selection completes. It continues executing SCRIPTS until a SCRIPT

that requires a response from the target is encountered.

3. If the SYM53C876 is selected or reselected before winning arbitration, it fetches the next instruction from the address pointed to by the 32-bit jump address field stored in the DNAD register. Manually set the SYM53C876 to initiator mode if it is reselected, or to target mode if it is selected.
4. If the Select with SATN/ field is set, the SATN/ signal is asserted during the selection phase.

#### *Wait Disconnect Instruction*

The SYM53C876 waits for the target to perform a “legal” disconnect from the SCSI bus. A “legal” disconnect occurs when SBSY/ and SSEL/ are inactive for a minimum of one Bus Free delay (400 ns), after the SYM53C876 receives a Disconnect Message or a Command Complete Message.

#### *Wait Reselect Instruction*

1. If the SYM53C876 is selected before being reselected, it fetches the next instruction from the address pointed to by the 32-bit jump address field stored in the DNAD register. Manually set the SYM53C876 to target mode when it is selected.
2. If the SYM53C876 is reselected, it fetches the next instruction from the address pointed to by the DSP register.
3. If the CPU sets the SIGP bit in the ISTAT register, the SYM53C876 aborts the Wait Reselect instruction and fetches the next instruction from the address pointed to by the 32-bit jump address field stored in the DNAD register.

#### *Set Instruction*

When the SACK/ or SATN/ bits are set, the corresponding bits in the SOCL register are set. When the target bit is set, the corresponding bit in the SCNTL0 register is also set. When the carry bit is set, the corresponding bit in the ALU is set.

#### *Clear Instruction*

When the SACK/or SATN/ bits are set, the corresponding bits are cleared in the SOCL register. When the target bit is set, the corresponding bit in the SCNTL0 register is cleared. When the carry bit is set, the corresponding bit in the ALU is cleared.

#### **Bit 26 Relative Addressing Mode**

When this bit is set, the 24-bit signed value in the DNAD register is used as a relative displacement from the current DSP address. Use this bit only in conjunction with the Select, Reselect, Wait Select, and Wait Reselect instructions. The Select and Reselect instructions can contain an absolute alternate jump address or a relative transfer address.

#### **Bit 25 Table Indirect Mode**

When this bit is set, the 24-bit signed value in the DBC register is added to the value in the DSA register, used as an offset relative to the value in the Data Structure Base Address (DSA) register. The SCNTL3 value, SCSI ID, synchronous offset and synchronous period are loaded from this address. Prior to the start of an I/O, load the DSA with the base address of the I/O data structure. Any address on a longword boundary is allowed. After a Table Indirect op code is fetched, the DSA is added to the 24-bit signed offset value from the op code to generate the address of the required data. Both positive and negative offsets are allowed. A subsequent fetch from that address brings the data values into the chip.

SCRIPTS can directly execute operating system I/O data structures, saving time at the beginning of an I/O operation. The I/O data structure can begin on any dword boundary and may cross system segment boundaries. There are two restrictions on the placement of data in system memory:

1. The I/O data structure must lie within the 8 MB above or below the base address.



2. An I/O command structure must have all four bytes contiguous in system memory, as shown below. The offset/period bits are ordered as in the SXFER register. The configuration bits are ordered as in the SCNTL3 register.

Config	ID	Offset/ period	(00)
--------	----	-------------------	------

Use this bit only in conjunction with the Select, Reselect, Wait Select, and Wait Reselect instructions. It is allowable to set bits 25 and 26 individually or in combination:

	Bit 25	Bit 26
Direct	0	0
Table Indirect	0	1
Relative	1	0
Table Relative	1	1

**Direct**

Uses the device ID and physical address in the instruction.

Command	ID	Not Used	Not Used
Absolute Alternate Address			

**Table Indirect**

Uses the physical jump address, but fetches data using the table indirect method.

Command	Table Offset
Absolute Alternate Address	

**Relative**

Uses the device ID in the instruction, but treats the alternate address as a relative jump.

Command	ID	Not Used	Not Used
Alternate Jump Offset			

**Table Relative**

Treats the alternate jump address as a relative jump and fetches the device ID, synchronous offset, and synchronous period indirectly. Adds the value in bits 23-0 of the first four bytes of the SCRIPTS instruction to the data structure base address to form the fetch address.

Command	Table Offset
Alternate Jump Offset	

**Bit 24 Select with ATN/**

This bit specifies whether SATN/ is asserted during the selection phase when the SYM53C876 is executing a Select instruction. When operating in initiator mode, set this bit for the Select instruction. If this bit is set on any other I/O instruction, an illegal instruction interrupt is generated.

**Bit 23-20 Reserved**

**Bits 19-16 Encoded SCSI Destination ID**

This 4-bit field specifies the destination SCSI ID for an I/O instruction.

**Bits 15-11 Reserved**

**Bit 10 Set/Clear Carry**

This bit is used in conjunction with a Set or Clear instruction to set or clear the Carry bit. Setting this bit with a Set instruction asserts the Carry bit in the ALU. Setting this bit with a Clear instruction deasserts the Carry bit in the ALU.

**Bit 9 Set/Clear Target Mode**

This bit is used in conjunction with a Set or

Clear instruction to set or clear target mode. Setting this bit with a Set instruction configures the SYM53C876 as a target device (this sets bit 0 of the SCNTL0 register). Setting this bit with a Clear instruction configures the SYM53C876 as an initiator device (this clears bit 0 of the SCNTL0 register).

**Bits 8-7 Reserved**

**Bit 6 Set/Clear SACK/**

**Bits 5-4 Reserved**

**Bit 3 Set/Clear SATN/**

These two bits are used in conjunction with a Set or Clear instruction to assert or deassert the corresponding SCSI control signal. Bit 6 controls the SCSI SACK/ signal. Bit 3 controls the SCSI SATN/ signal.

Setting either of these bits sets or resets the corresponding bit in the SOCL register, depending on the instruction used. The Set instruction is used to assert SACK/ and/or SATN/ on the SCSI bus. The Clear instruction is used to deassert SACK/ and/or SATN/ on the SCSI bus.

Since SACK/ and SATN/ are initiator signals, they are not asserted on the SCSI bus unless the SYM53C876 is operating as an initiator or the SCSI Loopback Enable bit is set in the STTEST2 register.

The Set/Clear SCSI ACK/ATN instruction is used after message phase Block Move operations to give the initiator the opportunity to assert attention before acknowledging the last message byte. For example, if the initiator wishes to reject a message, it issues an Assert SCSI ATN instruction before a Clear SCSI ACK instruction.

**Bits 2-0 Reserved**

---

**Second Dword**

**Bits 31-0 Start Address**

This 32-bit field contains the memory address

to fetch the next instruction if the selection or reselection fails.

If relative or table relative addressing is used, this value is a 24-bit signed offset relative to the current DSP register value.

---

## Read/Write Instructions

The Read/Write instruction supports addition, subtraction, and comparison of two separate values within the chip. It performs the desired operation on the specified register and the SFBR register, then stores the result back to the specified register or the SFBR. If the COM bit (DCNTL, bit 0) is cleared, Read/Write instruction can not be used.

---

### First Dword

**Bits 31-30 Instruction Type - Read/Write Instruction**

The Read/Write instruction uses operator bits 26 through 24 in conjunction with the opcode bits to determine which instruction is currently selected.

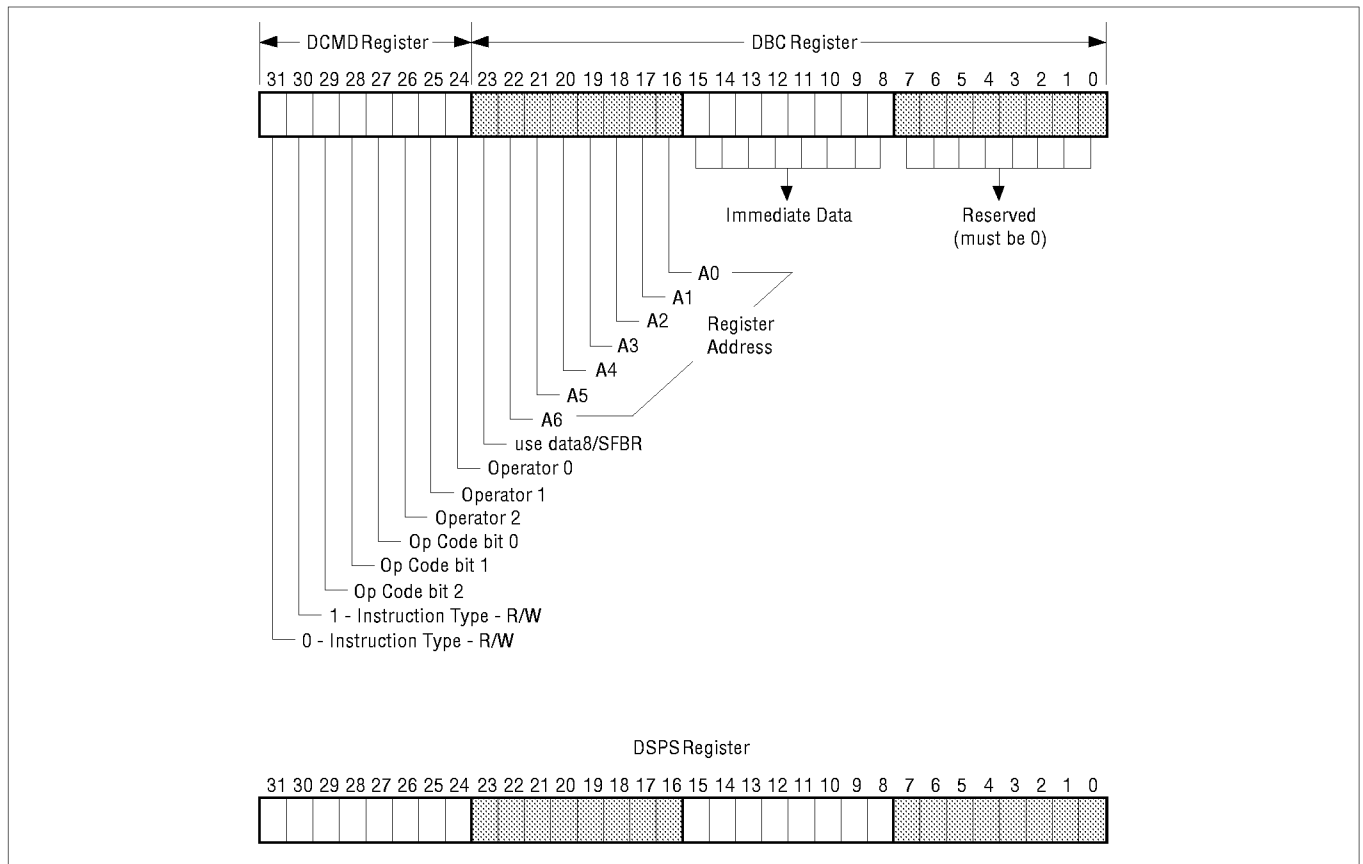

**Figure 5-4: Read/Write Instruction Register**

**Bits 29-27 Op Code**

The combinations of these bits determine if the instruction is a Read/Write or an I/O instruction. Op codes 000 through 100 are considered I/O instructions.

**Bits 26-24 Operator**

These bits are used in conjunction with the op code bits to determine which instruction is currently selected. Refer to table 6-1 for field definitions.

**Bit 23 Use data 8/SFBR**

When this bit is set, SFBR is used instead of the data8 value during a Read-Modify-Write instruction (see Table 5-1). This allows the user to add two register values.

**Bits 22-16 Register Address - A(6-0)**

It is possible to change register values from SCRIPTS in read-modify-write cycles or move to/from SFBR cycles. A(6-0) selects an 8-bit source/destination register within the SYM53C876.

**Bits 15-8 Immediate Data**

This 8-bit value is used as a second operand in logical and arithmetic functions.

**Bits 7-0 Reserved**

---

## Second Dword

### Bits 31-0 Destination Address

This field contains the 32-bit destination address where the data is to move.

---

## Read-Modify-Write Cycles

During these cycles the register is read, the selected operation is performed, and the result is written back to the source register.

The Add operation is used to increment or decrement register values (or memory values if used in conjunction with a Memory-to-Register Move operation) for use as loop counters.

Subtraction is not available when SFBR is used instead of data8 in the instruction syntax. To subtract one value from another when using SFBR, first XOR the value to subtract (subtrahend) with 0xFF, and add 1 to the resulting value. This creates the 2's compliment of the subtrahend. The two values are then added to obtain the difference.

---

## Move to/from SFBR Cycles

All operations are read-modify-writes. However, two registers are involved, one of which is always the SFBR. The possible functions of this instruction are:

- Write one byte (value contained within the SCRIPTS instruction) into any chip register.
- Move to/from the SFBR from/to any other register.
- Alter the value of a register with AND/OR/ADD/XOR/SHIFT LEFT/SHIFT RIGHT operators.
- After moving values to the SFBR, the compare and jump, call, or similar instructions are used to check the value.
- A Move-to-SFBR followed by a Move-from-SFBR is used to perform a register to register move.

**Table 5-1: Read/Write Instructions**

<b>Operator</b>	<b>Op Code 111 Read Modify Write</b>	<b>Op Code 110 Move to SFBR</b>	<b>Op Code 101 Move from SFBR</b>
000	Move data into register. Syntax: “Move data8 to RegA”	Move data into SFBR register. Syntax: “Move data8 to SFBR”	Move data into register. Syntax: “Move data8 to RegA”
001*	Shift register one bit to the left and place the result in the same register. Syntax: “Move RegA SHL RegA”	Shift register one bit to the left and place the result in the SFBR register. Syntax: “Move RegA SHL SFBR”	Shift the SFBR register one bit to the left and place the result in the register. Syntax: “Move SFBR SHL RegA”
010	OR data with register and place the result in the same register. Syntax: “Move RegA   data8 to RegA”	OR data with register and place the result in the SFBR register. Syntax: “Move RegA   data8 to SFBR”	OR data with SFBR and place the result in the register. Syntax: “Move SFBR   data8 to RegA”
011	XOR data with register and place the result in the same register. Syntax: “Move RegA XOR data8 to RegA”	XOR data with register and place the result in the SFBR register. Syntax: “Move RegA XOR data8 to SFBR”	XOR data with SFBR and place the result in the register. Syntax: “Move SFBR XOR data8 to RegA”
100	AND data with register and place the result in the same register. Syntax: “Move RegA & data8 to RegA”	AND data with register and place the result in the SFBR register. Syntax: “Move RegA & data8 to SFBR”	AND data with SFBR and place the result in the register. Syntax: “Move SFBR & data8 to RegA”
101*	Shift register one bit to the right and place the result in the same register. Syntax: “Move RegA SHR RegA”	Shift register one bit to the right and place the result in the SFBR register. Syntax: “Move RegA SHR SFBR”	Shift the SFBR register one bit to the right and place the result in the register. Syntax: “Move SFBR SHR RegA”
110	Add data to register without carry and place the result in the same register. Syntax: “Move RegA + data8 to RegA”	Add data to register without carry and place the result in the SFBR register. Syntax: “Move RegA + data8 to SFBR”	Add data to SFBR without carry and place the result in the register. Syntax: “Move SFBR + data8 to RegA”
111	Add data to register with carry and place the result in the same register. Syntax: “Move RegA + data8 to RegA with carry”	Add data to register with carry and place the result in the SFBR register. Syntax: “Move RegA + data8 to SFBR with carry”	Add data to SFBR with carry and place the result in the register. Syntax: “Move SFBR + data8 to RegA with carry”

*Notes:*

1. Substitute the desired register name or address for “RegA” in the syntax examples
2. data8 indicates eight bits of data
3. Use SFBR instead of data8 to add two register values.

\* Data is shifted through the Carry bit and the Carry bit is shifted into the data byte

# Transfer Control Instructions

## First Dword

### Bits 31-30 Instruction Type - Transfer Control Instruction

### Bits 29-27 Op Code

This 3-bit field specifies the type of transfer control instruction to execute. All transfer control instructions can be conditional. They can be dependent on a true/false comparison of the ALU Carry bit or a comparison of the SCSI information transfer phase with the Phase field, and/or a comparison of the First Byte Received with the Data Compare field. Each instruction can operate in initiator or target mode.

## Call Instruction

1. The SYM53C876 can do a true/false comparison of the ALU carry bit, or compare the phase and/or data as defined by the Phase Compare, Data Compare, and True/False bit fields. If the comparisons are true, it loads the DSP register with the contents of the DSPS register and that address value becomes the address of the next instruction.

When the SYM53C876 executes a Call instruction, the instruction pointer contained in the DSP register is stored in the TEMP register. Since the TEMP register is not a stack and can only hold one dword, nested call instructions are not allowed.

2. If the comparisons are false, the SYM53C876 fetches the next instruction from the address pointed to by the DSP register and the instruction pointer is not modified.

OPC2	OPC1	OPC0	Instruction Defined
0	0	0	Jump
0	0	1	Call
0	1	0	Return
0	1	1	Interrupt
1	X	X	Reserved

## Jump Instruction

1. The SYM53C876 can do a true/false comparison of the ALU carry bit, or compare the phase and/or data as defined by the Phase Compare, Data Compare and True/False bit fields. If the comparisons are true, the it loads the DSP register with the contents of the DSPS register. The DSP register now contains the address of the next instruction.
2. If the comparisons are false, the SYM53C876 fetches the next instruction from the address pointed to by the DSP register, leaving the instruction pointer unchanged.

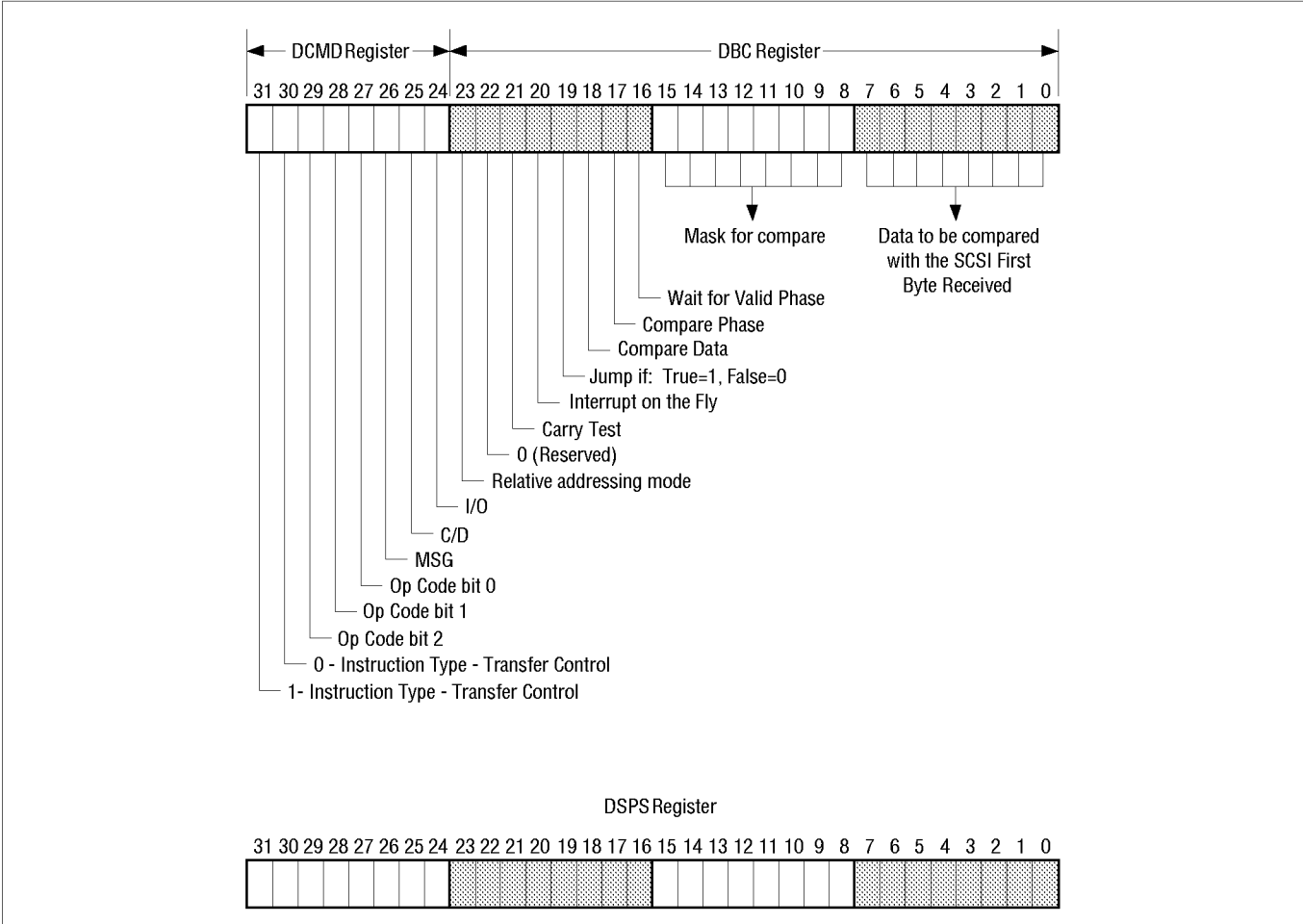

**Figure 5-5: Transfer Control Instruction**

**Return Instruction**

1. The SYM53C876 can do a true/false comparison of the ALU carry bit, or compare the phase and/or data as defined by the Phase Compare, Data Compare, and True/False bit fields. If the comparisons are true, it loads the DSP register with the contents of the DSPS register. That address value becomes the address of the next instruction.

When a Return instruction is executed, the value stored in the TEMP register is returned to the DSP register. The SYM53C876 does not check to see whether the Call instruction has already been executed. It does not generate

an interrupt if a Return instruction is executed without previously executing a Call instruction.

2. If the comparisons are false, the SYM53C876 fetches the next instruction from the address pointed to by the DSP register and the instruction pointer is not modified.

**Interrupt Instructions**

*Interrupt*

- a. The SYM53C876 can do a true/false comparison of the ALU carry bit, or compare the phase and/or data as defined by the Phase Compare, Data Compare, and True/False bit fields. If the

comparisons are true, the SYM53C876 generates an interrupt by asserting the IRQ/ signal.



- b. The 32-bit address field stored in the DSPS register (not DNAD as in 53C700) can contain a unique interrupt service vector. When servicing the interrupt, this unique status code allows the ISR to quickly identify the point at which the interrupt occurred.
- c. The SYM53C876 halts and the DSP register must be written to start any further operation.

*Interrupt on-the-Fly*

- a. The SYM53C876 can do a true/false comparison of the ALU carry bit or compare the phase and/or data as defined by the Phase Compare, Data Compare, and True/False bit fields. If the comparisons are true, and the Interrupt on the Fly bit (ISTAT bit 2) is set, the SYM53C876 asserts the Interrupt on the Fly bit.

**Bits 26-24 SCSI Phase**

This 3-bit field corresponds to the three SCSI bus phase signals which are compared with the phase lines latched when SREQ/ is asserted. Comparisons can be performed to determine the SCSI phase actually being driven on the SCSI bus. The following table describes the possible combinations and their corresponding SCSI phase. These bits are only valid when the SYM53C876 is operating in initiator mode. Clear these bits when the SYM53C876 is operating in the target mode.

MSG	C/D	I/O	SCSI Phase
0	0	0	Data-Out
0	0	1	Data-In
0	1	0	Command
0	1	1	Status
1	0	0	Reserved-Out
1	0	1	Reserved-In
1	1	0	Message-Out
1	1	1	Message-In

**Bit 23 Relative Addressing Mode**

When this bit is set, the 24-bit signed value in the DSPS register is used as a relative offset from the current DSP address (which is pointing to the next instruction, not the one currently executing). Relative mode does not apply to Return and Interrupt SCRIPTS.

**Jump/Call an Absolute Address**

Start execution at the new absolute address.

Command	Condition Codes
Absolute Alternate Address	

**Jump/Call a Relative Address**

Start execution at the current address plus (or minus) the relative offset.

Command	Condition Codes
Don't Care	Alternate Jump Offset

The SCRIPTS program counter is a 32-bit value pointing to the SCRIPT currently under execution by the SYM53C876. The next address is formed by adding the 32-bit program counter to the 24-bit signed value of the last 24 bits of the Jump or Call instruction. Because it is signed (twos compliment), the jump can be forward or backward.

A relative transfer can be to any address within a 16-MB segment. The program counter is combined with the 24-bit signed offset (using addition or subtraction) to form the new execution address.

SCRIPTS programs may contain a mixture of direct jumps and relative jumps to provide maximum versatility when writing SCRIPTS. For example, major sections of code can be accessed with far calls using the 32-bit physical address, then local labels can be called using relative transfers. If a SCRIPT is written using only relative transfers it does not require any run time alteration of physical addresses, and can be stored in and executed from a PROM.

**Bit 21 Carry Test**

When this bit is set, decisions based on the ALU carry bit can be made. True/False comparisons are legal, but Data Compare and Phase Compare are illegal.

**Bit 20 Interrupt on the Fly**

When this bit is set, the interrupt instruction does not halt the SCRIPTS processor. Once the interrupt occurs, the Interrupt on the Fly bit (ISTAT bit 2) is asserted.

**Bit 19 Jump If True/False**

This bit determines whether the SYM53C876 branches when a comparison is true or when a comparison is false. This bit applies to phase compares, data compares, and carry tests. If both the Phase Compare and Data Compare bits are set, then both compares must be true to branch on a true condition. Both compares must be false to branch on a false condition.

Bit 19	Result of Compare	Action
0	False	Jump Taken
0	True	No Jump
1	False	No Jump
1	True	Jump Taken

**Bit 18 Compare Data**

When this bit is set, the first byte received from the SCSI data bus (contained in SFBR register) is compared with the Data to be Compared Field in the Transfer Control instruction. The Wait for Valid Phase bit controls when this compare occurs. The Jump if True/False bit determines the condition (true or false) to branch on.

**Bit 17 Compare Phase**

When the SYM53C876 is in initiator mode, this bit controls phase compare operations. When this bit is set, the SCSI phase signals (latched by SREQ/) are compared to the Phase Field in the Transfer Control instruction. If they match, the comparison is true. The Wait for Valid Phase bit controls when the compare occurs. When the SYM53C876 is operating in target mode this bit, when set,

tests for an active SCSI SATN/ signal.

#### Bit 16 Wait For Valid Phase

If the Wait for Valid Phase bit is set, the SYM53C876 waits for a previously unserved phase before comparing the SCSI phase and data.

If the Wait for Valid Phase bit is clear, the SYM53C876 compares the SCSI phase and data immediately.

#### Bits 15-8 Data Compare Mask

The Data Compare Mask allows a SCRIPT to test certain bits within a data byte. During the data compare, if any mask bits are set the corresponding bit in the SFBR data byte is ignored. For instance, a mask of 01111111b and data compare value of 1XXXXXXXXb allows the SCRIPTS processor to determine whether or not the high order bit is set while ignoring the remaining bits.

#### Bits 7-0 Data Compare Value

This 8-bit field is the data compared against the SCSI First Byte Received (SFBR) register. These bits are used in conjunction with the Data Compare Mask Field to test for a particular data value. If the COM bit (DCNTL, bit 0) is cleared, the value in the SFBR register may not be stable. In this case, do not use instructions using this data compare value.

---

## Second Dword

#### Bits 31-0 Jump Address

This 32-bit field contains the address of the next instruction to fetch when a jump is taken. Once the SYM53C876 fetches the instruction from the address pointed to by these 32 bits, this address is incremented by 4, loaded into the DSP register and becomes the current instruction pointer.

---

## Memory Move Instructions

For Memory Move instructions, bits 5 and 4 (SIOM and DIOM) in the DMODE register determine whether the source or destination addresses reside in memory or I/O space. By setting these bits appropriately, data may be moved within memory space, within I/O space, or between the two address spaces.

The Memory Move instruction is used to copy the specified number of bytes from the source address to the destination address.

Allowing the SYM53C876 to perform memory moves frees the system processor for other tasks and moves data at higher speeds than available from current DMA controllers. Up to 16 MB may be transferred with one instruction. There are two restrictions:

1. Both the source and destination addresses must start with the same address alignment (A(1-0) must be the same). If source and destination are not aligned, then an illegal instruction interrupt occurs. For the PCI Cache Line Size register setting to take effect, the source and destination must be the same distance from a cache line boundary.
2. Indirect addresses are not allowed. A burst of data is fetched from the source address, put into the DMA FIFO and then written out to the destination address. The move continues until the byte count decrements to zero, then another SCRIPT is fetched from system memory.

The DSPS and DSA registers are additional holding registers used during the Memory Move; however, the contents of the DSA register are preserved.

#### Bits 31-39 Instruction Type—Memory Move

#### Bits 28-25 Reserved

These bits are reserved and must be zero. If any of these bits is set, an illegal instruction interrupt occurs.

**Bit 24 No Flush**

**Note:** This bit has no effect unless the Pre-fetch Enable bit in the DCNTL register is set. For information on SCRIPTS instruction prefetching, see Chapter 2.

When this bit is set, the SYM53C876 performs a Memory Move without flushing the prefetch unit. When this bit is clear, the Memory Move instruction automatically flushes the prefetch unit. Use the No Flush option if the source and destination are not within four instructions of the current Memory Move instruction.

**Bits 23-0 Transfer Count**

The number of bytes to transfer is stored in the lower 24 bits of the first instruction word.

---

**Read/Write System Memory from a Script**

By using the Memory Move instruction, single or multiple register values are transferred to or from system memory.

Because the SYM53C876 responds to addresses as defined in the Base I/O or Base Memory registers, it can be accessed during a Memory Move operation if the source or destination address decodes to within the chip's register space. If this occurs, the register indicated by the lower seven bits of the address is taken as the data source or destination. In this way, register values are saved to system memory and later restored, and SCRIPTS can make decisions based on data values in system memory.

The SFBR is not writable via the CPU, and therefore not by a Memory Move. However, it can be loaded via SCRIPTS Read/Write operations. To load the SFBR with a byte stored in system memory, first move the byte to an intermediate SYM53C876 register (for example, a SCRATCH register), and then to the SFBR.

The same address alignment restrictions apply to register access operations as to normal memory-to-memory transfers.

---

**Second Dword**

**Bits 31-0 DSPS Register**

These bits contain the source address of the Memory Move.

---

**Third Dword**

**Bits 31-0 TEMP Register**

These bits contain the destination address for the Memory Move.

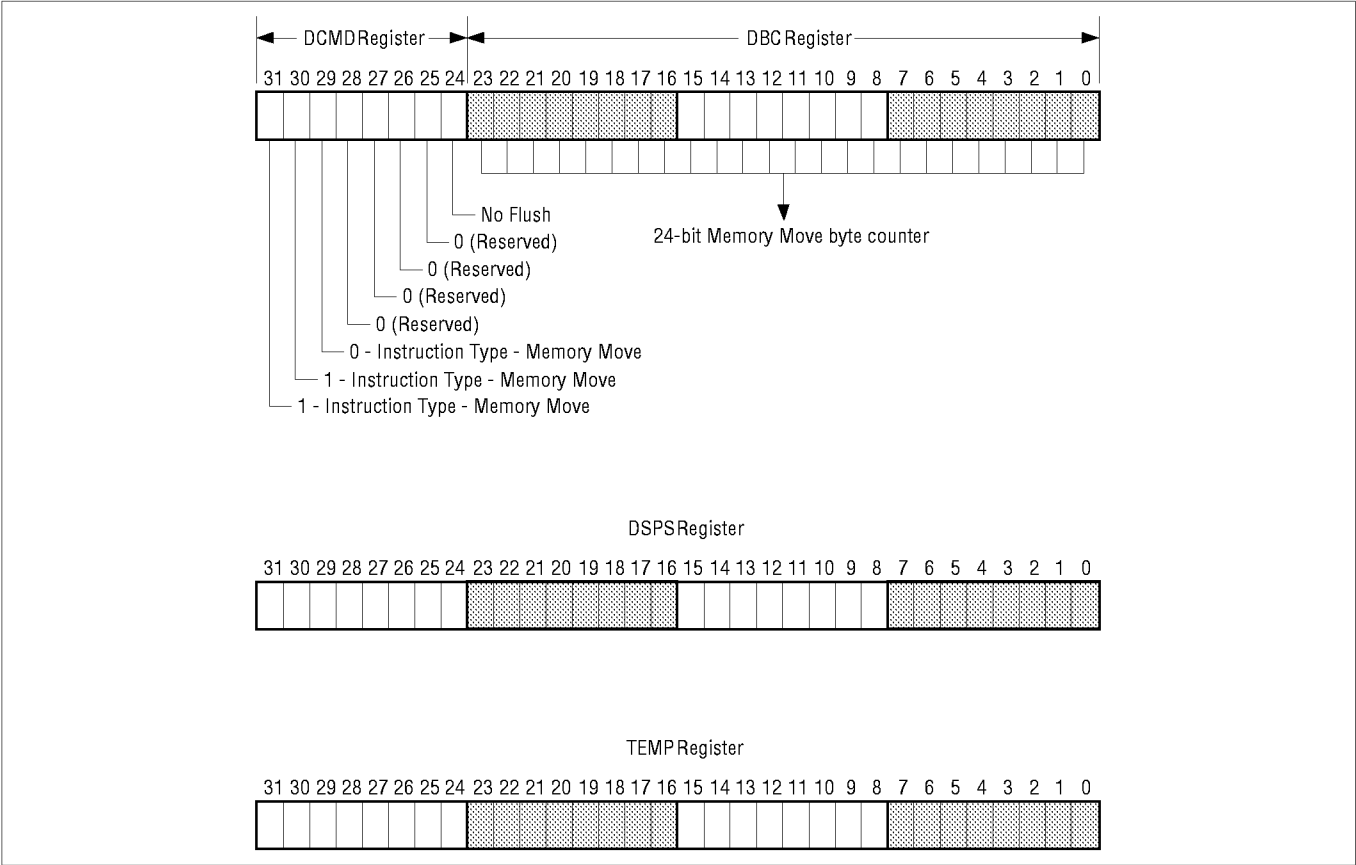

**Figure 5-6: Memory Move Instructions**

# Load and Store Instructions

The Load and Store instruction provides a more efficient way to move data from/to memory to/from an internal register in the chip without using the normal memory move instruction.

The load and store instructions are represented by two-dword op codes. The first dword contains the DCMD and DBC register values. The second dword contains the DSPS value. This is either the actual memory location of where to load or store, or the offset from the DSA, depending on the value of Bit 28 (DSA Relative).

A maximum of 4 bytes may be moved with these instructions. The register address and memory address must have the same byte alignment, and the count set such that it does not cross dword boundaries. The memory address may not map back to the chip, excluding RAM and ROM. If it does, a PCI read/write cycle occurs (the data does not actually transfer to/from the chip), and the chip issues an interrupt (Illegal Instruction Detected) immediately following.

Bits A1, A0	Number of bytes allowed to load/store
00	One, two, three or four
01	One, two, or three
10	One or two

Bits A1, A0	Number of bytes allowed to load/store
11	One

The SIOM and DIOM bits in the DMODE register determine whether the destination or source address of the instruction is in Memory space or I/O space, as illustrated in the following table. The Load/Store utilizes the PCI commands for I/O READ and I/O WRITE to access the I/O space.

**Table 5-2:**

Bit	Source	Destination
SIOM (Load)	memory	register
DIOM (Store)	register	memory

### First Dword

#### Bit 31-29 Instruction Type

These bits should be 111, indicating the Load and Store instruction.

#### Bit 28 DSA Relative

When this bit is clear, the value in the DSPS is the actual 32-bit memory address to perform the load/store to/from. When this bit is set, the chip determines the memory address to perform the load/store to/from by adding the 24-bit signed offset value in the DSPS to the DSA.

#### Bits 27-26 Reserved

#### Bit 25 No Flush (Store instruction only)

Note: This bit has no effect unless the Pre-fetch Enable bit in the DCNTL register is set. For information on SCRIPTS instruction prefetching, see Chapter 2.

When this bit is set, the SYM53C876 performs a Store without flushing the prefetch unit. When this bit is clear, the Store instruction automatically flushes the prefetch unit. Use No Flush if the source and destination are not within four instructions of the current Store instruction. This bit has no effect on

the Load instruction.

#### Bit 24 Load/Store

When this bit is set, the instruction is a Load. When cleared, it is a Store.

#### Bit 23 Reserved

#### Bits 22-16 Register Address

A6-A0 select the register to load/store to/from within the SYM53C876.

#### Bits 15-3 Reserved

#### Bits 2-0 Byte Count

This value is the number of bytes to load/store.

### Second Dword

#### Bits 31-0 Memory/IO Address / DSA Offset

This is the actual memory location of where to load or store, or the offset from the DSA register value.

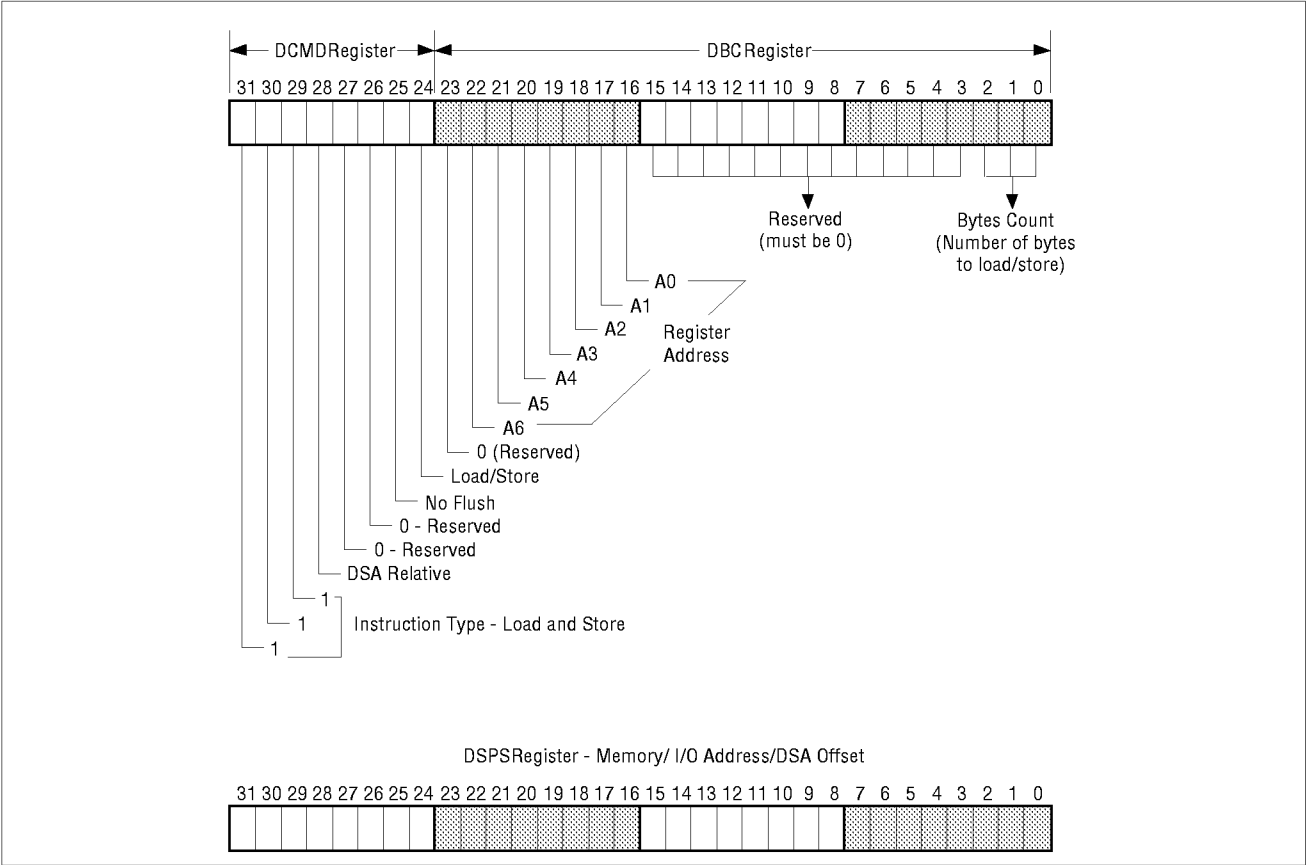

**Figure 5-7: Load and Store Instruction Format**





## Chapter 6

# Electrical Characteristics

## DC Characteristics

These characteristics apply whenever a VDD source of 5 volts is supplied to the pins below.

**Table 6-1: Absolute Maximum Stress Ratings**

Symbol	Parameter	Min	Max	Unit	Test Conditions
T <sub>STG</sub>	Storage temperature	-55	150	°C	-
V <sub>DD</sub>	Supply voltage	-0.5	7.0	V	-
V <sub>IN</sub>	Input Voltage	V <sub>SS</sub> - 0.5	V <sub>DD</sub> + 0.5	V	-
I <sub>LP</sub> *	Latch-up current	± 150	-	mA	-
ESD**	Electrostatic discharge	-	2K	V	MIL-STD 883C, Method 3015.7

*Stresses beyond those listed above may cause permanent damage to the device. These are stress ratings only; functional operation of the device at these or any other conditions beyond those indicated in the Operating Conditions section of the manual is not implied.*

\*  $-2V < V_{PIN} < 8V$

\*\* SCSI pins only

**Table 6-2: Operating Conditions**

Symbol	Parameter	Min	Max	Unit	Test Conditions
V <sub>DD</sub>	Supply voltage	4.75	5.25	V	-
I <sub>DD</sub>	Supply current (dynamic)	-	150	mA	-
	Supply current (static)	-	1	mA	-
T <sub>A</sub>	Operating free air	0	70	°C	-
U <sub>JA</sub>	Thermal resistance (junction to ambient air)	-	50	°C/W	-

*Conditions that exceed the operating limits may cause the device to function incorrectly*

**Table 6-3: SCSI Signals - SD(15-0)/, SDP(1-0)/, SREQ/ SACK/**

Symbol	Parameter	Min	Max	Unit	Test Conditions
V <sub>IH</sub>	Input high voltage	1.9	V <sub>DD</sub> + 0.5	V	-
V <sub>IL</sub>	Input low voltage	V <sub>SS</sub> - 0.5	1.0	V	-
V <sub>OH</sub> *	Output high voltage	2.5	3.5	V	2.5 mA
V <sub>OL</sub>	Output low voltage	V <sub>SS</sub>	0.5	V	48 mA
I <sub>OZ</sub>	Tristate leakage	-10	10	μA	-

\*TolerANT active negation enabled

**Table 6-4: SCSI Signals - SMSG, SI\_O/, SC\_D/, SATN/, SBSY/, SSEL/, SRST/**

Symbol	Parameter	Min	Max	Unit	Test Conditions
V <sub>IH</sub>	Input high voltage	1.9	V <sub>DD</sub> + 0.5	V	-
V <sub>IL</sub>	Input low voltage	V <sub>SS</sub> - 0.5	1.0	V	-
V <sub>OL</sub>	Output low voltage	V <sub>SS</sub>	0.5	V	48 mA
I <sub>OZ</sub>	Tristate leakage (SRST/ only)	-10 -500	10 -50	μA	-

**Table 6-5: Input Signals - CLK, SCLK, GNT/, IDSEL, RST/, TESTIN, DIFFSENS**

Symbol	Parameter	Min	Max	Unit	Test Conditions
V <sub>IH</sub>	Input high voltage	2.0	V <sub>DD</sub> + 0.5	V	-
V <sub>IL</sub>	Input low voltage	V <sub>SS</sub> - 0.5	0.8	V	-
I <sub>IN</sub>	Input leakage	-10	10	μA	-

Note: SCLK and RST/ have a 100 μA pull-ups that are enabled when TESTIN is low. GNT/ and IDSEL have 25 μA pull-ups that are enabled when TESTIN is low. TESTIN has a 100 μA pull-up that is always enabled.

**Table 6-6: Capacitance**

Symbol	Parameter	Min	Max	Unit	Test Conditions
$C_I$	Input capacitance of input pads	-	7	pF	-
$C_{IO}$	Input capacitance of I/O pads	-	10	pF	-

**Table 6-7: Output Signal - INTA/, INTB/**

Symbol	Parameter	Min	Max	Unit	Test Conditions
$V_{OH}$	Output high voltage	2.4	$V_{DD}$	V	-16 mA
$V_{OL}$	Output low voltage	$V_{SS}$	0.4	V	16 mA
$I_{OZ}$	Tristate leakage	-200	-50	$\mu A$	-

*Note: INTA/ and INTB/ have 100  $\mu A$  pull-ups that are enabled when TESTIN is low. INTA/ and INTB/ can be enabled with a register bit as an open drain output with an internal 100  $\mu A$  pull-up.*

**Table 6-8: Output Signals - SDIR(15-0), SDIRP0/1, BSYDIR, SELDIR, RSTDIR, TGS, IGS, MAS/(1-0), MCE/, MOE/\_TESTOUT, MWE/**

Symbol	Parameter	Min	Max	Unit	Test Conditions
V <sub>OH</sub>	Output high voltage	2.4	V <sub>DD</sub>	V	-4 mA
V <sub>OL</sub>	Output low voltage	V <sub>SS</sub>	0.4	V	4 mA
I <sub>OZ</sub>	Tristate leakage	-10	10	μA	-

Note: Each of these output signals have a 100 μA pull-up that is enabled when TESTIN is low.

**Table 6-9: Output Signal - REQ/**

Symbol	Parameter	Min	Max	Unit	Test Conditions
V <sub>OH</sub>	Output high voltage	2.4	V <sub>DD</sub>	V	-16 mA
V <sub>OL</sub>	Output low voltage	V <sub>SS</sub>	0.4	V	16 mA
I <sub>OZ</sub>	Tristate leakage	-10	10	μA	-

Note: REQ/ has a 25 μA pull-up that is enabled when TESTIN is low.

**Table 6-10: Output Signal - SERR/**

Symbol	Parameter	Min	Max	Unit	Test Conditions
V <sub>OL</sub>	Output low voltage	V <sub>SS</sub>	0.4	V	16 mA
I <sub>OZ</sub>	Tristate leakage	-10	10	μA	-

Note: SERR/ has a 25 μA pull-up that is enabled when TESTIN is low.

**Table 6-11: Bidirectional Signals - AD(31-0), C\_BE/(3-0), FRAME/, IRDY/, TRDY/, DEVSEL/, STOP/, PERR/, PAR**

Symbol	Parameter	Min	Max	Unit	Test Conditions
V <sub>IH</sub>	Input high voltage	2.0	V <sub>DD</sub> + 0.5	V	-
V <sub>IL</sub>	Input low voltage	V <sub>SS</sub> - 0.5	0.8	V	-

Note: All the signals in this table have 25 μA pull-ups that are enabled when TESTIN is low

**Table 6-11: Bidirectional Signals - AD(31-0), C\_BE/(3-0), FRAME/, IRDY/, TRDY/, DEVSEL/, STOP/, PERR/, PAR**

Symbol	Parameter	Min	Max	Unit	Test Conditions
V <sub>OH</sub>	Output high voltage	2.4	V <sub>DD</sub>	V	16 mA
V <sub>OL</sub>	Output low voltage	V <sub>SS</sub>	0.4	V	16 mA
I <sub>OZ</sub>	Tristate leakage	-10	10	μA	-

Note: All the signals in this table have 25 μA pull-ups that are enabled when TESTIN is low

**Table 6-12: Bidirectional Signals - GPIO0\_FETCH/, GPIO1\_MASTER/, GPIO2, GPIO3, GPIO4**

Symbol	Parameter	Min	Max	Unit	Test Conditions
V <sub>IH</sub>	Input high voltage	2.0	V <sub>DD</sub> + 0.5	V	-
V <sub>IL</sub>	Input low voltage	V <sub>SS</sub> - 0.5	0.8	V	-
V <sub>OH</sub>	Output high voltage	2.4	V <sub>DD</sub>	V	-16 mA
V <sub>OL</sub>	Output low voltage	V <sub>SS</sub>	0.4	V	16 mA
I <sub>OZ</sub>	Tristate leakage	-200	50	μA	-

**Table 6-13: Bidirectional Signals - MAD(7-0)**

Symbol	Parameter	Min	Max	Unit	Test Conditions
V <sub>IH</sub>	Input high voltage	2.0	V <sub>DD</sub> + 0.5	V	-
V <sub>IH</sub>	Input high voltage - external memory pull-downs	3.85	V <sub>DD</sub> + 0.5	V	-
V <sub>IL</sub>	Input low voltage	V <sub>SS</sub> - 0.5	0.8	V	-
V <sub>IL</sub>	Input low voltage - external memory pull-downs	V <sub>SS</sub> - 0.5	1.35	V	-
V <sub>OH</sub>	Output high voltage	2.4	V <sub>DD</sub>	V	-4 mA
V <sub>OL</sub>	Output low voltage	V <sub>SS</sub>	0.4	V	4 mA
I <sub>OZ</sub>	Tristate leakage	-200	50	μA	-

**Table 6-14: Input Signals — TDI, TMS, TCK**

Symbol	Parameter	Min	Max	Unit	Test Conditions
$V_{IH}$	Input high voltage	2.0	$V_{DD} + 0.5$	V	-
$V_{IL}$	Input low voltage	$V_{SS} - 0.5$	0.8	V	-
$I_{IN}$	Input leakage	-200	-50	$\mu A$	-

**Table 6-15: Output Signal — TDO**

Symbol	Parameters	Min	Max	Units	Test Conditions
$V_{OH}$	Output high voltage	$V_{DD} - 0.5$	$V_{DD}$	V	-4 mA
$V_{OL}$	Output low voltage	$V_{SS}$	0.5	V	4 mA
$I_{OZ}$	Tristate leakage	-10	10	$\mu A$	-

## 3.3 Volt PCI DC Characteristics

These characteristics apply whenever a VDD source of 3.3 volts is supplied to the VDD-I pins of the SYM53C876.

**Table 6-16: Bidirectional Signals—AD(31-0), C\_BE(3-0)/, FRAME/, IRDY/, TRDY/, DEVSEL/, STOP/, PERR/, PAR**

Symbol	Parameter	Min	Max	Units	Test Conditions
V <sub>IH</sub>	Input high voltage	0.5 V <sub>DD</sub>	V <sub>DD</sub> + 0.5	V	-
V <sub>IL</sub>	Input low voltage	-0.5	0.3 V <sub>DD</sub>	V	-
V <sub>OH</sub>	Output high voltage	0.9 V <sub>DD</sub>	-	V	I <sub>OH</sub> =-0.5 mA
V <sub>OL</sub>	Output low voltage	-	0.1 V <sub>DD</sub>	V	I <sub>OL</sub> =1.5 mA
I <sub>OZ</sub>	Tristate leakage	-10	10	μA	-

**Table 6-17: Input Signals—CLK, GNT/, IDSEL, RST/**

Symbol	Parameter	Min	Max	Units	Test Conditions
V <sub>IH</sub>	Input high voltage	0.5 V <sub>DD</sub>	V <sub>DD</sub> + 0.5	V	-
V <sub>IL</sub>	Input low voltage	-0.5	0.3 V <sub>DD</sub>	V	-
I <sub>IN</sub>	Input leakage	-10	10	μA	-

**Table 6-18: Output Signals—INTA/, INTB, REQ/**

Symbol	Parameter	Min	Max	Units	Test Conditions
V <sub>OH</sub>	Output high voltage	0.9 V <sub>DD</sub>	-	V	I <sub>OH</sub> =-0.5 mA
V <sub>OL</sub>	Output low voltage	-	0.1 V <sub>DD</sub>	V	I <sub>OL</sub> =1.5 mA
I <sub>OZ</sub>	Tristate leakage	-10	10	μA	-

**Table 6-19: Output Signal—SERR/**

Symbol	Parameter	Min	Max	Units	Test Conditions
$V_{OL}$	Output low voltage	-	$0.1 V_{DD}$	V	$I_{OL}=1.5 \text{ mA}$
$I_{OZ}$	Tristate leakage	-10	10	$\mu\text{A}$	-



# TolerANT Technology Electrical Characteristics

Note: TolerANT applies only to the SCSI bus.

**Table 6-20: TolerANT Technology Electrical Characteristics**

Symbol	Parameter	Min	Max	Units	Test Conditions
$V_{OH}^1$	Output high voltage	2.5	3.5	V	$I_{OH} = 2.5 \text{ mA}$
$V_{OL}$	Output low voltage	0.1	0.5	V	$I_{OL} = 48 \text{ mA}$
$V_{IH}$	Input high voltage	2.0	7.0	V	-
$V_{IL}$	Input low voltage	-0.5	0.8	V	Referenced to $V_{SS}$
$V_{IK}$	Input clamp voltage	-0.66	-0.77	V	$V_{DD} = 4.75$ ; $I_I = -20 \text{ mA}$
$V_{TH}$	Threshold, high to low	1.1	1.3	V	-
$V_{TL}$	Threshold, low to high	1.5	1.7	V	-
$V_{TH} - V_{TL}$	Hysteresis	200	400	mV	-
$I_{OH}^1$	Output high current	2.5	24	mA	$V_{OH} = 2.5 \text{ V}$
$I_{OL}$	Output low current	100	200	mA	$V_{OL} = 0.5 \text{ V}$
$I_{OSH}^1$	Short-circuit output high current	-	625	mA	Output driving low, pin shorted to $V_{DD}$ supply <sup>2</sup>
$I_{OSL}$	Short-circuit output low current	-	95	mA	Output driving high, pin shorted to $V_{SS}$ supply
$I_{LH}$	Input high leakage	-	10	$\mu\text{A}$	$-0.5 < V_{DD} < 5.25$ $V_{PIN} = 2.7 \text{ V}$
$I_{LL}$	Input low leakage	-	-10	$\mu\text{A}$	$-0.5 < V_{DD} < 5.25$ $V_{PIN} = 0.5 \text{ V}$
$R_I$	Input resistance	20	-	$\text{M}\Omega$	SCSI pins <sup>3</sup>
$C_p$	Capacitance per pin	-	10	pF	PQFP
$t_R^1$	Rise time, 10% to 90%	9.7	18.5	ns	Figure 7-1
$t_F$	Fall time, 90% to 10%	5.2	14.7	ns	Figure 7-1
$dV_H/dt$	Slew rate, low to high	0.15	0.49	V/ns	Figure 7-1
$dV_L/dt$	Slew rate, high to low	0.19	0.67	V/ns	Figure 7-1
ESD	Electrostatic discharge	2	-	KV	MIL-STD-883C; 3015-7
	Latch-up	150	-	mA	-

Note: These values are guaranteed by periodic characterization; they are not 100% tested on every device.

<sup>1</sup> Active negation outputs only: Data, Parity, SREQ/, SACK/

<sup>2</sup> Single pin only; irreversible damage may occur if sustained for one second

<sup>3</sup> SCSI RESET pin has 10 k $\Omega$  pull-up resistor

**Table 6-20: TolerANT Technology Electrical Characteristics**

Symbol	Parameter	Min	Max	Units	Test Conditions
	Filter delay	20	30	ns	Figure 7-2
	Extended filter delay	40	60	ns	Figure 7-2

*Note: These values are guaranteed by periodic characterization; they are not 100% tested on every device.*

<sup>1</sup> Active negation outputs only: Data, Parity, SREQ/, SACK/

<sup>2</sup> Single pin only; irreversible damage may occur if sustained for one second

<sup>3</sup> SCSI RESET pin has 10 kΩ pull-up resistor

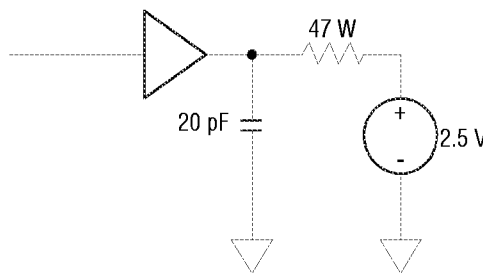

**Figure 6-1: Rise and Fall Time Test Conditions**

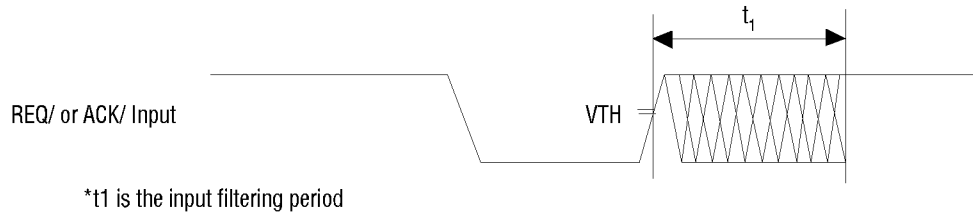

**Figure 6-2: SCSI Input Filtering**

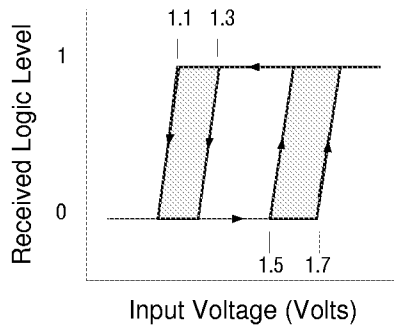

**Figure 6-3: Hysteresis of SCSI Receiver**

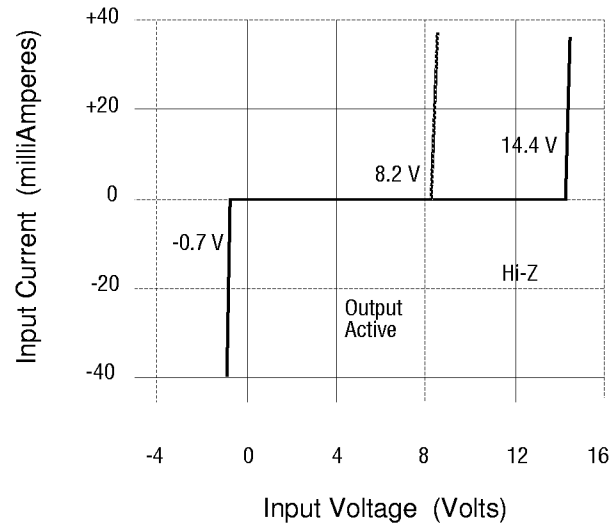

**Figure 6-4: Input Current as a Function of Input Voltage**

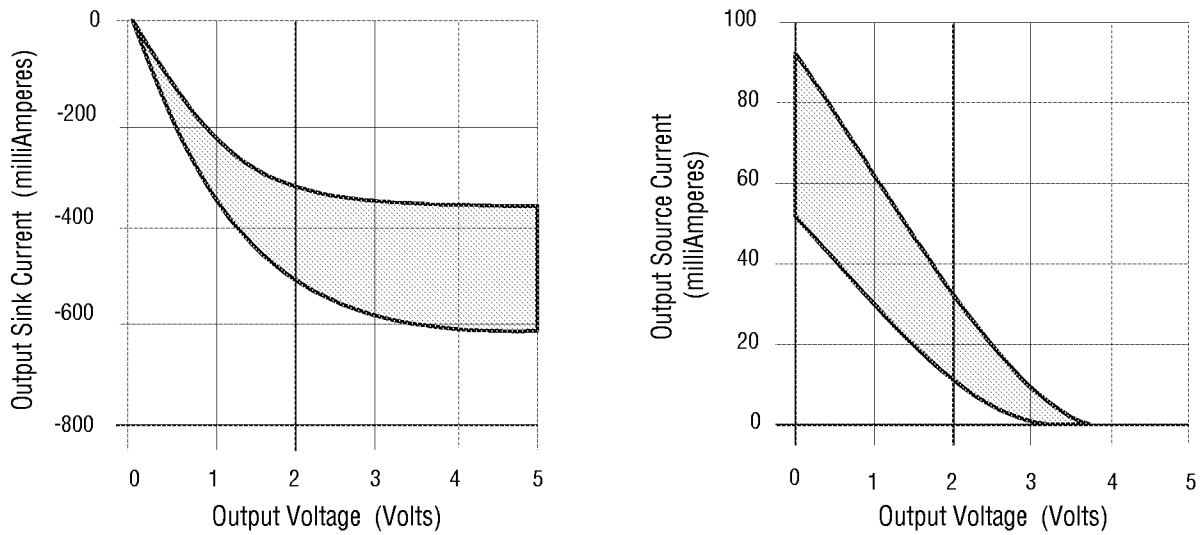

**Figure 6-5: Output Current as a Function of Output Voltage**

## AC Characteristics

The AC characteristics described in this section apply over the entire range of operating conditions (refer to the DC Characteristics section). Chip timings are based on simulation at worst case voltage, temperature, and processing.

This part of the chapter contains AC Characteristics for the PCI Interface, and the SCSI Interface.

**Table 6-21: Clock Timing**

Symbol	Parameter	Min	Max	Units
$t_1$	Bus clock cycle time	30	DC	ns
	SCSI clock cycle time (SCLK)*	15	60	ns
$t_2$	CLK low time**	11	-	ns
	SCLK low time**	6	33	ns
$t_3$	CLK high time**	11	-	ns
	SCLK high time**	6	33	ns
$t_4$	CLK slew rate	1	-	V/ns
	SCLK slew rate	1	-	ns

\*This parameter must be met to insure SCSI timings are within specification

\*\*Duty cycle not to exceed 60/40

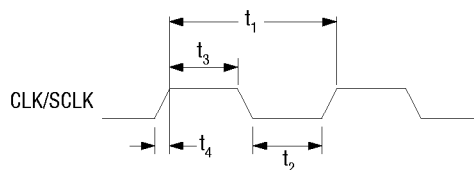

**Figure 6-6: Clock Timing**

**Table 6-22: Reset Input**

Symbol	Parameter	Min	Max	Units
$t_1$	Reset Pulse Width	10	-	tclk
$t_2$	Reset deasserted setup to CLK high	0	-	ns
$t_3$	MAD setup time to CLK high (for configuring the MAD bus only)	20	-	ns
$t_4$	MAD hold time from CLK high (for configuring the MAD bus only)	20	-	ns

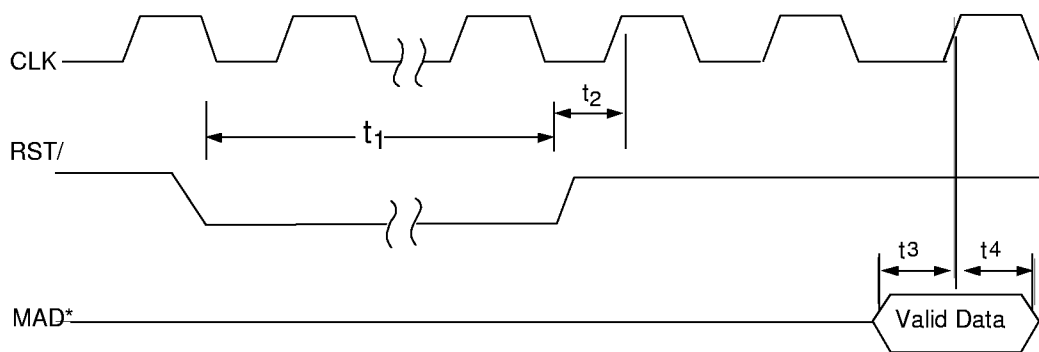

\* When enabled

**Figure 6-7: Reset Input**

**Table 6-23: Interrupt Output**

Symbol	Parameter	Min	Max	Units
$t_1$	CLK high to IRQ/ low	20	-	ns
$t_2$	CLK high to IRQ/ high	40	-	ns
$t_3$	INTA/, INTB/ deassertion time	3	-	CLKs

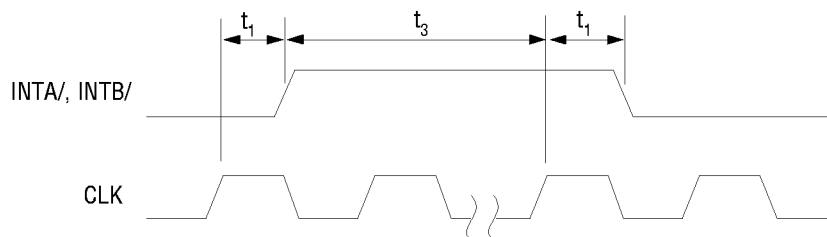

**Figure 6-8: Interrupt Output**

## PCI and External Memory Interface Timings

This section includes timing diagrams for access to three groups of external memory configurations. The first group applies to systems with memory size of 128 KB and above; one byte read or write cycle, and fast or normal ROMs. The second group applies to system with memory size of 128 KB and above, one-byte read or write cycles, and slow ROMs. The third group applies to systems with memory size of 64 KB or less, one-byte read or write cycles, and normal or fast ROM.

Note: Multiple byte access to the external memory bus increase the read or write cycle by 11 clocks for each additional byte. For your convenience, we have created one table with all the symbols and parameters for all the timing diagrams as well as included a table per each timing diagram.

### Timing diagrams included in this section

- PCI configuration register read
- PCI configuration register write
- Target Read, without external memory
- Target Write, without external memory
- Target Read, with external memory
- Target Write, with external memory
- Op Code Fetch, non-Burst
- Op Code Ftech, Burst
- Back-to-Back Read
- Back-to-Back Write
- Read Cycle, normal/fast ROM, single-byte access
- Write Cycle, normal/fast ROM, single-byte access
- Read Cycle, normal/fast ROM, multiple-byte access
- Write Cycle, normal/fast ROM, multiple-byte access
- Read Cycle, slow memory
- Write Cycle, slow memory
- Read Cycle, 16 KB ROM
- Write Cycle, 16 KB ROM

### 3.3 Volt PCI Timings

Note: When a 3.3 Volt source is applied to the  $V_{DD-I}$  pins of the SYM53C876, some of the PCI timings in Tables 6-24 through 6-35 will change. These 3.3 Volt PCI timings are as follows:

Symbol	Parameter	Min	Max	Unit
$t_2$	Shared signal input hold time	1	-	ns

$t_3$	CLK to shared signal output valid	-	12	ns
-------	-----------------------------------	---	----	----

**Table 6-24: Configuration Register Read**

Symbol	Parameter	Min	Max	Unit
$t_1$	Shared signal input setup time	7	-	ns
$t_2$	Shared signal input hold time	0	-	ns
$t_3$	CLK to shared signal output valid	-	11	ns

See Note on page 6-15 regarding 3.3 Volt PCI timing changes.

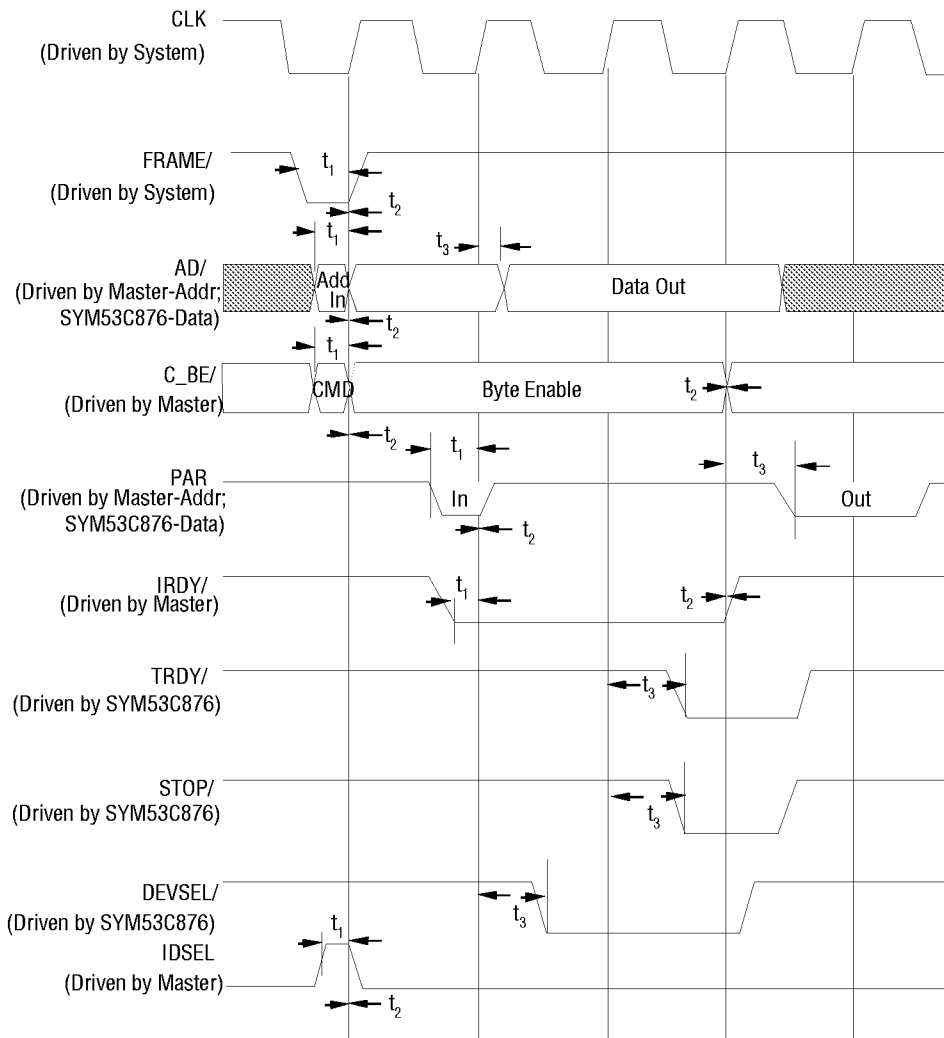

**Figure 6-9: Configuration Register Read**



**Table 6-25: Configuration Register Write**

Symbol	Parameter	Min	Max	Unit
$t_1$	Shared signal input setup time	7	-	ns
$t_2$	Shared signal input hold time	0	-	ns
$t_3$	CLK to shared signal output valid	-	11	ns

See Note on page 6-15 regarding 3.3 Volt PCI timing changes.

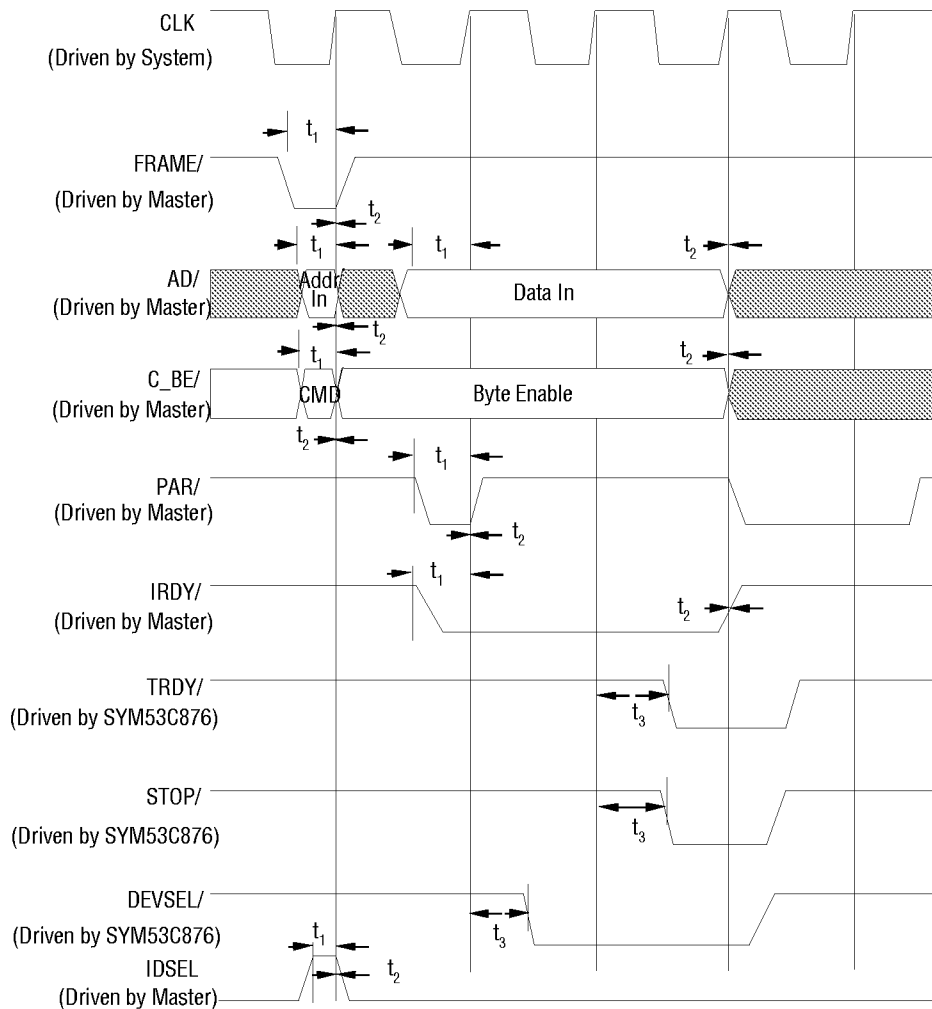
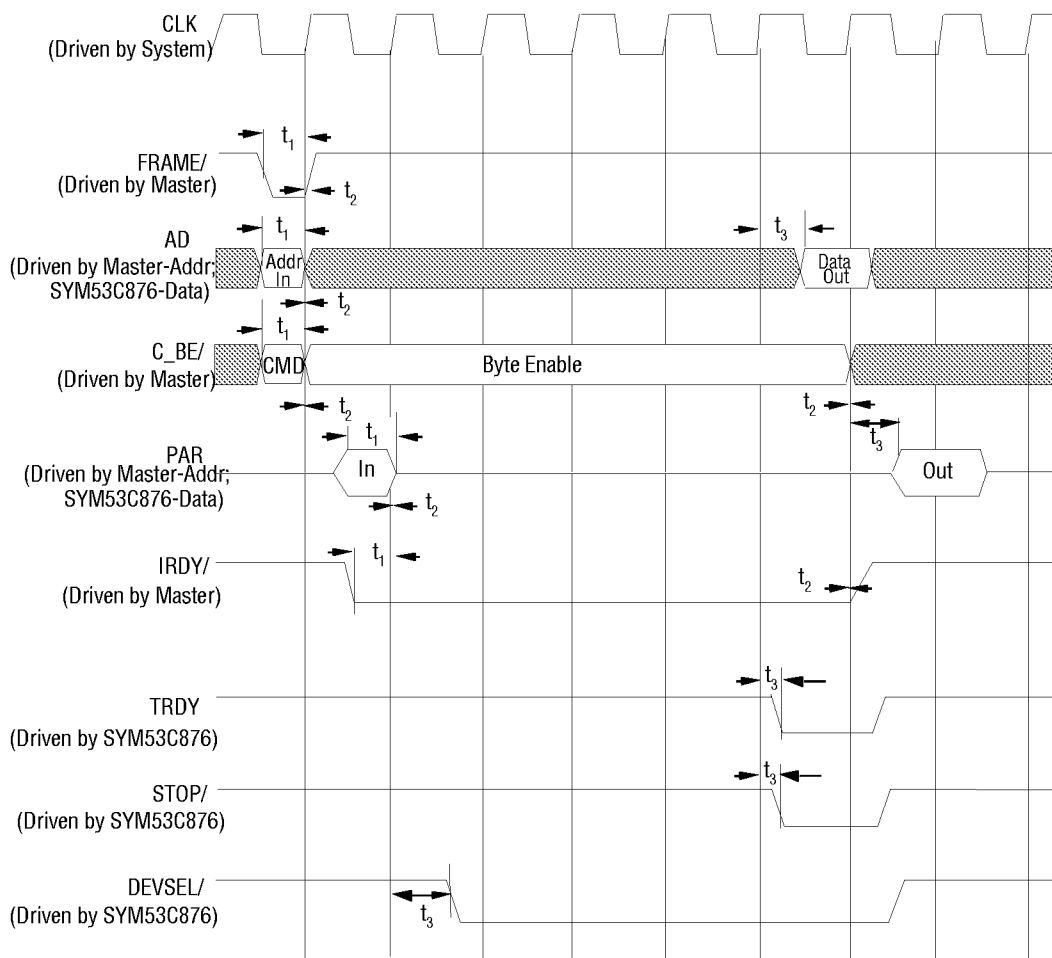

**Figure 6-10: Configuration Register Write**

**Table 6-26: Target Read, not from external memory**

Symbol	Parameter	Min	Max	Unit
$t_1$	Shared signal input setup time	7	-	ns
$t_2$	Shared signal input hold time	0	-	ns
$t_3$	CLK to shared signal output valid	-	11	ns

See Note on page 6-15 regarding 3.3 Volt PCI timing changes.

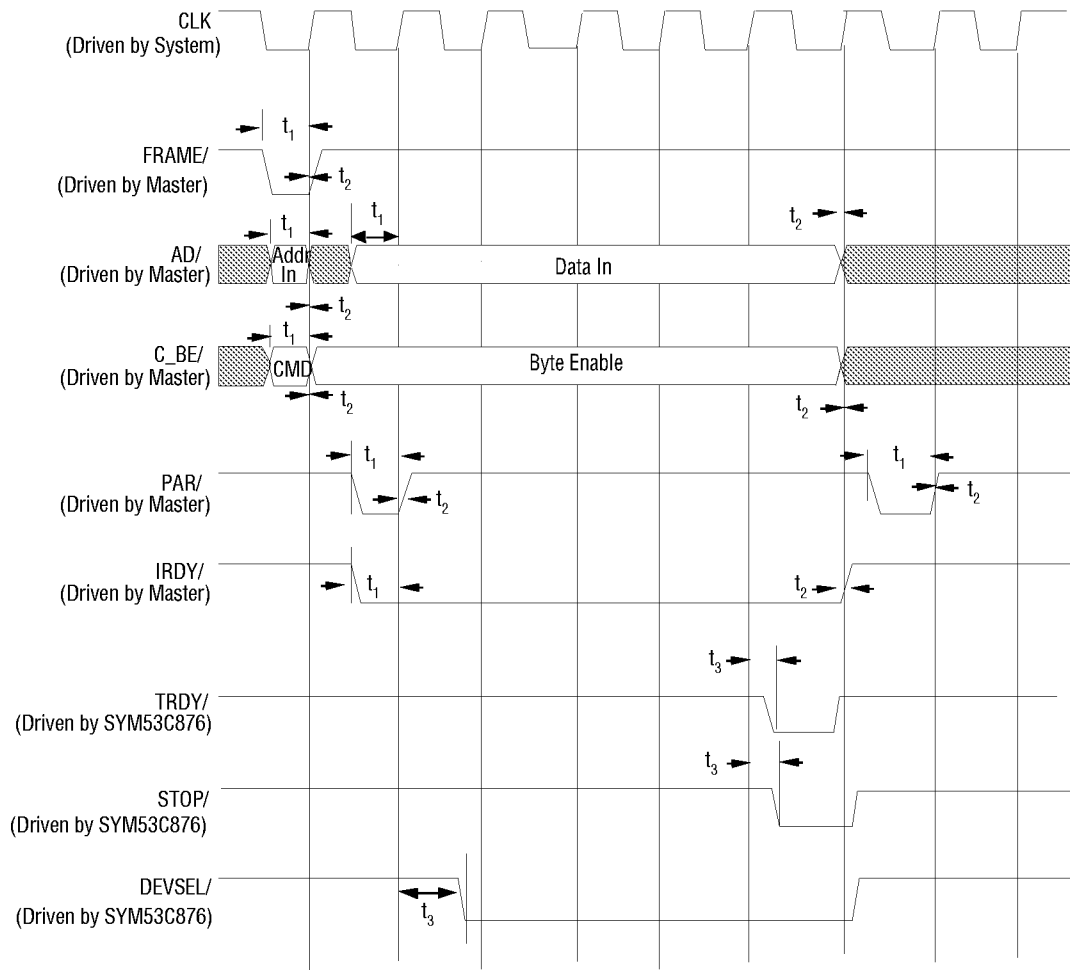

**Figure 6-11: Target Read, not from external memory**

**Table 6-27: Target Write, not from external memory**

Symbol	Parameter	Min	Max	Unit
$t_1$	Shared signal input setup time	7	-	ns
$t_2$	Shared signal input hold time	0	-	ns
$t_3$	CLK to shared signal output valid	-	11	ns

See Note on page 6-15 regarding 3.3 Volt PCI timing changes.



**Figure 6-12: Target Write, not from external memory**

**Table 6-28: Target Read, from external memory**

Symbol	Parameter	Min	Max	Unit
t <sub>1</sub>	Shared signal input setup time	7	-	ns
t <sub>2</sub>	Shared signal input hold time	0	-	ns
t <sub>3</sub>	CLK to shared signal output valid	-	11	ns
t <sub>4</sub>	Side signal input setup time	10	-	ns
t <sub>11</sub>	Address setup to MAS/ high	25	-	ns
t <sub>12</sub>	Address hold from MAS/ high	15	-	ns
t <sub>13</sub>	MAS/ pulse width	25	-	ns
t <sub>14</sub>	MCE/ low to data clocked in	160	-	ns
t <sub>15</sub>	Address valid to data clocked in	205	-	ns
t <sub>16</sub>	MOE/ low to data clocked in	100	-	ns
t <sub>17</sub>	Data hold from address, MOE/, MCE/ change	0	-	ns
t <sub>18</sub>	Address out from MOE/, MCE/ high	50	-	ns
t <sub>19</sub>	Data setup to CLK high	5	-	ns

*See Note on page 6-15 regarding 3.3 Volt PCI timing changes.*

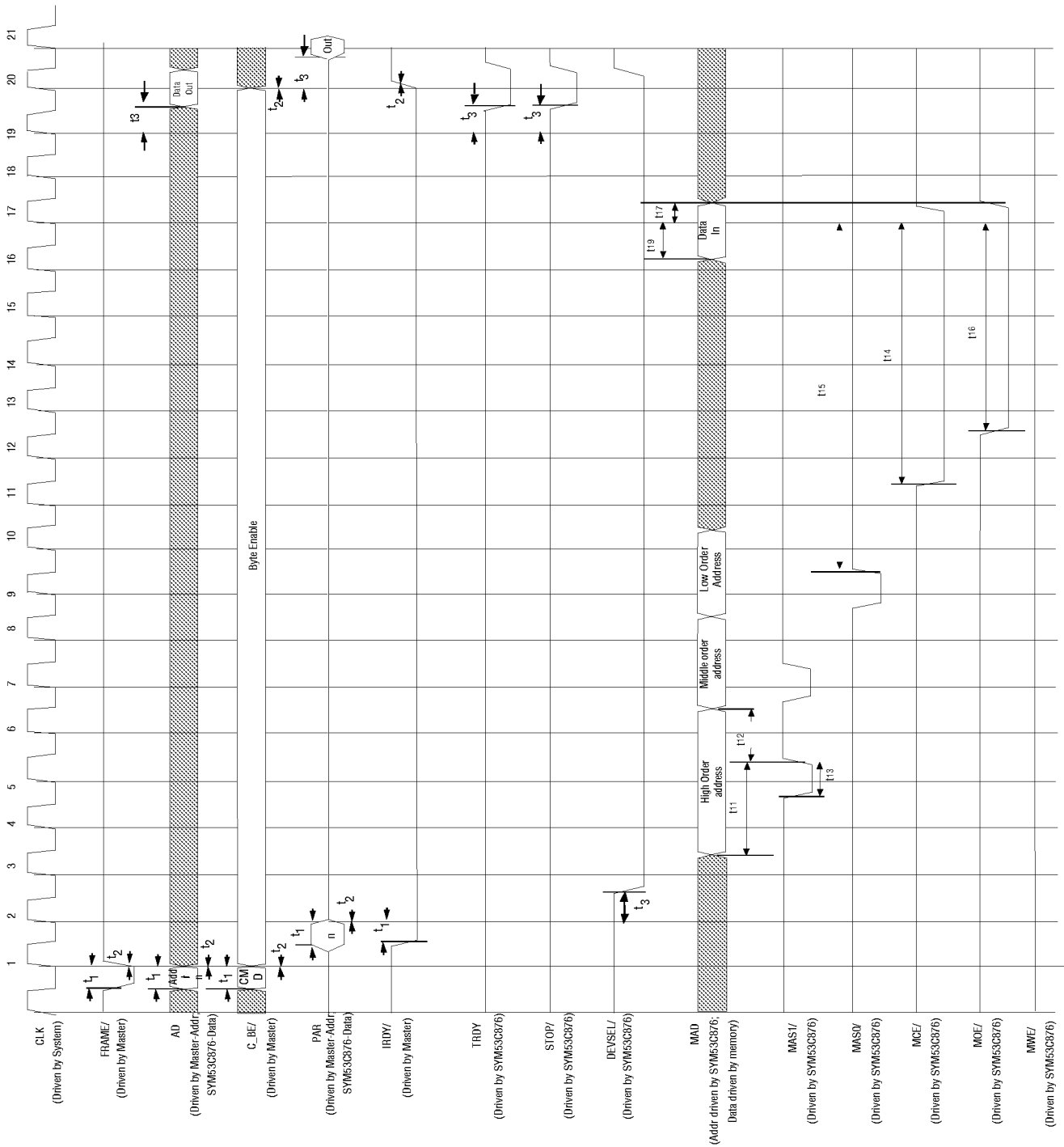

Figure 6-13: Target Read, from external memory

**Table 6-29: Target Write, from external memory**

Symbol	Parameter	Min	Max	Unit
t <sub>1</sub>	Shared signal input setup time	7	-	ns
t <sub>2</sub>	Shared signal input hold time	0	-	ns
t <sub>3</sub>	CLK to shared signal output valid	-	11	ns
t <sub>11</sub>	Address setup to MAS/ high	25	-	ns
t <sub>12</sub>	Address hold from MAS/ high	15	-	ns
t <sub>13</sub>	MAS/ pulse width	25	-	ns
t <sub>20</sub>	Data setup to MWE/ low	30	-	ns
t <sub>21</sub>	Data hold from MWE/ high	20	-	ns
t <sub>22</sub>	MWE/ pulse width	100	-	ns
t <sub>23</sub>	Address setup to MWE/ low	75	-	ns
t <sub>24</sub>	MCE/ low to MWE/ high	120	-	ns
t <sub>25</sub>	MCE/ low to MWE/ low	25	-	ns
t <sub>26</sub>	MWE/ high to MCE/ high	25	-	ns

*See Note on page 6-15 regarding 3.3 Volt PCI timing changes.*

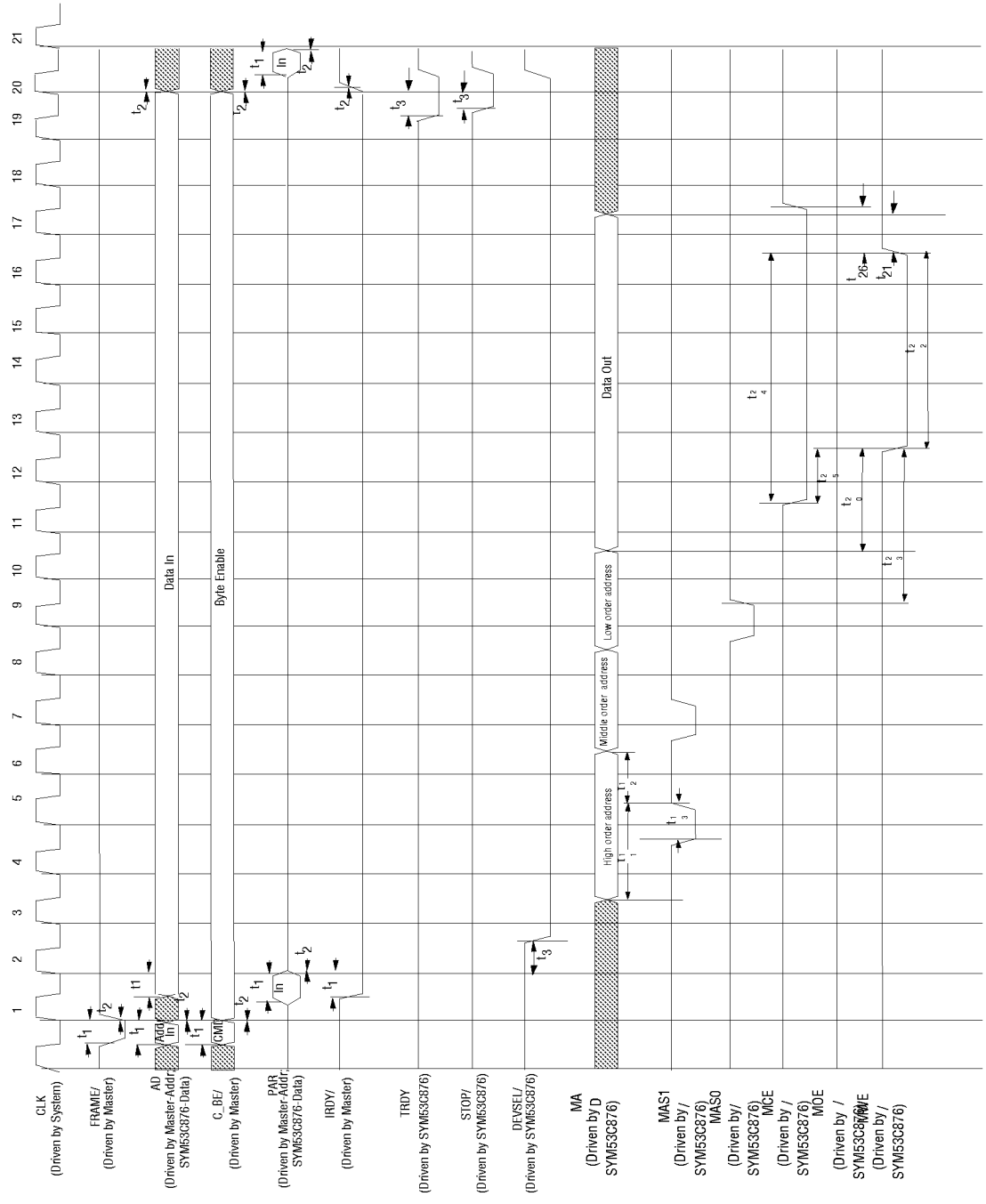

Figure 6-14: Target Write, from external memory

**Table 6-30: Op Code Fetch, non-Burst**

Symbol	Parameter	Min	Max	Unit
t <sub>1</sub>	Shared signal input setup time	7	-	ns
t <sub>2</sub>	Shared signal input hold time	0	-	ns
t <sub>3</sub>	CLK to shared signal output valid	-	11	ns
t <sub>4</sub>	Side signal input setup time	10	-	ns
t <sub>5</sub>	Side signal input hold time	0	-	ns
t <sub>6</sub>	CLK to side signal output valid	-	12	ns
t <sub>7</sub>	CLK high to FETCH/ low	-	20	ns
t <sub>8</sub>	CLK high to FETCH/ high	-	20	ns
t <sub>9</sub>	CLK high to MASTER/ low	-	20	ns
t <sub>10</sub>	CLK high to MASTER/ high	-	20	ns

*See Note on page 6-15 regarding 3.3 Volt PCI timing changes.*



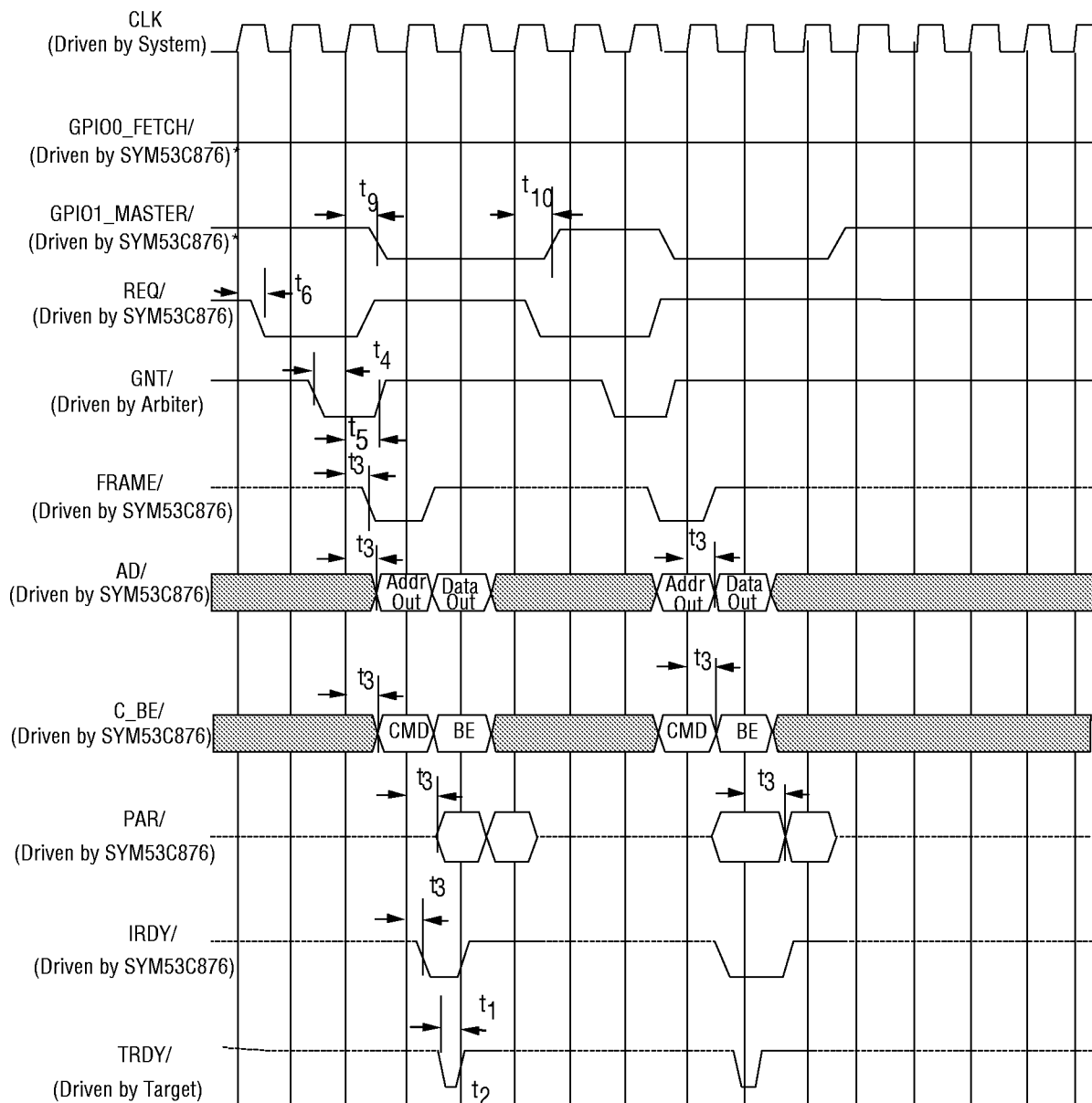

Figure 6-15: Op Code Fetch, non-Burst

**Table 6-31: Op Code Fetch, Burst**

Symbol	Parameter	Min	Max	Unit
t <sub>1</sub>	Shared signal input setup time	7	-	ns
t <sub>2</sub>	Shared signal input hold time	0	-	ns
t <sub>3</sub>	CLK to shared signal output valid	-	11	ns
t <sub>4</sub>	Side signal input setup time	10	-	ns
t <sub>5</sub>	Side signal input hold time	0	-	ns
t <sub>6</sub>	CLK to side signal output valid	-	12	ns
t <sub>7</sub>	CLK high to FETCH/ low	-	20	ns
t <sub>8</sub>	CLK high to FETCH/ high	-	20	ns
t <sub>9</sub>	CLK high to MASTER/ low	-	20	ns
t <sub>10</sub>	CLK high to MASTER/ high	-	20	ns

*See Note on page 6-15 regarding 3.3 Volt PCI timing changes.*

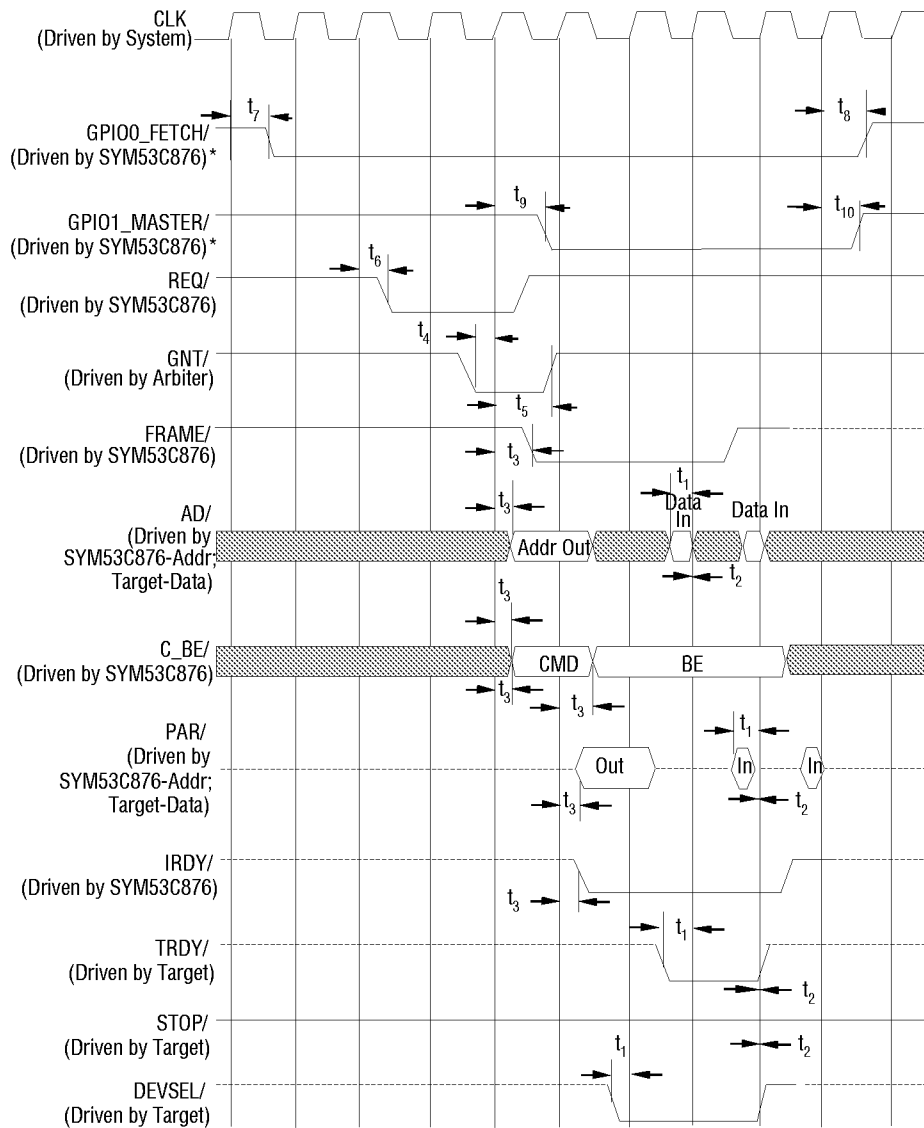

Figure 6-16: Op Code Fetch, Burst

**Table 6-32: Back to Back Read**

Symbol	Parameter	Min	Max	Unit
t <sub>1</sub>	Shared signal input setup time	7	-	ns
t <sub>2</sub>	Shared signal input hold time	0	-	ns
t <sub>3</sub>	CLK to shared signal output valid	-	11	ns
t <sub>4</sub>	Side signal input setup time	10	-	ns
t <sub>5</sub>	Side signal input hold time	0	-	ns
t <sub>6</sub>	CLK to side signal output valid	-	12	ns
t <sub>9</sub>	CLK high to MASTER/ low	-	20	ns
t <sub>10</sub>	CLK high to MASTER/ high	-	20	ns

*See Note on page 6-15 regarding 3.3 Volt PCI timing changes.*

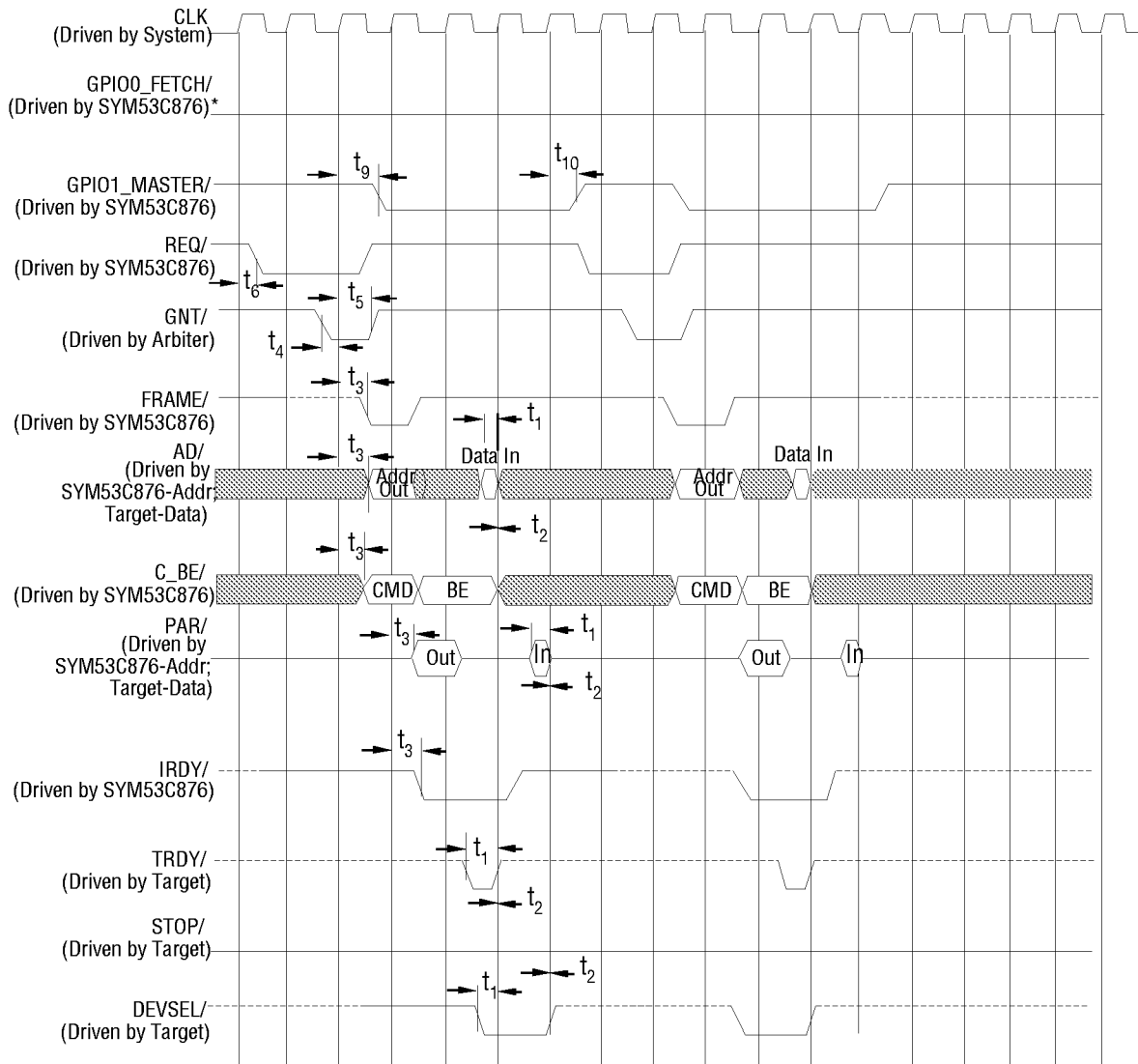

Figure 6-17: Back to Back Read

**Table 6-33: Back to Back Write**

Symbol	Parameter	Min	Max	Unit
t <sub>1</sub>	Shared signal input setup time	7	-	ns
t <sub>2</sub>	Shared signal input hold time	0	-	ns
t <sub>3</sub>	CLK to shared signal output valid	-	11	ns
t <sub>4</sub>	Side signal input setup time	10	-	ns
t <sub>5</sub>	Side signal input hold time	0	-	ns
t <sub>6</sub>	CLK to side signal output valid	-	12	ns
t <sub>9</sub>	CLK high to MASTER/ low	-	20	ns
t <sub>10</sub>	CLK high to MASTER/ high	-	20	ns

*See Note on page 6-15 regarding 3.3 Volt PCI timing changes.*

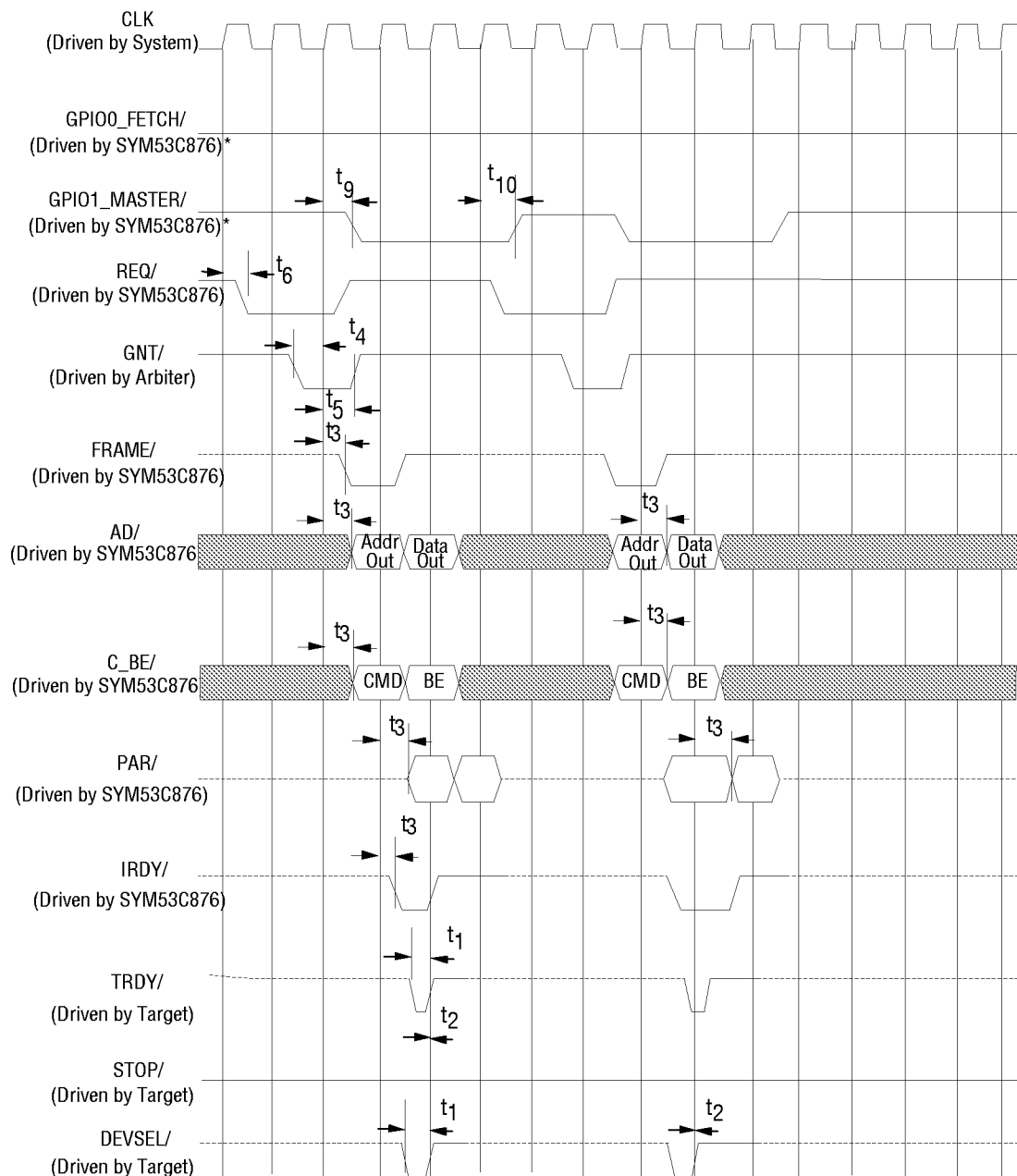

Figure 6-18: Back to Back Write

**Table 6-34: Burst Read**

<b>Symbol</b>	<b>Parameter</b>	<b>Min</b>	<b>Max</b>	<b>Unit</b>
t <sub>1</sub>	Shared signal input setup time	7	-	ns
t <sub>2</sub>	Shared signal input hold time	0	-	ns
t <sub>3</sub>	CLK to shared signal output valid	-	11	ns
t <sub>4</sub>	Side signal input setup time	10	-	ns
t <sub>5</sub>	Side signal input hold time	0	-	ns
t <sub>6</sub>	CLK to side signal output valid	-	12	ns
t <sub>9</sub>	CLK high to MASTER/ low	-	20	ns
t <sub>10</sub>	CLK high to MASTER/ high	-	20	ns

*See Note on page 6-15 regarding 3.3 Volt PCI timing changes.*



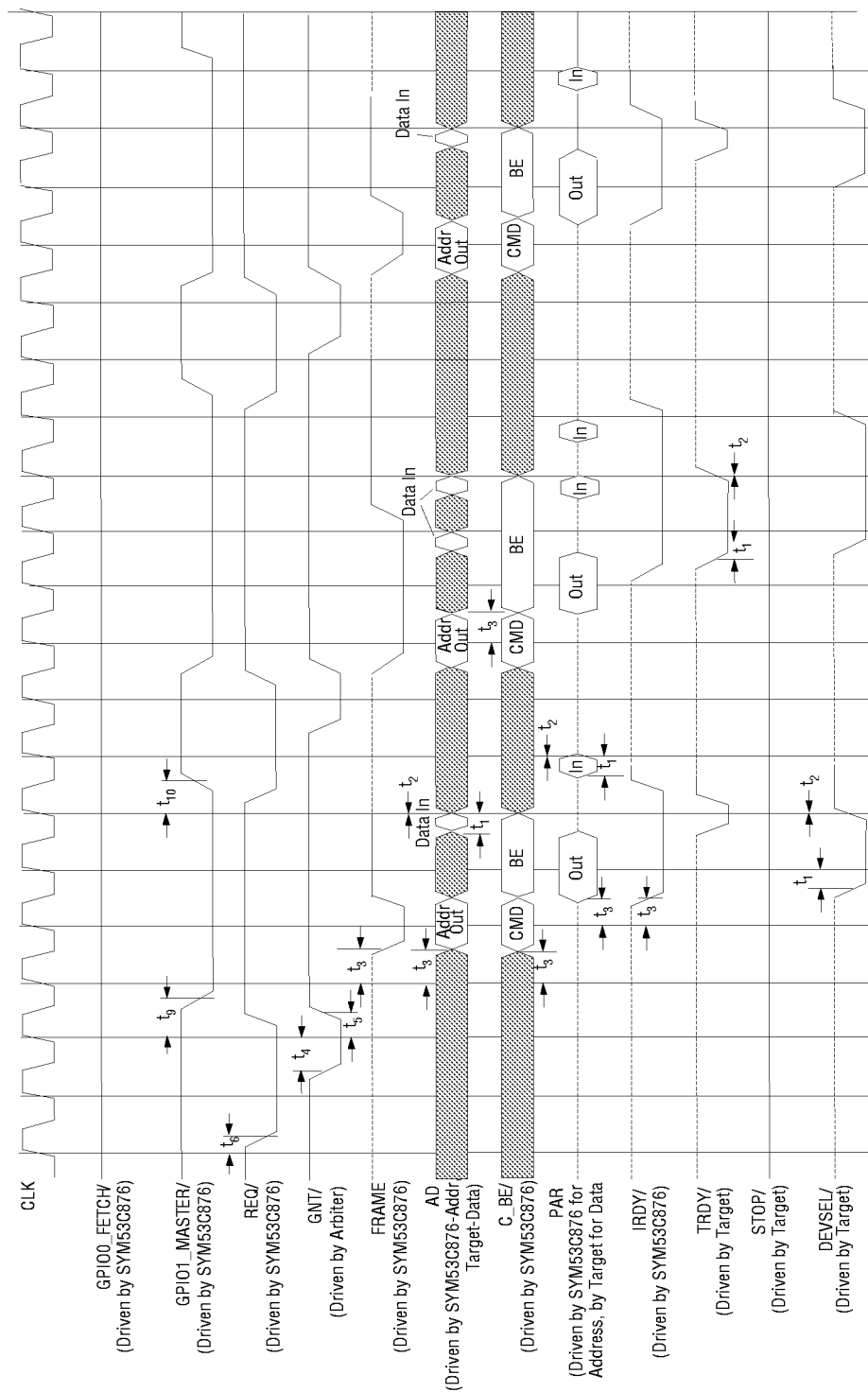

Figure 6-19: Burst Read

**Table 6-35: Burst Write**

Symbol	Parameter	Min	Max	Unit
t <sub>1</sub>	Shared signal input setup time	7	-	ns
t <sub>2</sub>	Shared signal input hold time	0	-	ns
t <sub>3</sub>	CLK to shared signal output valid	-	11	ns
t <sub>4</sub>	Side signal input setup time	10	-	ns
t <sub>5</sub>	Side signal input hold time	0	-	ns
t <sub>6</sub>	CLK to side signal output valid	-	12	ns
t <sub>9</sub>	CLK high to MASTER/ low	-	20	ns
t <sub>10</sub>	CLK high to MASTER/ high	-	20	ns

*See Note on page 6-15 regarding 3.3 Volt PCI timing changes.*

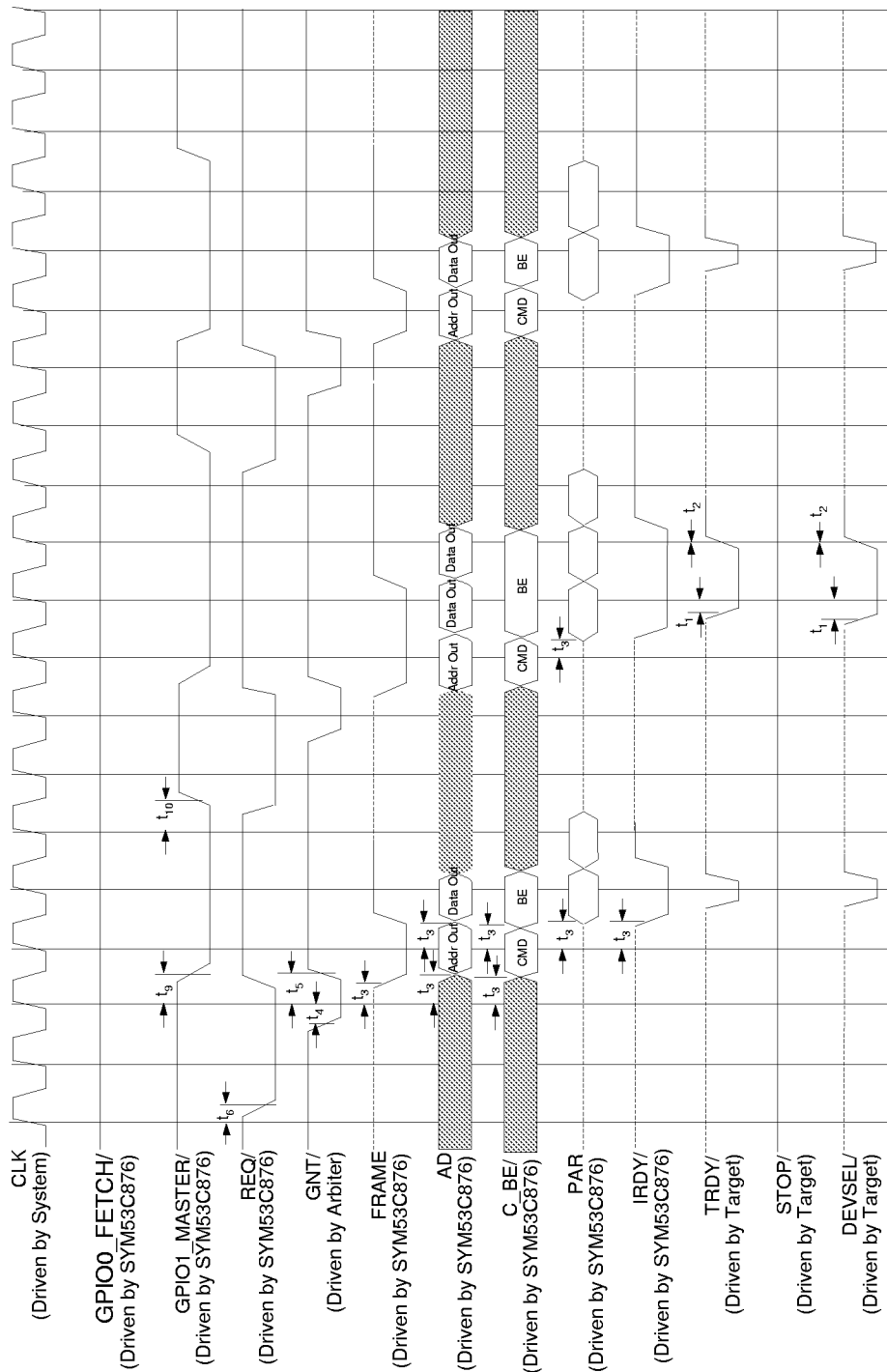

Figure 6-20: Burst Write

**Table 6-36: Read Cycle, Normal/Fast Memory ( $\geq 128$  KB), single byte access**

<b>Symbol</b>	<b>Parameter</b>	<b>Min</b>	<b>Max</b>	<b>Unit</b>
t <sub>11</sub>	Address setup to MAS/ high	25	-	ns
t <sub>12</sub>	Address hold from MAS/ high	15	-	ns
t <sub>13</sub>	MAS/ pulse width	25	-	ns
t <sub>14</sub>	MCE/ low to data clocked in	160	-	ns
t <sub>15</sub>	Address valid to data clocked in	205	-	ns
t <sub>16</sub>	MOE/ low to data clocked in	100	-	ns
t <sub>17</sub>	Data hold from address, MOE/, MCE/ change	0	-	ns
t <sub>18</sub>	Address out from MOE/, MCE/ high	50	-	ns
t <sub>19</sub>	Data setup to CLK high	5	-	ns

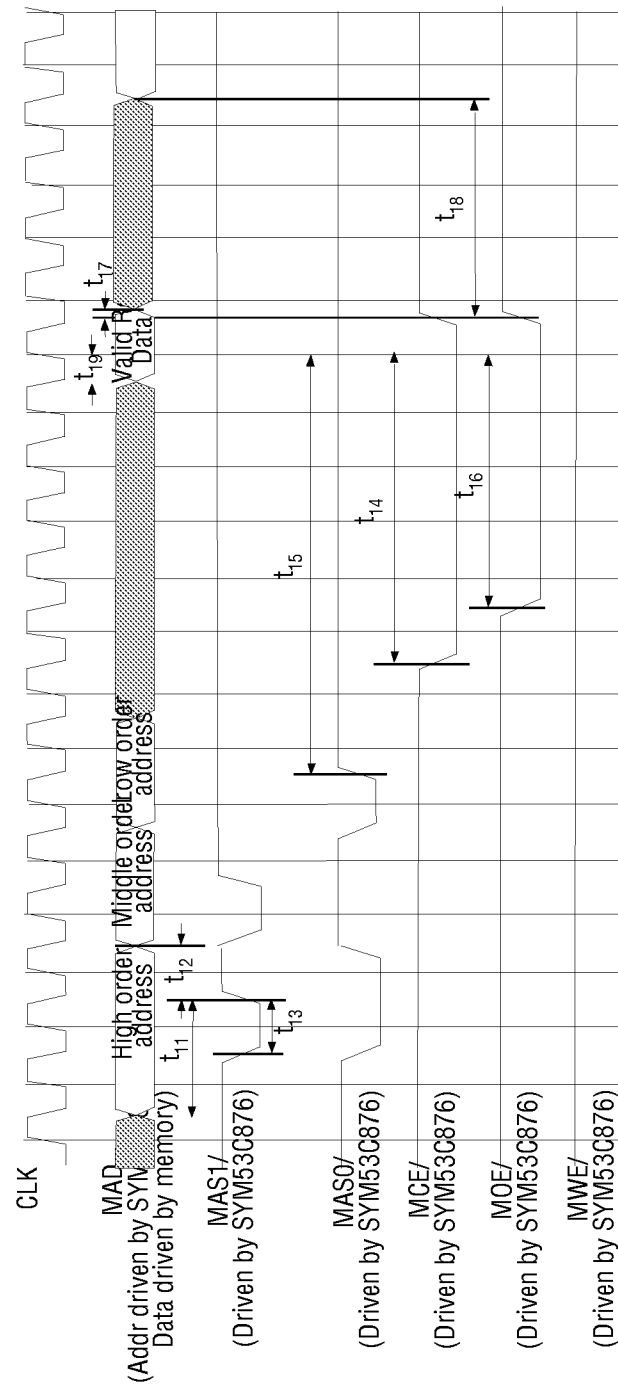

Figure 6-21: Read Cycle, Normal/Fast Memory ( $\geq 128$  KB), single byte access

**Table 6-37: Write Cycle, Normal/Fast Memory ( $\geq 128$  KB), single byte access**

<b>Symbol</b>	<b>Parameter</b>	<b>Min</b>	<b>Max</b>	<b>Unit</b>
t <sub>11</sub>	Address setup to MAS/ high	25	-	ns
t <sub>12</sub>	Address hold from MAS/ high	15	-	ns
t <sub>13</sub>	MAS/ pulse width	25	-	ns
t <sub>20</sub>	Data setup to MWE/ low	30	-	ns
t <sub>21</sub>	Data hold from MWE/ high	20	-	ns
t <sub>22</sub>	MWE/ pulse width	100	-	ns
t <sub>23</sub>	Address setup to MWE/ low	75	-	ns
t <sub>24</sub>	MCE/ low to MWE/ high	120	-	ns
t <sub>25</sub>	MCE/ low to MWE/ low	25	-	ns
t <sub>26</sub>	MWE/ high to MCE/ high	25	-	ns

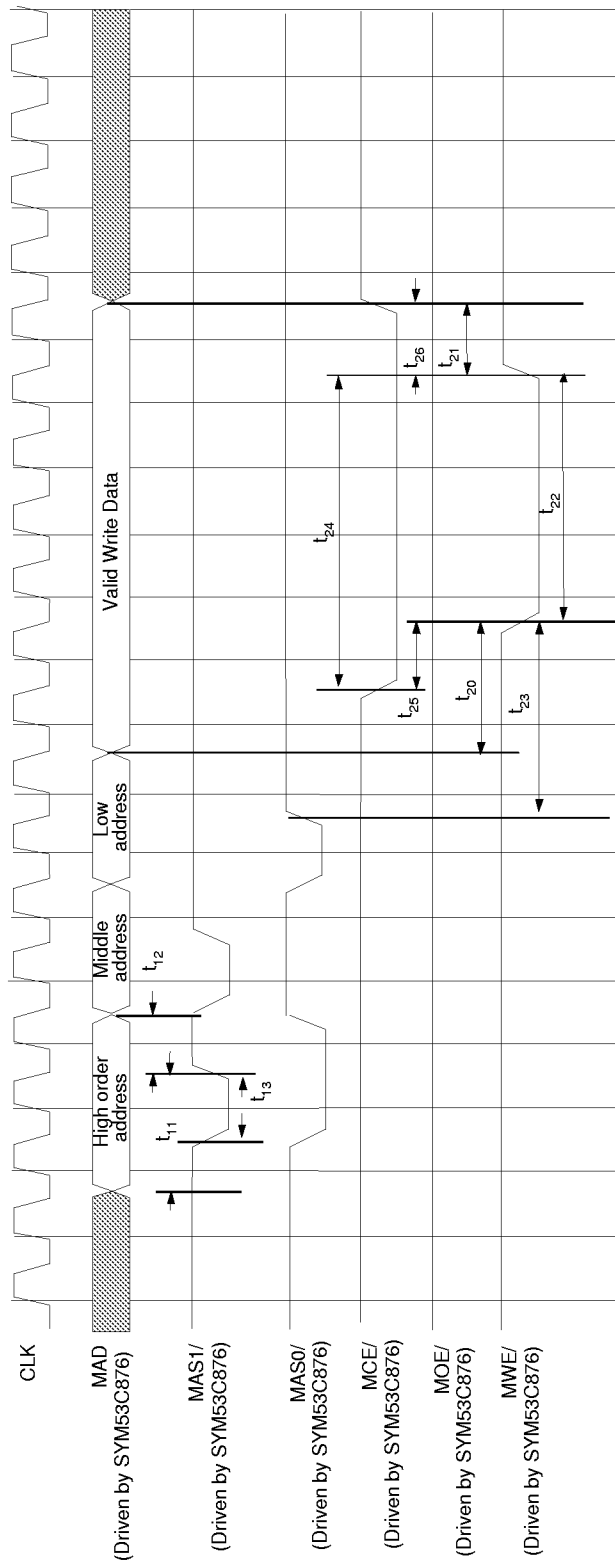
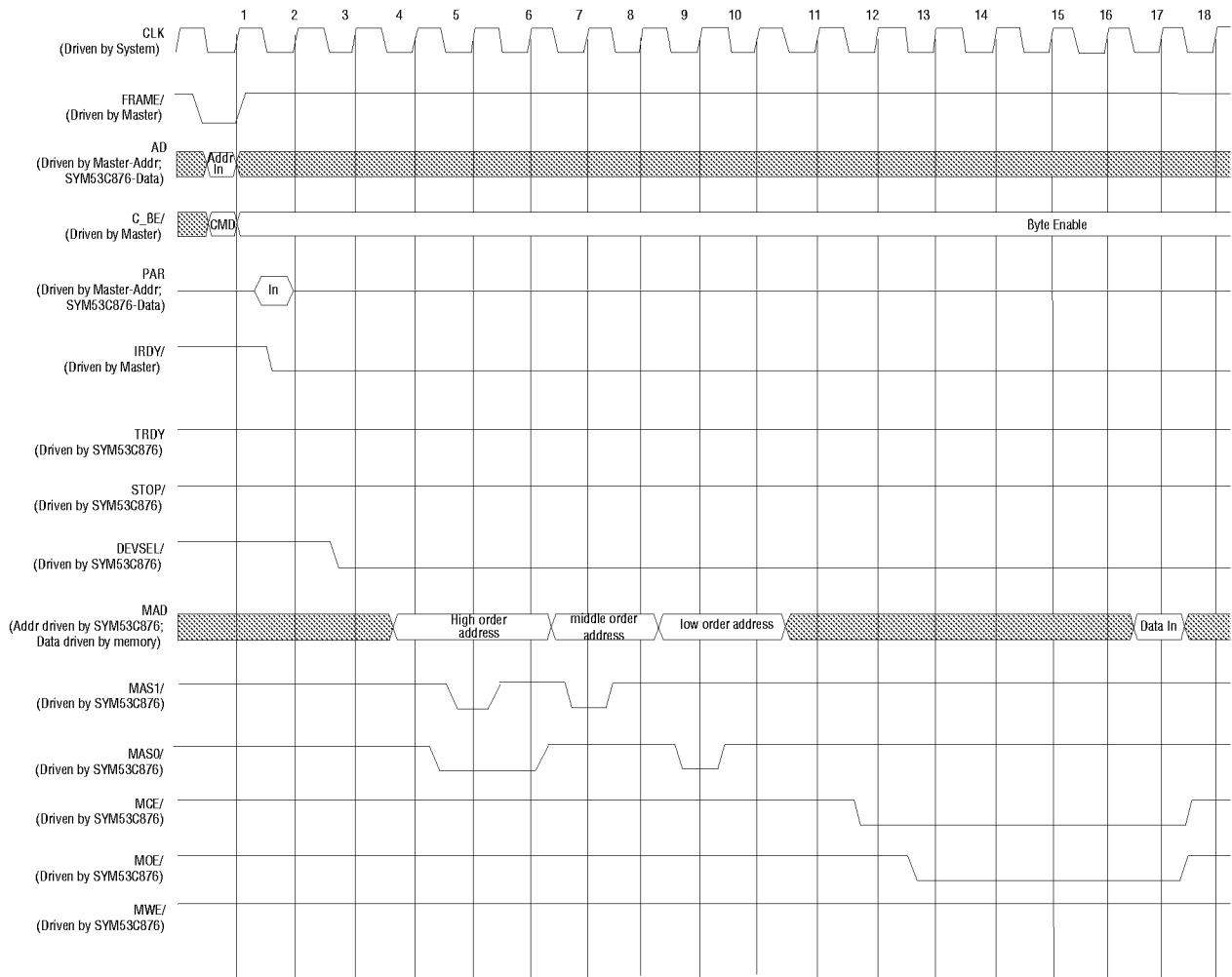
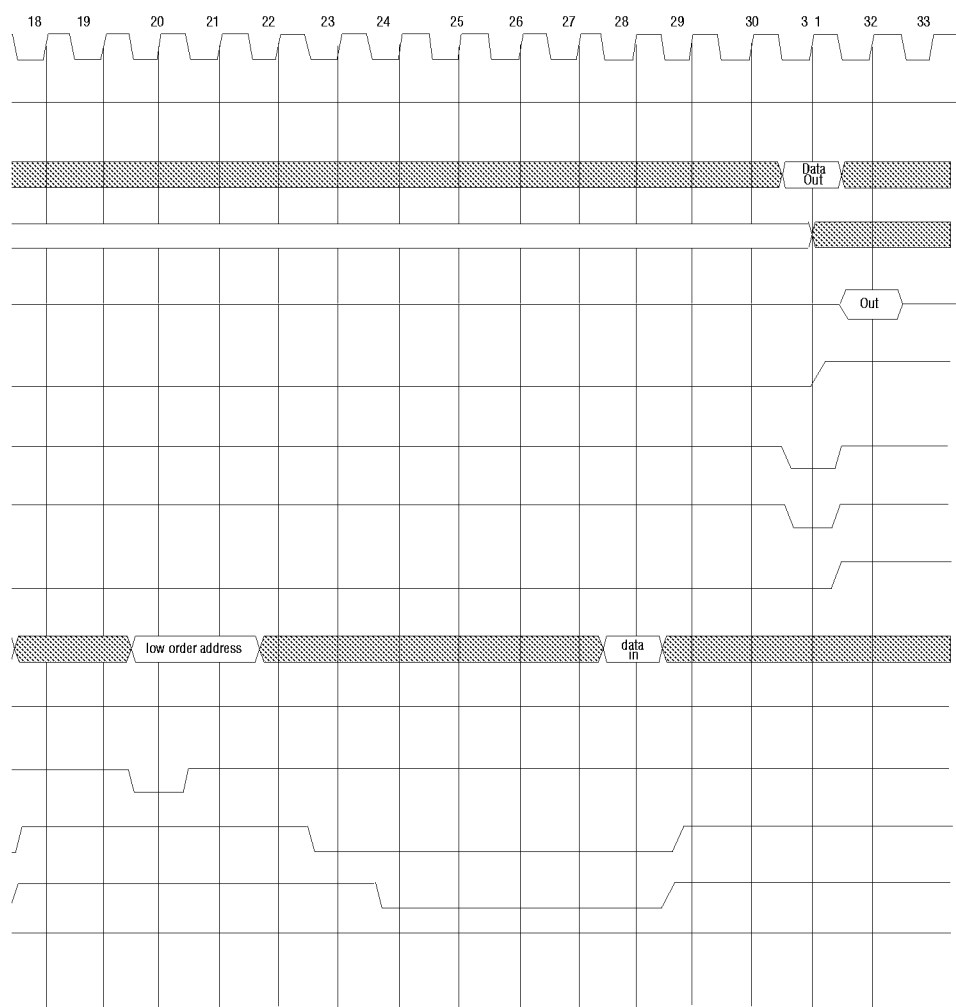

Figure 6-22: Write Cycle, Normal/Fast Memory ( $\geq 128$  KB), single byte access

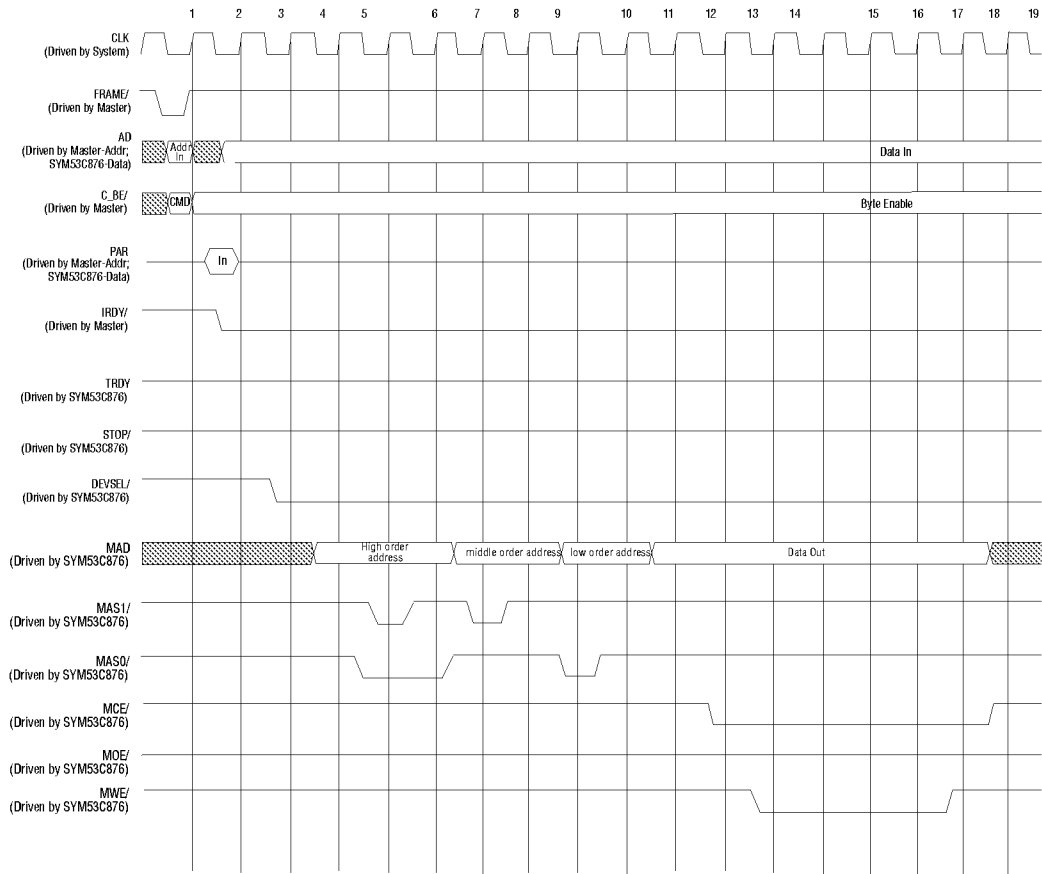

**Figure 6-23: Read Cycle, Normal/Fast Memory ( $\geq 128$  KB), multiple byte access**

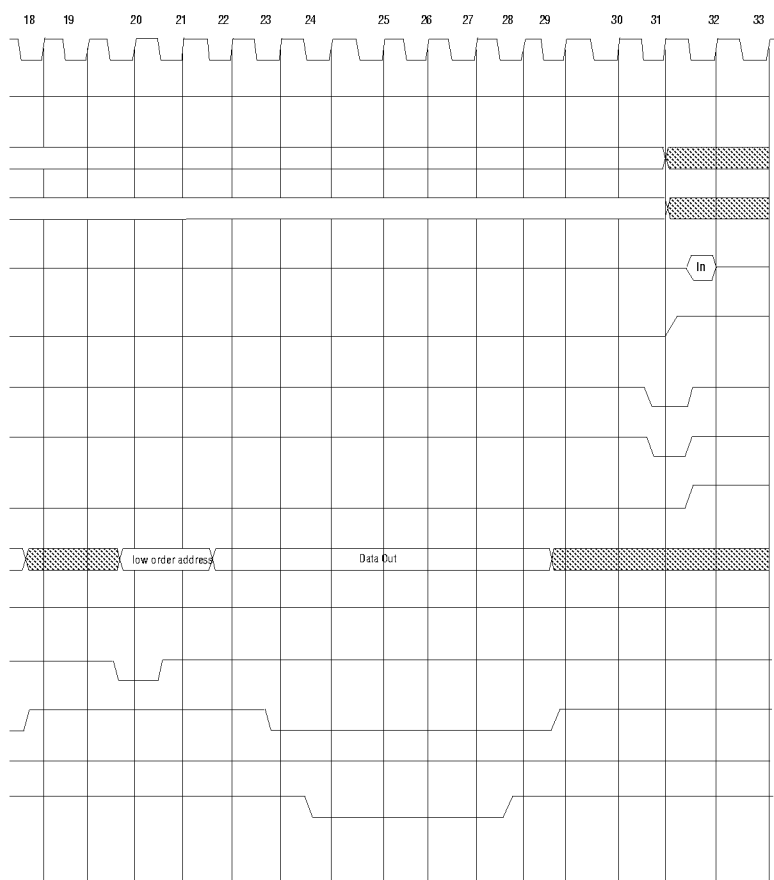



**Figure 6-23: Read Cycle, Normal/Fast Memory ( $\geq 128$  KB), multiple byte access (continued)**



**Figure 6-24: Write Cycle, Normal/Fast Memory ( $\geq 128$  KB), multiple byte access**



**Figure 6-24: Write Cycle, Normal/Fast Memory ( $\geq 128$  KB), multiple byte access (continued)**

**Table 6-38: Read Cycle, Slow Memory ( $\geq 128$  KB)**

<b>Symbol</b>	<b>Parameter</b>	<b>Min</b>	<b>Max</b>	<b>Unit</b>
t <sub>11</sub>	Address setup to MAS/ high	25	-	ns
t <sub>12</sub>	Address hold from MAS/ high	15	-	ns
t <sub>13</sub>	MAS/ pulse width	25	-	ns
t <sub>14</sub>	MCE/ low to data clocked in	160	-	ns
t <sub>15</sub>	Address valid to data clocked in	205	-	ns
t <sub>16</sub>	MOE/ low to data clocked in	100	-	ns
t <sub>17</sub>	Data hold from address, MOE/, MCE/ change	0	-	ns
t <sub>18</sub>	Address out from MOE/, MCE/ high	50	-	ns
t <sub>19</sub>	Data setup to CLK high	5	-	ns

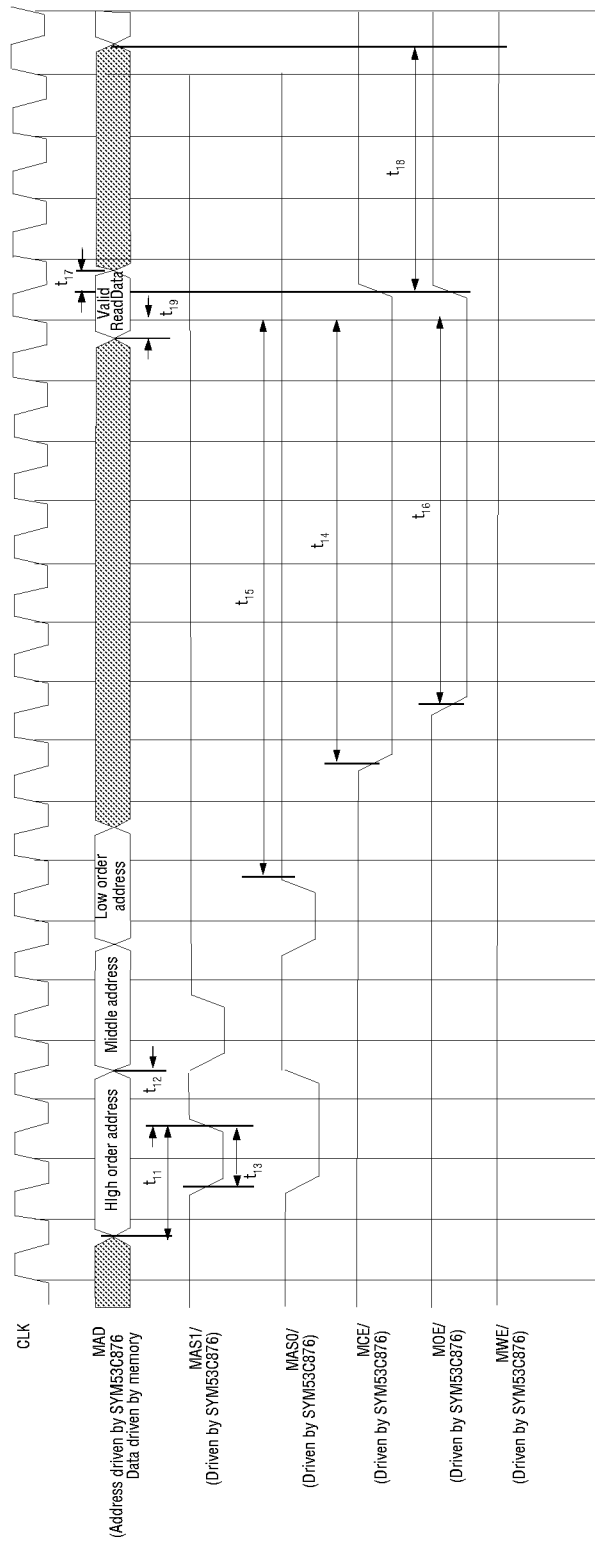
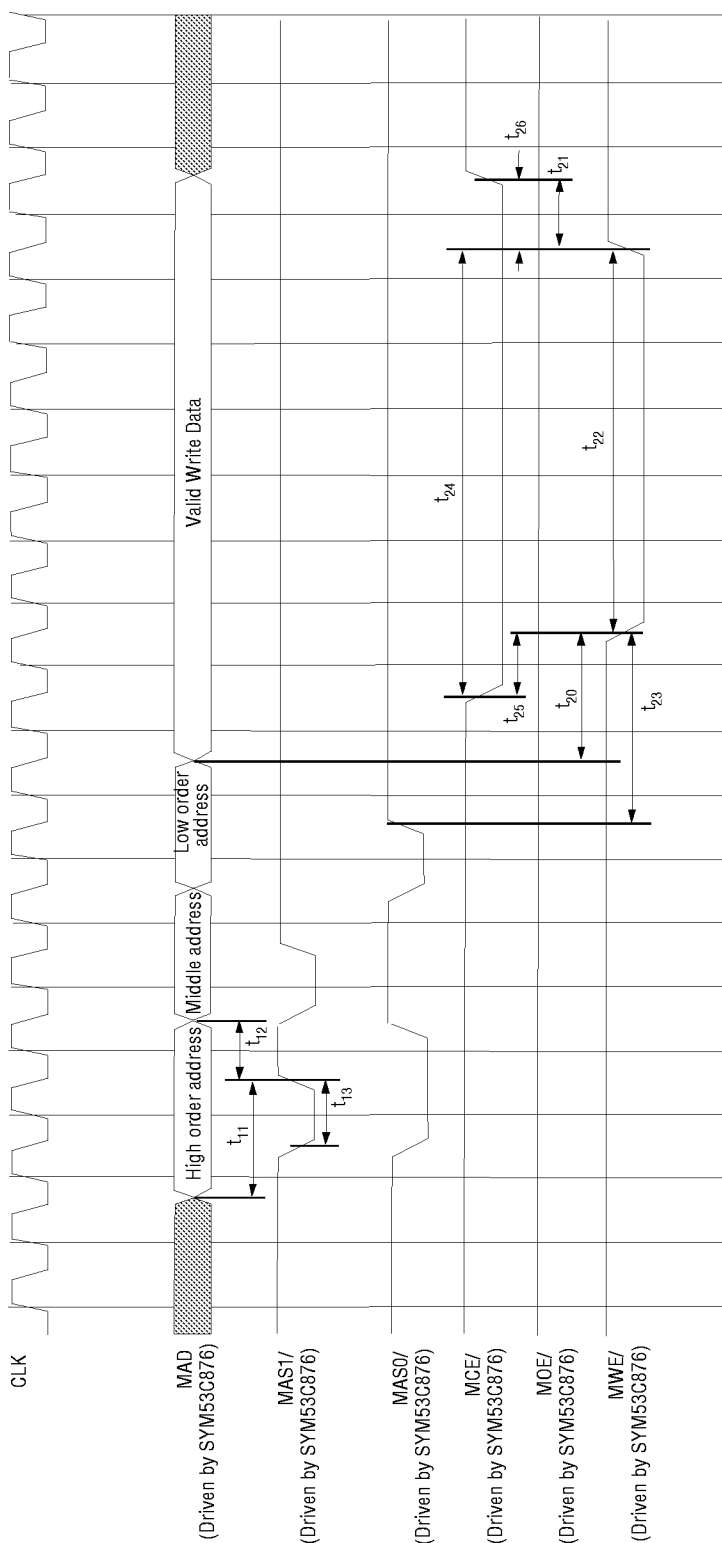

Figure 6-25: Read Cycle, Slow Memory ( $\geq 128$  KB)

**Table 6-39: Write Cycle, Slow Memory ( $\geq 128$  KB)**

<b>Symbol</b>	<b>Parameter</b>	<b>Min</b>	<b>Max</b>	<b>Unit</b>
t <sub>11</sub>	Address setup to MAS/ high	25	-	ns
t <sub>12</sub>	Address hold from MAS/ high	15	-	ns
t <sub>13</sub>	MAS/ pulse width	25	-	ns
t <sub>20</sub>	Data setup to MWE/ low	30	-	ns
t <sub>21</sub>	Data hold from MWE/ high	20	-	ns
t <sub>22</sub>	MWE/ pulse width	100	-	ns
t <sub>23</sub>	Address setup to MWE/ low	75	-	ns
t <sub>24</sub>	MCE/ low to MWE/ high	120	-	ns
t <sub>25</sub>	MCE/ low to MWE/ low	25	-	ns
t <sub>26</sub>	MWE/ high to MCE/ high	25	-	ns



**Figure 6-26: Write Cycle, Slow Memory (≥128 KB)**

**Table 6-40: Read Cycle, 16 KB ROM**

<b>Symbol</b>	<b>Parameter</b>	<b>Min</b>	<b>Max</b>	<b>Unit</b>
t <sub>11</sub>	Address setup to MAS/ high	25	-	ns
t <sub>12</sub>	Address hold from MAS/ high	15	-	ns
t <sub>13</sub>	MAS/ pulse width	25	-	ns
t <sub>14</sub>	MCE/ low to data clocked in	160	-	ns
t <sub>15</sub>	Address valid to data clocked in	205	-	ns
t <sub>16</sub>	MOE/ low to data clocked in	100	-	ns
t <sub>17</sub>	Data hold from address, MOE/, MCE/ change	0	-	ns
t <sub>18</sub>	Address out from MOE/, MCE/ high	50	-	ns
t <sub>19</sub>	Data setup to CLK high	5	-	ns



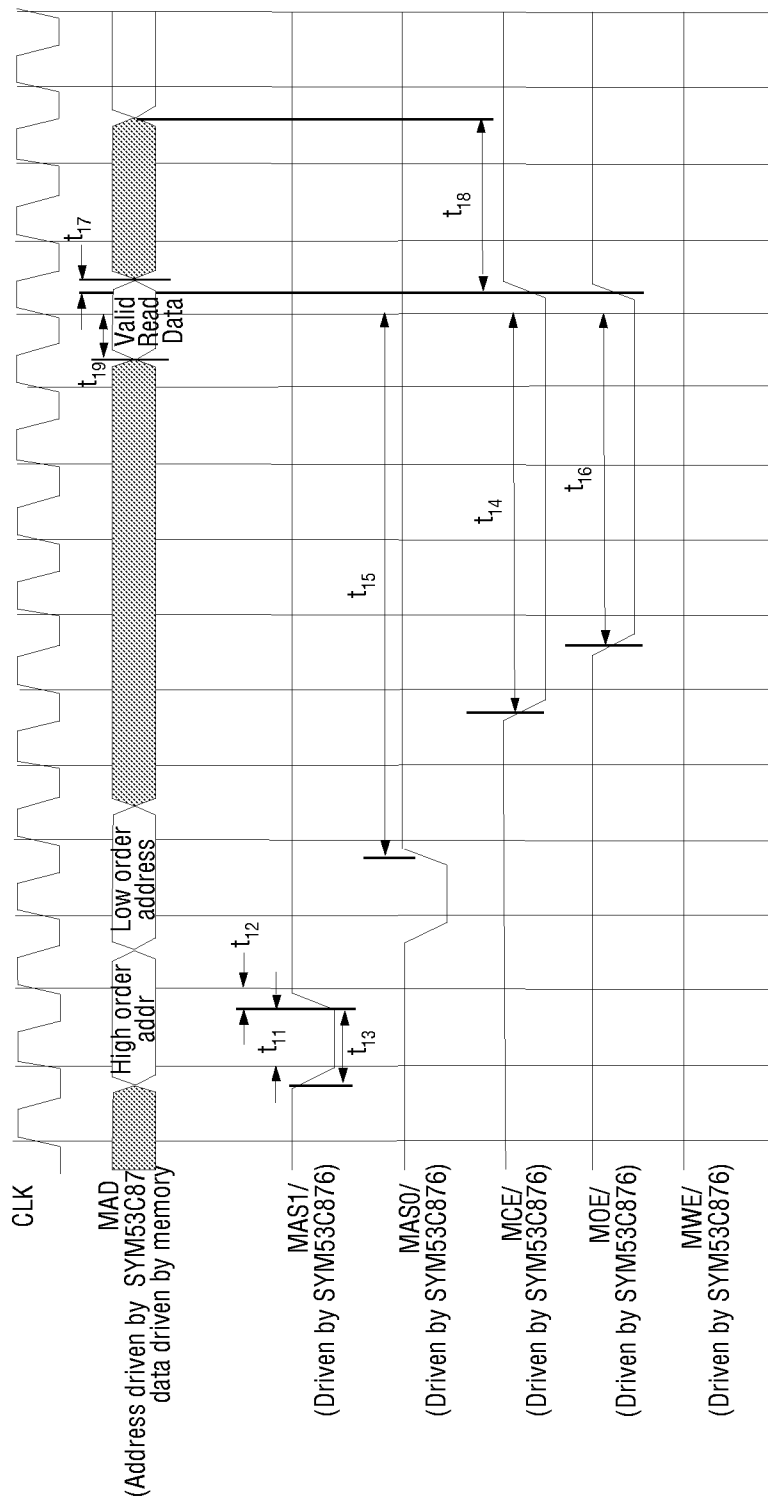

Figure 6-27: Read Cycle, 16 KB ROM

**Table 6-41: Write Cycle, 16 KB ROM**

<b>Symbol</b>	<b>Parameter</b>	<b>Min</b>	<b>Max</b>	<b>Unit</b>
t <sub>11</sub>	Address setup to MAS/ high	25	-	ns
t <sub>12</sub>	Address hold from MAS/ high	15	-	ns
t <sub>13</sub>	MAS/ pulse width	25	-	ns
t <sub>20</sub>	Data setup to MWE/ low	30	-	ns
t <sub>21</sub>	Data hold from MWE/ high	20	-	ns
t <sub>22</sub>	MWE/ pulse width	100	-	ns
t <sub>23</sub>	Address setup to MWE/ low	75	-	ns
t <sub>24</sub>	MCE/low to MWE/ high	120	-	ns
t <sub>25</sub>	MCE/low to MWE/ low	25	-	ns
t <sub>26</sub>	MWE/high to MCE/ high	25		

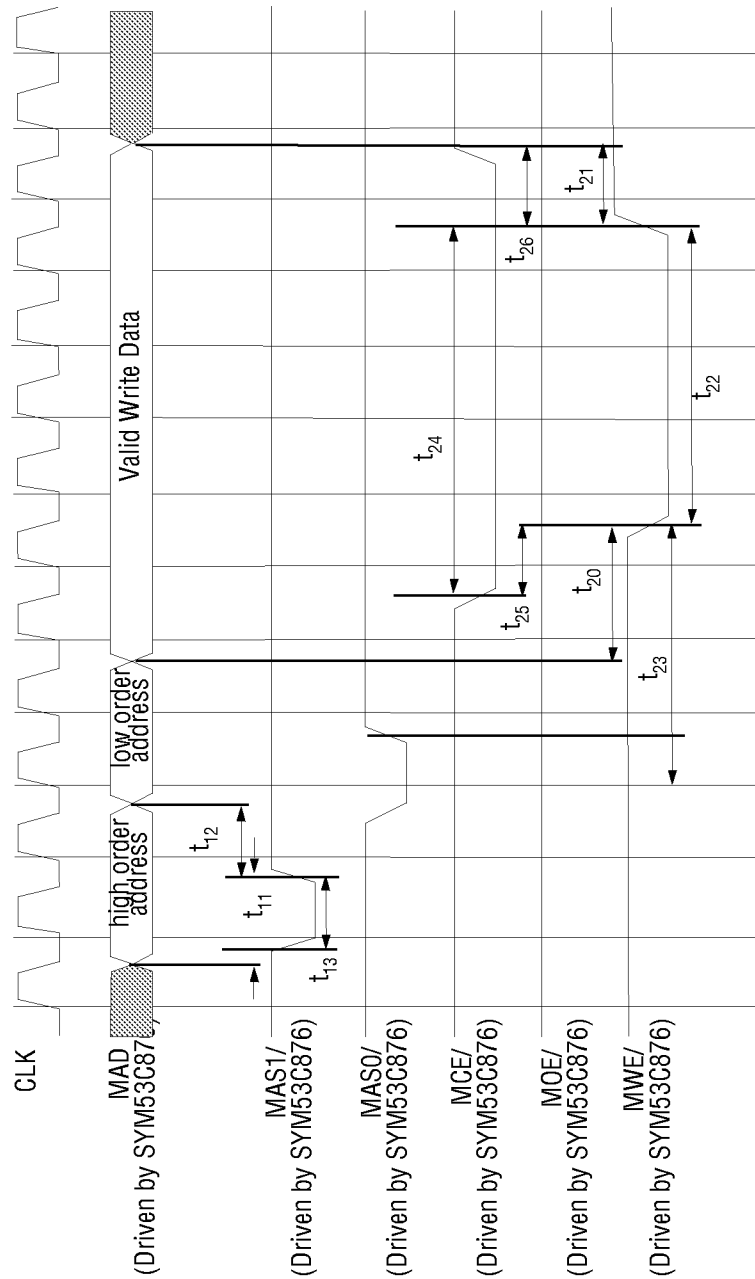

Figure 6-28: Write Cycle, 16 KB ROM

## PCI and External Memory Interface Timings

**Table 6-42: SYM53C876 PCI and External Memory Interface Timings**

Symbol	Parameter	Min	Max	Unit
t <sub>1</sub>	Shared signal input setup time	7	-	ns
t <sub>2</sub>	Shared signal input hold time	0	-	ns
t <sub>3</sub>	CLK to shared signal output valid	-	11	ns
t <sub>4</sub>	Side signal input setup time	10	-	ns
t <sub>5</sub>	Side signal input hold time	0	-	ns
t <sub>6</sub>	CLK to side signal output valid	-	12	ns
t <sub>7</sub>	CLK high to FETCH/low	-	20	ns
t <sub>8</sub>	CLK high to FETCH/high	-	20	ns
t <sub>9</sub>	CLK high to MASTER/ low	-	20	ns
t <sub>10</sub>	CLK high to MASTER/ high	-	20	ns
t <sub>11</sub>	Address setup to MAS/ high	25	-	ns
t <sub>12</sub>	Address hold from MAS/ high	15	-	ns
t <sub>13</sub>	MAS/ pulse width	25	-	ns
t <sub>14</sub>	MCE/ low to data clocked in	160	-	ns
t <sub>15</sub>	Address valid to data clocked in	205	-	ns
t <sub>16</sub>	MOE/ low to data clocked in	100	-	ns
t <sub>17</sub>	Data hold from address, MOE/, MCE/ change	0	-	ns
t <sub>18</sub>	Address out from MOE/, MCE/ high	50	-	ns
t <sub>19</sub>	Data setup to CLK high	5	-	ns
t <sub>20</sub>	Data setup to MWE/ low	30	-	ns
t <sub>21</sub>	Data hold from MWE/ high	20	-	ns
t <sub>22</sub>	MWE/ pulse width	100	-	ns
t <sub>23</sub>	Address setup to MWE/ low	75	-	ns
t <sub>24</sub>	MCE/ low to MWE/ high	120	-	ns
t <sub>25</sub>	MCE/ low to MWE/ low	25	-	ns
t <sub>26</sub>	MWE/ high to MCE/high	25	-	ns

## SCSI Interface Timings

**Table 6-43: Initiator Asynchronous Send**

Symbol	Parameter	Min	Max	Units
$t_1$	SACK/ asserted from SREQ/ asserted	5	-	ns
$t_2$	SACK/ deasserted from SREQ/ deasserted	5	-	ns
$t_3$	Data setup to SACK/ asserted	55	-	ns
$t_4$	Data hold from SREQ/ deasserted	20	-	ns

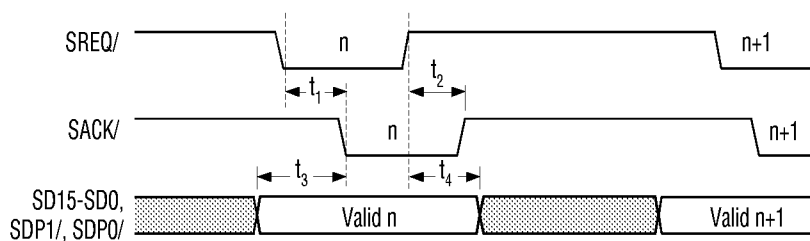

**Figure 6-29: Initiator Asynchronous Send**

**Table 6-44: Initiator Asynchronous Receive**

Symbol	Parameter	Min	Max	Units
$t_1$	SACK/ asserted from SREQ/ asserted	5	-	ns
$t_2$	SACK/ deasserted from SREQ/ deasserted	5	-	ns
$t_3$	Data setup to SREQ/ asserted	0	-	ns
$t_4$	Data hold from SACK/ asserted	0	-	ns

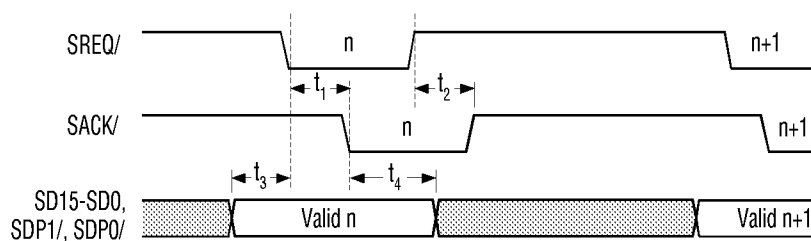

**Figure 6-30: Initiator Asynchronous Receive**

**Table 6-45: Target Asynchronous Send**

Symbol	Parameter	Min	Max	Units
$t_1$	SREQ/ deasserted from SACK/ asserted	5	-	ns
$t_2$	SREQ/ asserted from SACK/ deasserted	5	-	ns
$t_3$	Data setup to SREQ/ asserted	55	-	ns
$t_4$	Data hold from SACK/ asserted	20	-	ns

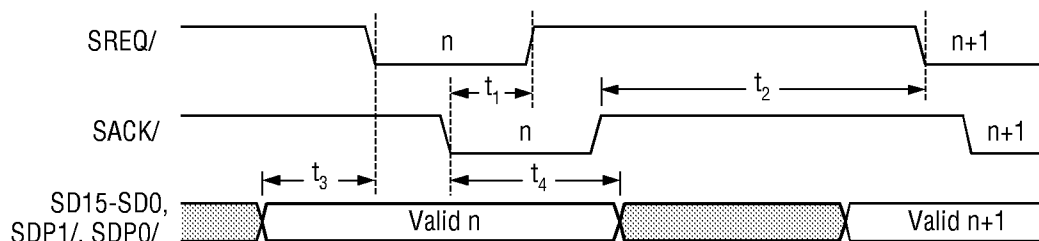

**Figure 6-31: Target Asynchronous Send**

**Table 6-46: Target Asynchronous Receive**

Symbol	Parameter	Min	Max	Units
$t_1$	SREQ/ deasserted from SACK/ asserted	5	-	ns
$t_2$	SREQ/ asserted from SACK/ deasserted	5	-	ns
$t_3$	Data setup to SACK/ asserted	0	-	ns
$t_4$	Data hold from SREQ/ deasserted	0	-	ns

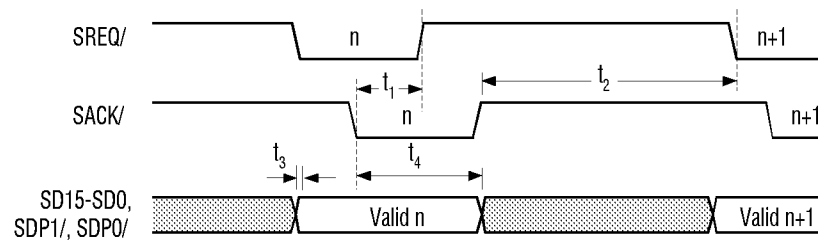

**Figure 6-32: Target Asynchronous Receive**

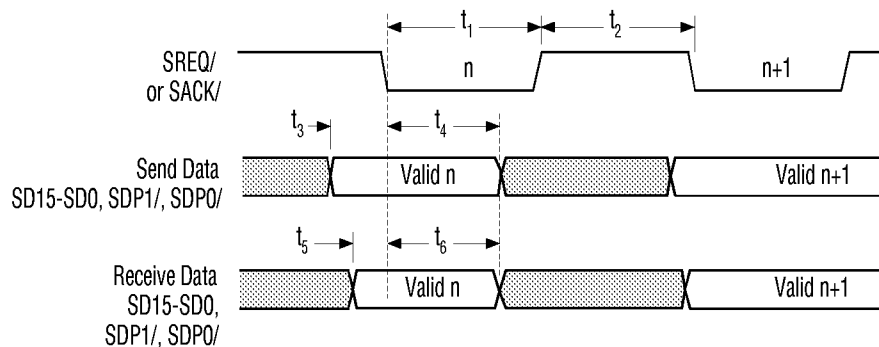

**Figure 6-33: Initiator and Target Synchronous Transfers**

**Table 6-47: SCSI-1 transfers (Single-Ended, 5.0 MB/s)**

Symbol	Parameter	Min	Max	Units
$t_1$	Send SREQ/ or SACK/ assertion pulse width	90	-	ns
$t_2$	Send SREQ/ or SACK/ deassertion pulse width	90	-	ns

**Table 6-47: SCSI-1 transfers (Single-Ended, 5.0 MB/s)**

<b>Symbol</b>	<b>Parameter</b>	<b>Min</b>	<b>Max</b>	<b>Units</b>
t <sub>1</sub>	Receive SREQ/ or SACK/ assertion pulse width	90	-	ns
t <sub>2</sub>	Receive SREQ/ or SACK/ deassertion pulse width	90	-	ns
t <sub>3</sub>	Send data setup to SREQ/ or SACK/ asserted	55	-	ns
t <sub>4</sub>	Send data hold from SREQ/ or SACK/ asserted	100	-	ns
t <sub>5</sub>	Receive data setup to SREQ/ or SACK/ asserted	0	-	ns
t <sub>6</sub>	Receive data hold from SREQ/ or SACK/ asserted	45	-	ns



**Table 6-48: SCSI-2 Fast Transfers (10.0 MB/s (8-bit transfers) or 20.0 MB/s (16-bit transfers), 40 MHz clock)**

Symbol	Parameter	Min	Max	Units
t <sub>1</sub>	Send SREQ/ or SACK/ assertion pulse width	35	-	ns
t <sub>2</sub>	Send SREQ/ or SACK/ deassertion pulse width	35	-	ns
t <sub>1</sub>	Receive SREQ/ or SACK/ assertion pulse width	20	-	ns
t <sub>2</sub>	Receive SREQ/ or SACK/ deassertion pulse width	20	-	ns
t <sub>3</sub>	Send data setup to SREQ/ or SACK/ asserted	33	-	ns
t <sub>4</sub>	Send data hold from SREQ/ or SACK/ asserted	45	-	ns
t <sub>5</sub>	Receive data setup to SREQ/ or SACK/ asserted	0	-	ns
t <sub>6</sub>	Receive data hold from SREQ/ or SACK/ asserted	10	-	ns

**Table 6-49: SCSI-2 Fast-20 Single-Ended Transfers (20.0 MB/s (8-bit transfers) or 40.0 MB/s (16-bit transfers), 80 MHz clock) with clock doubled internally**

Symbol	Parameter	Min	Max	Unit
t <sub>1</sub>	Send SREQ/ or SACK/ assertion pulse width	16	-	ns
t <sub>2</sub>	Send SREQ/ or SACK/ deassertion pulse width	16	-	ns
t <sub>1</sub>	Receive SREQ/ or SACK/ assertion pulse width	10	-	ns
t <sub>2</sub>	Receive SREQ/ or SACK/ deassertion pulse width	10	-	ns
t <sub>3</sub>	Send data setup to SREQ/ or SACK/ asserted	12	-	ns
t <sub>4</sub>	Send data hold from SREQ/ or SACK/ asserted	17	-	ns
t <sub>5</sub>	Receive data setup to SREQ/ or SACK/ asserted	0	-	ns
t <sub>6</sub>	Receive data hold from SREQ/ or SACK/ asserted	6	-	ns



## Appendix A Register Summary

### Configuration Registers

#### Register 00h

Vendor ID

*Read Only*

VID	VID	VID	VID
15-12	11-8	7-4	3-0

Default >>>

1            0            0            0

#### Register 02h

Device ID

*Read Only*

DID	DID	DID	DID
15-12	11-8	7-4	3-0

Default >>>

0            0            0            F

#### Register 04h

Command

*Read/Write*

RES	SE	RES	EPER	RES	WIE	RES	EBM	EMS	EIS
15-9	8	7	6	5	4	3	2	1	0

Default >>>

0    0    0    0    0    0    0    0    0    0

- Bits 15-9    Reserved
- Bit 8        SERR/ Enable(SE)
- Bit 7        Reserved
- Bit 6        Enable Parity Error Response (EPER)
- Bit 5        Reserved
- Bit 4        Write and Invalidate Enable (WIE)
- Bit 3        Reserved
- Bit 2        Enable Bus Mastering (EBM)
- Bit 1        Enable Memory Space (EMS)
- Bit 0        Enable I/O Space (EIS)

#### Register 06h

Status

*Read/Write*

DPE	SSE	RMA	RTA	RES	DT	DPR	RES	NC	RES
15	14	13	12	11	10-9	8	7-5	4	3-0

Default >>>

0    0    0    0    0    0    0    0    0    0

- Bit 15      Detected Parity Error (DPE)  
(from Slave)
- Bit 14      Signaled System Error (SSE)
- Bit 13      Received Master Abort (RMA)  
(from Master)
- Bit 12      Received Target Abort (RTA)  
(from Master)
- Bit 11      Reserved
- Bits 10-9   DEVSEL/ Timing (DT)
- Bit 8        Data Parity Reported(DPR)
- Bits 7-5    Reserved
- Bit 4        New Capabilities (NC)
- Bit 3-0     Reserved

#### Register 08h

Revision ID

*Read Only*

RID	RID	RID	RID	RID	RID	RID	RID
7	6	5	4	3	2	1	0

Default >>>

0    0    1    1    0    1    1    1

#### Register 09h

Class Code

*Read Only*

CC	CC	CC	CC	CC	CC
23-20	19-16	15-12	11-8	7-4	3-0

Default >>>

0            1            0            0            0            0

Register Summary  
**Configuration Registers**

**Register 0Ch**  
**Cache Line Size**  
*Read/Write*

CLS 7	CLS 6	CLS 5	CLS 4	CLS 3	CLS 2	CLS 1	CLS 0
Default >>>							
0	0	0	0	0	0	0	0

**Register 0Dh**  
**Latency Timer**  
*Read/Write*

LT 7	LT 6	LT 5	LT 4	LT 3	LT 2	LT 1	LT 0
Default >>>							
0	0	0	0	0	0	0	0

**Register 0Eh**  
**Header Type**  
*Read Only*

HT 7-4	HT 3-0
Default >>>	
8	0

**Register 0Fh**  
**BIST**  
*Read Only*

BIST Capable 7	Start BIST 6	RES 5-4	Completion Code 3-0
Default >>>			
0	0	00	0000

**Register 10h**  
**Base Address Zero (I/O)**  
*Read/Write*

BAZ 31-28	BAZ 27-24	BAZ 23-20	BAZ 19-16	BAZ 15-12	BAZ 11-8	BAZ 7-4	BAZ 3-0
Default >>>							
x	x	x	x	x	x	x	xxx1

**Register 14h**  
**Base Address One (Memory)**  
*Read/Write*

BAO 31-28	BAO 27-24	BAO 23-20	BAO 19-16	BAO 15-12	BAO 11-8	BAO 7-4	BAO 3-0
Default >>>							
X	X	X	X	X	X	X	XXX0

**Register 18h**  
**Base Address Two (Memory)**  
*Read/Write*

BAT 31-28	BAT 27-24	BAT 23-20	BAT 19-16	BAT 15-12	BAT 11-8	BAT 7-4	BAT 3-0
Default >>>							
X	X	X	X	X	X	X	XXX0

**Register 2Ch**  
**Subsystem Vendor ID**  
*Read Only*

SVID 15-12	SVID 11-8	SVID 7-4	SVID 3-0
If EEPROM not enabled <<<Default>>> Mode A			
0	0	0	0
If EEPROM not enabled <<<Default>>> Mode D			
1	0	0	0
EEPROM value if EEPROM enabled <<<Default>>>			
X	X	X	X

**Register 2Eh**  
**Subsystem ID**  
*Read Only*

SID 15-12	SID 11-8	SID 7-4	SID 3-0
If EEPROM not enabled <<<Default>>> Mode A			
0	0	0	0
If EEPROM not enabled <<<Default>>> Mode D			
1	0	0	0
EEPROM value if EEPROM enabled <<<Default>>>			
X	X	X	X

**Register 30h**  
**Expansion ROM Base Address**  
*Read/Write*

ERBA 31-28	ERBA 27-24	ERBA 23-20	ERBA 19-16	ERBA 15-12	ERBA 11-8	ERBA 7-4	ERBA 3-0
Default >>>							
0	0	0	0	0	0	0	0

**Register 34h**  
**Capabilities Pointer**  
*Read Only*

CP 7	CP 6	CP 5	CP 4	CP 3	CP 2	CP 1	CP 0
Default >>>							
0	1	0	0	0	0	0	0

**Register 3Ch**  
Interrupt Line  
*Read/Write*

IL	IL	IL	IL	IL	IL	IL	IL
7	6	5	4	3	2	1	0
Default >>>							
0	0	0	0	0	0	0	0

**Register 3Dh**  
Interrupt Pin  
*Read Only*

IP	IP	IP	IP	IP	IP	IP	IP
7	6	5	4	3	2	1	0
SCSI Function A <<<Default >>>							
0	0	0	0	0	0	0	1
SCSI Function B if MAD(4) pulled low <<<Default >>>							
0	0	0	0	0	0	0	1
SCSI Function B if MAD(4) not pulled low <<<Default >>>							
0	0	0	0	0	0	1	0

**Register 3Eh**  
Min\_Gnt  
*Read Only*

MG	MG	MG	MG	MG	MG	MG	MG
7	6	5	4	3	2	1	0
Default >>>							
0	0	0	1	0	0	0	1

**Register 3Fh**  
Max\_Lat  
*Read Only*

ML	ML	ML	ML	ML	ML	ML	ML
7	6	5	4	3	2	1	0
Default >>>							
0	1	0	0	0	0	0	0

**Register 40h**  
Capability ID  
*Read Only*

CID	CID	CID	CID	CID	CID	CID	CID
7	6	5	4	3	2	1	0
Default >>>							
0	0	0	0	0	0	0	0

**Register 41h**  
Next Item Pointer  
*Read Only*

NP	NP	NP	NP	NP	NP	NP	NP
7	6	5	4	3	2	1	0
Default >>>							
0	0	0	0	0	0	0	0

**Register 42h**  
Power Management Capabilities  
*Read Only*

PMES	D2S	D1S	RES	DSI	APS	PMEC	VER
15-11	10	9	8-6	5	4	3	2-0
Default >>>							
0	1	1	0	0	0	0	1

**Register 44h**  
Power Management Control/Status  
*Read/Write*

PST	DSCL	DSLTL	PEN	RES	PWS
15	14-13	12-9	8	7-2	1-0
Default >>>					
0	0	0	0	0	0

**Register 46h**  
PMCSR BSE  
*Read Only*

BSE	BSE	BSE	BSE	BSE	BSE	BSE	BSE
7	6	5	4	3	2	1	0
Default >>>							
0	0	0	0	0	0	0	0

## SCSI Registers

### Register 00h SCSI Control Zero (SCNTL0) Read/Write

ARB1	ARB0	START	WATN	EPC	RES	AAP	TRG
7	6	5	4	3	2	1	0

Default >>>  
 1 1 0 0 0 X 0 0

- Bit 7 ARB1 (Arbitration Mode bit 1)
- Bit 6 ARB0 (Arbitration Mode bit 0)
- Bit 5 START (Start Sequence)
- Bit 4 WATN (Select with SATN/ on a Start Sequence)
- Bit 3 EPC (Enable Parity Checking)
- Bit 2 Reserved
- Bit 1 AAP (Assert SATN/ on Parity Error)
- Bit 0 TRG (Target Mode)

### Register 01h SCSI Control One (SCNTL1) Read/Write

EXC	ADB	DHP	CON	RST	AESP	IARB	SST
7	6	5	4	3	2	1	0

Default >>>  
 0 0 0 0 0 0 0 0

- Bit 7 EXC (Extra Clock Cycle of Data Setup)
- Bit 6 ADB (Assert SCSI Data Bus)
- Bit 5 DHP (Disable Halt on Parity Error or ATN) (Target Only)
- Bit 4 CON (Connected)
- Bit 3 RST (Assert SCSI RST/ Signal)
- Bit 2 AESP (Assert Even SCSI Parity (force bad parity))
- Bit 1 IARB (Immediate Arbitration)
- Bit 0 SST (Start SCSI Transfer)

**CAUTION:** Writing to this register while not connected may cause the loss of a selection/reselection by resetting the Connected bit.

### Register 02h SCSI Control Two (SCNTL2) Read/Write

SDU	CHM	SLPMD	SLPH-BEN	WSS	VUE0	VUE1	WSR
7	6	5	4	3	2	1	0

Default >>>  
 0 0 0 0 0 0 X 0

- Bit 7 SDU (SCSI Disconnect Unexpected)
- Bit 6 CHM (Chained Mode)
- Bit 5 SLPMD (SLPAR Mode Bit)
- Bit 4 SLPHBEN (SLPAR High Byte Enable)
- Bit 3 WSS (Wide SCSI Send)
- Bit 2 VUE0 (Vendor Unique Enhancement bit 0)
- Bit 1 VUE1 (Vendor Unique Enhancement bit 1)
- Bit 0 WSR (Wide SCSI Receive)

### Register 03h SCSI Control Three (SCNTL3) Read/Write

USE	SCF2	SCF1	SCF0	EWS	CCF2	CCF1	CCF0
7	6	5	4	3	2	1	0

Default >>>  
 0 0 0 0 0 0 0 0

- Bit 7 USE (Ultra SCSI Enable)
- Bits 6-4 SCF2-0 (Synchronous Clock Conversion Factor)
- Bit 3 EWS (Enable Wide SCSI)
- Bits 2-0 CCF2-0 (Clock Conversion Factor)

**Register 04h**  
**SCSI Chip ID (SCID)**  
*Read/Write*

RES	RRE	SRE	RES	ENC3	ENC2	ENC1	ENC0
7	6	5	4	3	2	1	0
Default >>>							
X	0	0	X	0	0	0	0

- Bit 7 Reserved
- Bit 6 RRE (Enable Response to Reselection)
- Bit 5 SRE (Enable Response to Selection)
- Bit 4 Reserved
- Bits 3-0 Encoded Chip SCSI ID, bits 3-0

**Register 05h**  
**SCSI Transfer (SXFER)**  
*Read/Write*

TP2	TP1	TP0	MO4	MO3	MO2	MO1	MO0
7	6	5	4	3	2	1	0
Default >>>							
0	0	0	X	0	0	0	0

- Bits 7-5 TP2-0 (SCSI Synchronous Transfer Period)
- Bits 4-0 MO4-MO0 (Max SCSI Synchronous Offset)

**Register 06h**  
**SCSI Destination ID (SDID)**  
*Read/Write*

RES	RES	RES	RES	ENC3	ENC2	ENC1	ENC0
7	6	5	4	3	2	1	0
Default >>>							
X	X	X	X	0	0	0	0

- Bits 7-4 Reserved
- Bits 3-0 Encoded Destination SCSI ID

**Register 07h**  
**General Purpose (GPREG)**  
*Read/Write*

RES	RES	RES	GPI04	GPI03	GPI02	GPI01	GPI00
7	6	5	4	3	2	1	0
Default >>>							
X	X	X	0	X	X	X	X

- Bits 7-5, 3 Reserved
- Bits 4, 2-0 GPI04-GPI00 (General Purpose)

**Register 08h**  
**SCSI First Byte Received (SFBR)**  
*Read/Write*

1B7	1B6	1B5	1B4	1B3	1B2	1B1	1B0
7	6	5	4	3	2	1	0
Default >>>							
0	0	0	0	0	0	0	0

**Register 09h**  
**SCSI Output Control Latch (SOCL)**  
*Read/Write*

REQ	ACK	BSY	SEL	ATN	MSG	C/D	I/O
7	6	5	4	3	2	1	0
Default >>>							
0	0	0	0	0	0	0	0

- Bit 7 REQ(Assert SCSI REQ/ Signal)
- Bit 6 ACK(Assert SCSI ACK/ Signal)
- Bit 5 BSY(Assert SCSI BSY/ Signal)
- Bit 4 SEL(Assert SCSI SEL/ Signal)
- Bit 3 ATN(Assert SCSI ATN/ Signal)
- Bit 2 MSG(Assert SCSI MSG/ Signal)
- Bit 1 C/D(Assert SCSI C\_D/ Signal)
- Bit 0 I/O(Assert SCSI I\_O/ Signal)

**Register 0Ah**  
**SCSI Selector ID (SSID)**  
*Read Only*

VAL	RES	RES	RES	ENID3	ENID2	ENID1	ENID0
7	6	5	4	3	2	1	0
Default >>>							
0	X	X	X	0	0	0	0

- Bit 7 VAL (SCSI Valid)
- Bits 6-4 Reserved
- Bits 3-0 Encoded Destination SCSI ID

**Register 0Bh**  
**SCSI Bus Control Lines (SBCL)**  
*Read Only*

REQ	ACK	BSY	SEL	ATN	MSG	C/D	I/O
7	6	5	4	3	2	1	0
Default >>>							
X	X	X	X	X	X	X	X

- Bit 7 REQ (SREQ/ Status)
- Bit 6 ACK (SACK/ Status)
- Bit 5 BSY (SBSY/ Status)
- Bit 4 SEL (SSEL/ Status)
- Bit 3 ATN (SATN/ Status)
- Bit 2 MSG (SMSG/ Status)
- Bit 1 C/D (SC\_D/ Status)
- Bit 0 I/O (SI\_O/ Status)

## Register Summary

### SCSI Registers

#### Register 0Ch DMA Status (DSTAT) Read Only

DFE	MDPE	BF	ABRT	SSI	SIR	RES	IID
7	6	5	4	3	2	1	0

Default >>>

1 0 0 0 0 0 X 0

- Bit 7 DFE (DMA FIFO Empty)
- Bit 6 MDPE (Master Data Parity Error)
- Bit 5 BF (Bus Fault)
- Bit 4 ABRT (Aborted)
- Bit 3 SSI (Single Step Interrupt)
- Bit 2 SIR (SCRIPTS Interrupt Instruction Received)
- Bit 1 Reserved
- Bit 0 IID (Illegal Instruction Detected)

#### Register 0Dh SCSI Status Zero (SSTAT0) Read Only

ILF	ORF	OLF	AIP	LOA	WOA	RST/	SDP0/
7	6	5	4	3	2	1	0

Default >>>

0 0 0 0 0 0 0 0

- Bit 7 ILF (SIDL Least Significant Byte Full)
- Bit 6 ORF (SODR Least Significant Byte Full)
- Bit 5 OLF (SODL Least Significant Byte Full)
- Bit 4 AIP (Arbitration in Progress)
- Bit 3 LOA (Lost Arbitration)
- Bit 2 WOA (Won Arbitration)
- Bit 1 RST/ (SCSI RST/ Signal)
- Bit 0 SDP0/ (SCSI SDP0/ Parity Signal)

#### Register 0Eh SCSI Status One (SSTAT1) Read Only

FF3	FF2	FF1	FF0	SDPOL	MSG	C/D	I/O
7	6	5	4	3	2	1	0

Default >>>

0 0 0 0 X X X X

- Bits 7-4 FF3-FF0 (FIFO Flags)
- Bit 3 SDPOL (Latched SCSI Parity)
- Bit 2 MSG (SCSI MSG/ Signal)
- Bit 1 C/D (SCSI C\_D/ Signal)
- Bit 0 I/O (SCSI I\_O/ Signal)

#### Register 0Fh SCSI Status Two (SSTAT2) Read Only

ILF1	ORF1	OLF1	FF4	SPL1	RES	LDSC	SDP1
7	6	5	4	3	2	1	0

Default >>>

0 0 0 0 X X 1 X

- Bit 7 ILF1 (SIDL Most Significant Byte Full)
- Bit 6 ORF1 (SODR Most Significant Byte Full)
- Bit 5 OLF1 (SODL Most Significant Byte Full)
- Bit 4 FF4 (FIFO Flags bit 4)
- Bit 3 SPL1 (Latched SCSI parity for SD15-8)
- Bit 2 Reserved
- Bit 1 LDSC (Last Disconnect)
- Bit 0 SDP1 (SCSI SDP1 Signal)

#### Registers 10h-13h Data Structure Address (DSA) Read/Write

#### Register 14h Interrupt Status (ISTAT) Read/Write

ABRT	SRST	SIGP	SEM	CON	INTF	SIP	DIP
7	6	5	4	3	2	1	0

Default >>>

0 0 0 0 0 0 0 0

- Bit 7 ABRT (Abort Operation)
- Bit 6 SRST (Software Reset)
- Bit 5 SIGP (Signal Process)
- Bit 4 SEM (Semaphore)
- Bit 3 CON (Connected)
- Bit 2 INTF (Interrupt on the Fly)
- Bit 1 SIP (SCSI Interrupt Pending)
- Bit 0 DIP (DMA Interrupt Pending)

#### Register 18h Chip Test Zero (CTEST0) Read/Write

RES	RES	RES	RES	RES	AP2	AP1	AP0
7	6	5	4	3	2	1	0

Default >>>

X X X X X 0 0 0

- Bits 7-3 Reserved
- Bits 2-0 AP2-0 (Arbitration Priority 2-0)



### Register 19h

#### Chip Test One (CTEST1)

Read Only

FMT3	FMT2	FMT1	FMT0	FFL3	FFL2	FFL1	FFL0
7	6	5	4	3	2	1	0

Default >>>

1 1 1 1 0 0 0 0

Bits 7-4 FMT3-0 (Byte Empty in DMA FIFO)

Bits 3-0 FFL3-0 (Byte Full in DMA FIFO)

### Register 1Ah

#### Chip Test Two (CTEST2)

Read Only

DDIR	SIGP	CIO	CM	SRTCH	TEOP	DREQ	DACK
7	6	5	4	3	2	1	0

Default >>>

0 0 X X 0 0 0 1

Bit 7 DDIR (Data Transfer Direction)

Bit 6 SIGP (Signal Process)

Bit 5 CIO (Configured as I/O)

Bit 4 CM (Configured as Memory)

Bit 3 SRTCH (SCRATCHA/B Operation)

Bit 2 TEOP (SCSI True End of Process)

Bit 1 DREQ (Data Request Status)

Bit 0 DACK (Data Acknowledge Status)

### Register 1Bh

#### Chip Test Three (CTEST3)

Read/Write

V3	V2	V1	V0	FLF	CLF	FM	WRIE
7	6	5	4	3	2	1	0

Default >>>

X X X X 0 0 0 0

Bits 7-4 V3-V0 (Chip Revision Level)

Bit 3 FLF (Flush DMA FIFO)

Bit 2 CLF (Clear DMA FIFO)

Bit 1 FM (Fetch Pin Mode)

Bit 0 WRIE (Write and Invalidate Enable)

### Registers 1Ch-1Fh

#### Temporary (TEMP)

Read/Write

### Register 20h

#### DMA FIFO (DFIFO)

Read/Write

B07	B06	B05	B04	B03	B02	B01	B00
7	6	5	4	3	2	1	0

Default >>>

0 0 0 0 0 0 0 0

Bits 7-0 B07-B00 (Byte offset counter)

### Register 21h

#### Chip Test Four (CTEST4)

Read/Write

BDIS	ZMOD	ZSD	SRTM	MPEE	FBL2	FBL1	FBL0
7	6	5	4	3	2	1	0

Default >>>

0 0 0 0 0 0 0 0

Bit 7 BDIS (Burst Disable)

Bit 6 ZMOD (High Impedance Mode)

Bit 5 ZSD (SCSI Data High Impedance)

Bit 4 SRTM (Shadow Register Test Mode)

Bit 3 MPEE (Master Parity Error Enable)

Bits 2-0 FBL2-FBL0 (FIFO Byte Control)

### Register 22h

#### Chip Test Five (CTEST5)

Read/Write

ADCK	BBCK	DFS	MASR	DDIR	BL2	BO9	BO8
7	6	5	4	3	2	1	0

Default >>>

0 0 0 0 0 0 0 0

Bit 7 ADCK (Clock Address Incrementor)

Bit 6 BBCK (Clock Byte Counter)

Bit 5 DFS (DMA FIFO Size)

Bit 4 MASR (Master Control for Set or Reset Pulses)

Bit 3 DDIR (DMA Direction)

Bit BL2 (Burst Length bit 2)

Bits 1-0 BO9-BO8 (DMA FIFO Byte Offset Counter, bits 9-8)

### Register 23h

#### Chip Test Six (CTEST6)

Read/Write

DF7	DF6	DF5	DF4	DF3	DF2	DF1	DF0
7	6	5	4	3	2	1	0

Default >>>

0 0 0 0 0 0 0 0

Bits 7-0 DF7-DF0 (DMA FIFO)

Register Summary  
**SCSI Registers**

**Registers 24h-26h**  
**DMA Byte Counter (DBC)**  
*Read/Write*

**Register 27h**  
**DMA Command (DCMD)**  
*Read/Write*

**Registers 28h-2Bh**  
**DMA Next Address (DNAD)**  
*Read/Write*

**Registers 2Ch-2Fh**  
**DMA SCRIPTS Pointer (DSP)**  
*Read/Write*

**Registers 30h-33h**  
**DMA SCRIPTS Pointer Save (DSPS)**  
*Read/Write*

**Registers 34h**  
**Scratch Register A (SCRATCHA)**  
*Read/Write*

**Register 38h**  
**DMA Mode (DMODE)**  
*Read/Write*

BL1	BL0	SIOM	DIOM	ER	ERMP	BOF	MAN
7	6	5	4	3	2	1	0
Default >>>							
0	0	0	0	0	0	0	0

- Bit 7-6 BL1-BL0 (Burst Length)
- Bit 5 SIOM (Source I/O-Memory Enable)
- Bit 4 DIOM (Destination I/O-Memory Enable)
- Bit 3 ERL (Enable Read Line)
- Bit 2 ERMP (Enable Read Multiple)
- Bit 1 BOF (Burst Op Code Fetch Enable)
- Bit 0 MAN (Manual Start Mode)

**Register 39h**  
**DMA Interrupt Enable (DIEN)**  
*Read/Write*

RES	MDPE	BF	ABRT	SSI	SIR	RES	IID
7	6	5	4	3	2	1	0
Default >>>							
X	0	0	0	0	0	X	0

- Bit 7 Reserved
- Bit 6 MDPE (Master Data Parity Error)
- Bit 5 BF (Bus Fault)
- Bit 4 ABRT (Aborted)
- Bit 3 SSI (Single -step Interrupt)
- Bit 2 SIR (SCRIPTS Interrupt Instruction Received)
- Bit 1 Reserved
- Bit 0 IID (Illegal Instruction Detected)

**Register 3Ah**  
**Scratch Byte Register (SBR)**  
*Read/Write*

**Register 3Bh**  
**DMA Control (DCNTL)**  
*Read/Write*

CLSE	PFF	PFEN	SSM	INTM	STD	INTD	COM
7	6	5	4	3	2	1	0
Default >>>							
0	0	0	0	0	0	0	0

- Bit 7 CLSE (Cache Line Size Enable)
- Bit 6 PFF (Pre-fetch Flush)
- Bit 5 PFEN (Pre-fetch Enable)
- Bit 4 SSM (Single-step Mode)
- Bit 3 INTM (INTA Mode)
- Bit 1 IRQD (INTA, INTB Disable)
- Bit 0 COM (53C700 Compatibility)

**Register 3Ch-3Fh**  
**Adder Sum Output (ADDER)**  
*Read Only*

**Register 40h**

**SCSI Interrupt Enable Zero (SIEN0)**

*Read/Write*

M/A	CMP	SEL	RSL	SGE	UDC	RST	PAR
7	6	5	4	3	2	1	0

Default >>>

0	0	0	0	0	0	0	0
---	---	---	---	---	---	---	---

Bit 7 M/A (SCSI Phase Mismatch - Initiator Mode; SCSI ATN Condition - Target Mode)

Bit 6 CMP (Function Complete)

Bit 5 SEL (Selected)

Bit 4 RSL (Reselected)

Bit 3 SGE (SCSI Gross Error)

Bit 2 UDC (Unexpected Disconnect)

Bit 1 RST (SCSI Reset Condition)

Bit 0 PAR (SCSI Parity Error)

**Register 41h**

**SCSI Interrupt Enable One (SIEN1)**

*Read/Write*

RES	RES	RES	RES	RES	STO	GEN	HTH
7	6	5	4	3	2	1	0

Default >>>

X	X	X	X	X	0	0	0
---	---	---	---	---	---	---	---

Bits 7-3 Reserved

Bit 2 STO (Selection or Reselection Time-out)

Bit 1 GEN (General Purpose Timer Expired)

Bit 0 HTH (Handshake-to-Handshake Timer Expired)

**Register 42h**

**SCSI Interrupt Status Zero (SIST0)**

*Read Only*

M/A	CMP	SEL	RSL	SGE	UDC	RST	PAR
7	6	5	4	3	2	1	0

Default >>>

0	0	0	0	0	0	0	0
---	---	---	---	---	---	---	---

Bit 7 M/A (Initiator Mode: Phase Mismatch; Target Mode: SATN/ Active)

Bit 6 CMP (Function Complete)

Bit 5 SEL (Selected)

Bit 4 RSL (Reselected)

Bit 3 SGE (SCSI Gross Error)

Bit 2 UDC (Unexpected Disconnect)

Bit 1 RST (SCSI RST/ Received)

Bit 0 PAR (Parity Error)

**Register 43h**

**SCSI Interrupt Status One (SIST1)**

*Read Only*

RES	RES	RES	RES	RES	STO	GEN	HTH
7	6	5	4	3	2	1	0

Default >>>

X	X	X	X	0	0	0	0
---	---	---	---	---	---	---	---

Bits 7-4 Reserved

Bit 2 STO (Selection or Reselection Time-out)

Bit 1 GEN (General Purpose Timer Expired)

Bit 0 HTH (Handshake-to-Handshake Timer Expired)

**Register 44h**

**SCSI Longitudinal Parity (SLPAR)**

*Read/Write*

**Register 45h**

**SCSI Wide Residue (SWIDE)**

*Read/Write*

**Register 46h**

**Memory Access Control (MACNTL)**

*Read/Write*

TYP3	TYP2	TYP1	TYP0	RES	RES	RES	RES
7	6	5	4	3	2	1	0

Default >>>

0	1	1	1	X	X	X	X
---	---	---	---	---	---	---	---

Bits 7-4 TYP3-0 (Chip Type)

Bit 3-0 Reserved

**Register 47h**

**General Purpose Pin Control (GPCNTL)**

*Read/Write*

ME	FE	RES	GPIO4	GPIO3	GPIO2	GPIO1	GPIO0
7	6	5	4	3	2	1	0

Default >>>

0	0	X	0	1	1	1	1
---	---	---	---	---	---	---	---

Bit 7 Master Enable

Bit 6 Fetch Enable

Bits 5 Reserved

Bits 4, 2 GPIO4\_EN-GPIO2\_EN (GPIO Enable)

Bits 1-0 GPIO1\_EN-GPIO0\_EN (GPIO Enable)

Register Summary  
SCSI Registers

**Register 48h**  
SCSI Timer Zero (STIME0)  
Read/Write

HTH7	HTH6	HTH5	HRH4	SEL	SEL	SEL	SEL
7	6	5	4	3	2	1	0

Default >>>  
0 0 0 0 0 0 0 0

Bits 7-4 HTH (Handshake-to-Handshake Timer Period)  
Bits 3-0 SEL (Selection Time-Out)

**Register 49h**  
SCSI Timer One (STIME1)  
Read/Write

RES	HTHBA	GENSF	HTHSF	GEN3	GEN2	GEN1	GEN0
7	6	5	4	3	2	1	0

Default >>>  
X 0 0 0 0 0 0 0

Bit 7 Reserved  
Bit 6 HTHBA (Handshake-to-Handshake Timer Bus Activity Enable)  
Bit 5 GENSF (General Purpose Timer Scale Factor)  
Bit 4 HTHSF (Handshake to Handshake Timer Scale Factor)  
Bits 3-0 GEN3-0 (General Purpose Timer Period)

**Register 4Ah**  
Response ID Zero (RESPID0)  
Read/Write

ID	ID	ID	ID	ID	ID	ID	ID
7	6	5	4	3	2	1	0

Default >>>  
X X X X X X X X

**Register 4Bh**  
Response ID One (RESPID1)  
Read/Write

ID	ID	ID	ID	ID	ID	ID	ID
15	14	13	12	11	10	9	8

Default >>>  
X X X X X X X X

**Register 4Ch**  
SCSI Test Zero (STEST0)  
Read Only

SSAID3	SSAID2	SSAID1	SSAID0	SLT	ART	SOZ	SOM
7	6	5	4	3	2	1	0

Default >>>  
0 0 0 0 0 X 1 1

Bits 7-4 SSAID3-0 (SCSI Selected As ID)  
Bit 3 SLT (Selection Response Logic Test)  
Bit 2 ART (Arbitration Priority Encoder Test)  
Bit 1 SOZ (SCSI Synchronous Offset Zero)  
Bit 0 SOM (SCSI Synchronous Offset Maximum)

**Register 4Dh**  
SCSI Test One (STEST1)  
Read/Write

SCLK	ISO	RES	RES	DBLEN	DBLSEL	RES	RES
7	6	5	4	3	2	1	0

Default >>>  
0 0 X X 0 0 X X

Bit 7 SCLK  
Bit 6 ISO\_MODE (SCSI Isolation Mode)  
Bit 5 Reserved  
Bit 4 Reserved  
Bit 3 DBLEN (SCLK Doubler Enable)  
Bit 2 DBLSEL (SCLK Doubler Select)  
Bits 1-0 Reserved

**Register 4Eh**  
SCSI Test Two (STEST2)  
Read/Write

SCE	ROF	DIF	SLB	SZM	AWS	EXT	LOW
7	6	5	4	3	2	1	0

Default >>>  
0 0 0 0 0 0 0 0

Bit 7 SCE (SCSI Control Enable)  
Bit 6 ROF (Reset SCSI Offset)  
Bit 5 DIF  
Bit 4 SLB (SCSI Loopback Mode)  
Bit 3 SZM (SCSI High-Impedance Mode)  
Bit 2 AWS (Always Wide SCSI)  
Bit 1 EXT (Extend SREQ/SACK Filtering)  
Bit 0 LOW (SCSI Low level Mode)

**Register 4Fh**  
**SCSI Test Three (STEST3)**  
*Read/Write*

TE	STR	HSC	DSI	DIFF	TTM	CSF	STW
7	6	5	4	3	2	1	0
Default >>>							
0	0	0	0	X	0	0	0

- Bit 7      TE (TolerANT Enable)
- Bit 6      STR (SCSI FIFO Test Read)
- Bit 5      HSC (Halt SCSI Clock)
- Bit 4      DSI (Disable Single Initiator Response)
- Bit 3      DIFF DIFFSENSE Sense
- Bit 2      TTM (Timer Test Mode)
- Bit 1      CSF (Clear SCSI FIFO)
- Bit 0      STW (SCSI FIFO Test Write)

**Register 50h-51h**  
**SCSI Input Data Latch (SIDL)**  
*Read Only*

**Registers 54h-55h**  
**SCSI Output Data Latch (SODL)**  
*Read/Write*

**Registers 58h-59h**  
**SCSI Bus Data Lines (SBDL)**  
*Read Only*

**Registers 5Ch-5Fh**  
**Scratch Register B (SCRATCHB)**  
*Read/Write*

**Registers 60h-7Fh**  
**Scratch Registers C-J**  
**(SCRATCHC-SCRATCHJ)**  
*Read/Write*



## Appendix B

# Mechanical Drawings

Symbios Logic component dimensions conform to a current revision of the JEDEC Publication 95 standard package outline, using ANSI 14.5Y “Dimensioning and Tolerancing” interpretations. As JEDEC drawings are balloted and updated, changes may have occurred. To ensure the use of a current drawing, the JEDEC drawing revision level should be verified. Visit [www.eia.org/jedec](http://www.eia.org/jedec) for review of Publication 95 drawings and revision levels.

For printed circuit board land patterns that will accept Symbios Logic components, it is recommended that customers refer to the IPC standards (Institute for Interconnecting and Packaging Electronic Circuits). Specification number IPC-SM-782, “Surface Mount Design and Land Pattern Standard” is an established method of designing land patterns. Feature size and tolerances are industry standards based on IPC assumptions.

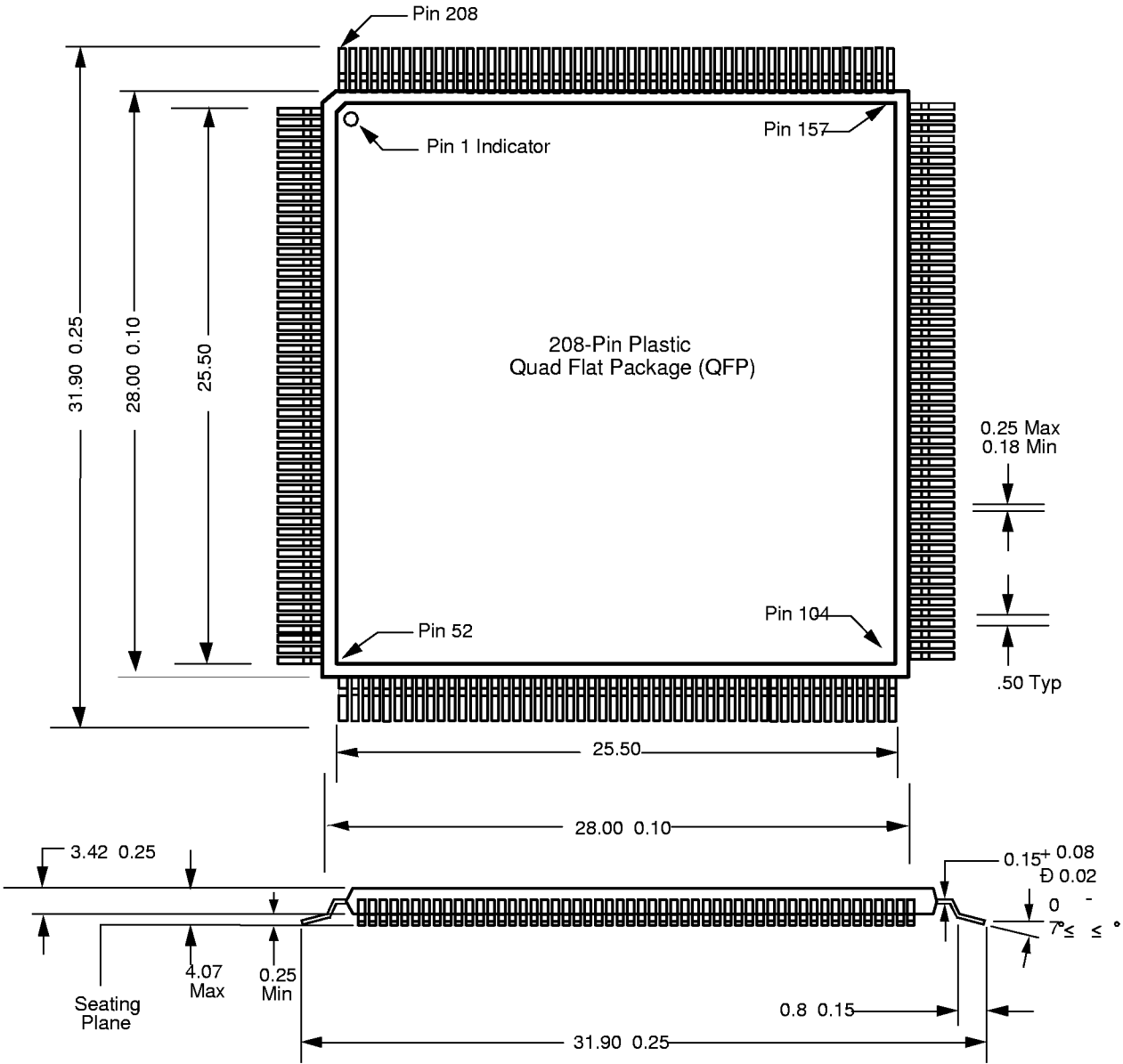

Figure B-1:SYM53C876 208-Pin PQFP Mechanical Drawing



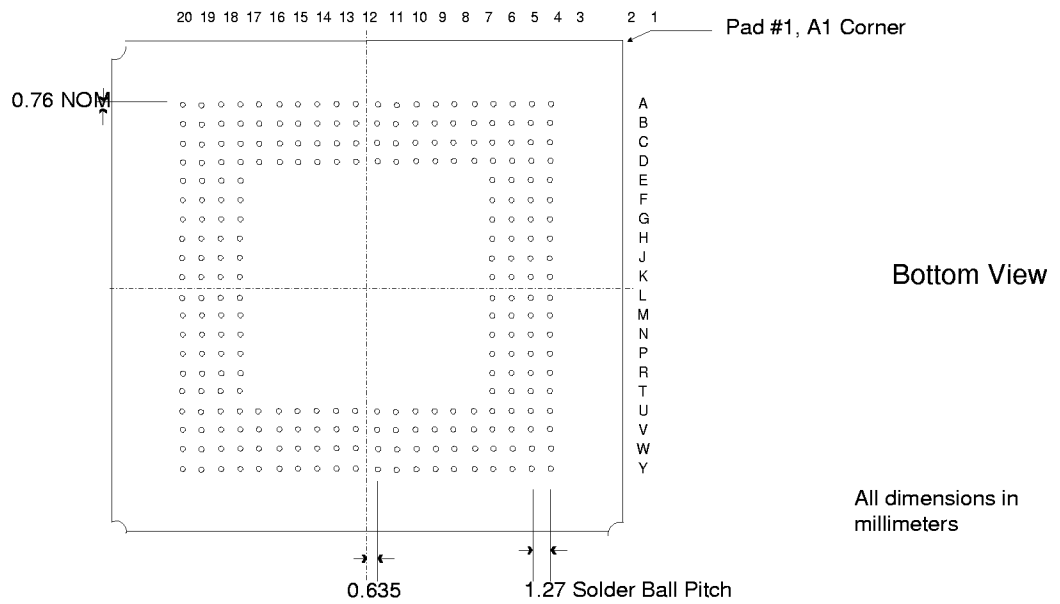
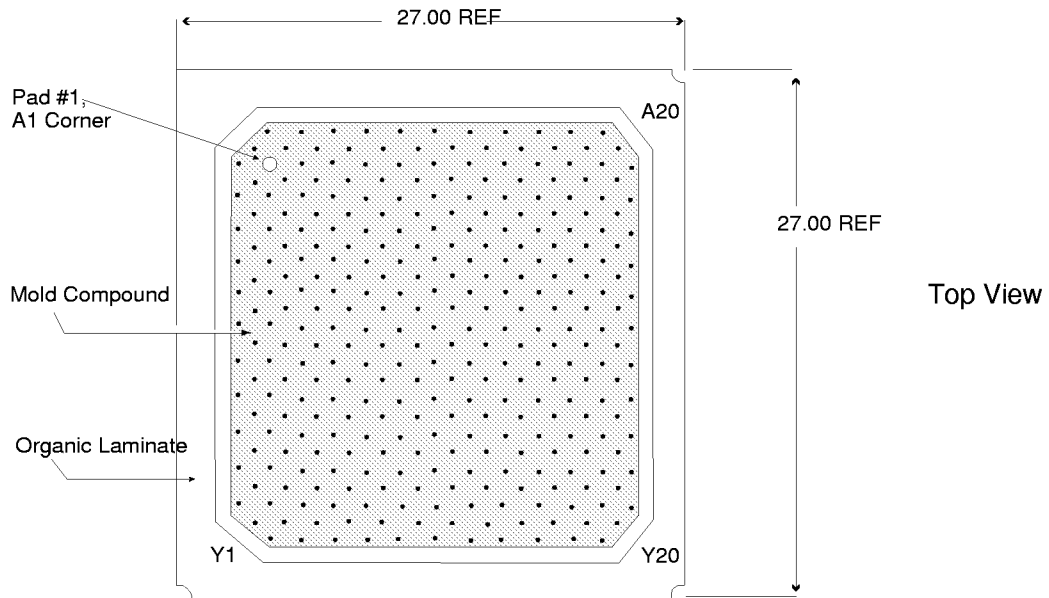
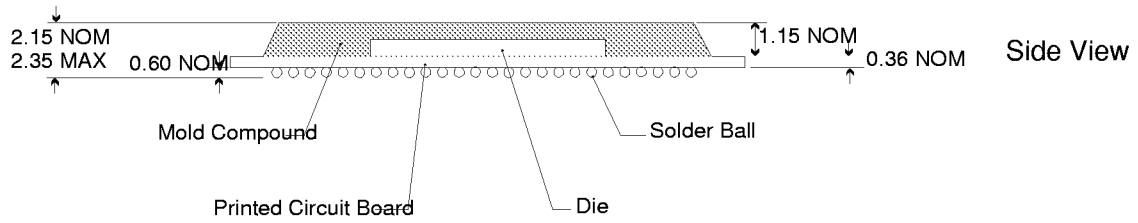
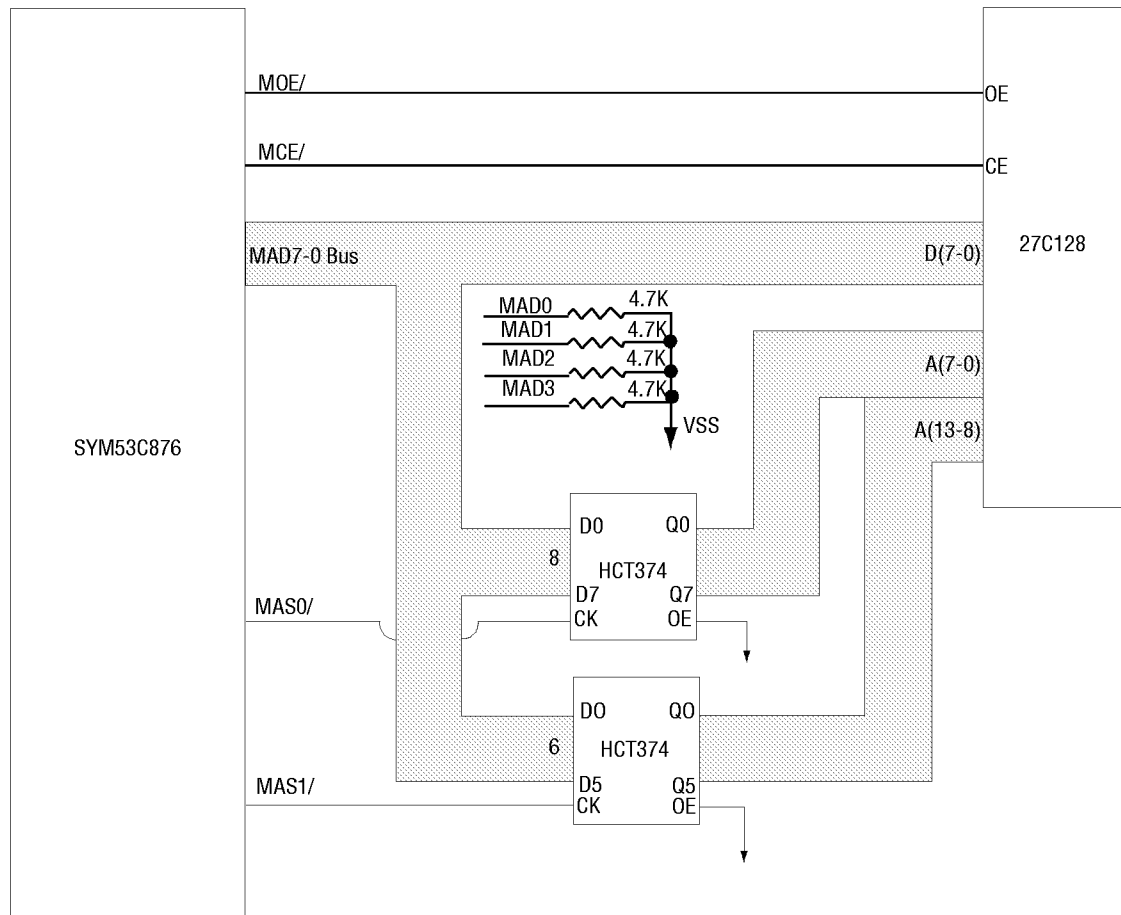

Figure B-2:SYM53C876 256-Bump PBGA Mechanical

Drawing

**Mechanical Drawings**

# Appendix C External Memory Interface Diagram Examples



MAD3-1 pulled low internally.  
MAD Bus Sense Logic Enabled for 16 KB of slow memory (200 ns Device @ 33MHz)

**Figure C-1:16 K Interface With 200 ns Memory**

# External Memory Interface Diagram Examples

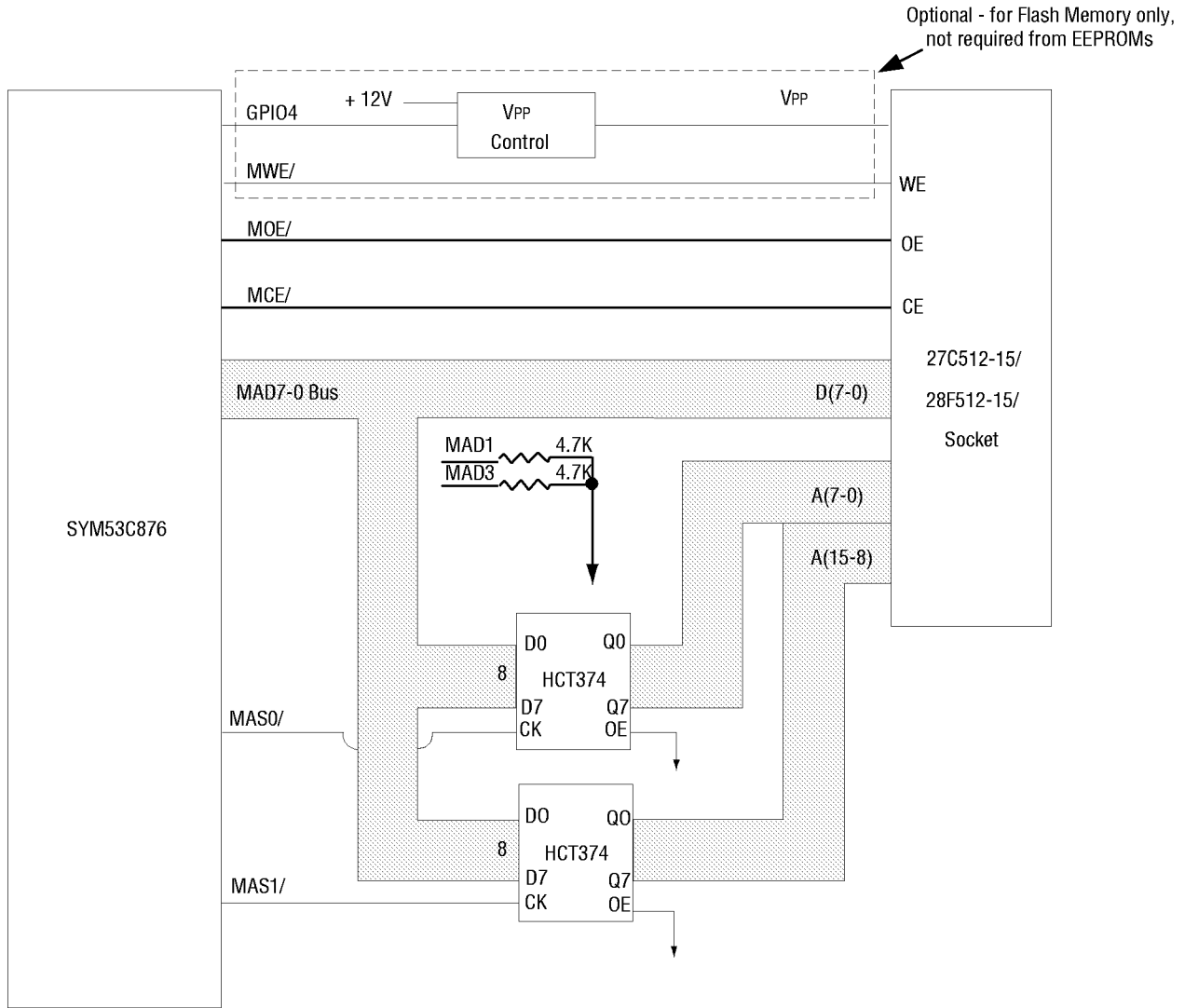

MAD3, 1, 0 pulled low internally.  
 MAD Bus Sense Logic Enabled for 64 KB of fast memory (150 ns Device @ 33MHz)

**Figure C-2:64 K Interface with 150 ns Memory**

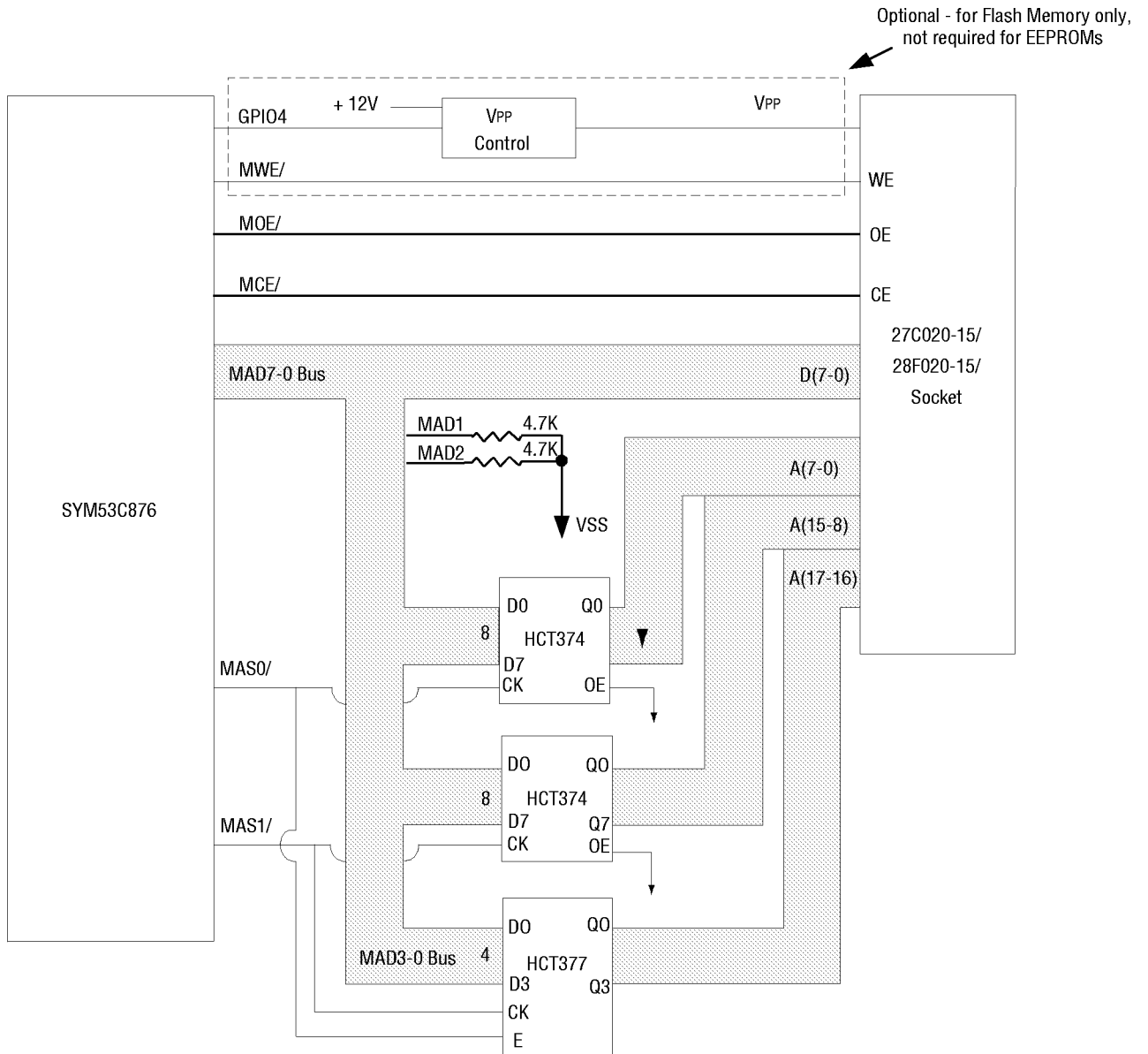

MAD2, 1, 0 pulled low internally.  
 MAD Bus Sense Logic Enabled for 256 KB of fast memory (150 ns Device @ 33MHz).  
 The HCT374s may be replaced with HCT377s.

**Figure C-3:256 K Interface With 150 ns Memory**

## External Memory Interface Diagram Examples

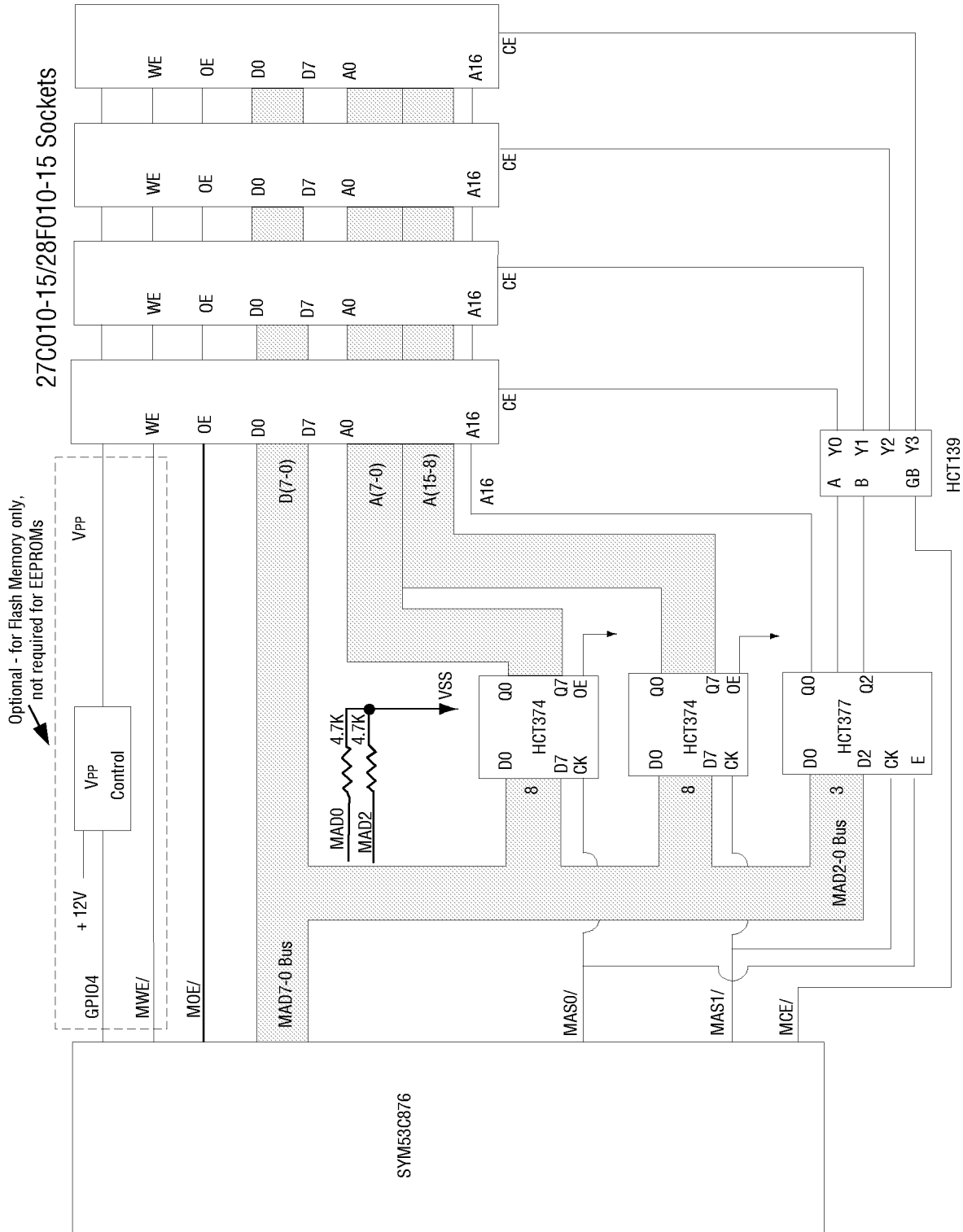

Figure C-4:512 K Interface With 150 ns Memory

MAD Bus Sense Logic Enabled for 512 KB of slow memory (150 ns Devices, additional 1 time required for HCT139 @ 33MHz).  
 The HCT1374s may be replaced with HCT1377s.  
 MAD2 pulled low internally.

## External Memory Interface Diagram Examples



---

# Index

## Numerics

3.3/5 Volt PCI interface, 2-7, 2-10  
 40 MHz clock doubler, 2-20  
 53C700 Compatibility bit, 4-51, A-7

## A

Abort Operation bit, 4-36, A-5  
 Aborted bit, 4-32, 4-49, A-5, A-7  
 Absolute Maximum Stress Ratings, 6-1  
 AC Characteristics, 6-13  
     PCI and External Memory Interface Timings, 6-16  
     SCSI Interface Timings, 6-54  
 active negation  
     see TolerANT Technology  
 active termination, 2-19  
 AD(31-0), 3-6  
 ADDER register, 4-53, A-7  
 Adder Sum Output register, 4-53, A-7  
 Address/Data bus, 2-3  
 Address/Data Pins, 3-6  
 Alignment, 2-7  
 Alternative Two Termination, 2-19  
 Always Wide SCSI bit, 4-65, A-9  
 Arbitration in Progress bit, 4-33, A-5  
 arbitration  
     Arbitration in Progress bit, 4-33, A-5  
     Arbitration Mode bits, 4-20, A-3  
     Full Arbitration, 4-20  
     Immediate Arbitration bit, 4-23, A-3  
     Lost Arbitration bit, 4-33, A-5  
     Simple Arbitration, 4-20  
     Won Arbitration bit, 4-33, A-5  
 Arbitration Mode bits, 4-20, A-3  
 Arbitration Pins, 3-8  
 Arbitration Priority Encoder Test bit, 4-63, A-9  
 ASPI, 1-3  
 Assert Even SCSI Parity bit, 4-22, A-3

Assert SATN/ on Parity Error bit, 4-21, A-3  
 Assert SCSI ACK/ Signal bit, 4-30, A-4  
 Assert SCSI ATN/ Signal bit, 4-30, A-4  
 Assert SCSI BSY/ Signal bit, 4-30, A-4  
 Assert SCSI C\_D/ Signal bit, 4-30, A-4  
 Assert SCSI Data Bus bit, 4-22, A-3  
 Assert SCSI I\_O Signal bit, 4-30, A-4  
 Assert SCSI MSG/ Signal bit, 4-30, A-4  
 Assert SCSI REQ/ Signal bit, 4-30, A-4  
 Assert SCSI RST/ Signal bit, 4-22, A-3  
 Assert SCSI SEL/ Signal bit, 4-30, A-4  
 Asynchronous SCSI Receive, 2-15  
 Asynchronous SCSI Send, 2-14  
 Auto-Configuration Disable, 3-18

## B

Base Address Register One, 2-3  
 bi-directional, 3-4  
 Big and Little Endian Support, 2-10  
 BIOS, 2-3  
 BIOS ROM, 1-1  
 Bits Used for Parity Control and Generation, 2-12  
 Block Move and Chained Block Move Instructions, 2-27  
 Block Move Instructions, 5-3  
 BSYDIR, 3-13  
 Burst Disable bit, 4-42, A-6  
 Burst Length bits, 4-44, 4-48, A-6, A-7  
 Burst Op Code Fetch Enable bit, 4-48, A-7  
 Burst Size Selection, 2-5  
 Bus command and byte enables, 3-6  
 Bus Fault bit, 4-31, 4-49, A-5, A-7  
 Byte Empty in DMA FIFO bit, 4-39, A-6  
 Byte Full in DMA FIFO bit, 4-39, A-6  
 Byte Offset Counter bits, 4-42, 4-44, A-6

**C**

- C\_BE/ (3-0), 2-3, 3-6
- Cache Line Size Enable bit, 4-51, A-7
- Cache Line Size Register, 2-5
- cache mode, see PCI cache mode, 2-7
- CCF2 – 0, 2-20
- Chained Block Move SCRIPTS Instruction, 2-26
- chained block moves, 2-25–2-27
  - SODL register, 2-26
  - SWIDE register, 2-26
  - Wide SCSI Receive Bit, 2-25
  - Wide SCSI Send Bit, 2-25
- Chained Mode bit, 4-24, A-3
- Chip Revision Level bits, 4-40, A-6
- Chip Test Five register, 4-43, A-6
- Chip Test Four register, 4-42, A-6
- Chip Test One register, 4-39, A-6
- Chip Test Six register, 4-44, A-6
- Chip Test Two register, 4-39, A-6
- Chip Test Zero register, 4-38, A-5
- Chip Type bits, 4-59, A-8
- CHMOV, 2-25
- Clear DMA FIFO, 2-24
- Clear DMA FIFO bit, 4-40, A-6
- Clear SCSI FIFO bit, 4-66, A-10
- CLF, 2-24
- CLK, 3-5
- Clock, 3-5
- Clock Address Incrementor bit, 4-43, A-6
- Clock Byte Counter bit, 4-43, A-6
- Clock Conversion Factor, 2-20
- Clock Conversion Factor bits, 4-26, A-3
- CLSE, 2-5
- CMP, 2-23
- Configuration Read Command, 2-4
- Configuration Registers, 4-1
  - Base Address One (Memory), 4-8
  - Base Address Two (Memory), 4-9
  - Base Address Zero (I/O), 4-8
  - BIST, 4-7
  - Cache Line Size, 4-6
  - Capabilities Pointer, 4-11
  - Capability ID, 4-13
  - Class Code, 4-5
  - Command, 4-3
  - Data, 4-16
  - Device ID, 4-2
  - Expansion ROM Base Address, 4-10
  - Header Type, 4-7
  - Interrupt Line, 4-11
  - Interrupt Pin, 4-12
  - Latency Timer, 4-6
  - Max\_Lat, 4-13
  - Min\_Gnt, 4-12
  - Next Item Pointer, 4-14
  - Power Management Capabilities, 4-14
  - Power Management Control/Status, 4-14, 4-15
  - Revision ID, 4-5
  - Status, 4-4
  - Subsystem ID, 4-10
  - Subsystem Vendor ID, 4-9
  - Vendor ID, 4-2
- Configuration Space, 2-3
- Configuration space, 2-2
- Configuration Write Command, 2-5
- Configured as I/O bit, 4-39, A-6
- Configured as Memory bit, 4-39, A-6
- Connected bit, 4-22, 4-37, A-3, A-5
- Conventions, 1-6
- CSF, 2-24
- CTEST0 register, 4-38, A-5
- CTEST1 register, 4-39, A-6
- CTEST2 register, 4-39, A-6
- CTEST4 register, 4-42, A-6
- CTEST5 register, 4-43, A-6
- CTEST6 register, 4-44, A-6
- Cycle Frame, 3-7

**D**

- Data Acknowledge Status bit, 4-40, A-6
- data path, 2-14
- Data Paths, 2-14
- Data Request Status bit, 4-40, A-6
- Data Structure Address register, 4-36, A-5
- Data Transfer Direction bit, 4-39, A-6
- Data-In, 2-26

- Data-Out, 2-26
  - DBC register, 4-45, A-7
  - DCMD register, 4-45, A-7
  - DCNTL, 2-5, 2-23
  - DCNTL register, 4-51, A-7
  - Decode of MAD pins, 3-18
  - Designing a Fast-20 SCSI System, 2-21
  - Destination I/O-Memory Enable bit, 4-48, A-7
  - Determining the Data Transfer Rate, 2-20
  - Determining the Synchronous Transfer Rate, 2-21
  - Device Select, 3-7
  - DEVSEL/, 3-7
  - DFIFO register, 4-42, A-6
  - DIEN, 2-22, 2-23
  - DIEN register, 4-49, A-7
  - differential mode
    - operation, 2-16
  - DIFFSENS, 3-13, 3-14
  - DIFFSENSE Sense, A-10
  - DIP, 2-22, 2-24
  - DIP bit, 2-25
  - Disable Halt on Parity Error or ATN, 4-22, A-3
  - Disable Single Initiator Response bit, 4-66, A-10
  - DMA Byte Counter register, 4-45, A-7
  - DMA Command register, 4-45, A-7
  - DMA Control register, 4-51, A-7
  - DMA core, 1-3
  - DMA Direction bit, 4-44, A-6
  - DMA FIFO, 2-6, 2-14, 2-22
  - DMA FIFO bits, 4-44, A-6
  - DMA FIFO Empty bit, 4-31, A-5
  - DMA FIFO register, 4-42, A-6
  - DMA FIFO Sections, 2-14
  - DMA Interrupt Enable register, 4-49, A-7
  - DMA Interrupt Pending bit, 4-38, A-5
  - DMA interrupts, 2-23, 2-24
  - DMA Mode register, 4-48, A-7
  - DMA Next Address register, 4-46, A-7
  - DMA SCRIPTS Pointer register, 4-46, A-7
  - DMA SCRIPTS Pointer Save register, 4-47, A-7
  - DMA Status register, 4-31, A-5
  - DMODE, 2-5
  - DMODE Register, 2-10
  - DMODE register, 4-48, A-7
  - DNAD register, 4-46, A-7
  - DSA register, 4-36, A-5
  - DSP register, 4-46, A-7
  - DSPS register, 4-47, A-7
  - DSTAT, 2-22, 2-24, 2-25
  - DSTAT register, 4-31, A-5
  - Dual Address Cycles Command, 2-5
- E**
- Electrical Characteristics, 6-1
    - AC Characteristics, 6-13
    - DC Characteristics, 6-1
      - 3.3 Volt PCI, 6-7
    - TolerANT Technology, 6-9
  - Enable Parity Checking, 2-11
  - Enable Parity Checking bit, 4-21, A-3
  - Enable Read Line bit, 4-48, A-7
  - Enable Read Multiple bit, 4-48, A-7
  - Enable Response to Reselection bit, 4-26, A-4
  - Enable Response to Selection bit, 4-26, A-4
  - Enable Wide SCSI bit, 4-26, A-3
  - Encoded Chip SCSI ID, 4-26, A-4
  - Encoded Destination SCSI ID bit, 4-30, A-4
  - Encoded Destination SCSI ID bits, 4-28, A-4
  - EPROMs, 1-1
  - Error Recording Pins, 3-8
  - Even Parity, 2-11
  - Expanded Register Move, 1-5
  - Expansion ROM Base Address Register, 2-28
  - Extend SREQ/SACK Filtering bit, 4-65, A-9
  - External Memory Configurations, 6-16
  - external memory interface, 2-28
    - configuration, 2-28
    - GPIO4 bit, 4-29, A-4
    - slow memory, 2-28
  - Extra Clock Cycle of Data Setup bit, 4-22, A-3
- F**
- Fetch Enable, 4-60, A-8
  - Fetch Pin Mode bit, 4-41, A-6
  - FIFO Byte Control bits, 4-43, A-6
  - FIFO Flags bits, 4-34, 4-35, A-5
  - Flush DMA FIFO bit, 4-40, A-6

## Index

FRAME/, 3-7

Function Complete, 2-23

Function Complete bit, 4-53, 4-55, A-8

## G

General Purpose I/O pin 0, 3-10

General purpose I/O pin 1, 3-10

General Purpose I/O pin 2, 3-10

General purpose I/O pin 3, 3-10

General purpose I/O pin 4, 3-10

General Purpose Pin Control register, 4-60, A-8

General Purpose register, 4-29, A-4

General Purpose Timer Expired bit, 4-55, 4-57, A-8

General Purpose Timer Period bits, 4-61, A-9

General Purpose Timer Scale Factor bit, 4-61, A-9

GNT/, 3-8

GPCNTL register, 4-60, A-8

GPI00\_FETCH/, 3-10

GPIO Enable bit, 4-60, A-8

GPIO Interface Pins, 3-10

GPIO1\_MASTER/, 3-10

GPIO2, 3-10

GPIO3, 3-10

GPIO4, 3-10

GPIO4-0 bits, 4-29, A-4

GPREG register, 4-29, A-4

Grant, 3-8

## H

Halt SCSI Clock bit, 4-66, A-10

Handshake-to-Handshake Timer Bus Activity Enable bit, 4-61, A-9

Handshake-to-Handshake Timer Expired bit, 4-55, 4-57, A-8

Handshake-to-Handshake Timer Period bit, 4-60, A-9

Hardware Interrupts, 2-22

High Impedance Mode bit, 4-42, A-6

## I

I/O Instructions, 5-7

I/O Read Command, 2-4

I/O Space, 2-3

I/O space, 2-2

I/O Write Command, 2-4

IDSEL, 2-3, 3-7

IDSEL signal, 2-4

IGS, 3-13, 3-14

Illegal Instruction Detected bit, 4-32, A-5

Immediate Arbitration bit, 4-23, A-3

Initialization Device Select, 3-7

Initiator Ready, 3-7

Input, 3-4

instruction prefetching, 2-9

Pre-fetch Enable bit, 4-51, A-7

Pre-fetch Flush bit, 4-51, A-7

prefetch unit flushing, 2-9

instructions

block move, 5-3

I/O, 5-7

load and store, 5-22

memory move, 5-20

read/write, 5-12

transfer control, 5-15

INTA routing enable, 3-18

INTA/, 2-22, 3-9, 3-18

INTA/ pin, 2-23, 2-25

INTB/, 3-9, 3-18

Integration, 1-5

Interface Control Pins, 3-7

Internal Arbiter, 2-7

internal RAM, see also SCRIPTS RAM, 2-9

Internal SCRIPTS RAM, 2-9

Interrupt A, 3-9

Interrupt B, 3-9

Interrupt on the Fly bit, 4-37, A-5

Interrupt Request, 2-22

Interrupt Status register, 4-36, A-5

Interrupts, 2-23

interrupts, 2-21

fatal vs. non-fatal interrupts, 2-23

halting, 2-24

IRQ Disable bit, 2-23

masking, 2-23

sample interrupt service routine, 2-24

- stacked interrupts, 2-24
- IRDY/, 3-7
- IRQ Disable bit, 4-51, A-7
- ISTAT, 2-22, 2-25
- ISTAT register, 4-36, A-5

**J**

- JTAG Boundary Scan Testing, 2-10

**L**

- Last Disconnect bit, 4-35, A-5
- Latched SCSI Parity bit, 4-34, A-5
- Latched SCSI Parity for SD15-8 bit, 4-35, A-5
- Latency, 2-7
- load and store instructions, 5-22
  - no flush option, 5-23
  - prefetch unit and Store instructions, 2-10, 5-23
- Load and Store SCRIPTS, 1-5
- Load/Store Instructions, 2-10
- Lost Arbitration bit, 4-33, A-5

**M**

- MACNTL register, 4-59, A-8
- MAD bus, 2-28
- MAD Bus Programming, 3-18
- MAD pins, 2-28
- MAD(7-0) pins, 3-18
- MAD7-0, 3-15
- Manual Start Mode bit, 4-49, A-7
- MAS0/, 3-15
- MAS1/, 3-15
- Masking, 2-23
- Master Control for Set or Reset Pulses bit, 4-43, A-6
- Master Data Parity Error bit, 4-31, 4-49, A-5, A-7
- Master Enable bit, 4-60, A-8
- Master Parity Error Enable bit, 4-43, A-6
- Max SCSI Synchronous Offset bits, 4-28, A-4
- MCE/, 3-16
- Memory Access Control register, 4-59, A-8
- Memory Address Strobe 0, 3-15
- Memory Address Strobe 1, 3-15
- Memory Address/Data Bus, 3-15
- Memory Chip Enable, 3-16

- Memory Move instruction, 2-8
- Memory Move instructions, 5-20
  - and SCRIPTS instruction prefetching, 2-9
  - No Flush option, 2-9
- Memory Move Misalignment, 2-8
- Memory Output Enable, 3-16
- Memory Read Command, 2-4
- Memory Read Line Command, 2-5
- Memory Read Multiple Command, 2-5
- Memory Space, 2-3
- Memory space, 2-2
- Memory Write and Invalidate Command, 2-6
- Memory Write Command, 2-4
- Memory Write Enable, 3-15
- MOE\_TESTOUT, 3-16
- Multiple Cache Line Transfers, 2-6
- multi-threaded I/O, 1-5
- MWE/, 3-15

**N**

- No Flush Memory Move instruction, 5-21

**O**

- Objectives of DMA architecture, 2-28
- Op Code Fetch Burst Capability, 2-10
- op code fetch bursting, 2-10
- Operating Conditions, 6-1
- operating registers
  - Adder Sum Output, 4-53, A-7
  - Chip Test Five, 4-43, A-6
  - Chip Test Four, 4-42, A-6
  - Chip Test One, 4-39, A-6
  - Chip Test Six, 4-44, A-6
  - Chip Test Three, 4-40, A-6
  - Chip Test Two, 4-39, A-6
  - Chip Test Zero, 4-38, A-5
  - Data Structure Address, 4-36, A-5
  - DMA Byte Counter, 4-45, A-7
  - DMA Command, 4-45, A-7
  - DMA Control, 4-51, A-7
  - DMA FIFO, 4-42, A-6
  - DMA Interrupt Enable, 4-49, A-7
  - DMA Mode, 4-48, A-7
  - DMA Next Address, 4-46, A-7

DMA SCRIPTS Pointer, 4-46, A-7  
 DMA SCRIPTS Pointer Save, 4-47, A-7  
 DMA Status, 4-31, A-5  
 General Purpose, 4-29, A-4  
 General Purpose Pin Control, 4-60, A-8  
 Interrupt Status, 4-36, A-5  
 Memory Access Control, 4-59, A-8  
   register address map, 4-18  
 Response ID One, 4-62, A-9  
 Response ID Zero, 4-62, A-9  
 Scratch Register A, 4-47, A-7  
 Scratch Register B, 4-69, A-10  
 SCSI Bus Control Lines, 4-31, A-4  
 SCSI Bus Data Lines, 4-69, A-10  
 SCSI Chip ID, 4-26, A-4  
 SCSI Control One register, 4-22, A-3  
 SCSI Control Register Two, 4-24, A-3  
 SCSI Control Three, 4-25, A-3  
 SCSI Control Zero, 4-20, A-3  
 SCSI Destination ID, 4-28, A-4  
 SCSI First Byte Received, 4-29, A-4  
 SCSI Input Data Latch, 4-68, A-10  
 SCSI Interrupt Enable One, 4-55, A-8  
 SCSI Interrupt Enable Zero, 4-53, A-8  
 SCSI Interrupt Status One, 4-57, A-8  
 SCSI Interrupt Status Zero, 4-55, A-8  
 SCSI Longitudinal Parity, 4-58, A-8  
 SCSI Output Control Latch, 4-30, A-4  
 SCSI Output Data Latch, 4-68, A-10  
 SCSI Selector ID, 4-30, A-4  
 SCSI Status One, 4-34, A-5  
 SCSI Status Two, 4-35, A-5  
 SCSI Status Zero, 4-33, A-5  
 SCSI Test One, 4-64, A-9  
 SCSI Test Three, 4-66, A-10  
 SCSI Test Two, 4-65, A-9  
 SCSI Test Zero, 4-63, A-9  
 SCSI Timer One, 4-61, A-9  
 SCSI Timer Zero, 4-60, A-9  
 SCSI Transfer, 4-27, A-4  
 SCSI Wide Residue, 4-59, A-8  
 Temporary Stack, 4-41, A-6

## P

PAR, 3-6  
 Parallel ROM Interface, 2-28  
 Parallel ROM Support, 2-28  
 Parity, 2-11–2-13, 3-6  
 Parity Error, 3-8  
 Parity Error bit, 4-56, A-8  
 PCI Addressing, 2-2  
 PCI and External Memory Interface Timings, 6-16  
   Symbols and Parameters, 6-53  
 PCI Bus Commands and Encoding Types, 2-4  
 PCI Bus Commands and Functions Supported, 2-3  
 PCI Cache Line Size Register, 2-6  
 PCI cache mode, 2-7  
   Cache Line Size Enable bit, 4-51, A-7  
   Enable Read Multiple bit, 4-48, A-7  
   Write and Invalidate Enable bit, 4-41, A-6  
 PCI commands, 2-3  
 PCI configuration registers, 4-1–4-16  
 PCI Functional Description, 2-2  
 PCI I/O space, 2-3  
 PCI Interface Pins, 3-5, 3-7  
 PCI Interrupt Pins, 3-9  
 PCI memory space, 2-3  
 PCI Performance, 1-5  
 PCI Target Disconnect, 2-7  
 PCI Target Retry, 2-7  
 PERR/, 3-8  
 Phase Mismatch bit, 4-55, A-8  
 Physical longword address and data, 3-6  
 Pin Diagram, 3-1  
 Polling, 2-22  
 Power Management, 2-32  
   Isolated Power Supplies, 2-32  
   Power State D0, 2-32  
   Power State D1, 2-32  
   Power State D2, 2-32  
   Power State D3, 2-32  
   Register 40h, Capability ID, 4-13  
   Register 41h, Next Item Pointer, 4-14

- Register 42h, Power Management Capabilities, 4-14
  - Register 44h, Control/Status, 4-15
  - Register 46h, PMCSR BSE, 4-15
  - Register 47h, Data, 4-16
  - Pre-fetch Enable bit, 4-51, A-7
  - Pre-fetch Flush bit, 4-51, A-7
- R**
- RAM, see also SCRIPTS RAM, 2-9
  - Read Line Mode, 2-5
  - Read Multiple with Read Line Enabled, 2-6
  - Read/Write Instructions, 5-12
  - register addresses
    - operating registers
      - 01h, 4-22, A-3
      - 02h, 4-24, A-3
      - 03h, 4-25, A-3
      - 04h, 4-26, A-4
      - 05h, 4-27, A-4
      - 06h, 4-28, A-4
      - 07h, 4-29, A-4
      - 08h, 4-29, A-4
      - 09h, 4-30, A-4
      - 0Ah, 4-30, A-4
      - 0Bh, 4-31, A-4
      - 0Ch, 4-31, A-5
      - 0Dh, 4-33, A-5
      - 0Eh, 4-34, A-5
      - 0Fh, 4-35, A-5
      - 10-13h, 4-36, A-5
      - 14h, 4-36, A-5
      - 18h, 4-38, A-5
      - 19h, 4-39, A-6
      - 1Ah, 4-39, A-6
      - 1Bh, 4-40, A-6
      - 1C-1Fh, 4-41, A-6
      - 20h, 4-42, A-6
      - 21h, 4-42, A-6
      - 22h, 4-43, A-6
      - 23h, 4-44, A-6
      - 24-26h, 4-45, A-7
      - 27h, 4-45, A-7
      - 28-2Bh, 4-46, A-7
      - 2C-2Fh, 4-46, A-7
      - 30-33h, 4-47, A-7
      - 34-37h, 4-47, A-7
      - 38h, 4-48, A-7
      - 39h, 4-49, A-7
      - 3Ah, 4-50, A-7
      - 3Bh, 4-51, A-7
      - 3C-3Fh, 4-53, A-7
      - 40h, 4-53, A-8
      - 41h, 4-55, A-8
      - 42h, 4-55, A-8
      - 43h, 4-57, A-8
      - 44h, 4-58, A-8
      - 45h, 4-59, A-8
      - 46h, 4-59, A-8
      - 47h, 4-60, A-8
      - 48h, 4-60, A-9
      - 49h, 4-61, A-9
      - 4Ah, 4-62, A-9
      - 4Bh, 4-62, A-9
      - 4Ch, 4-63, A-9
      - 4Dh, 4-64, A-9
      - 4Eh, 4-65, A-9
      - 4Fh, 4-66, A-10
      - 50-51h, 4-68, A-10
      - 54-55h, 4-68, A-10
      - 58-59h, 4-69, A-10
      - 5C-5Fh, 4-69, A-10
      - 60-70h, 4-70, A-10
    - register bits
      - 53C700 Compatibility, 4-51, A-7
      - Abort Operation, 4-36, A-5
      - Aborted, 4-32, 4-49, A-5, A-7
      - Always Wide SCSI, 4-65, A-9
      - Arbitration in Progress, 4-33, A-5
      - Arbitration Mode, 4-20, A-3
      - Arbitration Priority Encoder Test, 4-63, A-9
      - Assert Even SCSI Parity (force bad parity)), 4-22, A-3
      - Assert SATN/ on Parity Error, 4-21, A-3
      - Assert SCSI ACK/ Signal, 4-30, A-4
      - Assert SCSI ATN/ Signal, 4-30, A-4
      - Assert SCSI BSY/ Signal, 4-30, A-4

- Assert SCSI C\_D/ Signal, 4-30, A-4
- Assert SCSI Data Bus, 4-22, A-3
- Assert SCSI I\_O/ Signal, 4-30, A-4
- Assert SCSI MSG/ Signal, 4-30, A-4
- Assert SCSI REQ/ Signal), 4-30, A-4
- Assert SCSI RST/ Signal, 4-22, A-3
- Assert SCSI SEL/ Signal, 4-30, A-4
- Burst Disable, 4-42, A-6
- Burst Length, 4-44, 4-48, A-6, A-7
- Burst Op Code Fetch Enable, 4-48, A-7
- Bus Fault, 4-31, 4-49, A-5, A-7
- Byte Empty in DMA FIFO, 4-39, A-6
- Byte Full in DMA FIFO, 4-39, A-6
- Byte Offset Counter, 4-42, 4-44, A-6
- Cache Line Size Enable, 4-51, A-7
- Chained Mode, 4-24, A-3
- Chip Revision Level, 4-40, A-6
- Chip Type, 4-59, A-8
- Clear DMA FIFO, 4-40, A-6
- Clear SCSI FIFO, 4-66, A-10
- Clock Address Incrementor, 4-43, A-6
- Clock Byte Counter, 4-43, A-6
- Clock Conversion Factor, 4-26, A-3
- Configured as I/O, 4-39, A-6
- Configured as Memory, 4-39, A-6
- Connected, 4-22, 4-37, A-3, A-5
- Data Acknowledge Status, 4-40, A-6
- Data Request Status, 4-40, A-6
- Data Transfer Direction, 4-39, A-6
- Destination I/O-Memory Enable, 4-48, A-7
- Disable Halt on Parity Error or ATN, 4-22, A-3
- Disable Single Initiator Response, 4-66, A-10
- DMA Direction, 4-44, A-6
- DMA FIFO, 4-44, A-6
- DMA FIFO Empty, 4-31, A-5
- DMA Interrupt Pending, 4-38, A-5
- Enable Parity Checking, 4-21, A-3
- Enable Read Line, 4-48, A-7
- Enable Read Multiple, 4-48, A-7
- Enable Response to Reselection, 4-26, A-4
- Enable Response to Selection, 4-26, A-4
- Enable Wide SCSI, 4-26, A-3
- Encoded Chip SCSI ID, bits 3-0, 4-26, A-4
- Encoded Destination SCSI ID, 4-28, 4-30, A-4
- Extend SREQ/SACK Filtering, 4-65, A-9
- Extra clock cycle of data setup, 4-22, A-3
- Fetch Enable, 4-60, A-8
- Fetch Pin Mode, 4-41, A-6
- FIFO Byte Control, 4-43, A-6
- FIFO Flags, 4-34, 4-35, A-5
- Flush DMA FIFO, 4-40, A-6
- Function Complete, 4-53, 4-55, A-8
- General Purpose Timer Expired, 4-55, 4-57, A-8
- General Purpose Timer Period, 4-61, A-9
- General Purpose Timer Scale Factor, 4-61, A-9
- GPIO Enable, 4-60, A-8
- GPIO4-0, 4-29, A-4
- Halt SCSI Clock, 4-66, A-10
- Handshake-to-Handshake Timer Bus Activity Enable, 4-61, A-9
- Handshake-to-Handshake Timer Expired, 4-55, 4-57, A-8
- Handshake-to-Handshake Timer Period, 4-60, A-9
- High Impedance Mode, 4-42, A-6
- Illegal Instruction Detected, 4-32, A-5
- Illegal instruction detected, 4-50, A-7
- Immediate Arbitration, 4-23, A-3
- Interrupt on the Fly, 4-37, A-5
- IRQ Disable, 4-51, A-7
- Last Disconnect, 4-35, A-5
- Latched SCSI Parity, 4-34, A-5
- Latched SCSI Parity for SD15-8, 4-35, A-5
- Lost Arbitration, 4-33, A-5
- Manual Start Mode, 4-49, A-7
- Master Control for Set or Reset Pulses, 4-43, A-6
- Master Data Parity Error, 4-31, 4-49, A-5, A-7
- Master Enable, 4-60, A-8
- Master Parity Error Enable, 4-43, A-6
- Max SCSI Synchronous Offset, 4-28, A-4



- Parity Error, 4-56, A-8
- Phase Mismatch, 4-55, A-8
- Pre-fetch Enable, 4-51, A-7
- Pre-fetch Flush, 4-51, A-7
- Reselected, 4-53, 4-56, A-8
- Reset SCSI Offset, 4-65, A-9
- SACK/ Status, 4-31, A-4
- SATN/ Status, 4-31, A-4
- SBSY/ Status, 4-31, A-4
- SC\_D/ Status, 4-31, A-4
- SCRIPTS Interrupt Instruction Received, 4-32, A-5
- SCRIPTS interrupt instruction received, 4-49, A-7
- SCSI C\_D/ Signal, 4-34, A-5
- SCSI Control Enable, 4-65, A-9
- SCSI Data High Impedance, 4-42, A-6
- SCSI Disconnect Unexpected, 4-24, A-3
- SCSI FIFO Test Read, 4-66, A-10
- SCSI FIFO Test Write, 4-67, A-10
- SCSI Gross Error, 4-54, 4-56, A-8
- SCSI High-Impedance Mode, 4-65, A-9
- SCSI I\_O/ Signal, 4-34, A-5
- SCSI Interrupt Pending, 4-37, A-5
- SCSI Loopback Mode, 4-65, A-9
- SCSI Low level Mode, 4-65, A-9
- SCSI MSG/ Signal, 4-34, A-5
- SCSI Parity Error, 4-54, A-8
- SCSI Phase Mismatch - Initiator Mode, 4-53, A-8
- SCSI Reset Condition, 4-54, A-8
- SCSI RST/ Received, 4-56, A-8
- SCSI RST/ Signal, 4-33, A-5
- SCSI SDP0/ Parity Signal, 4-33, A-5
- SCSI SDP1 Signal, 4-35, A-5
- SCSI Selected As ID, 4-63, A-9
- SCSI Synchronous Offset Maximum, 4-63, A-9
- SCSI Synchronous Offset Zero, 4-63, A-9
- SCSI Synchronous Transfer Period, 4-27, A-4
- SCSI True End of Process, 4-40, A-6
- SCSI Valid, 4-30, A-4
- Select with SATN/ on a Start Sequence, 4-21, A-3
- Selected, 4-53, 4-56, A-8
- Selection or Reselection Time-out, 4-55, 4-57, A-8
- Selection Response Logic Test, 4-63, A-9
- Selection Time-Out, 4-61, A-9
- Semaphore, 4-37, A-5
- Shadow Register Test Mode, 4-42, A-6
- SI\_O/ Status, 4-31, A-4
- SIDL Least Significant Byte Full, 4-33, A-5
- SIDL Most Significant Byte Full, 4-35, A-5
- Signal Process, 4-37, 4-39, A-5, A-6
- Single Step Interrupt, 4-32, A-5
- Single-step Interrupt, 4-49, A-7
- Single-step Mode, 4-51, A-7
- SLPAR High Byte Enable, 4-24, A-3
- SLPAR Mode, 4-24, A-3
- SMSG/ Status, 4-31, A-4
- SODL Least Significant Byte Full, 4-33, A-5
- SODL Most Significant Byte Full, 4-35, A-5
- SODR Least Significant Byte Full, 4-33, A-5
- SODR Most Significant Byte Full, 4-35, A-5
- Software Reset, 4-36, A-5
- Source I/O-Memory Enable, 4-48, A-7
- SREQ/ Status, 4-31, A-4
- SSEL/ Status, 4-31, A-4
- Start DMA Operation, 4-51
- Start SCSI Transfer, 4-23, A-3
- Start Sequence, 4-20, A-3
- Synchronous Clock Conversion Factor, 4-25, A-3
- Target Mode, 4-21, A-3
- Timer Test Mode, 4-66, A-10
- TolerANT Enable, 4-66, A-10
- Ultra SCSI Enable, 4-25, A-3
- Unexpected Disconnect, 4-54, 4-56, A-8
- Wide SCSI Receive, 4-25, A-3
- Wide SCSI Send, 4-24, A-3
- Won Arbitration, 4-33, A-5
- Write and Invalidate Enable, 4-41, A-6
- Registers, 2-22
  - see operating registers

Reliability, 1-5  
 REQ/, 3-8  
 REQ/ - GNT/, 1-1, 2-2  
 Request, 3-8  
 Reselected bit, 4-53, 4-56, A-8  
 Reserved Command, 2-4  
 Reset, 3-5  
 Reset SCSI Offset bit, 4-65, A-9  
 RESPID0 register, 4-62, A-9  
 RESPID1 register, 4-62, A-9  
 Response ID One register, 4-62, A-9  
 Response ID Zero register, 4-62, A-9  
 Revision Level bits, 4-40, A-6  
 ROM, 3-15  
 ROM Base Address Register, 2-28  
 ROM interface, 2-28  
 ROM pin, 2-28  
 ROM/Flash Interface Pins, 3-15  
 RST/, 3-5  
 RSTDIR, 3-13, 3-14

**S**

SACK, 2-24  
 SACK/, 3-12  
 SACK/ Status bit, 4-31, A-4  
 SATN/, 3-12  
 SATN/ Active, 4-55, A-8  
 SATN/ Active bit, 4-55, A-8  
 SATN/ Status bit, 4-31, A-4  
 SBCL register, 4-31, A-4  
 SBDL register, 4-69, A-10  
 SBSY Status bit, 4-31, A-4  
 SBSY/, 3-12  
 SC\_D/, 3-12  
 SC\_D/ Status bit, 4-31, A-4  
 scatter/gather, 1-5  
 SCF2 – 0, 2-20  
 SCID register, 4-26, A-4  
 SCLK, 3-11  
 SCNTL0 register, 4-20, A-3  
 SCNTL1 Register, 2-11  
 SCNTL1 register, 4-22, A-3  
 SCNTL2 register, 4-24, A-3  
 SCNTL3 Register, 2-20

SCNTL3 register, 4-25, A-3  
 SCRATCHA register, 4-47, A-7  
 SCRATCHB register, 4-69, A-10  
 SCRIPT RAM, 2-3  
 SCRIPTS instruction, 2-25  
 SCRIPTS Interrupt Instruction Received bit, 4-32, A-5  
 SCRIPTS Processor, 2-8  
 SCRIPTS processor  
   instruction prefetching, 2-9  
   internal RAM for instruction storage, 2-9  
   performance, 2-9  
 SCRIPTS RAM, 2-9  
 Scripts RAM Disable, 3-18  
 SCSI  
   differential mode, 2-16  
   termination, 2-19  
   TolerANT technology, 1-4  
 SCSI ATN Condition - Target Mode, 4-53, A-8  
 SCSI ATN Condition bit, 4-53, A-8  
 SCSI Bus Control Lines register, 4-31, A-4  
 SCSI Bus Data Lines register, 4-69, A-10  
 SCSI bus interface, 2-16-??  
 SCSI C\_D/ Signal bit, 4-34, A-5  
 SCSI Chip ID register, 4-26, A-4  
 SCSI Clock, 3-11, 3-13, 3-14  
 SCSI Control, 3-12, 3-13, 3-14  
 SCSI Control Enable bit, 4-65, A-9  
 SCSI Control One register, 4-22, A-3  
 SCSI Control Three register, 4-25, A-3  
 SCSI Control Two register, 4-24, A-3  
 SCSI Control Zero register, 4-20, A-3  
 SCSI Controller, 2-8  
 SCSI core, 1-3  
 SCSI Data High impedance bit, 4-42, A-6  
 SCSI Destination ID register, 4-28, A-4  
 SCSI Disconnect Unexpected bit, 4-24, A-3  
 SCSI FIFO Test Read bit, 4-66, A-10  
 SCSI FIFO Test Write bit, 4-67, A-10  
 SCSI First Byte Received register, 4-29, A-4  
 SCSI Gross Error bit, 4-54, 4-56, A-8  
 SCSI High-Impedance Mode bit, 4-65, A-9  
 SCSI I\_O/ Signal bit, 4-34, A-5

- SCSI Input Data Latch register, 4-68, A-10
- SCSI instructions
  - block move, 5-3
  - I/O, 5-7
  - load/store, 5-22
  - memory move, 5-20
  - read/write, 5-12
  - transfer control, 5-15
- SCSI Interrupt Enable One register, 4-55, A-8
- SCSI Interrupt Enable Zero register, 4-53, A-8
- SCSI Interrupt Pending bit, 4-37, A-5
- SCSI Interrupt Status One register, 4-57, A-8
- SCSI Interrupt Status Zero register, 4-55, A-8
- SCSI interrupts, 2-24
- SCSI Longitudinal Parity register, 4-58, A-8
- SCSI Loopback Mode bit, 4-65, A-9
- SCSI Low Level Mode bit, 4-65, A-9
- SCSI MSG/ Signal bit, 4-34, A-5
- SCSI Output Control Latch register, 4-30, A-4
- SCSI Output Data Latch register, 4-68, A-10
- SCSI Parity Control, 2-12
- SCSI Parity Error bit, 4-54, A-8
- SCSI Performance, 1-5
- SCSI Phase Mismatch bit, 4-53, A-8
- SCSI Reset Condition bit, 4-54, A-8
- SCSI RST/ Received bit, 4-56, A-8
- SCSI RST/ Signal bit, 4-33, A-5
- SCSI SCRIPTS, 1-3
- SCSI SCRIPTS operation, 5-1
  - sample instruction, 5-2
- SCSI SDP0/ Parity Signal bit, 4-33, A-5
- SCSI SDP1 Signal bit, 4-35, A-5
- SCSI Selected As ID bits, 4-63, A-9
- SCSI Selector ID register, 4-30, A-4
- SCSI Serial EEPROM Access, 2-29
- SCSI Status One register, 4-34, A-5
- SCSI Status Two register, 4-35, A-5
- SCSI Status Zero register, 4-33, A-5
- SCSI Synchronous Offset Maximum, 4-63, A-9
- SCSI Synchronous Offset Zero bit, 4-63, A-9
- SCSI Test One register, 4-64, A-9
- SCSI Test Three register, 4-66, A-10
- SCSI Test Two register, 4-65, A-9
- SCSI Test Zero register, 4-63, A-9
- SCSI Timer One register, 4-61, A-9
- SCSI Timer Zero register, 4-60, A-9
- SCSI Transfer register, 4-27, A-4
- SCSI True End of Process bit, 4-40, A-6
- SCSI Valid bit, 4-30, A-4
- SCSI Wide Residue register, 4-59, A-8
- SCTRL/, 3-12, 3-13, 3-14
- SD/(15-0), 3-11, 3-13, 3-14
- SDID register, 4-28, A-4
- SDIR, 3-13
- SDIR(15-0), 3-13
- SDMS, 1-3
- SDP/(1-0), 3-11
- SEL, 2-23
- Select with SATN/ on a Start Sequence bit, 4-21, A-3
- Selected bit, 4-53, 4-56, A-8
- Selection of Cache Line Size, 2-7
- Selection or Reselection Time-out bit, 4-55, 4-57, A-8
- Selection Response Logic Test bits, 4-63, A-9
- Semaphore bit, 4-37, A-5
- Serial EEPROM data format, 2-29, 2-30
- Serial EEPROM Interface, 2-29
  - Mode A Operation, 2-29
  - Mode B Operation, 2-30
  - Mode C Operation, 2-30
  - Mode D Operation, 2-31
  - Register 2Ch, 4-9
  - Register 2Eh, 4-10
- SERR/, 3-8
- SFBR register, 4-29, A-4
- Shadow Register Test Mode bit, 4-42, A-6
- SI\_O/, 3-12
- SI\_O/ Status bit, 4-31, A-4
- SID, 2-29, 2-30
- SIDL Least Significant Byte Full bit, 4-33, A-5
- SIDL Most Significant Byte Full bit, 4-35, A-5
- SIDL register, 4-68, A-10
- SIEN0, 2-22
- SIEN0 register, 4-53, A-8
- SIEN1, 2-22

- SIEN1 register, 4-55, A-8
  - SIGP bit, 4-37, 4-39, A-5, A-6
  - Single Step Interrupt bit, 4-32, A-5
  - single-ended operation, 2-16
  - Single-step Interrupt bit, 4-49, A-7
  - Single-step Mode bit, 4-51, A-7
  - SIP, 2-22, 2-24
  - SIST0, 2-22, 2-24, 2-25
  - SIST0 register, 4-55, A-8
  - SIST1, 2-22, 2-24, 2-25
  - SIST1 register, 4-57, A-8
  - Slow ROM pin, 3-18
  - SLPAR High Byte Enable, 4-24, A-3
  - SLPAR Mode bit, 4-24, A-3
  - SLPAR register, 4-58, A-8
  - SMSG/, 3-12
  - SMSG/ Status bit, 4-31, A-4
  - SOCL Least Significant Byte Full bit, 4-33, A-5
  - SOCL register, 4-30, A-4
  - SODL Most Significant Byte Full bit, 4-35, A-5
  - SODL Register, 2-25, 2-26
  - SODL register, 4-68, A-10
  - SODR Least Significant Byte Full bit, 4-33, A-5
  - SODR Most Significant Byte Full bit, 4-35, A-5
  - Software Reset bit, 4-36, A-5
  - Source I/O-Memory Enable bit, 4-48, A-7
  - Special Cycle Command, 2-4
  - SREQ, 2-24
  - SREQ/, 3-12
  - SREQ/ Status bit, 4-31, A-4
  - SRST/, 3-12
  - SSEL/, 3-12
  - SSEL/ Status bit, 4-31, A-4
  - SSID register, 4-30, A-4
  - SSTAT0 register, 4-33, A-5
  - SSTAT1 register, 4-34, A-5
  - SSTAT2 register, 4-35, A-5
  - Stacked Interrupts, 2-24
  - Start DMA Operation bit, 4-51
  - Start SCSI Transfer, 4-23, A-3
  - Start Sequence bit, 4-20, A-3
  - STEST0 register, 4-63, A-9
  - STEST1 register, 4-64, A-9
  - STEST2 Register, 2-10
  - STEST2 register, 4-65, A-9
  - STEST3 register, 4-66, A-10
  - STIME0 register, 4-60, A-9
  - STIME1 register, 4-61, A-9
  - Stop, 3-7
  - Subsystem ID, 2-29, 2-30
  - Subsystem Vendor ID, 2-29, 2-30
  - SVID, 2-29, 2-30
  - SWIDE Register, 2-25, 2-26
  - SWIDE register, 4-59, A-8
  - SXFER Register, 2-20
  - SXFER register, 4-27, A-4
  - SYM53C876 Benefits, 1-5
  - SYM53C876 Functional Signal Grouping, 3-3
  - SYM53C876 Host Interface SCSI Data Paths, 2-16
  - Synchronous Clock Conversion Factor bits, 4-25, A-3
  - Synchronous data transfer rates, 2-20
  - Synchronous Operation, 2-19
  - Synchronous SCSI Receive, 2-16
  - Synchronous SCSI Send, 2-15
  - Synchronous Transfer Period bits, 4-27, A-4
  - System Pins, 3-5
- T**
- Target Mode bit, 4-21, A-3
  - Target Ready, 3-7
  - TCK, 3-16
  - TDI, 3-16
  - TDO, 3-16
  - TEMP register, 4-41, A-6
  - Temporary register, 4-41, A-6
  - termination, 2-19
  - Terminator Networks, 2-19
  - Testability, 1-5
  - TESTIN/, 3-16
  - TGS, 3-13, 3-14
  - Timer Test Mode bit, 4-66, A-10
  - Timing Diagrams, 6-16
  - timings
    - Ultra SCSI, 6-58
  - TMS, 3-16

- TolerANT Enable bit, 2-21, 4-66, A-10
  - TolerANT SCSI, 1-4
  - TolerANT Technology, 1-4
    - benefits, 1-4
    - electrical characteristics, 6-9
    - Extend SREQ/SACK Filtering bit, 4-65, A-9
    - TolerANT Enable bit, 4-66, A-10
  - TolerANT technology, 1-6
  - Totem Pole Output, 3-4
  - TP2 – 0, 2-20
  - Transfer Control Instructions, 5-15
    - and SCRIPTS instruction prefetching, 2-10
  - transfer rate
    - synchronous, 2-20
  - TRDY/, 3-7
  - Tri-State, 3-4
  - Typical SYM53C876 Board Application, 1-3
  - Typical SYM53C876 System Application, 1-2
- U**
- Ultra SCSI, 1-1, 1-3
    - Clock Conversion Factor bits, 4-26
    - Synchronous Transfer Period bits, 4-27
    - timings, 6-58
    - Ultra SCSI Enable bit, 4-25, A-3
  - Ultra SCSI Enable bit, 4-25, A-3
  - Ultra SCSI Synchronous Data Transfers, 2-20
  - Unexpected Disconnect bit, 4-54, 4-56, A-8
- V**
- VDD, 3-17
  - VDD-C, 3-17
  - VDD-IO, 3-17
  - VSS, 3-17
  - VSS-C, 3-17
  - VSS-S, 3-17
- W**
- WATN/ bit, 4-21, A-3
  - wide SCSI
    - Always Wide SCSI bit, 4-65, A-9
    - chained block moves, 2-25
    - Chained Mode bit, 4-24, A-3
    - Enable Wide SCSI bit, 4-26, A-3
    - SWIDE register, 4-59, A-8
    - Wide SCSI Receive bit, 4-25, A-3
    - Wide SCSI Send bit, 4-24, A-3
    - Wide SCSI Receive bit, 4-25, A-3
    - Wide SCSI Send bit, 4-24, A-3
    - Wide Ultra SCSI, 1-3
    - Wide Ultra SCSI Benefits, 1-3
    - Wide Ultra SCSI Enable bit, 2-21
    - Wide Ultra SCSI Mode Enable bit, 2-20
    - Wide Ultra SCSI Synchronous Data Transfers, 2-20
    - Won Arbitration bit, 4-33, A-5
    - Write and Invalidate Enable bit, 4-41, A-6
    - WSR bit, 2-25
    - WSS flag, 2-25