

MITSUBISHI RF POWER TRANSISTOR 2SC2056

NPN EPITAXIAL PLANAR TYPE

DESCRIPTION

2SC2056 is a silicon NPN epitaxial planar type transistor designed for RF power amplifiers in VHF band portable or hand-held radio applications.

FEATURES

- High power gain: $G_{pe} \geq 9\text{dB}$
@ $V_{CC} = 7.2\text{V}$, $P_O = 1.6\text{W}$, $f = 175\text{MHz}$
- TO-39 metal sealed package for high reliability.
- Emitter ballasted construction, gold metallization for good performances.
- Emitter electrode is connected electrically to the case.

APPLICATION

1 to 1.5 watt power amplifiers in VHF band portable or hand-held radio applications.

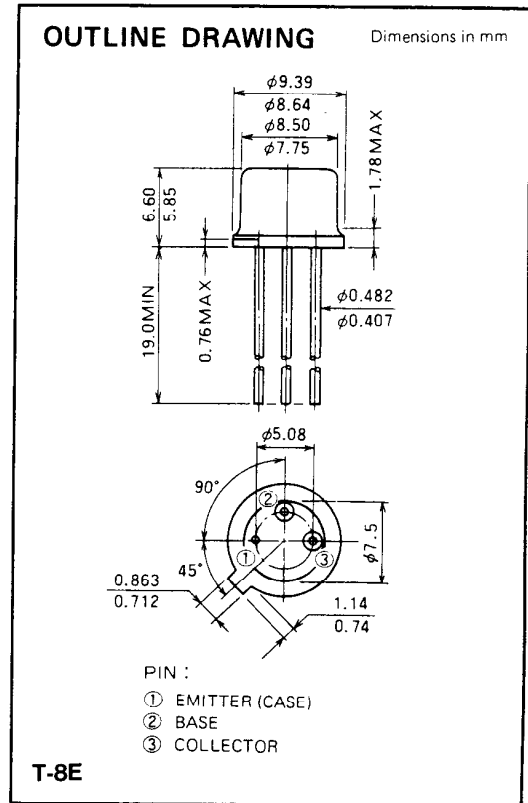

ABSOLUTE MAXIMUM RATINGS ($T_C = 25^\circ\text{C}$ unless otherwise specified)

Symbol	Parameter	Conditions	Ratings	Unit
V_{CB0}	Collector to base voltage		18	V
V_{EB0}	Emitter to base voltage		4	V
V_{CE0}	Collector to emitter voltage	$R_{BE} = \infty$	9	V
I_C	Collector current		0.6	A
P_C	Collector dissipation	$T_a = 25^\circ\text{C}$	0.8	W
		$T_C = 25^\circ\text{C}$	4	W
T_j	Junction temperature		175	$^\circ\text{C}$
T_{stg}	Storage temperature		-55 to 175	$^\circ\text{C}$
R_{th-a}	Thermal resistance	Junction to ambient	187.5	$^\circ\text{C/W}$
R_{th-c}		Junction to case	37.5	$^\circ\text{C/W}$

Note. Above parameters are guaranteed independently.

ELECTRICAL CHARACTERISTICS ($T_C = 25^\circ\text{C}$ unless otherwise specified)

Symbol	Parameter	Test conditions	Limits			Unit
			Min	Typ	Max	
$V_{(BR)EBO}$	Emitter to base breakdown voltage	$I_E = 1\text{mA}$, $I_C = 0$	4			V
$V_{(BR)CBO}$	Collector to base breakdown voltage	$I_C = 10\text{mA}$, $I_E = 0$	18			V
$V_{(BR)CEO}$	Collector to emitter breakdown voltage	$I_C = 10\text{mA}$, $R_{BE} = \infty$	9			V
I_{CBO}	Collector cutoff current	$V_{CB} = 10\text{V}$, $I_E = 0$			100	μA
I_{EBO}	Emitter cutoff current	$V_{EB} = 3\text{V}$, $I_C = 0$			100	μA
h_{FE}	DC forward current gain *	$V_{CE} = 7\text{V}$, $I_C = 0.1\text{A}$	10	50	180	—
* P_O	Output power	$V_{CC} = 7.2\text{V}$, $P_{in} = 0.2\text{W}$, $f = 175\text{MHz}$	1.6	2		W
η_C	Collector efficiency		55	60		%

Note. * Pulse test, $P_W = 150\mu\text{s}$, duty = 5%.
 Above parameters, ratings, limits and conditions are subject to change.

NPN EPITAXIAL PLANAR TYPE

TEST CIRCUIT

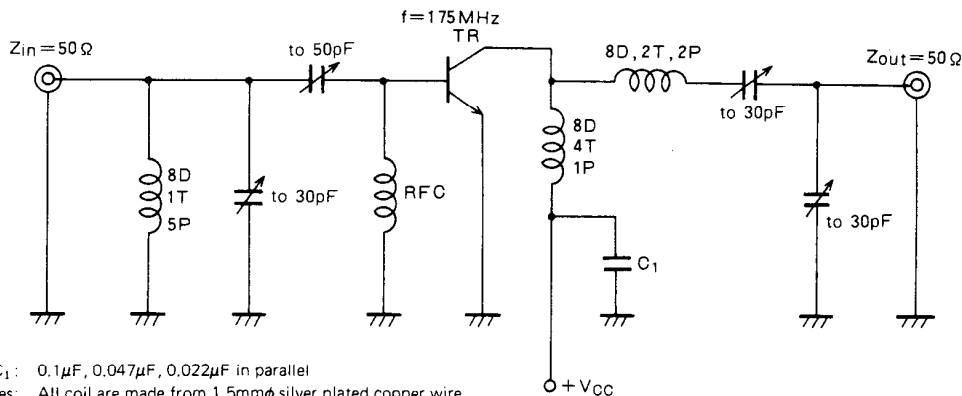

C_1 : 0.1 μ F, 0.047 μ F, 0.022 μ F in parallel
 Notes: All coils are made from 1.5mm ϕ silver plated copper wire
 Coil dimensions in milli-meter
 D: Inner diameter of coil
 T: Turn number of coil
 P: Pitch of coil

TYPICAL PERFORMANCE DATA

COLLECTOR DISSIPATION VS. AMBIENT TEMPERATURE

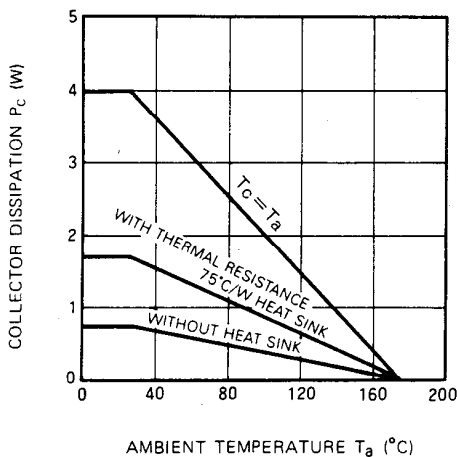

THERMAL RESISTANCE 75°C/W HEAT SINK OUTLINE DRAWING

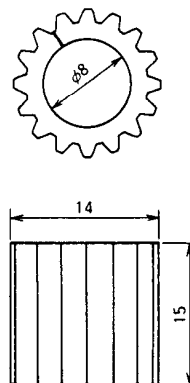

MATERIAL: A2
 DIMENSIONS: mm

COLLECTOR CURRENT VS. COLLECTOR TO EMITTER VOLTAGE

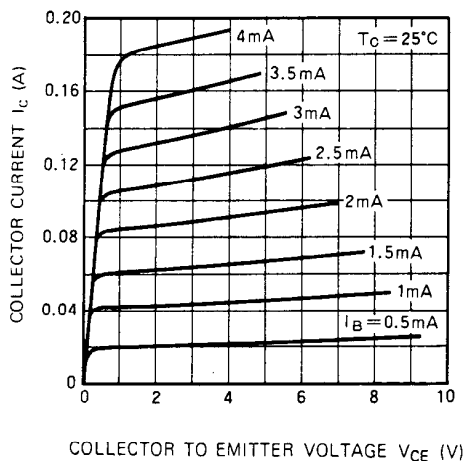

DC CURRENT GAIN VS. COLLECTOR CURRENT

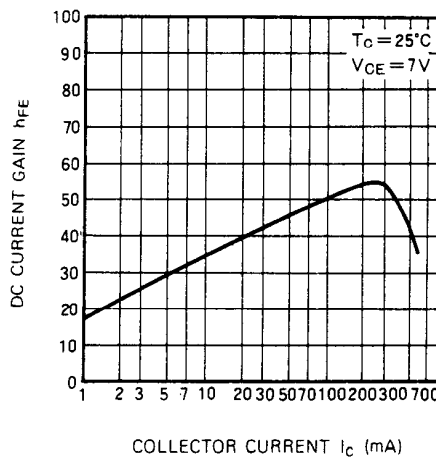

NPN EPITAXIAL PLANAR TYPE

COLLECTOR TO EMITTER BREAKDOWN VOLTAGE VS. BASE TO EMITTER RESISTANCE

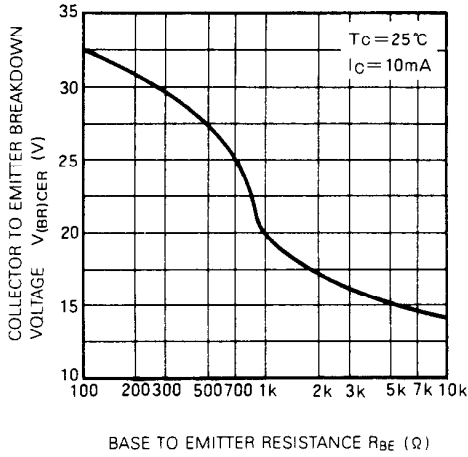

COLLECTOR OUTPUT CAPACITANCE VS. COLLECTOR TO BASE VOLTAGE CHARACTERISTICS

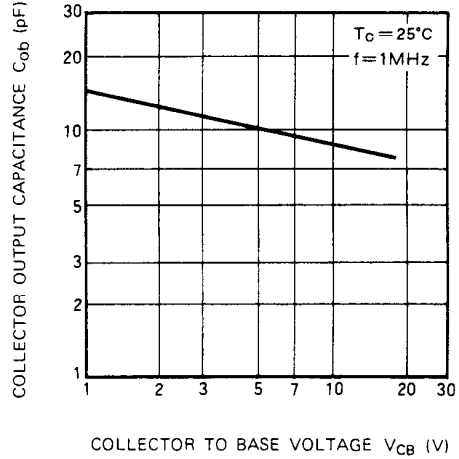

OUTPUT POWER, COLLECTOR EFFICIENCY VS. INPUT POWER

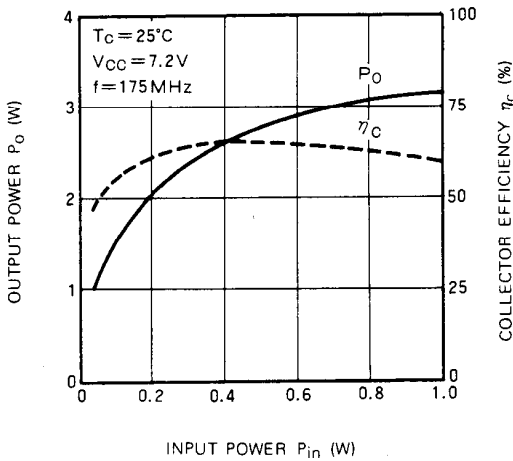

OUTPUT POWER VS. COLLECTOR SUPPLY VOLTAGE

