

GENERAL DESCRIPTION

The BL8531H_ADC is a CMOS 12bit analog-to-digital converter (ADC). It converts the analog input signal into 12bit binary digital codes at a maximum sampling rate of 10MHz.

The device is a monolithic ADC with an on-chip, high-performance, sample-and-hold Amplifier (SHA) and current referenc. The structure allows both differential and single-ended input.

This 12bit ADC has also 3 channel MUX, so 3 channel inputs are acceptable.

TYPICAL APPLICATIONS

CCD Imaging (Copiers, Scanners, Cameras)

Medical Instruments

Digital Communication Systems

FEATURES

- Resolution : 12bit
- Maximum Conversion Rate : 10MHz
- Power Supply : 5V
- Power Consumption : 100mW (typical)
- Reference Voltage : 3.5V, 1.5V (dual reference)
- Input Range : 0.5V ~ 4.5V (4.0V_{P-P})
- Differential Linearity Error : ± 0.7 LSB
- Integral Linearity Error : ± 1.0 LSB
- Signal to Noise & Distortion Ratio : 65dB
- Total Harmonic Distortion : 74dB
- 3 Channel Inputs
- Digital Output : CMOS Level
- Operating Temperature Range : 0°C ~ 70°C

FUNCTIONAL BLOCK DIAGRAM

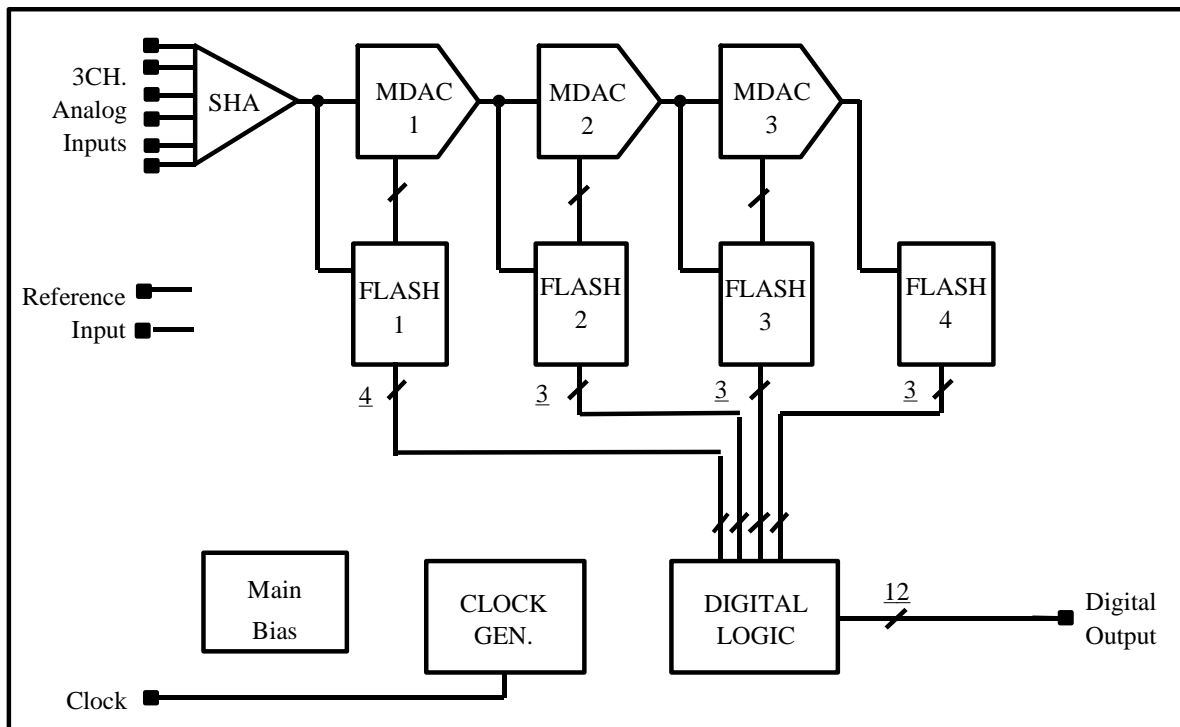

Ver 1.1 (Apr. 2002)

No responsibility is assumed by SEC for its use nor for any infringements of patents or other rights of third parties that may result from its use. The content of this datasheet is subject to change without any notice.

CORE PIN DESCRIPTION

NAME	I/O TYPE	I/O PAD	PIN DESCRIPTION
REFTOP	AO	poar10_bb	Reference Top Force (3.5V)
REFBOT	AO	poar10_bb	Reference Bottom Force (1.5V)
CML	AO	poar10_bb	Internal Bias
VDDA	AP	vdda	Analog Power (5V)
VBB	AG	vbba	Analog Sub Bias
VSSA	AG	vssa	Analog Ground
R_INP	AI	piar10_bb	Analog Input (RED) + (Input Range : 1.5V ~ 3.5V)
R_INN	AI	piar10_bb	Analog Input (RED) - (Input Range : 1.5V ~ 3.5V)
G_INP	AI	piar10_b	Analog Input (GREEN) + (Input Range : 1.5V ~ 3.5V)
G_INN	AI	piar10_bb	Analog Input (GREEN) - (Input Range : 1.5V ~ 3.5V)
B_INP	AI	piar10_bb	Analog Input (BLUE) + (Input Range : 1.5V ~ 3.5V)
B_INN	AI	piar10_bb	Analog Input (BLUE) - (Input Range : 1.5V ~ 3.5V)
REDB	DI	picc_bb	RED Channel Select (0:select)
GREENB	DI	picc_bb	GREEN Channel Select (0:select)
BLUEB	DI	picc_bb	BLUE Channel Select (0:select)
STBY	DI	picc_bb	VDD=power saving (standby), GND=normal
CKIN	DI	picc_bb	Sampling Clock Input
D[11:0]	DO	pot4_bb	Digital Output
VSSD	DG	vssd	Digital GND
VDDD	DP	vddd	Digital Power (5V)

I/O TYPE ABBR.

- AI : Analog Input
- DI : Digital Input
- AO : Analog Output
- DO : Analog Output
- AP : Analog Power
- AG : Analog Ground
- DP : Digital Power
- DG : Digital Ground
- AB : Analog Bidirection
- DB : Digital Bidirection

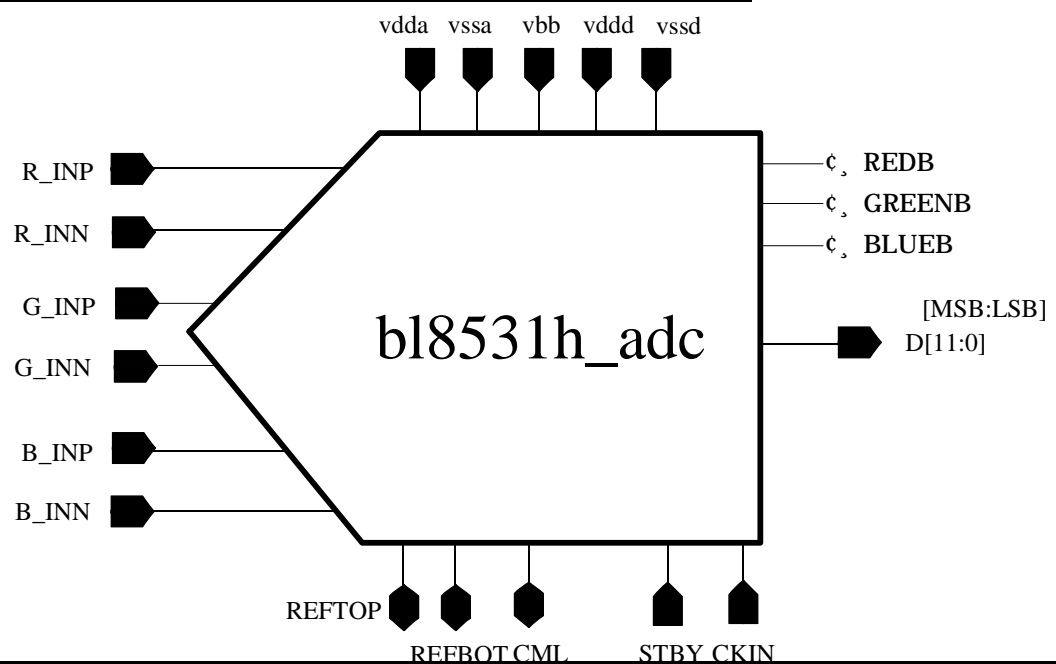

ABSOLUTE MAXIMUM RATINGS

Characteristics	Symbol	Value	Unit
Supply Voltage	VDD	6.0	V
Analog Input Voltage	R_INP/R_INN G_INP/G_INN B_INP/B_INN	VSS to VDD	V
Digital Input Voltage	CLK	VSS to VDD	V
Storage Temperature Range	Tstg	-45 to 150	°C
Operating Temperature Range	Topr	0 to 70	°C

NOTES

1. Absolute maximum rating specifies the values beyond which the device may be damaged permanently. Exposure to ABSOLUTE MAXIMUM RATING conditions for extended periods may affect reliability. Each condition value is applied with the other values kept within the following operating conditions and function operation under any of these conditions is not implied.
2. All voltages are measured with respect to VSS unless otherwise specified.
3. 100pF capacitor is discharged through a 1.5kΩ resistor (Human body model)

RECOMMENDED OPERATING CONDITIONS

Characteristics	Symbol	Min	Typ	Max	Unit
Supply Voltage	VDDA1	4.75	5.0	5.25	V
	VDDA2				
	VDDA3				
Analog Input Voltage	R_INP/G_INP/B_INP R_INN/G_INN/B_INN	0.5	- 2.5	4.5	V
Operating Temperature	Topr	0	-	70	°C

NOTES

It is strongly recommended that all the supply pins (VDDA, VDDD) be powered from the same source to avoid power latch-up.

DC ELECTRICAL CHARACTERISTICS

Characteristics	Symbol	Min	Typ	Max	Unit	Test Condition
Differential Nonlinearity	DNL	-	±0.7	±1	LSB	REFTOP=3.5V REFBOT=1.5V
Integral Nonlinearity	INL	-	±1.0	-	LSB	
Offset Voltage	OFF	-	10	-	mV	

(Converter Specifications : VDDA=VDDD=5V, VSSA=VSSD=0V,
Toper=25°C, REFTOP=3.5V, REFBOT=1.5V unless otherwise specified)

AC ELECTRICAL CHARACTERISTICS

Characteristics	Symbol	Min	Typ	Max	Unit	Test Condition
Maximum Conversion Rate	fc	-	10		MHz	AINR=R_INP-R_INN AING=G_INP-G_INN AING=B_INP-B_INN
Dynamic Supply Current	IVDD	-	20		mA	fc=10MHz (without system load)
Signal-to-Noise & Distortion Ratio	SNDR	-	65	-	dB	AIN=1MHz, Differential Input
Total Harmonic Distortion	THD	-	74	-	dB	AIN=1MHz, Differential Input

(Conversion Specifications : VDDA=VDDD=5V, VSSA=VSSD=0V,
Toper=25°C, REFTOP=3.5V, REFBOT=1.5V unless otherwise specified)

I/O CHART

Index	R_INP Input (V)	R_INN Input (v)	Digital Output	
0	0.500 ~ 0.501	2.5	0000 0000 0000	RED Channel Input Full Scale=4V 1LSB=0.977mV REFTOP=3.5V REFBOT=1.5V
1	0.501 ~ 1.502	2.5	0000 0000 0001	
2	0.502 ~ 1.503	2.5	0000 0000 0010	
i	i		i	
8197	2.499 ~ 2.5000	2.5	0111 1111 1111	
8192	2.500 ~ 2.501	2.5	1000 0000 0000	
8193	2.501 ~ 2.502	2.5	1000 0000 0001	
i	i		i	
16381	4.497 ~ 4.498	2.5	1111 1111 1101	
16382	4.498 ~ 4.499	2.5	1111 1111 1110	
16383	4.499 ~ 4.500	2.5	1111 1111 1111	

TIMING DIAGRAM

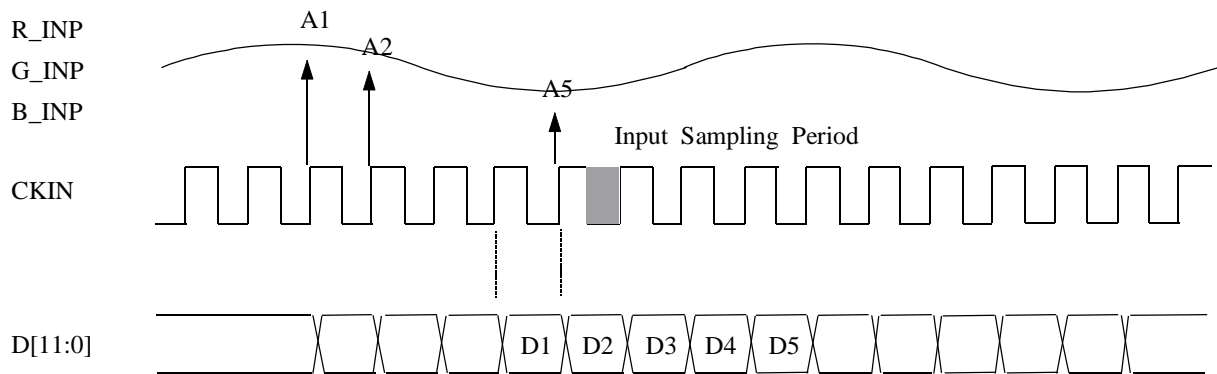

FUNCTIONAL DESCRIPTION

1. The BL8531H_ADC is a CMOS four step pipelined Analog-to-Digital Converter. It contains 4-bit flash A/D Converters, three 3bit flash A/D converters and three multiplying D/A Convertors. The N-bit flash ADC is composed of 2^N-1 latched comparators, and multiplying DAC is composed of $2*(2^N+1)$ capacitors and two fully-differential amplifiers.
2. The BL8531H_ADC operates as follows. During the first "L" cycle of external clock the analog input data is sampled, and the input is held from the rising edge of the external clock, which is fed to the first 4-bit flash ADC, and the first multiplying DAC. Multiplying DAC reconstructs a voltage corresponding to the first 4-bit ADC's output, and finally amplifies a residue voltage by 2^4 . The second and third flash ADC, and MDAC are worked as same manner. Finally amplified residue voltage at the third multiplying DAC is fed to the last 3-bit flash ADC decides final 3-bit digital code.
3. BL8531H_ADC has the error correction scheme, which handles the output from mismatch in the first, second, third and fourth flash ADC.

MAIN BLOCK DESCRIPTION**1. SHA**

SHA (Sample-and-Hold Amplifier) is the circuit that samples the analog input signal and hold that value until next sample-time. It is good as small as its different value between analog input signal and output signal. SHA amp gain is higher than 70dB at 10MHz conversion rate, its settling-time must be shorten than 38ns with less than 1/2 LSB error voltage at 12bit resolution. This SHA is consist of fully differential op amp, switching tr. and sampling capacitor. The sampling clock is non-overlapping clock (Q1, Q2) and sampling capacitor value is about 4pF. SHA uses independent bias to protect interruption of any other circuit. SHA amp is designed that open-loop dc gain is higher than 70dB, phase margin is higher than 60 degrees. Its input block is designed to be the rail-to-rail architecture using complementary different pair.

2. FLASH

The 4-bit flash converters compare analog signal (SAH output) with reference voltage, and that results transfer to MDAC and digital correction logic block. It is realized fully differential comparators of 15EA. Considering self-offset, dynamic feed through error, it should distinguish 40mV at least. First, the comparators charge the reference voltage at the sampling capacitors before transferred SHA output. That operation is performed on the phase of Q2, and discharging on the phase of Q1. That is, the comparators compare relative different values dual input voltage with dual reference voltage. Its output during Q1 operation is stored at the pre-latch block by Q1P.

3. MDAC

MDAC is the most important block at this ADC and it decides the characteristics. MDAC is consist of two stage op amp, selection logic and capacitor array (c_array). c_array's compositions are the capacitors to charge the analog input and and the reference voltage, switches to control the path. Selection logic controls the c_array internal switches. If Q1 is high, selection's output are all low, the switches of tsw1 are off, the switches of tsw2 are all on. Therefore the capacitors of c_array can charge analog input values held at SHA.

CORE EVALUATION GUIDE

1. ADC function is evaluated by external check on the bidirectional pads connected to input nodes of HOST DSP back-end circuit.
2. If User want the specific analog input range, the reference voltages may be forced.

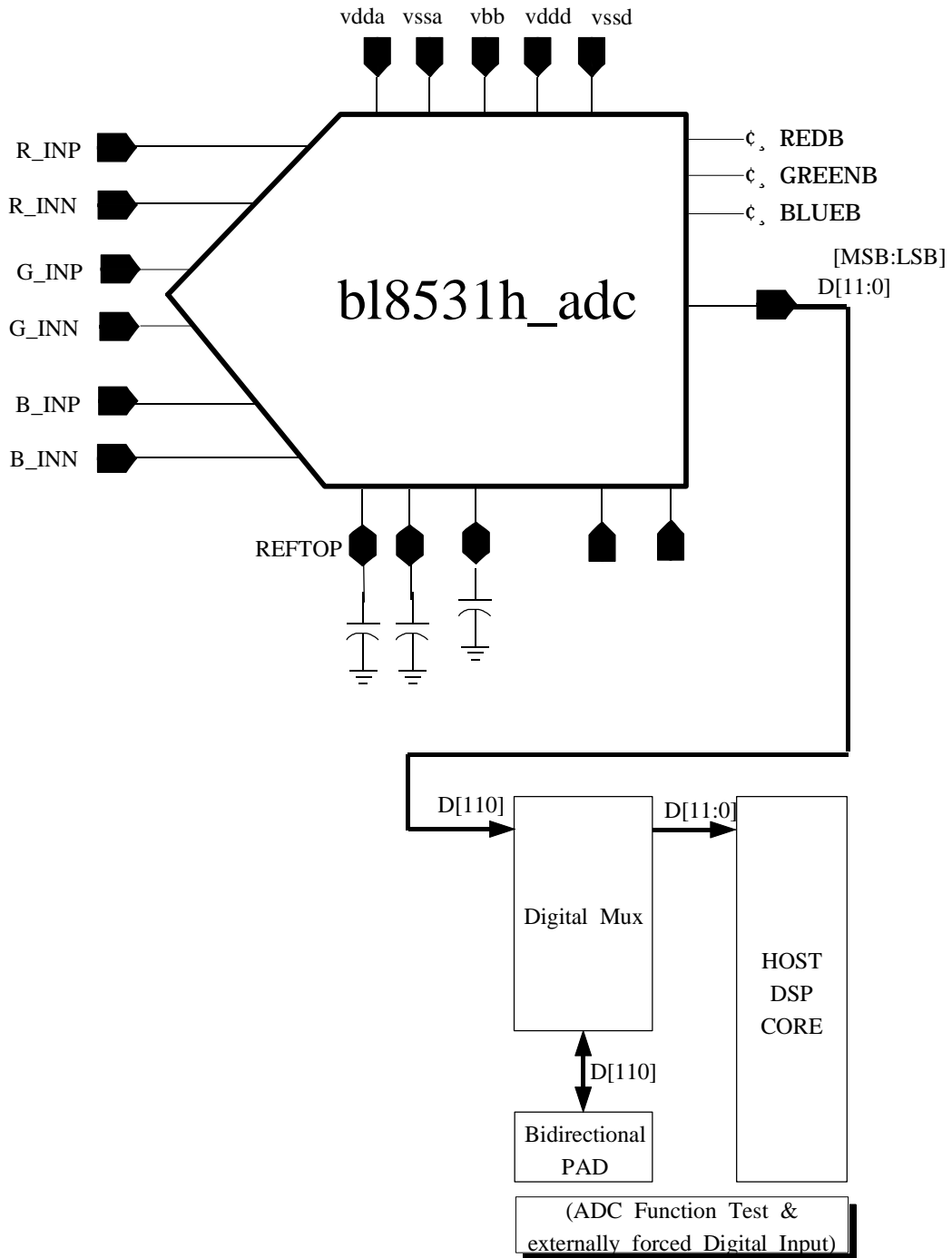

USER GUIDE

1. Input Channel Select

- REDB, GREENB, BLUEB
- only 1 channel should be selected
- for example for RED channel select : REDB=0, GREENB=1, BLUEB=1

2. Input Range (for example : RED channel)

- If you want to using the single-ended input and RED channel is selected, you should use the input range as below.
 - R_INP : 0.5V ~ 4.5V
 - R_INN : 2.5V
- If you want to using the differential input, you should use the input range as below.
 - R_INP : 1.5V ~ 3.5V,
 - R_INN : 1.5V ~ 3.5V.
 - AINR : R_INP – R_INN
- If you want to changing input range (AINR span), you can force reference voltages.
 - AIN span = –REF ~ +REF
 - REF = REFTOP – REFBOT

PHANTOM CELL INFORMATION

- Pins of the core can be assigned externally (Package pins) or internally (internal ports) depending on design methods.
- The term "External" implies that the pins should be assigned externally like power pins.
- The term "External/internal" implies that the applications of these pins depend on the user.

Pin Name	Pin Usage	Pin Layout Guide
VDDA	External	- Maintain the large width of lines as far as the pads.
VSSA	External	
VBB	External	
VDDD	External	- Do not merge the analog powers with another power from other blocks.
VSSD	External	
B_INP	External/Internal	
B_INN	External/Internal	- Use good power and ground source on board.
G_INP	External/Internal	
G_INN	External/Internal	
R_INP	External/Internal	
R_INN	External/Internal	
B_INN	External/Internal	
CKIN	External/Internal	- Do not overlap with digital lines.
REFTOP	External/Internal	- Maintain the shotest path to pads.
REFBOT	External/Internal	
STBY	External/Internal	- Separate from all other analog signals
REDB	External/Internal	
GREENB	External/Internal	
BLUEB	External/Internal	- Maintain the larger width and the shorter length as far as the pads.
DO[11]	External/Internal	
DO[10]	External/Internal	
DO[9]	External/Internal	
DO[8]	External/Internal	
DO[7]	External/Internal	
DO[6]	External/Internal	
DO[5]	External/Internal	
DO[4]	External/Internal	
DO[3]	External/Internal	
DO[2]	External/Internal	
DO[1]	External/Internal	
DO[0]	External/Internal	- Separate from all other digital lines.
DO[11]	External/Internal	- Separated from the analog clean signals if possible.
DO[10]	External/Internal	
DO[9]	External/Internal	
DO[8]	External/Internal	
DO[7]	External/Internal	
DO[6]	External/Internal	
DO[5]	External/Internal	
DO[4]	External/Internal	
DO[3]	External/Internal	
DO[2]	External/Internal	
DO[1]	External/Internal	
DO[0]	External/Internal	

FEEDBACK REQUEST

It should be quite helpful to our ADC core development if you specify your system requirements on ADC in the following characteristic checking table and fill out the additional questions.

We appreciate your interest in our products. Thank you very much.

Characteristic	Min	Typ	Max	Unit	Remarks
Analog Power Supply Voltage				V	
Digital Power Supply Voltage				V	
Bit Resolution				Bit	
Reference Input Voltage				V	
Analog Input Voltage				V _{pp}	
Operating Temperature				°C	
Integral Non-linearity Error				LSB	
Differential Non-linearity Error				LSB	
Bottom Offset Voltage Error				mV	
Top Offset Voltage Error				mV	
Maximum Conversion Rate				MSPS	
Dynamic Supply Current				mA	
Power Dissipation				mW	
Signal-to-noise Ratio				dB	
Pipeline Delay				CLK	
Digital Output Format (Provide detailed description & timing diagram)					

1. Between single input-output and differential input-output configurations, which one is suitable for your system and why?
2. Please comment on the internal/external pin configurations you want our ADC to have, if you have any reason to prefer some type of configuration.
3. Freely list those functions you want to be implemented in our ADC, if you have any.

