

4

3

2

1

This drawing involves proprietary design rights of Tyco Electronics Corporation, and all design, manufacture, reproduction, use and sale rights regarding the same are expressly reserved. It is submitted for a specific purpose and the recipient by accepting this drawing, assumes custody and control and agrees to take reasonable precautions: (a) that this drawing will not be copied and reproduced, in whole or in part, or its contents revealed in any manner, or to any person except to meet the purpose for which it was delivered and (b) that any special features peculiar to this design will not be incorporated in other projects without the expressed written permission of Tyco Electronics Corporation.

## REVISIONS

EC	REV	DESCRIPTION	DATE
CPR	A	NEW RELEASE, PREVIOUSLY CUD 499-014	03/25/06

TYPICAL SPECIFICATION TABLE

POSITION	CONTACT SIZE	RATING	NOM INSERTION FORCE	NOM EXTRACTION FORCE
39 - 40	#4	125A/250 VOLTS	3.8lbs/1.72Kg	3.0lbs/1.36Kg
7 - 38	#20	5A/250 VOLTS	.2Lbs/.09Kg	.1Lbs/.05Kg
1 - 6	#12	35A/250 VOLTS	2.9lbs/1.32Kg	1.9lbs/.86Kg

8. REFERENCE ELCON PART NUMBER 241-27-01100.

7. SEE DRAWING C-1648156 FOR MATING SOCKET CONNECTOR.

6. ITEMS PROVIDED TO THIS SPECIFICATION TO BE PERMANENTLY IDENTIFIED PER THE FOLLOWING IDENTIFIER:

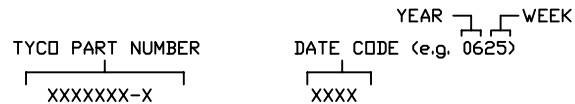

5. ALL DIMENSIONS SHOWN ACROSS A CENTERLINE ( $\phi$ ) SHALL BE CENTRALIZED WITHIN THE TOLERANCE INDICATED FOR THAT DIMENSION.

4. A REFERENCE DIMENSION (XXX) IS WITHOUT TOLERANCE AND USED FOR INFORMATION PURPOSE ONLY.

3. RECOMMENDED MOUNTING HARDWARE: TO BE ORDERED SEPARATELY.

- FOR PANEL MOUNTING, USE

1650402-1: SHOULDER SCREW, #8-32

1650106-1: SHOULDER SCREW, #6-32

1650589-1: SHOULDER SCREW, M4X0.7

- FOR PCB MOUNTING, USE COMMERCIALLY AVAILABLE SCREW AND WASHER (IF REQUIRED).

2. MATERIALS:

HOUSING: THERMOPLASTIC, GLASS REINFORCED, COLOR-BLACK  
UL94V-0 FLAMMABILITY RATED.

RETENTION CLIP: COPPER ALLOY OR STAINLESS STEEL

1. PART NUMBER CHANGES AND OR DESIGN CHANGES AFFECTING ITEM INTERCHANGEABILITY REQUIRE PRIOR TYCO APPROVAL AND AUTHORIZATION BY REVISION TO THIS DRAWING.



NOTES: UNLESS OTHERWISE SPECIFIED

1648151-1

AS SHOWN

PART NUMBER

DESCRIPTION

 THIRD ANGLE PROJECTION UNLESS OTHERWISE SPECIFIED DIMENSIONS ARE IN INCHES (METRIC) TOLERANCES ANGLES ± .5° DECIMALS .XXX ± .010 (.25) .XX ± .02 (.3)	DRAWN HA NGUYEN	DATE 03/25/06	 Tyco Electronics Corporation Menlo Park, Ca 94025 	
	CHECKED			TITLE CONNECTOR, PIN HOUSING 2X#4, 32X#20, 6X#12, FLOAT MOUNT 125A MIDDLE DRAWER
	APPROVED			SIZE DWG NUMBER B C = 1648151
	APPROVED STEVE FLICKINGER	03/25/06		REV. A
	DCA APPROVED HA NGUYEN	03/25/06		
	ACAD FILE NUMBER	C1648151A.DWG	DWG SCALE 1=1 SH 1 OF 3	

4

3

2

1

This drawing involves proprietary design rights of Tyco Electronics Corporation, and all design, manufacture, reproduction, use and sale rights regarding the same are expressly reserved. It is submitted for a specific purpose and the recipient by accepting this drawing, assumes custody and control and agrees to take reasonable precautions: (a) that this drawing will not be copied and reproduced, in whole or in part, or its contents revealed in any manner, or to any person except to meet the purpose for which it was delivered and (b) that any special features peculiar to this design will not be incorporated in other projects without the expressed written permission of Tyco Electronics Corporation.

REVISIONS			
EC	REV	DESCRIPTION	DATE
		SEE SHEET 1	

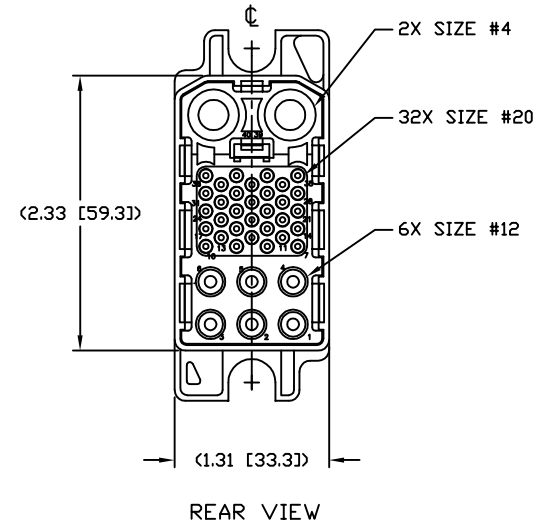
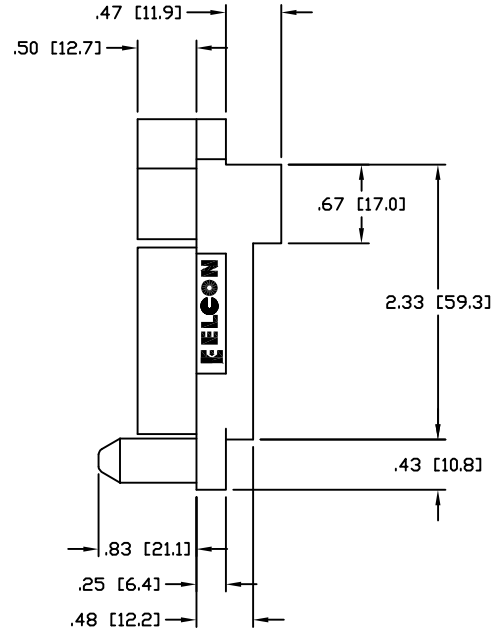
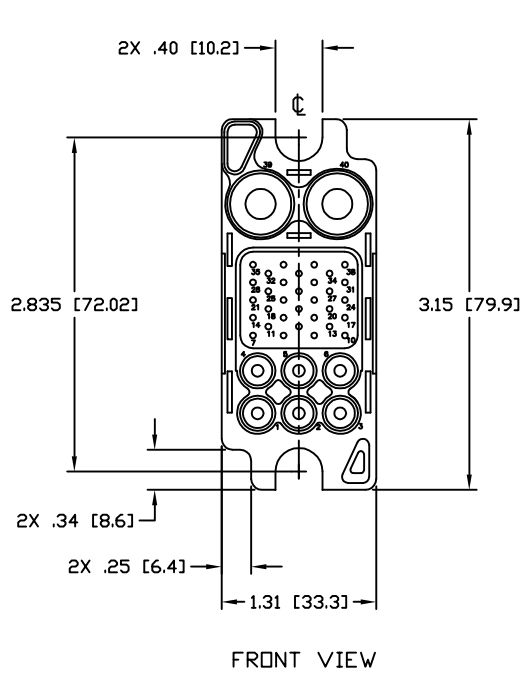

INCH OR INCH (MM)  THIRD ANGLE PROJECTION UNLESS OTHERWISE SPECIFIED DIMENSIONS ARE IN INCHES (METRIC) TOLERANCES ANGLES ± .5° DECIMALS .XXX ± .010 (.25) .XX ± .02 (.3)	DRAWN	DATE	Tyco Electronics Corporation Menlo Park, Ca 94025
	HA NGUYEN	03/25/06	
	CHECKED		TITLE
	APPROVED		CONNECTOR, PIN HOUSING 2X#4, 32X#20, 6X#12, FLOAT MOUNT 125A MIDDLE DRAWER
	APPROVED		SIZE DWG NUMBER
	STEVE FLICKINGER	03/25/06	B C = 1648151
	DCA APPROVED		REV.
	HA NGUYEN	03/25/06	A
	ACAD FILE NUMBER	C1648151A.DWG	DWG SCALE 1=1 SH 2 OF 3

This drawing involves proprietary design rights of Tyco Electronics Corporation, and all design, manufacture, reproduction, use and sale rights regarding the same are expressly reserved. It is submitted for a specific purpose and the recipient by accepting this drawing, assumes custody and control and agrees to take reasonable precautions: (a) that this drawing will not be copied and reproduced, in whole or in part, or its contents revealed in any manner, or to any person except to meet the purpose for which it was delivered and (b) that any special features peculiar to this design will not be incorporated in other projects without the expressed written permission of Tyco Electronics Corporation.

REVISIONS			
EC	REV	DESCRIPTION	DATE
		SEE SHEET 1	

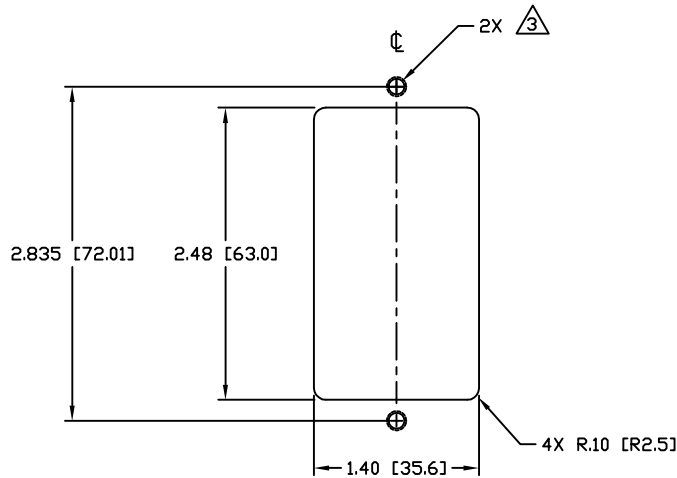

RECOMMENDED PANEL CUTOUT  
AS VIEWED FROM CONNECTOR MOUNTING SIDE  
(FRONT VIEW)

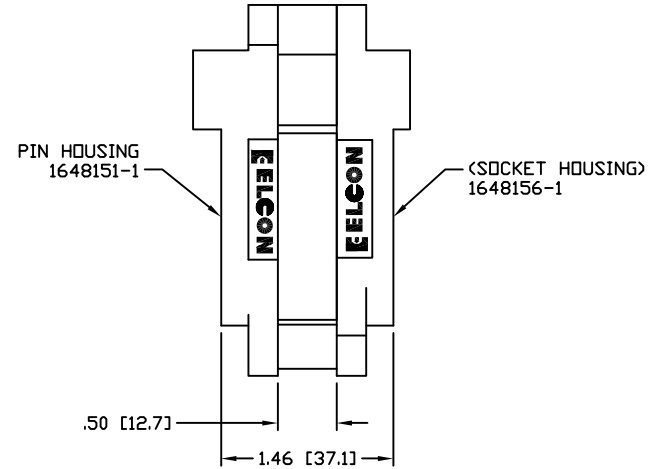

MATED CONDITION

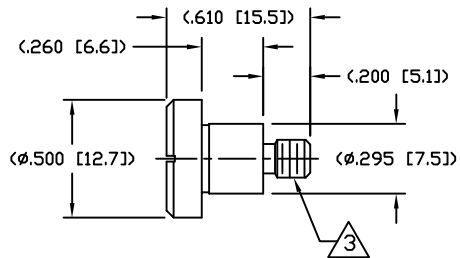

SHOULDER SCREW  
SCALE 2:1  
SHOWN FOR REFERENCE ONLY

INCH OR INCH (MM)  THIRD ANGLE PROJECTION UNLESS OTHERWISE SPECIFIED DIMENSIONS ARE IN INCHES (METRIC) TOLERANCES ANGLES $\pm .5^\circ$ DECIMALS .XXX $\pm .010 (.25)$ .XX $\pm .02 (.3)$	DRAWN HA NGUYEN	DATE 03/25/06	Tyco Electronics Corporation Menlo Park, Ca 94025	
	CHECKED		TITLE	
	APPROVED		USER INFORMATION RECOMMENDED PANEL CUTOUT AND MATED CONDITION	
	APPROVED STEVE FLICKINGER	03/25/06	SIZE B	DWG NUMBER C = 1648151
	DCA APPROVED HA NGUYEN	03/25/06		
	ACAD FILE NUMBER C1648151A.DWG			DWG SCALE 1=1 SH 3 OF 3