



TS1581

5A Dual Input Low Dropout Positive Voltage Regulator

TO-220-5L

TO-263-5L



Pin Assignment:

1. Sense
2. Adj / Gnd
3. Output
4. V control
5. V power

**Low Dropout Voltage 0.7V max.
Adjustable Output**

General Description

The TS1581 family is a positive adjustable and fixed voltage regulator developed to provide 5A with Higher efficiency than currently available devices. All internal circuit is designed to operate down to 700mV input to output differential and the dropout voltage is fully specified as a function of load current. Dropout voltage of the device is 100mV at light loads and rising to 700mV at maximum output current. A Second low current input is required to achieve this dropout. The TS1581 series are designed to prevent device failure under the worst operation condition with both Thermal Shutdown and Current Fold-back.

Features

- ✧ Very low dropout voltage: 700mV @5A
- ✧ Output current up to 1.5A
- ✧ Low current Consumption
- ✧ High Accuracy Output Voltage: +/- 1%
- ✧ Fast transient response
- ✧ Remote sense
- ✧ Internal current limit
- ✧ Thermal shutdown protection

Applications

- ✧ High efficiency linear voltage regulators
- ✧ Post regulators for switching supplies.
- ✧ Advance graphic card
- ✧ Adjustable power supply

Block Diagram

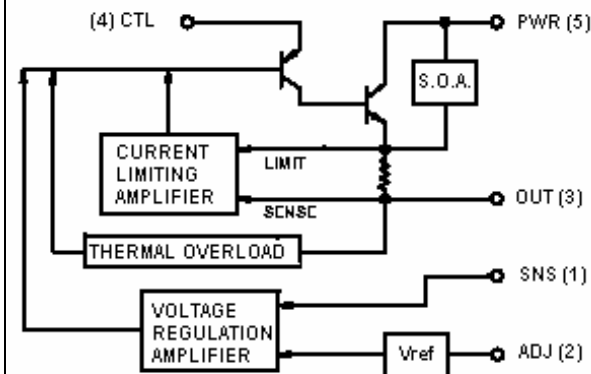

Ordering Information

Part No.	Operating Temp. (Ambient)	Package
TS1581CZ5-xx	0 ~ +85 °C	TO-220-5L
TS1581CZ5		
TS1581CM5-xx		TO-263-5L
TS1581CM5		

Note: Where xx denotes voltage option, available are 3.3V and 2.5V. Leave blank for adjustable version. Contact factory for additional voltage options.

Typical Application Circuit

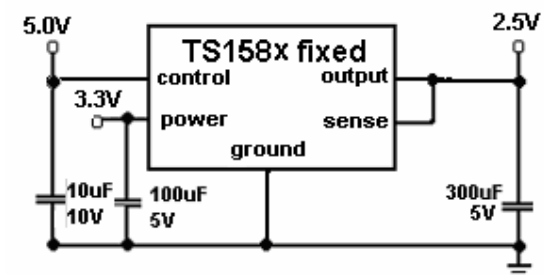
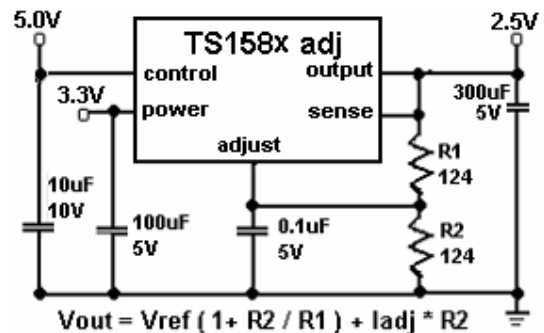



Absolute Maximum Rating			
Input Supply Voltage			
V power	V _{power}	7	V
V control	V _{control}	13	
Power Dissipation	P _D	Internally Limited	W
Operating Junction Temperature Range	T _J	0 ~ +125	°C
Storage Temperature Range	T _{STG}	-65 ~ +150	°C
Lead Soldering Temperature (260 °C)			
TO-220-5L / TO-263-5L Package		10	S

Electrical Characteristics

T_j=+25°C, C_{control}=C_{power}=C_{out}=10uF unless Specified

Parameter	Conditions	Min	Typ	Max	Unit
Reference Voltage (Adj. Voltage Versions)	V _{CONTROL} = 4.5V, V _{POWER} = 2.05V, I _O = 10mA	1.238	1.250	1.262	V
	V _{CONTROL} = 4.5V, V _{POWER} = 2.05V, I _O = 10mA to 5A	1.230		1.270	
Output Voltage (Fixed Voltage Versions)	V _{CONTROL} = 5V, V _{POWER} = V _{OUT} +0.8V, I _O =10mA	-1.0	V _{OUT}	+1.0	%
	V _{CONTROL} = 5V, V _{POWER} = V _{OUT} +0.8V, I _O = 10mA to 5A	-1.6		+1.6	
Line Regulation	V _{CONTROL} = (V _{out} +1.5V) to 12V, V _{POWER} = (V _{OUT} +0.8V) to 5.5V, I _O = 10mA		0.04	0.2	%
Load Regulation	V _{CONTROL} = (V _{out} +2.5V), V _{POWER} = (V _{OUT} +0.8V), I _O = 10mA to 5A		0.08	0.4	%
Mini. Load Current (Note 2)	V _{CONTROL} = 5V, V _{POWER} = 3.3V, V _{ADJ} = 0V		5	10	mA
Control Pin Current (Note 3)	V _{CONTROL} = (V _{OUT} +2.5V), V _{POWER} = (V _{OUT} +0.8V), I _O = 10mA to 5A		80	135	mA
Adjust Pin Current	V _{CONTROL} = 2.75V, V _{POWER} = 2.05, V _{ADJ} = 0V, I _O = 10mA		50	120	uA
Current Limit	V _{POWER} - V _{OUT} = 3V	5.5	6.8		A
Ripple Rejection	V _{CONTROL} = V _{POWER} = 5V, V _{RIPPLE} = 1V, I _O = 2.5A, f = 120kHz	60	80		dB
Thermal Regulation	30mS pulse		0.003		%/W
Dropout Voltage (Note 4)	V _{CONTROL} = (V _{out} +2.5V), I _O = 5A		0.55	0.70	V

Note1: V_{OUT} = V_{SENSE}, V_{ADJ} = 0V unless otherwise specified.

Note2: For the adjustable device the minimum load current is the minimum current required to maintain regulation, normally the current in the resistor divider used to set the output voltage is selected to meet the minimum load current requirement.

Note3: The control pin current is the drive current required for the output transistor, this current will track output current with a ratio of about 1:100

Note4: If the same voltage is input to both V_{POWER} and V_{CONTROL}, then the dropout voltage will become 1.3V maximum, and minimum input/output voltage required to maintain 1% regulation.



Thermal Performance			
Condition	Package type	Typ	Unit
Thermal Resistance	TO-220-5L	50	°C/W
Junction to Ambient	TO-263-5L	60	
Pin Description			
Pin No.	Pin Name	Pin Description	
1	Sense	This pin is the positive side of the reference voltage for this device. With this pin it is possible to Kelvin Sense the output voltage at the load.	
2	Adjust / Ground	This pin is the negative side of the reference voltage for this device. Transient response can be improved by adding a small bypass capacitor from the adjust pin to ground.	
3	Output	This pin is power output of the device.	
4	Control	This pin is the supply pin for the control circuitry for the device. The current flow into this pin will be about 1% of the output current. For the device to regulate, the voltage at this pin must be 1.3V greater than the output voltage.	
5	Power	This pin is the collector of the power transistor. The output load current is supplied through this pin. The voltage at this pin must be 0.7V greater than the output voltage for the device to regulate.	

Application Information

The TS1581 is a low dropout regulator designed to make use of multiple power supplies, present in most systems, to reduce the dropout voltage. One of the advantages of the two supply approach is maximizing the efficiency. The second supply is at least 1V greater than output voltage and is providing the power for the control circuitry and supplies the drive current to the NPN output transistor. This allows the NPN output transistor to be driven into saturation. For the control voltage the current requirement is small equal to about 1% of the output current or approximately 50mA for a 5A load. This drive current becomes part of the output current. The maximum voltage on the Control Pin is 15V. The maximum voltage at the Power in is 7V. By tying the control and power inputs together the TS1581 can also be operated as a single supply device. In single supply operation the dropout will be determined by the minimum control voltage.

Both the fixed and adjustable versions have remote sense pins, permitting very accurate regulation of output voltage. As a result, over and output current range of 100mA to 5A, the typical load regulation is less than 1mV. For the fixed voltages the adjust pin is brought out allowing the user to improve transient response by bypassing the internal resistor divider. Optimum transient response is provided using a capacitor in the range of 0.1uF to 1uF for bypassing the adjust pin.

The new generation of microprocessors cycle load current from several hundred million amperes to several amperes in tens of nanoseconds. Output voltage tolerances are tighter and include transient response as part of the specification. Designed to meet the fast current load step requirements of these microprocessors, the TS1581 also saves total cost by needing less output capacitance to maintain regulation. Typical applications for the TS1581 include 3.3V to 2.5V conversion with a 5V control supply, 5V to 4.2V conversion with a 12V control supply or 5V to 3.6V conversion with a 12V control supply. It is easy to obtain dropout voltages less than 0.5V at 2.5A along with excellent static and dynamic specifications. It is fully protected against over current and over temperature conditions.

Grounding and Output Sensing

The TS1581 allows true Kelvin sensing for both the high & low side of the load. A result the voltage regulation at the load can be easily optimized. Voltage drops due to parasitic resistances between the regulator and the load can be placed inside the regulation loop. The advantages of remote sensing are illustrated in Figure 1 through 3.

Figure 1 show the device connected as a conventional 3 terminal regulator with the Sense lead connected directly to the output of the device. R_p is the parasitic resistance of the connections between the device and the load. Trace A of Figure 3 illustrates the effect of R_p

Figure 1. Conventional Load Sensing

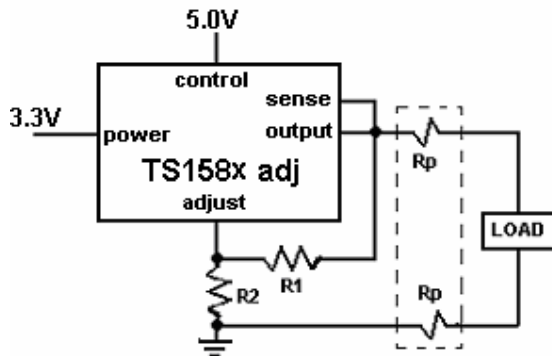
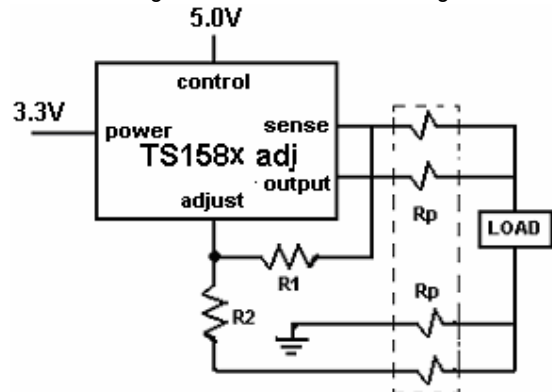

Figure 2 show the device connected to take advantage of the remote sense feature. The Sense Pin and the top of the resistor divider are connected to the top of the load; the bottom of the resistor divider is connected to the bottom of the load.

Figure 2. Remote Load Sensing



The effect on output regulation can be seen in trace B of Figure 3. It is important to note that the voltage drops due to R_p are not eliminated; they will add to the dropout voltage of the regulator regardless. The TS1581 can control the voltage at the load as long as the input-output voltage is greater than the total of the dropout voltage of the device plus the voltage drop across R_p

Figure 3. Remote Sensing Improves Load Regulation

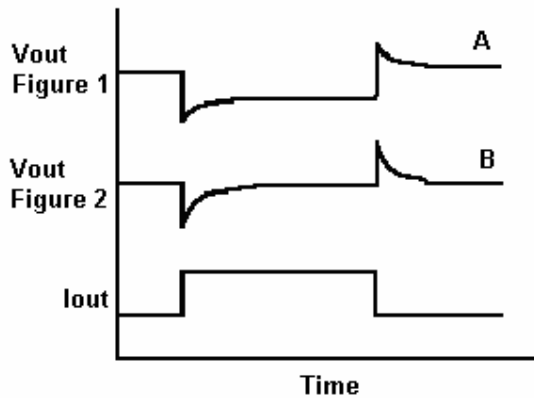

Stability

The circuit design used in the TS1581 Series requires the use of an output capacitor as part of the device frequency compensation. The addition of 150uF aluminum electrolytic or a 22uF solid tantalum on the output will ensure stability for all operating conditions. In order to meet the transient performance of the processor larger value capacitors are needed. To limit the high frequency noise generated by the processor high quality bypass capacitors must be used. In order to limit parasitic inductance (ESL) and resistance (ESR) in capacitors to acceptable limits, multiple small ceramic capacitors in addition to high quality solid tantalum capacitors are required.

When the adjustment terminal is bypass to improve the ripple rejection, the requirement for an output capacitor increases. The Adjust pin is brought out on the fixed voltage device specifically to allow this capability. To further improve stability and transient response of these devices larger values of output capacitor can be used. The modern processors generate large high frequency current transients. The load current step contains higher order frequency components than the output coupling network must handle until the regulator throttles to the load current level.

Because they contain parasitic resistance and inductance, capacitors are not ideal elements. These parasitic elements dominate the change in output voltage as the beginning of a transient load step change. The ESR of the output capacitors produces an instantaneous step in output voltage $\Delta V = \Delta I (ESR)$. The ESL of the output capacitors produces a drop proportional to the rate of change of the output current $V = L (\Delta I / \Delta t)$. The output capacitance produces a change in output voltage proportional to the time until the regulator can respond $\Delta V = \Delta t (\Delta I / C)$.

Figure 4. illustrates these transient effects.

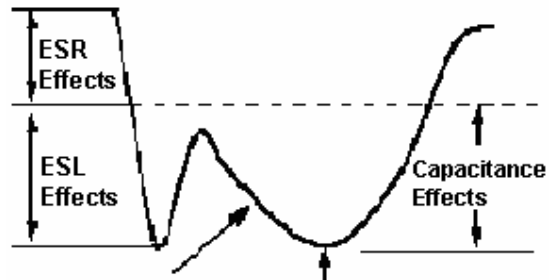

Slope, $V/t = \Delta I / C$ Point at which regulator Output voltage

The TS1581 (adjustable version) develops a 1.25V reference voltage between the Sense Pin and the Adjust Pin (Figure 5). Placing a resistor between these two terminals causes a constant current to flow through R_1 and down through R_2 to set the output voltage. In general R_1 is chosen so that this current is the specified minimum load current of 10mA. The current out of the Adjust pin is small, typically 50uA and it adds to the current from R_1 . For best regulation the top of the resistor divider should be connected directly to the Sense pin.

Figure 5. Setting Output Voltage

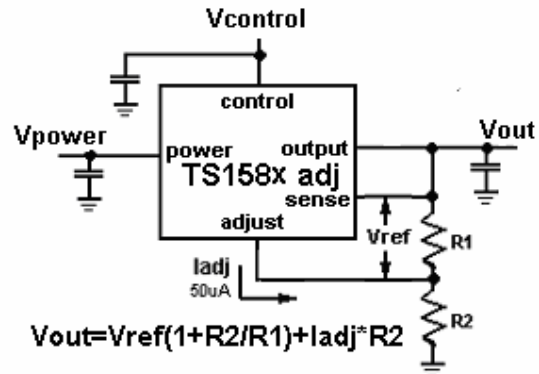

Protection Diodes

In normal operation TS1581 family does not need any protection diodes between the Adjust pin and the output and from the output to the input to prevent die overstress. Internal resistors are limiting the internal current paths on the Adjust pin. Therefore even with bypass capacitors on the Adjust pin no protection diode is needed to ensure device safety under short-circuit conditions. The Adjust pin can be driven on a transient basis +/-7V with respect to the output without any device degradation.

A protection diode between the Output pin and Vpower pin is not usually needed. Microsecond surge currents of 50A to 100A can be handled by the internal diode between the Output pin and Vpower pin of the device. In normal operations it is difficult to get those values of surge currents even with the use of large output capacitances. Only with high value output capacitors, such as 1000uF to 5000uF and the Vpower pin is instantaneously shorted to ground, damage can occur. A diode from output to input is recommended.

Figure 6. Optional Clamp Diodes Protect Against Input

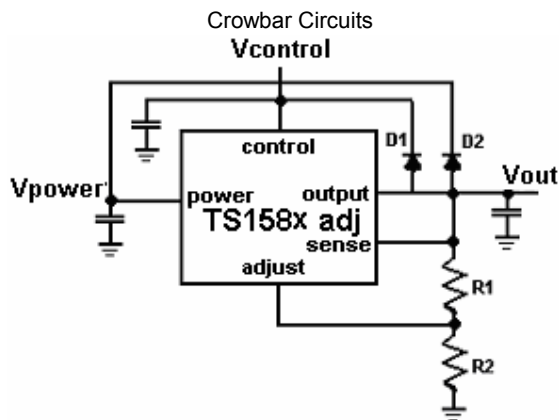

If TS1581 is connected as a single supply device with the control and power input pins shorted together the internal diode between the output and the power input pin will protect the control input pin.

Thermal Considerations

The TS1581 family have internal power and thermal limiting circuit designed to protect the device under overload conditions. However maximum junction temperature ratings should not be exceeded under continuous normal load conditions. Careful consideration must be given to all sources of thermal resistance from junction to ambient,

including junction-to-case, case-to-heat sink interface and heat sink resistance itself. Junction temperature of the Control section can run up to 125°C. Junction temperature of the Power section can run up to 150°C. Due to the thermal gradients between the power transistor and the control circuitry there is a significant difference in thermal resistance between the Control and Power sections.

Virtually all the power dissipated by the device is dissipated in the power transistor. The temperature rise in the power transistor will be greater than the temperature rise in the Control section making the thermal resistance lower in the Control section. At power levels below 12W the temperature gradient will be less than 25°C and the maximum ambient temperature will be determined by the junction temperature of the Control section. This is due to the lower maximum junction temperature in the Control section. At power levels above 12W the temperature gradient will be greater than 25°C and the maximum ambient temperature will be determined by the Power section. In both cases the junction temperature is determined by the total power dissipated in the device. For most low dropout applications the power dissipation will be less than 12W.

The power in the device is made up of two components: the power in the output transistor and the power in the control circuit.

The power in the control circuit is negligible.

The power in the control circuit is equal to:

$$P_{\text{control}} = (V_{\text{control}} - V_{\text{out}}) (I_{\text{control}})$$

Where I_{control} is equal $I_{\text{out}} / 100$ (typ)

The power in the out transistor is equal to:

$$P_{\text{output}} = (V_{\text{power}} - V_{\text{out}}) (I_{\text{out}})$$

The total power is equal to:

$$P_{\text{total}} = P_{\text{control}} + P_{\text{output}}$$

Junction-to-case thermal resistances is specified from the IC junction to the bottom of the case directly below the die. This is the lowest resistance path for the heat flow. In order to ensure the best possible thermal flow this area of the package to the heat sink proper mounting is required. Thermal compound at the case-to-heat sink interface is recommended. A thermally conductive spacer can be used, if the case of the device must be electrically isolated, but its added contribution to thermal resistance has to be considered.

TO-220 Mechanical Drawing

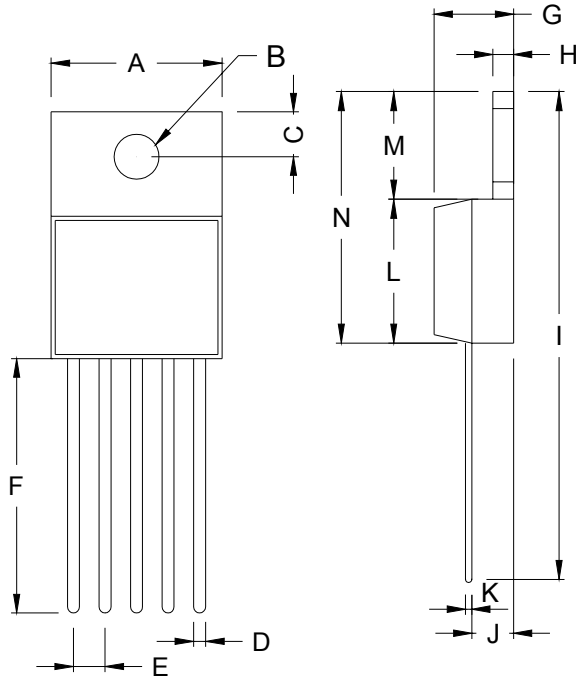

DIM	TO-220 DIMENSION			
	MILLIMETERS		INCHES	
	MIN	MAX	MIN	MAX
A	10.00	10.50	0.394	0.413
B	3.240	4.440	0.128	0.175
C	2.440	2.940	0.096	0.116
D	0.260	1.020	0.010	0.040
E	1.570	1.830	0.062	0.072
F	13.31	14.13	0.524	0.556
G	4.475	5.225	0.176	0.206
H	1.170	1.370	0.046	0.054
I	27.60	29.44	1.087	1.159
J	2.175	2.925	0.086	0.115
K	0.297	0.477	0.012	0.019
L	8.280	8.800	0.326	0.346
M	6.010	6.510	0.237	0.256
N	14.29	15.31	0.563	0.603

TO-263 Mechanical Drawing

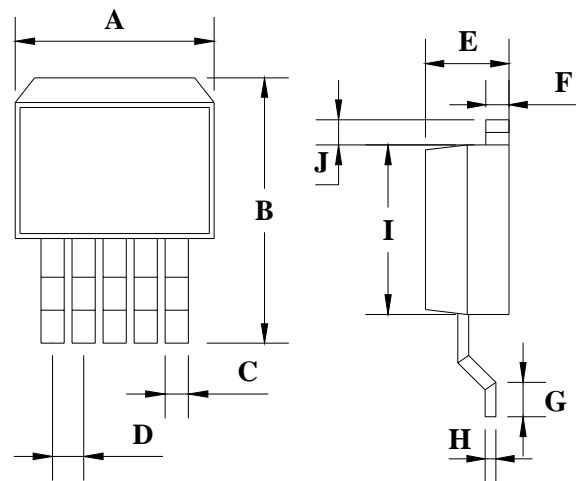

DIM	TO-263 DIMENSION			
	MILLIMETERS		INCHES	
	MIN	MAX	MIN	MAX
A	10.220	10.260	0.402	0.404
B	14.600	15.870	0.575	0.625
C	0.750	0.770	0.030	0.030
D	1.573	1.827	0.062	0.072
E	4.560	4.570	0.179	0.180
F	1.240	1.270	0.049	0.050
G	2.280	2.790	0.090	0.110
H	0.280	0.320	0.011	0.013
I	8.240	8.280	0.324	0.326
J	1.540	1.800	0.060	0.071