

RoHS Compliant Product

SOT-223

Description

The PZTA42 is designed for application as a video output to drive color CRT, or as dialer circuit in electronics telephone.

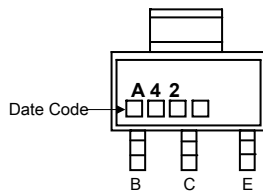
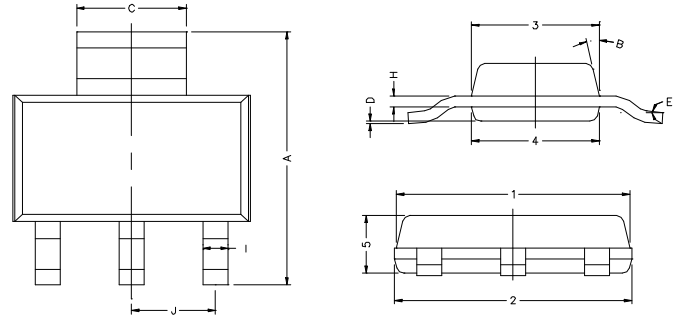

| REF. | Millimeter | | REF. | Millimeter | |
|------|------------|------|------|------------|------|
| | Min. | Max. | | Min. | Max. |
| A | 6.70 | 7.30 | B | 13 TYP. | |
| C | 2.90 | 3.10 | J | 2.30 REF. | |
| D | 0.02 | 0.10 | 1 | 6.30 | 6.70 |
| E | 0° | 10° | 2 | 6.30 | 6.70 |
| I | 0.60 | 0.80 | 3 | 3.30 | 3.70 |
| H | 0.25 | 0.35 | 4 | 3.30 | 3.70 |
| | | | 5 | 1.40 | 1.80 |

ABSOLUTE MAXIMUM RATINGS Ta=25°C

| Symbol | Parameter | Value | Units |
|-----------------------------------|----------------------------------|----------|-------|
| V _{CB0} | Collector-Base Voltage | 300 | V |
| V _{CEO} | Collector-Emitter Voltage | 300 | V |
| V _{EBO} | Emitter-Base Voltage | 6 | V |
| I _C | Collector Current | 500 | mA |
| P _D | Total Power Dissipation | 2 | W |
| T _J , T _{stg} | Junction and Storage Temperature | -55~+150 | °C |

ELECTRICAL CHARACTERISTICS Tamb=25°C unless otherwise specified

| Parameter | Symbol | Min | Typ. | Max | Unit | Test Conditions |
|-------------------------------------|----------------------|-----|------|-----|------|---|
| Collector-Base Breakdown Voltage | BV _{CB0} | 300 | - | - | V | I _C =100μA |
| Collector-Emitter Breakdown Voltage | BV _{CEO} | 300 | - | - | V | I _C =1mA |
| Emitter-Base Breakdown Voltage | BV _{EBO} | 6 | - | - | V | I _E =10μA |
| Collector-Base Cutoff Current | I _{CB0} | - | - | 100 | nA | V _{CB} =300V |
| Emitter-Base Cutoff Current | I _{EBO} | - | - | 100 | nA | V _{EB} =6V |
| Collector Saturation Voltage | V _{CE(sat)} | - | - | 500 | mV | I _C =20 mA, I _B =2mA |
| Base Saturation Voltage | V _{BE(sat)} | - | - | 900 | mV | I _C =20 mA, I _B =2mA |
| DC Current Gain | h _{FE1} | 25 | - | - | | V _{CE} = 10V, I _C = 1mA |
| | h _{FE2} | 40 | - | - | | V _{CE} = 10V, I _C =10mA |
| | h _{FE3} | 40 | - | - | | V _{CE} = 10V, I _C =30 mA |
| Gain-Bandwidth Product | f _T | 50 | - | - | MHz | V _{CE} = 20mV, I _C = 10mA, f=100MHz |
| Output Capacitance | C _{ob} | - | - | 3 | pF | V _{CB} = 20V, f=1MHz |