

LOW POWER DUAL COMPARATORS

DESCRIPTION

The μ PC393 is a dual comparator which is designed to operate from a single power supply over a wide range of voltage. Operation from split power supplies is also possible and the power supply current drain is very low. Further advantage, the input common-mode voltage includes ground, even though operated from a single power supply voltage.

FEATURES

- Common-mode input voltage range includes V^-
- Wide supply voltage range
2 V to 32 V (Single)
 ± 1 V to ± 16 V (Split)
- Low supply current
- Open collector output

EQUIVALENT CIRCUIT (1/2 Circuit)

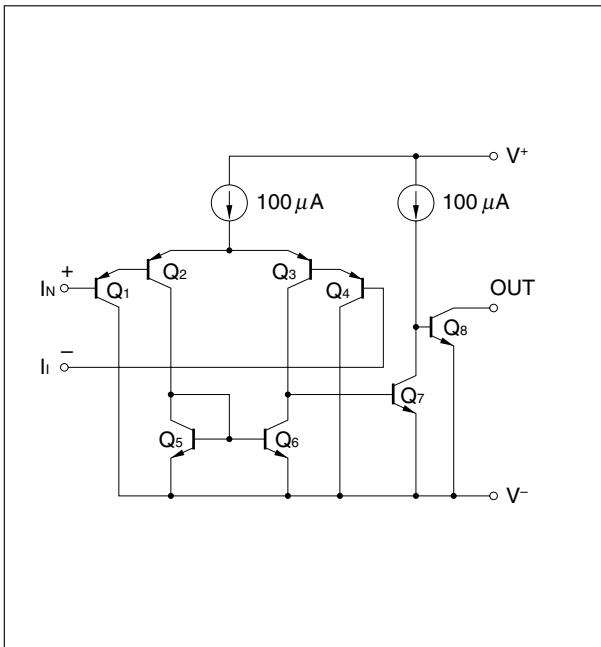

PIN CONFIGURATION (Top View)

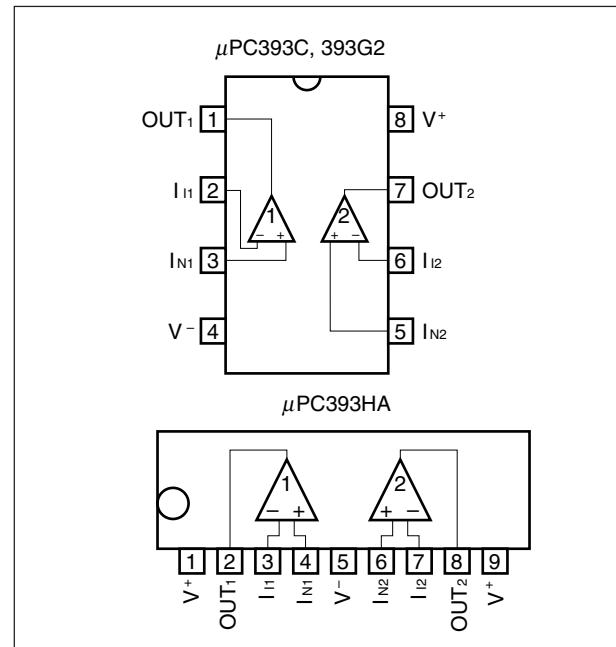

ORDERING INFORMATION

Part Number	Package
μ PC393C	8-pin plastic DIP (7.62 mm (300))
μ PC393G2	8-pin plastic SOP (5.72 mm (225))
μ PC393G2(5)	8-pin plastic SOP (5.72 mm (225))
μ PC393HA	9-pin plastic slim SIP

The information in this document is subject to change without notice. Before using this document, please confirm that this is the latest version.
Not all products and/or types are available in every country. Please check with an NEC Electronics sales representative for availability and additional information.

ABSOLUTE MAXIMUM RATINGS (T_A = 25 °C)

Parameter		Symbol	Ratings	Unit
Voltage between V ⁺ and V ⁻	Note 1	V ⁺ -V ⁻	-0.3 to +36	V
Differential Input Voltage		V _{ID}	±36	V
Input Voltage	Note 2	V _I	V ⁻ -0.3 to V ⁻ +36	V
Output Voltage	Note 3	V _O	V ⁻ -0.3 to V ⁻ +36	V
Power Dissipation	C Package Note 4	P _T	350	mW
	G2 Package Note 5		440	mW
	HA Package Note 4		350	mW
Output Short Circuit Duration	Note 6		Indefinite	sec
Operating Ambient Temperature		T _A	-20 to +80	°C
Storage Temperature		T _{stg}	-55 to + 125	°C

- Notes**
- Reverse connection of supply voltage can cause destruction.
 - The input voltage should be allowed to input without damage or destruction independent of the magnitude of V⁺. Either input signal should not be allowed to go negative by more than 0.3 V. The normal operation will establish when any input is within the Common Mode Input Voltage Range of electrical characteristics.
 - This specification is the voltage which should be allowed to supply to the output terminal from external without damage or destruction independent of the magnitude of V⁺. Even during the transition period of supply voltage, power on/off etc., this specification should be kept.
 - Thermal derating factor is -5.0 mW/°C when operating ambient temperature is higher than 55 °C.
 - Thermal derating factor is -4.4 mW/°C when operating ambient temperature is higher than 25 °C.
 - Short circuits from the output to V⁺ can cause destruction. Pay careful attention to the total power dissipation not to exceed the absolute maximum ratings, Note 4 and Note 5.

RECOMMENDED OPERATING CONDITIONS

Parameter	Symbol	MIN.	TYP.	MAX.	Unit
Supply Voltage (Split)	V [±]	±1		±16	V
Supply Voltage (V ⁻ = GND)	V ⁺	+2		+32	V

μPC393C, μPC393G2, μPC393HA

ELECTRICAL CHARACTERISTICS (T_A = 25 °C, V⁺ = 5 V, V⁻ = GND)

Parameter	Symbol	Conditions	MIN.	TYP.	MAX.	Unit
Input Offset Voltage	V _{IO}	V _O = 1.4 V, V _{REF} = 1.4 V, R _S = 0 Ω		±2	±5	mV
Input Offset Current	I _{IO}	V _O ≐ 1.4 V		±5	±50	nA
★ Input Bias Current ^{Note 7}	I _B	V _O ≐ 1.4 V		25	250	nA
Voltage Gain	A _v	R _L = 15 kΩ		200		V/mV
★ Supply Current ^{Note 8}	I _{CC}	R _L = ∞, I _O = 0 A		0.6	1	mA
Common Mode Input Voltage Range	V _{ICM}		0		V ⁺ -1.5	V
Output Saturation Voltage	V _{OL}	V _{IN(-)} = 1 V, V _{IN(+)} = 0 V, I _{O SINK} = 4 mA		0.2	0.4	V
Output Sink Current	I _{O SINK}	V _{IN(-)} = 1 V, V _{IN(+)} = 0 V, V _O ≤ 1.5 V	6	16		mA
Output Leakage Current	I _{O LEAK}	V _{IN(+)} = 1 V, V _{IN(-)} = 0 V, V _O = 5 V		0.1		nA
Response Time		R _L = 5.1 kΩ, V _{RL} = 5 V		1.3		μs

★ μPC393G2(5)

ELECTRICAL CHARACTERISTICS (T_A = 25 °C, V⁺ = 5 V, V⁻ = GND)

Parameter	Symbol	Conditions	MIN.	TYP.	MAX.	Unit
Input Offset Voltage	V _{IO}	V _O = 1.4 V, V _{REF} = 1.4 V, R _S = 0 Ω		±2	±2.5	mV
Input Offset Current	I _{IO}	V _O ≐ 1.4 V		±5	±50	nA
Input Bias Current ^{Note 7}	I _B	V _O ≐ 1.4 V		25	60	nA
Voltage Gain	A _v	R _L = 15 kΩ		200		V/mV
Supply Current ^{Note 8}	I _{CC}	R _L = ∞, I _O = 0 A		0.6	1	mA
Common Mode Input Voltage Range	V _{ICM}		0		V ⁺ -1.4	V
Output Saturation Voltage	V _{OL}	V _{IN(-)} = 1 V, V _{IN(+)} = 0 V, I _{O SINK} = 4 mA			0.2	V
Output Sink Current	I _{O SINK}	V _{IN(-)} = 1 V, V _{IN(+)} = 0 V, V _O ≤ 1.5 V	10	16		mA
Output Leakage Current	I _{O LEAK}	V _{IN(+)} = 1 V, V _{IN(-)} = 0 V, V _O = 5 V		0.1	100	nA
Response Time		R _L = 5.1 kΩ, V _{RL} = 5 V		1.3		μs

★ **Notes 7.** Input bias currents flow out from IC. Because each currents are base current of PNP-transistor on input stage.

8. This current flows irrespective of the existence of use.

APPLICATION CIRCUIT EXAMPLE

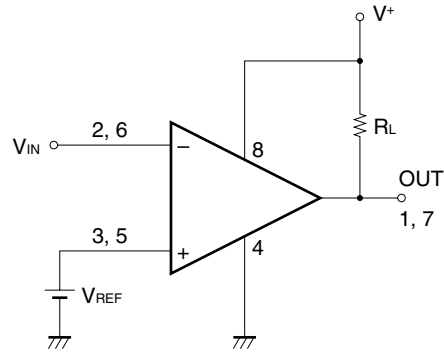

V_{REF} : V^- to $V^+ - 1.5$ (V)

COMPARATOR with HYSTERESIS CIRCUIT

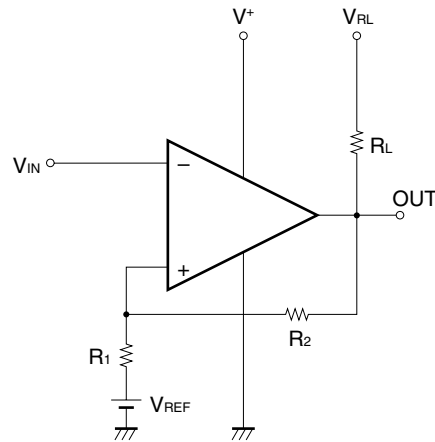

- Threshold voltage

$$V_{TH(High)} \doteq V_{REF} + \frac{R_1}{R_L + R_2 + R_1} (V_{RL} - V_{REF})$$

$$V_{TH(Low)} \doteq V_{REF} - \frac{R_1}{R_1 + R_2} (V_{REF} - V_{OL})$$

$(V_{RL} > V_{REF} > V_{OL})$

TYPICAL PERFORMANCE CHARACTERISTICS ($T_A = 25\text{ }^\circ\text{C}$, TYP.)

POWER DISSIPATION

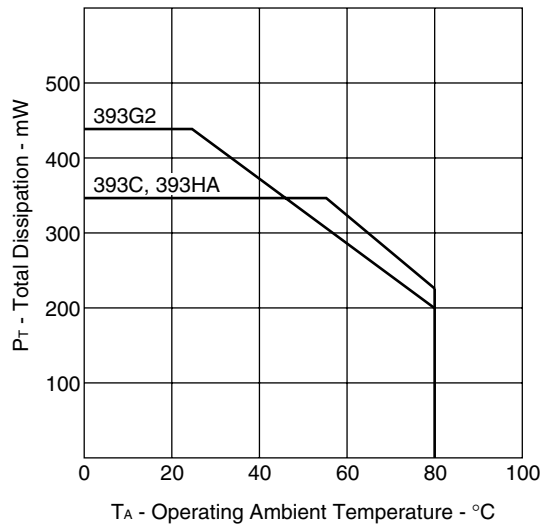

SUPPLY CURRENT

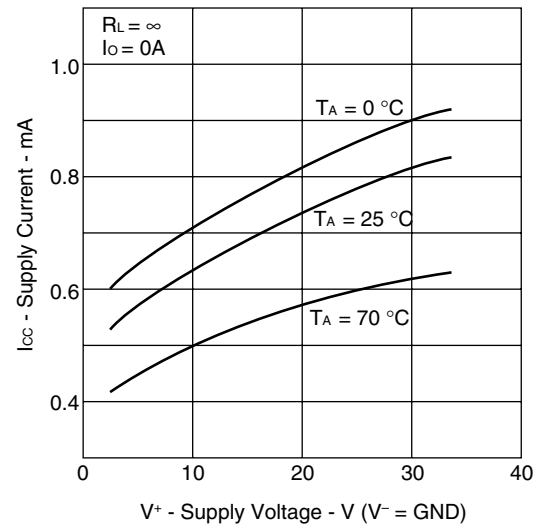

★ INPUT OFFSET VOLTAGE

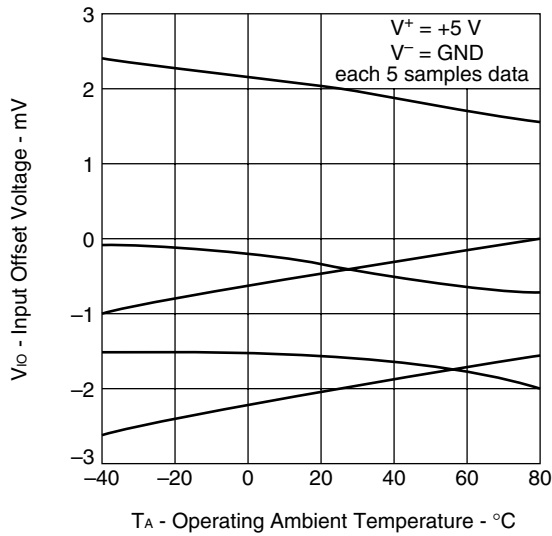

INPUT BIAS CURRENT

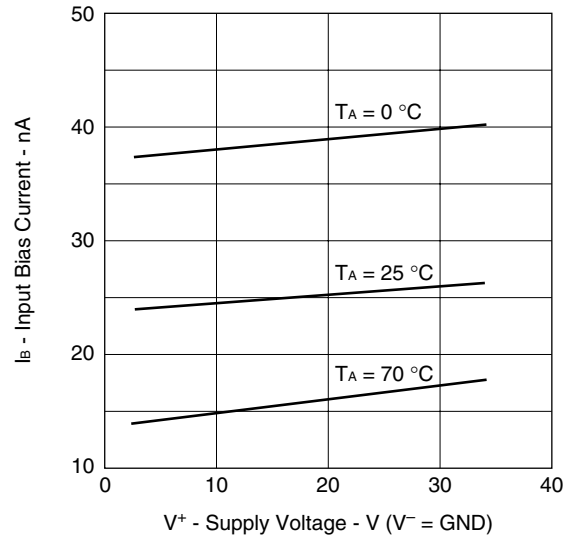

OUTPUT SATURATION VOLTAGE

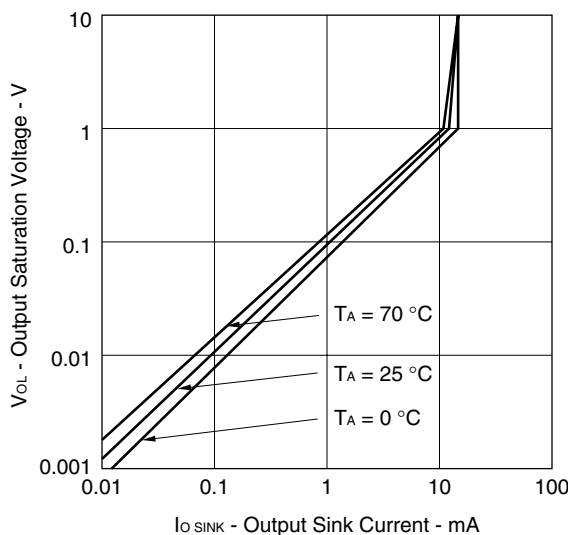

★ RESPONSE TIME FOR VARIOUS INPUT OVERDRIVES I

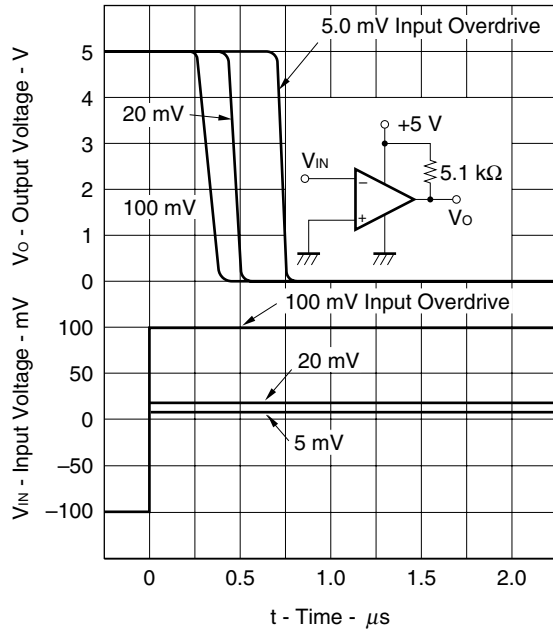

★ RESPONSE TIME FOR VARIOUS INPUT OVERDRIVES II

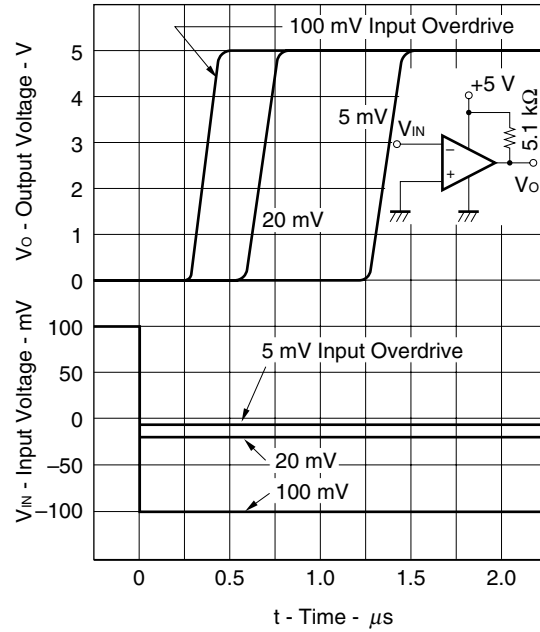

★ PACKAGE DRAWINGS (Unit: mm)

8-PIN PLASTIC DIP (7.62mm(300))

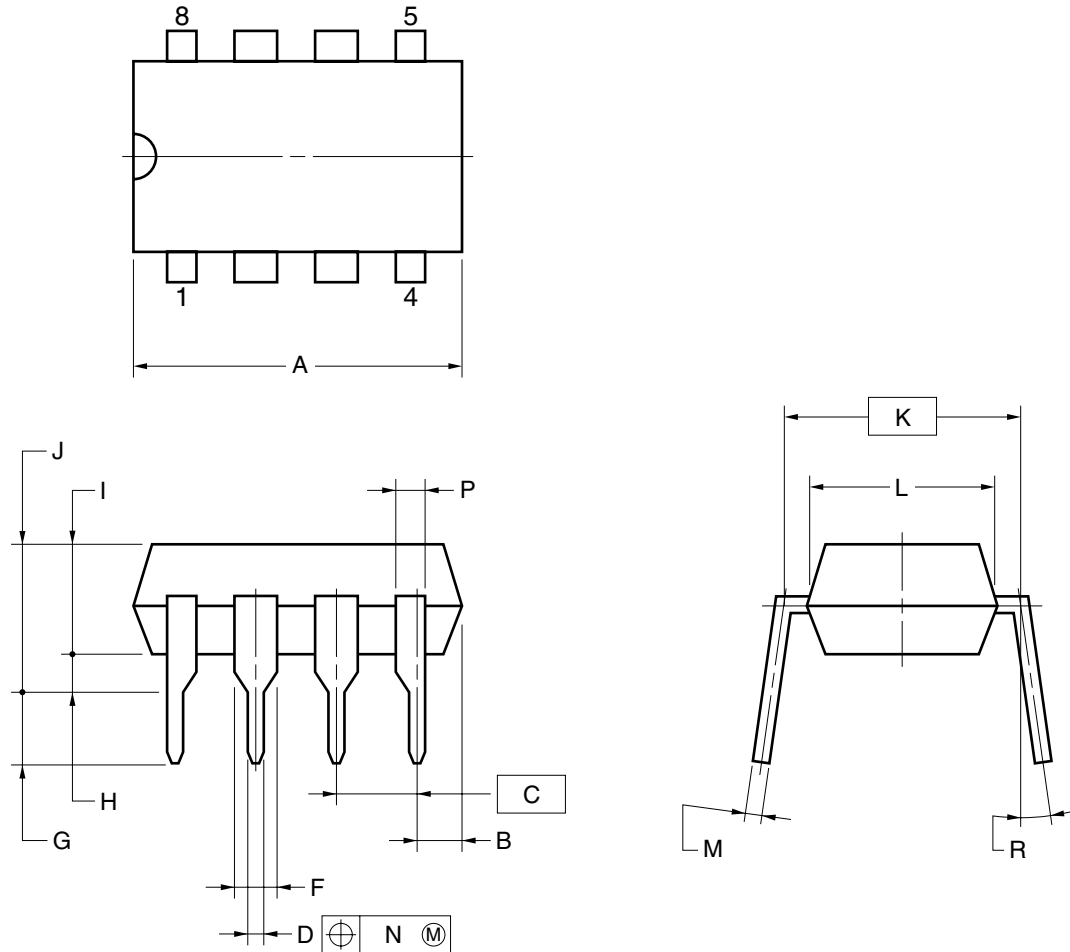

NOTES

1. Each lead centerline is located within 0.25 mm of its true position (T.P.) at maximum material condition.
2. Item "K" to center of leads when formed parallel.

ITEM	MILLIMETERS
A	10.16 MAX.
B	1.27 MAX.
C	2.54 (T.P.)
D	0.50±0.10
F	1.4 MIN.
G	3.2±0.3
H	0.51 MIN.
I	4.31 MAX.
J	5.08 MAX.
K	7.62 (T.P.)
L	6.4
M	0.25 ^{+0.10} _{-0.05}
N	0.25
P	0.9 MIN.
R	0-15°

P8C-100-300B,C-2

8-PIN PLASTIC SOP (5.72 mm (225))

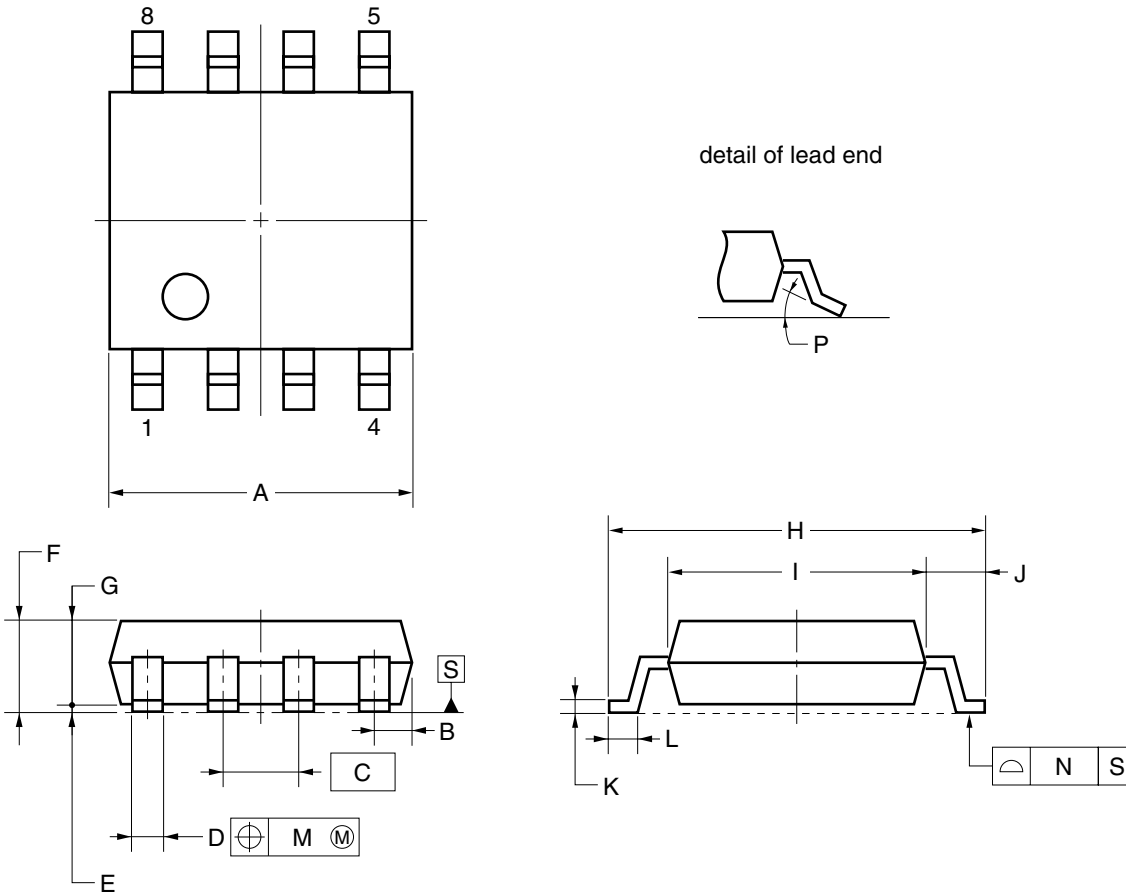

NOTE

Each lead centerline is located within 0.12 mm of its true position (T.P.) at maximum material condition.

ITEM	MILLIMETERS
A	5.2 $\begin{smallmatrix} +0.17 \\ -0.20 \end{smallmatrix}$
B	0.78 MAX.
C	1.27 (T.P.)
D	0.42 $\begin{smallmatrix} +0.08 \\ -0.07 \end{smallmatrix}$
E	0.1±0.1
F	1.59±0.21
G	1.49
H	6.5±0.3
I	4.4±0.15
J	1.1±0.2
K	0.17 $\begin{smallmatrix} +0.08 \\ -0.07 \end{smallmatrix}$
L	0.6±0.2
M	0.12
N	0.10
P	$\begin{smallmatrix} 3^{\circ}+7^{\circ} \\ -3^{\circ} \end{smallmatrix}$

S8GM-50-225B-6

9-PIN PLASTIC SLIM SIP

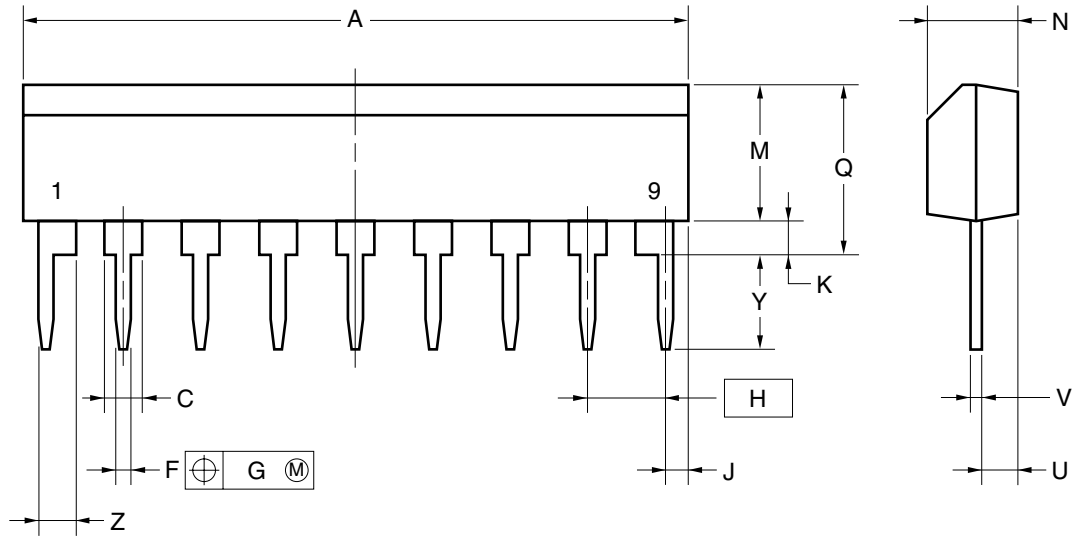

NOTE

Each lead centerline is located within 0.25 mm of its true position (T.P.) at maximum material condition.

ITEM	MILLIMETERS
A	22.86 MAX.
C	1.1 MIN.
F	0.5±0.1
G	0.25
H	2.54
J	1.27 MAX.
K	0.51 MIN.
M	5.08 MAX.
N	2.8±0.2
Q	5.75 MAX.
U	1.5 MAX.
V	0.25 ^{+0.10} _{-0.05}
Y	3.2±0.5
Z	1.1 MIN.

P9HA-254B-2

★ RECOMMENDED SOLDERING CONDITIONS

The μPC393 should be soldered and mounted under the following recommended conditions.

For soldering methods and conditions other than those recommended below, contact an NEC Electronics sales representative.

For technical information, see the following website.

Semiconductor Device Mount Manual (<http://www.necel.com/pkg/en/mount/index.html>)

Type of surface mount device

μPC393G2, μPC393G2(5): 8-pin plastic SOP (5.72 mm (225))

Process	Conditions	Symbol
Infrared Ray Reflow	Peak temperature: 230 °C or below (Package surface temperature), Reflow time: 30 seconds or less (at 210 °C or higher), Maximum number of reflow processes: 1 time.	IR30-00-1
Vapor Phase Soldering	Peak temperature: 215 °C or below (Package surface temperature), Reflow time: 40 seconds or less (at 200 °C or higher), Maximum number of reflow processes: 1 time.	VP15-00-1
Wave Soldering	Solder temperature: 260 °C or below, Flow time: 10 seconds or less, Maximum number of flow processes: 1 time, Pre-heating temperature: 120 °C or below (Package surface temperature).	WS60-00-1
Partial Heating Method	Pin temperature: 300 °C or below, Heat time: 3 seconds or less (Per each side of the device).	—

Caution Apply only one kind of soldering condition to a device, except for “partial heating method”, or the device will be damaged by heat stress.

Type of through-hole device

μPC393C : 8-pin plastic DIP (7.62 mm (300))

μPD393HA: 9-pin plastic slim SIP

Process	Conditions
Wave Soldering (only to leads)	Solder temperature: 260 °C or below, Flow time: 10 seconds or less.
Partial Heating Method	Pin temperature: 300 °C or below, Heat time: 3 seconds or less (per each lead.)

Caution For through-hole device, the wave soldering process must be applied only to leads, and make sure that the package body does not get jet soldered.

REFERENCE DOCUMENTS

★	QUALITY GRADES ON NEC SEMICONDUCTOR DEVICES	C11531E
	SEMICONDUCTOR DEVICE MOUNT MANUAL	http://www.necel.com/pkg/en/mount/index.html
	NEC SEMICONDUCTOR DEVICE RELIABILITY/	IEI-1212
	QUALITY CONTROL SYSTEM - STANDARD LINEAR IC	

- **The information in this document is current as of March, 2004. The information is subject to change without notice. For actual design-in, refer to the latest publications of NEC Electronics data sheets or data books, etc., for the most up-to-date specifications of NEC Electronics products. Not all products and/or types are available in every country. Please check with an NEC Electronics sales representative for availability and additional information.**
- No part of this document may be copied or reproduced in any form or by any means without the prior written consent of NEC Electronics. NEC Electronics assumes no responsibility for any errors that may appear in this document.
- NEC Electronics does not assume any liability for infringement of patents, copyrights or other intellectual property rights of third parties by or arising from the use of NEC Electronics products listed in this document or any other liability arising from the use of such products. No license, express, implied or otherwise, is granted under any patents, copyrights or other intellectual property rights of NEC Electronics or others.
- Descriptions of circuits, software and other related information in this document are provided for illustrative purposes in semiconductor product operation and application examples. The incorporation of these circuits, software and information in the design of a customer's equipment shall be done under the full responsibility of the customer. NEC Electronics assumes no responsibility for any losses incurred by customers or third parties arising from the use of these circuits, software and information.
- While NEC Electronics endeavors to enhance the quality, reliability and safety of NEC Electronics products, customers agree and acknowledge that the possibility of defects thereof cannot be eliminated entirely. To minimize risks of damage to property or injury (including death) to persons arising from defects in NEC Electronics products, customers must incorporate sufficient safety measures in their design, such as redundancy, fire-containment and anti-failure features.
- NEC Electronics products are classified into the following three quality grades: "Standard", "Special" and "Specific".

The "Specific" quality grade applies only to NEC Electronics products developed based on a customer-designated "quality assurance program" for a specific application. The recommended applications of an NEC Electronics product depend on its quality grade, as indicated below. Customers must check the quality grade of each NEC Electronics product before using it in a particular application.

"Standard": Computers, office equipment, communications equipment, test and measurement equipment, audio and visual equipment, home electronic appliances, machine tools, personal electronic equipment and industrial robots.

"Special": Transportation equipment (automobiles, trains, ships, etc.), traffic control systems, anti-disaster systems, anti-crime systems, safety equipment and medical equipment (not specifically designed for life support).

"Specific": Aircraft, aerospace equipment, submersible repeaters, nuclear reactor control systems, life support systems and medical equipment for life support, etc.

The quality grade of NEC Electronics products is "Standard" unless otherwise expressly specified in NEC Electronics data sheets or data books, etc. If customers wish to use NEC Electronics products in applications not intended by NEC Electronics, they must contact an NEC Electronics sales representative in advance to determine NEC Electronics' willingness to support a given application.

(Note)

- (1) "NEC Electronics" as used in this statement means NEC Electronics Corporation and also includes its majority-owned subsidiaries.
- (2) "NEC Electronics products" means any product developed or manufactured by or for NEC Electronics (as defined above).