

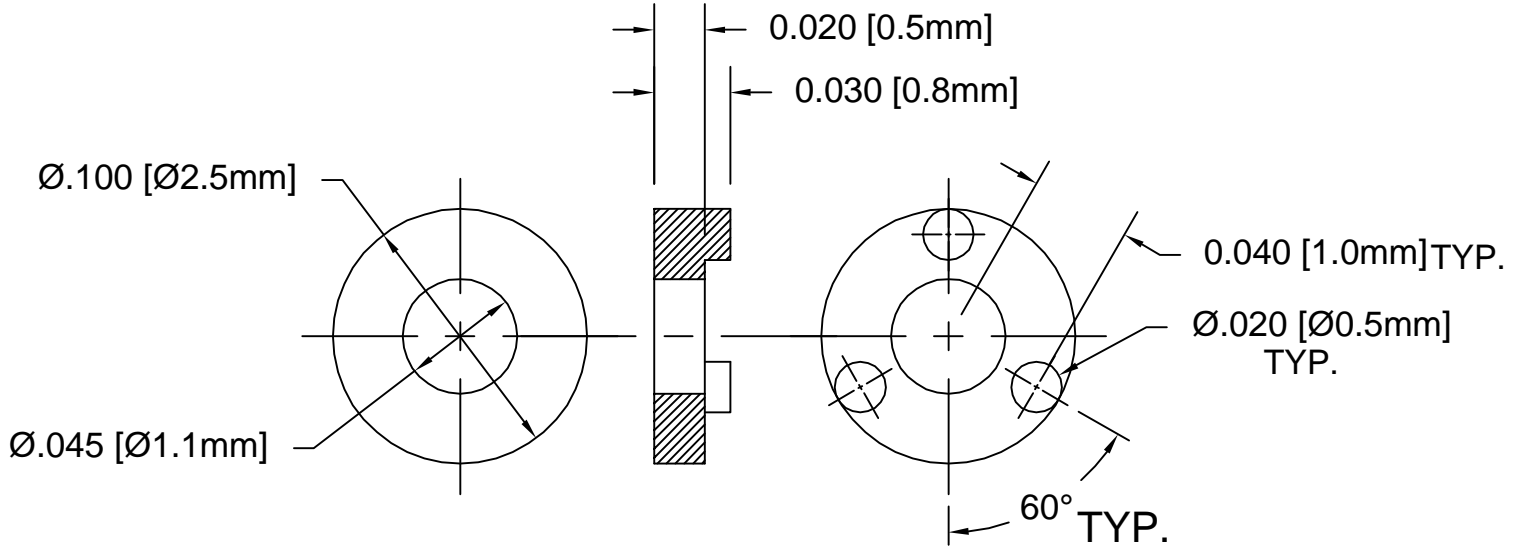

| REV. | DESCRIPTION                    | DATE     | APPROVED |
|------|--------------------------------|----------|----------|
| C    | Engineering Update w/o Changes | 02/20/04 | M. C.    |
|      |                                |          |          |
|      |                                |          |          |
|      |                                |          |          |



2. MATERIAL: NYLON 6/6, 94V-2, WHITE. BIVAR MATERIAL CODE 04-WE.  
 BASF ULTRAMID NYLON 6/6 A3K WHITE.
1. GENERAL SPECIFICATIONS: BIVAR MOLDED COMPONENT SPECIFICATION BV00-E101.

|  |         |   |                        |   |                   |                |
|--|---------|---|------------------------|---|-------------------|----------------|
| STANDARD TOLERANCE<br>( UNLESS OTHERWISE SPECIFIED ) |         | <br>4 THOMAS, IRVINE, CA. 92618<br>TEL: (949) 951-8808 FAX: (949) 951-3974 |                        |   |                   |                |
| DECIMALS   | ANGULAR |   |                        |   |                   |                |
| .X ± .1  | X° ± 1° |    | TITLE: PERM-O-PAD      |   |                   |                |
| .XX ± .01  |         |   | DESIGNED: Shane Irving | DATE: 05/12/98                                  | PART NO: 413-030  | REVISION: C    |
| .XXX ± .005  |         |   | CHECKED: D. Green      | DATE: 02/20/04                                  | CAGE CODE : 32559 | SHEET # 1 OF 1 |
|  |         |   |                        | CAD GENERATED DOCUMENT. DO NOT MEASURE DRAWING. |                   |                |