

# DATA SHEET

**UZZ9001**

**Sensor Conditioning Electronic**

Preliminary specification

2000 May 19

## Sensor Conditioning Electronic

## UZZ9001

## FEATURES

- One chip angle sensor output signal conditioning
- 180° angle range with KMZ41
- Accuracy better than 1° together with KMZ41
- Temperature range from –40 to +150 °C
- SPI protocol
- SO24 package.

## GENERAL DESCRIPTION

The UZZ9001 is an integrated circuit that combines two sinusoidal signals (sine and cosine) into one single linear output signal. These signals might come from the magnetoresistive sensor KMZ41. This results in a measurement system for angles up to 180°. The integrated circuit UZZ9001 can also be used for all other applications in which an angle has to be calculated from a sine and cosine signal. A typical application would be any kind of resolver application.

The two input signals are converted into the digital domain with two separate AD converters. A CORDIC algorithm performs the inverse tangent transformation. The output stage implements the Motorola Serial Peripheral Interface (SPI) protocol.

## PINNING

SYMBOL	PIN	DESCRIPTION
+V <sub>O2</sub>	1	sensor 2 positive differential input
+V <sub>O1</sub>	2	sensor 1 positive differential input
V <sub>DD2</sub>	3	digital supply voltage
V <sub>SS</sub>	4	digital ground
GND	5	analog ground
RST	6	reset of the digital part; note 1
TEST1	7	for production test; note 1
TEST2	8	note 2
DATA_CLK	9	trim-mode data-clock; note 1
SMODE	10	serial mode programmer; note 1
TEST3	11	note 2
data	12	SPI data output
CLK	13	SPI data clock in
CS	14	SPI chip select
OFFS2	15	offset trimming input sensor 2
OFFS1	16	offset trimming input sensor 1
V <sub>DDA</sub>	17	analog supply voltage
GND	18	analog ground
TEST4	19	for production test; note 1
TEST5	20	for production test; note 1
V <sub>DD1</sub>	21	digital supply voltage
T <sub>out</sub>	22	test output
–V <sub>O2</sub>	23	sensor 2 negative differential input
–V <sub>O1</sub>	24	sensor 1 negative differential input

## Notes

1. Connected to ground.
2. Pin to be left unconnected.

## QUICK REFERENCE DATA

SYMBOL	PARAMETER	CONDITIONS	MIN.	TYP.	MAX.	UNIT
V <sub>DDA</sub>	supply voltage	note 1	4.5	5	5.5	V
V <sub>DD1</sub>	supply voltage	note 1	4.5	5	5.5	V
V <sub>DD2</sub>	supply voltage	note 1	4.5	5	5.5	V
I <sub>CCtot</sub>	total supply current	no output load	–	5	15	mA
Res	resolution		–	13	–	bit
A	accuracy	with ideal input signal	±0.35	–	–	deg
I <sub>data-out</sub>	peak output current		–	–	10	mA

## Note

1. V<sub>DDA</sub>, V<sub>DD1</sub> and V<sub>DD2</sub> must be connected to the same supply voltage.

## Sensor Conditioning Electronic

UZZ9001

**LIMITING VALUES**

In accordance with the Absolute Maximum Rating System (IEC 60134).

SYMBOL	PARAMETER	CONDITIONS	MIN.	MAX.	UNIT
V <sub>DDA</sub>	supply voltage		-0.3	+6	V
V <sub>DD1</sub>	supply voltage		-0.3	+6	V
V <sub>DD2</sub>	supply voltage		-0.3	+6	V
V <sub>pin</sub>	voltage at all pins		-0.3	V <sub>DD</sub>	V
T <sub>stg</sub>	storage temperature		-55	+150	°C
T <sub>amb</sub>	operating temperature	125 to 150 °C; max 200 hours	-40	+150	°C

**THERMAL CHARACTERISTICS**

SYMBOL	PARAMETER	VALUE	UNIT
R <sub>th j-a</sub>	thermal resistance from junction to ambient	80	K/W

**ESD SENSITIVITY**

SYMBOL	PARAMETER	CONDITIONS	VALUE	UNIT
ESD	ESD sensitivity	human body model	2	kV
		machine model	±150	V

## Sensor Conditioning Electronic

## UZZ9001

**ELECTRICAL CHARACTERISTICS**

$T_{amb} = -40$  to  $+150$  °C;  $V_{DD} = 4.5$  to  $5.5$  V; typical characteristics for  $T_{amb} = 25$  °C and  $V_{DD} = 5$  V unless otherwise specified.

SYMBOL	PARAMETER	CONDITIONS	MIN.	TYP.	MAX.	UNIT
$V_{DDA}$	supply voltage		4.5	5	5.5	V
$V_{DD1}$	supply voltage		4.5	5	5.5	V
$V_{DD2}$	supply voltage		4.5	5	5.5	V
$I_{DD}$	supply current	without load	–	5	15	mA
$(+V_O)-(-V_O)$	differential input voltage	referred to $V_{DD}$	$\pm 6.6$	–	$\pm 28$	mV/V
	common mode range	referred to $V_{DD}$	490	–	510	mV/V
	lost magnet threshold	referred to $V_{DD}$	–	3	–	mV/V
$f_{ext}$	external clock frequency	for trim interface	0.1	–	1	MHz
$f_{int}$	internal clock frequency		2.3	4	5.7	MHz
$I_o$	data output	constant current	–	–	1	mA
		peak current	–	–	10	mA
$V_{reset}$	switching voltage threshold	between falling and rising $V_{DD}$	2.8	–	4.5	V
	hysteresis		–	0.3	–	V
A	accuracy	with ideal input signal	$\pm 0.35$	–	–	degree
Res	resolution		–	13	–	bit
$t_{on}$	power up time		–	–	20	ms
$t_r$	response time	to 95% of final value	–	0.7	1.2	ms
$V_{ID}$	digital input voltage	LO signal	0	–	$0.3 \times V_{DD}$	V
		HI signal	$0.7 \times V_{DD}$	–	$V_{DD}$	V
$V_{OD}$	digital output voltage	LO signal	–	–	0.4	V
		HI signal	$V_{DD} - 0.8$	–	–	V
$V_{LM}$	sensor voltage	lost magnet threshold	12	15	20	mV

**FUNCTIONAL DESCRIPTION**

The UZZ9001 is a mixed signal IC for angle measurement systems. It combines two analog signals (sine and cosine) into a linear output signal. The output stage implements the Motorola Serial Peripheral Interface (SPI) protocol. The UZZ9001 has been designed for use with the double sensor KMZ41.

The analog measurement signals on the IC input are converted to digital data with two ADC's. The ADC's are a Sigma-Delta modulator employing a 4th order continuous time architecture with an over-sampling ratio of 128 to achieve high resolution. The converter output is a digital bitstream with an over-sampling frequency of typically 500 kHz.

The bitstream is fed into a decimation filter which performs both low pass filtering and down-sampling. The IC has two input channels each of which has its own ADC and decimation filter. The two decimation filter outputs are 15-bit digital words at a lower frequency of typically 3.9 kHz which is the typical sampling frequency of the sensor system. The digital representations of the two signals are then used to calculate the current angle. This calculation is carried out using the so-called CORDIC algorithm. The angle is represented with a 13-bit resolution. An SPI compatible interface converts the output word to the serial peripheral interface protocol.

## Sensor Conditioning Electronic

## UZZ9001

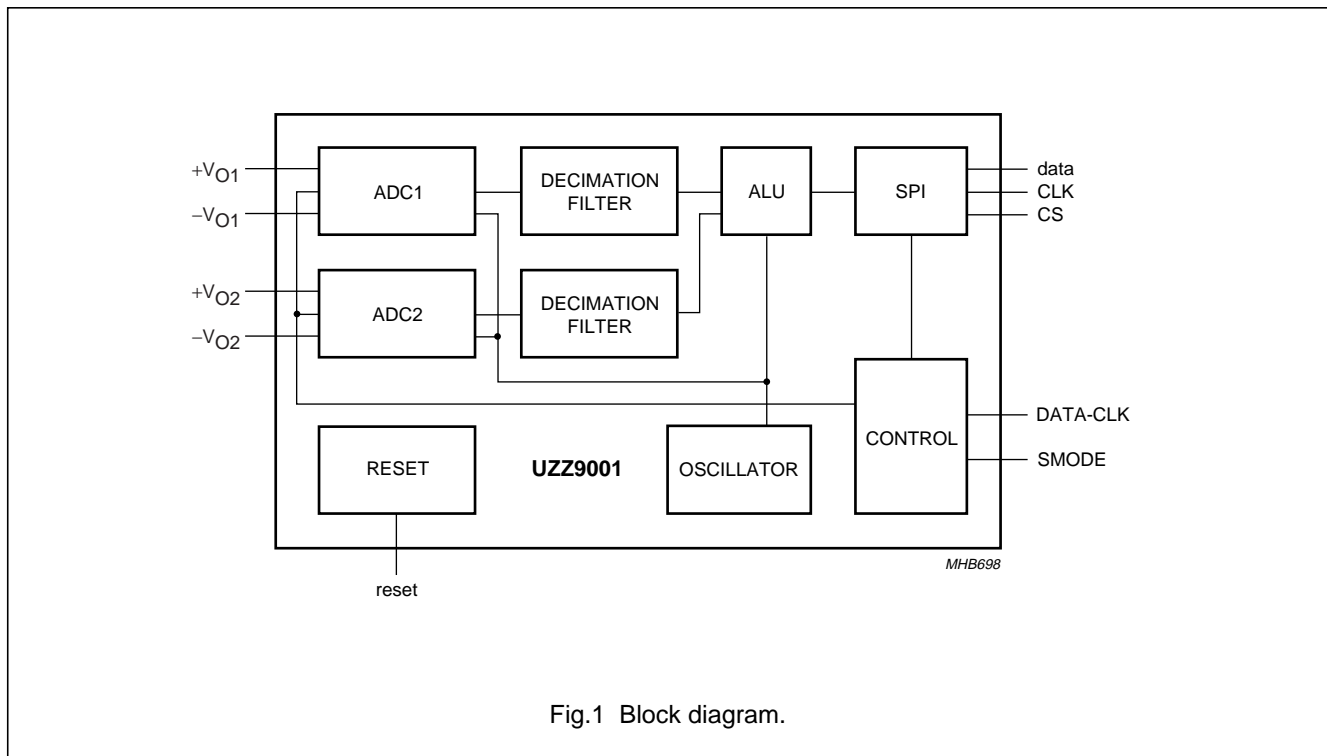

The following list gives a short description of the relevant block functions:

1. The ADC block contains two Sigma Delta AD converters, sensor offset correction circuitry and the circuitry required for the sensitivity and offset adjustment of the chip output voltage curve.
2. Two digital low pass decimation filters convert the low resolution high speed bit stream coming from the ADC Sigma Delta converters into a low speed digital word.
3. The ALU block derives an angle value from the two digital inputs using the CORDIC algorithm.
4. The SPI converts the output of the ALU block to a SPI compatible 16 bit word.
5. The CONTROL block provides the clock and the control signals for the chip.
6. The RESET block supplies a reset signal during power-up and power-down when the power supply is below a certain value.
7. The Oscillator unit generates the master clock.

### Serial Peripheral interface (SPI)

The UZZ9001 provides an interface to SPI compatible devices, and as a slave node functions in one operational mode only. For Motorola SPI devices, this mode is selected by setting CPHA to 1 and CPOL to 1. In this transfer mode, data bits are sampled by the master using the leading edge of the clock as shown in Figure 2. The falling edge indicates that the next data bit has to be provided by the slave device (shift operation). An advantage of this mode is that the CS input toggles only once between every two sensor data bytes (see Fig.3). Data transmission can be stopped by the user at any time. The leading edge of the CS input initialises the SPI shift register allowing the start of a complete new transmission. If the CS line is held active low during stop of transmission, resumption of transmission can be made without loss of data

Sensor Conditioning Electronic

UZZ9001

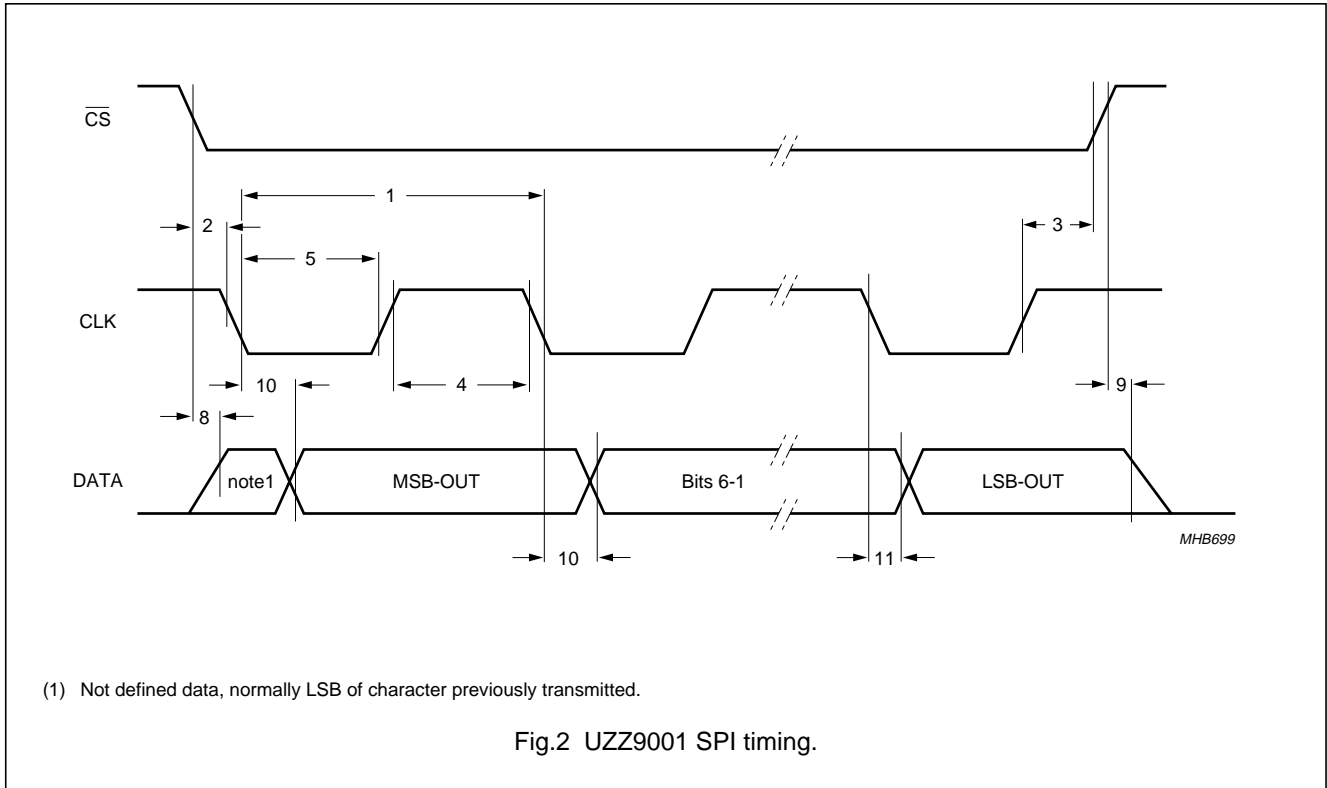

Fig.2 UZZ9001 SPI timing.

Table 1 SPI-Timing

DIAGRAM NUMBER	PARAMETER	SYMBOL	MIN.	MAX.	UNIT	REMARKS/TEST CONDITIONS
1	cycle time	$t_{cyc}$	1	—	$\mu s$	
2	enable lead time	$t_{lead}$	15	—	ns	determined by master module
3	enable lag time	$t_{lag}$	15	—	ns	determined by master module
4	clock high time	$t_{clk\_high}$	100	—	ns	determined by master module
5	clock low time	$t_{clk\_low}$	100	—	ns	determined by master module
8	access time	$t_{acc}$	0	20	ns	time to data active from fixed $V_{SS}$ state
9	disable time	$t_{dis}$	—	25	ns	hold time to fixed $V_{SS}$ state
10	data valid time (after clock edge)	$t_v$	—	40	ns	with 100 pF on all SPI pins
11	data hold time (output, after clock edge)	$t_h$	5	—	ns	
	operating frequency	$f_{op}$	—	1	MHz	
	transmission delay (time between the leading edge of CS until the next falling edge)	$t_{delay}$	1.2	—	$\mu s$	

Sensor Conditioning Electronic

UZZ9001

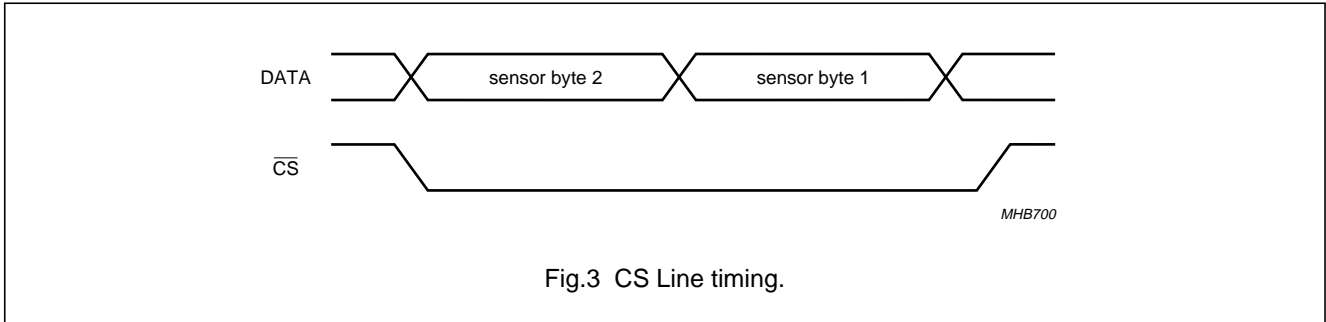

Fig.3 CS Line timing.

**Sensor signal coding**

The sensor signal comprises 14 bits (D13 to D0) as shown in Fig.4. Bits D12 to D0 are used for the coding of the angle while D0 is reserved to indicate error and diagnostic conditions as defined below. The 14 data bits are arranged in 2 Bytes. D13 is the MSB of the sensor signal and D0 is the LSB of the sensor signal. Byte 2, which is sent first, contains data bits D13 to D7 and additionally the parity bit P2 which is included for the recognition of interrupted messages. P2 gives the ODD parity of data bits D13 to D7 and has to be evaluated by the master module. Similarly, Byte 1 comprises data bits D6 to D0 and parity bit P1, which gives the ODD parity of data bits D6 to D0. The internal coding of angle values is as follows:

$$00\ 0000\ 0000\ 0000_B = 0^\circ, 180^\circ$$

$$\begin{matrix} 01 & 1111 & 1111 & 1111_B & = & (2^{13} - 1) \frac{180^\circ}{2^{13}} \approx 179.978 \\ \text{D13} & & & \text{D0} & & \end{matrix}$$

During normal operation, bit D13 is active low. Each increment represents an angle value

$$\text{of: } \alpha_{inc} = \frac{180^\circ}{2^{13}} \approx 0.022^\circ$$

The error and diagnostic conditions are indicated by D13 = 1 (active high). In an error situation the last two bits (D0 and D1) specify the error code (see Table 2). All other bits (D3 to D12) still show the current measurement value, but as the last two bits are lost for measurement representation the resolution is reduced to 11 bit.

**Table 2** Error and diagnostic cases coding

D1	D0	CASE	MEASUREMENT VALUE RELIABLE
0	0	no valid value presently available due to RESET	no
0	1	magnet lost	no
1	0	reserved	-
1	1	reserved	-

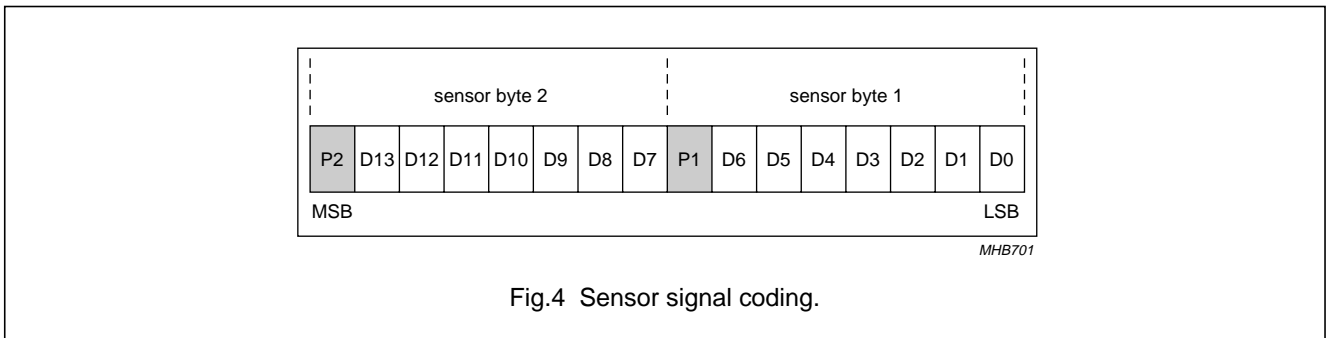

Fig.4 Sensor signal coding.

Sensor Conditioning Electronic

UZZ9001

**Magnet lost condition**

If both offset corrected input signal of sensor 1 and sensor 2 are below the lost magnet threshold then the failure 'Magnet lost' is assumed.

**Offset trimming**

To achieve a linear output characteristic, it is necessary to shift the offsets of the two input signals to the input stage of the UZZ9001. For this reason a sensor offset cancellation procedure has been implemented in the UZZ9001 which is started by sending a special serial data protocol to the UZZ9001. This trimming procedure is required for both input signals.

**Trim interface**

The UZZ9001 trim mode serial interface consists of the two terminals SMODE (pin 10) and DATA\_CLK (pin 9). The structure of this protocol is shown in Figure 5. All signal levels of DATA\_CLK and SMODE must lie within the ranges set out in Table 3. The protocol starts with a falling edge at the SMODE, which must occur at a high DATA\_CLK level. The following five bits are used to code the message sent to the UZZ9001. They are transferred via the SMODE and are sampled with the rising edge of the DATA\_CLK. During the fifth high level output of DATA\_CLK (counted from the start condition onwards), a rising edge must appear at the SMODE and the DATA\_CLK follows this with one more change to low level in order to successfully complete the protocol.

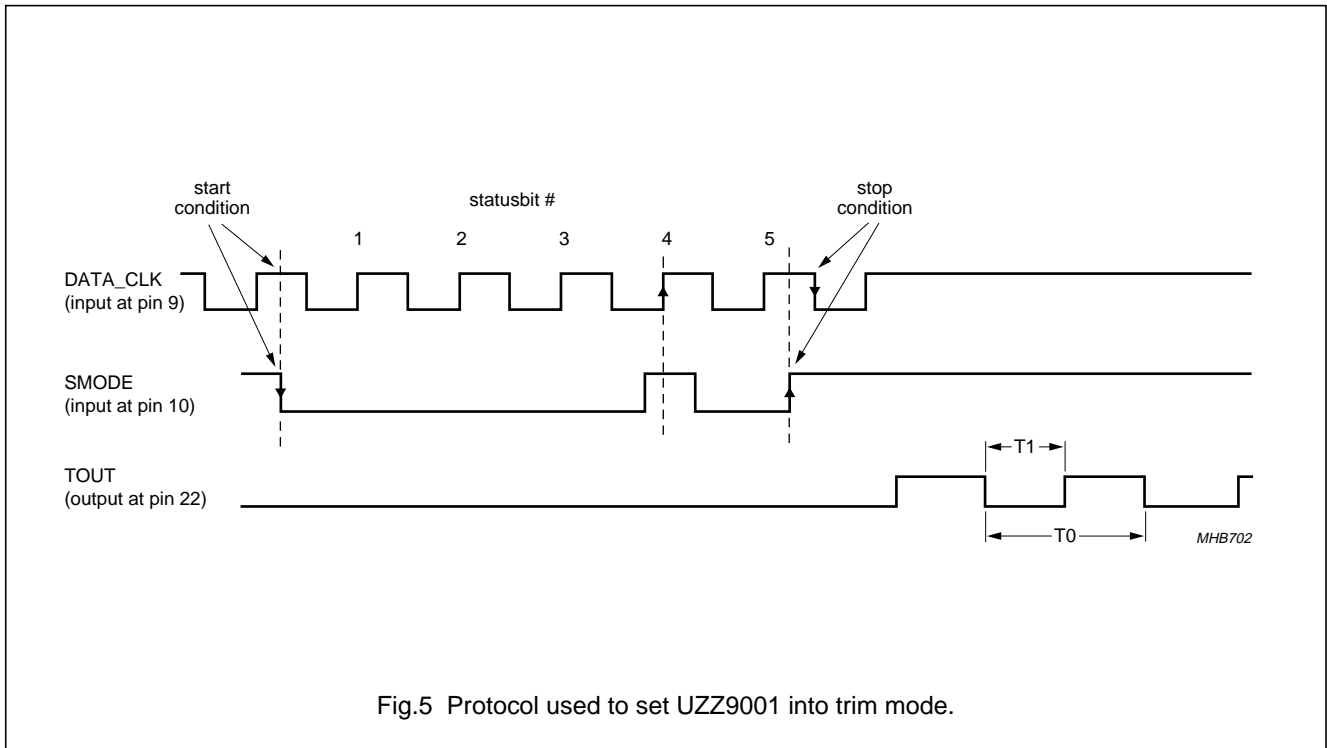

Fig.5 Protocol used to set UZZ9001 into trim mode.

**Table 3** Definition of the trim interface signals

PARAMETER	MIN.	MAX.	UNIT
low level of DATA_CLK, SMODE	0	5	%V <sub>DD</sub>
high level of DATA_CLK, SMODE	95	100	%V <sub>DD</sub>
rise and fall time of DATA_CLK and SMODE signal edges (10 to 90% V <sub>DD</sub> ) and (90 to 10% V <sub>DD</sub> )	8	–	ns
DATA_CLK frequency	0.1	1	MHz



# Sensor Conditioning Electronic

# UZZ9001

**Table 4** Programming of trim modes

MODE	STATUS BITS				
	1	2	3	4	5
enter trim mode for sensor input channel 1	0	0	0	1	0
enter trim mode for sensor input channel 2	0	0	1	0	0
leave trim mode for either input channel	0	0	0	0	0

### How to enter the trim mode

Details of voltage levels and timing of the status bits to be transmitted to the UZZ9001 are given in Table 3. Note that a complete protocol has to be sent before normal operation can be resumed. The trim mode can also be exited by resetting the device. After entering one of the trim modes and provided there is a dynamic input signal there will be a square wave output at the terminal T<sub>OUT</sub> (pin 22).

### Reset

In addition to the external reset pin (pin 6), the UZZ9001 provides an internal power-up/ power-down reset logic which continuously monitors the supply voltage. When the supply voltage increases and reaches a safe level, reset becomes inactive and the device starts initialization. When the supply voltage exceeds the safe voltage level, the device is reset immediately. This internal reset logic can be over-ridden in all modes and at any time by applying an external active high command to the RES input pin (pin 6) in all modes and at any time. The reset pin RES (pin 6). This pin is internally pulled to ground and therefore need not be connected if the function is not required.

### Measurement dynamics

The UZZ9001 includes an on-chip RC Oscillator that generates the clock for the whole device. Consequently, no external clock supply is required for the measurement system. The nominal clock frequency of the on-chip oscillator is 4 MHz at room temperature. It varies with temperature change. At -40 °C the clock frequency may decrease to 2.3 MHz. At higher temperatures however, a frequency up to 5.7 MHz may occur. This influences the dynamics of measurements. From an application point of view, two different effects have to be distinguished. The system delay, which means how long it takes until a changed input signal is recognized at the output, and the measurement update rate. The system delay is mainly caused by the settling time of the low pass decimation filter, which depends on the maximum frequency content (shape) of the input signals and the clock frequency. The following maximum values can be expected for the entire system delay. The measurement update rate, however, is directly related to the oscillator frequency. At room temperature, a new value is available every 0.26 ms. When taking the entire temperature range into account, update rates between 0.45 and 0.18 ms are possible. (see Table 5)

# Sensor Conditioning Electronic

# UZZ9001

**Table 5** System delay and update rates of the UZZ9001

PARAMETER	MIN.	TYP.	MAX.	UNIT
System delay (time elapsed until 95% of the final value is reached)				
max. signal frequency < 200 MHz	–	–	0.6	ms
transients (step response)	–	–	1.2	ms
Measurement update rate				
–40 °C	0.45	–	–	ms
+25 °C (room temperature)	–	0.26	–	ms
+150 °C	–	–	0.18	ms

## APPLICATION INFORMATION

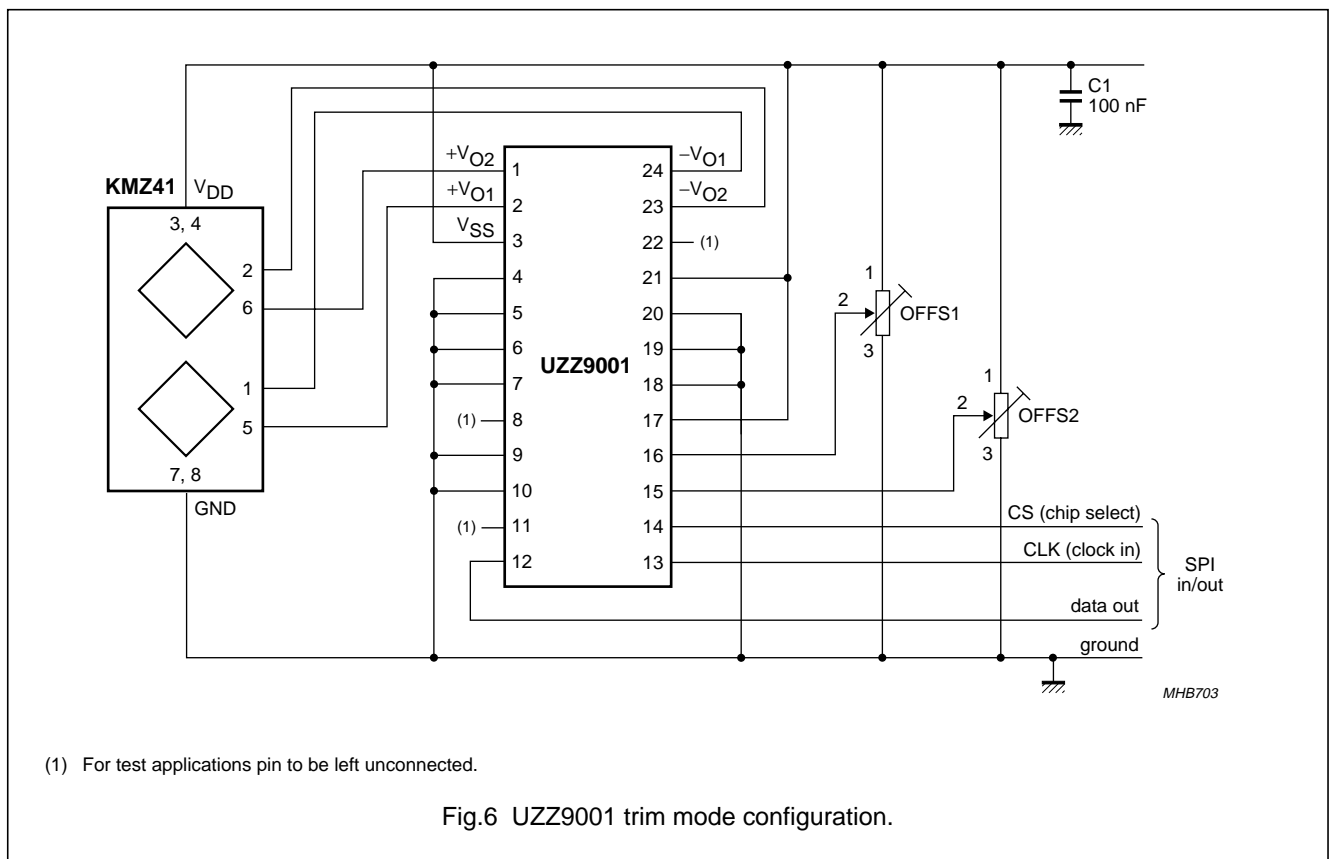

Sensor Conditioning Electronic

UZZ9001

PACKAGE OUTLINE

SO24: plastic small outline package; 24 leads; body width 7.5 mm

SOT137-1

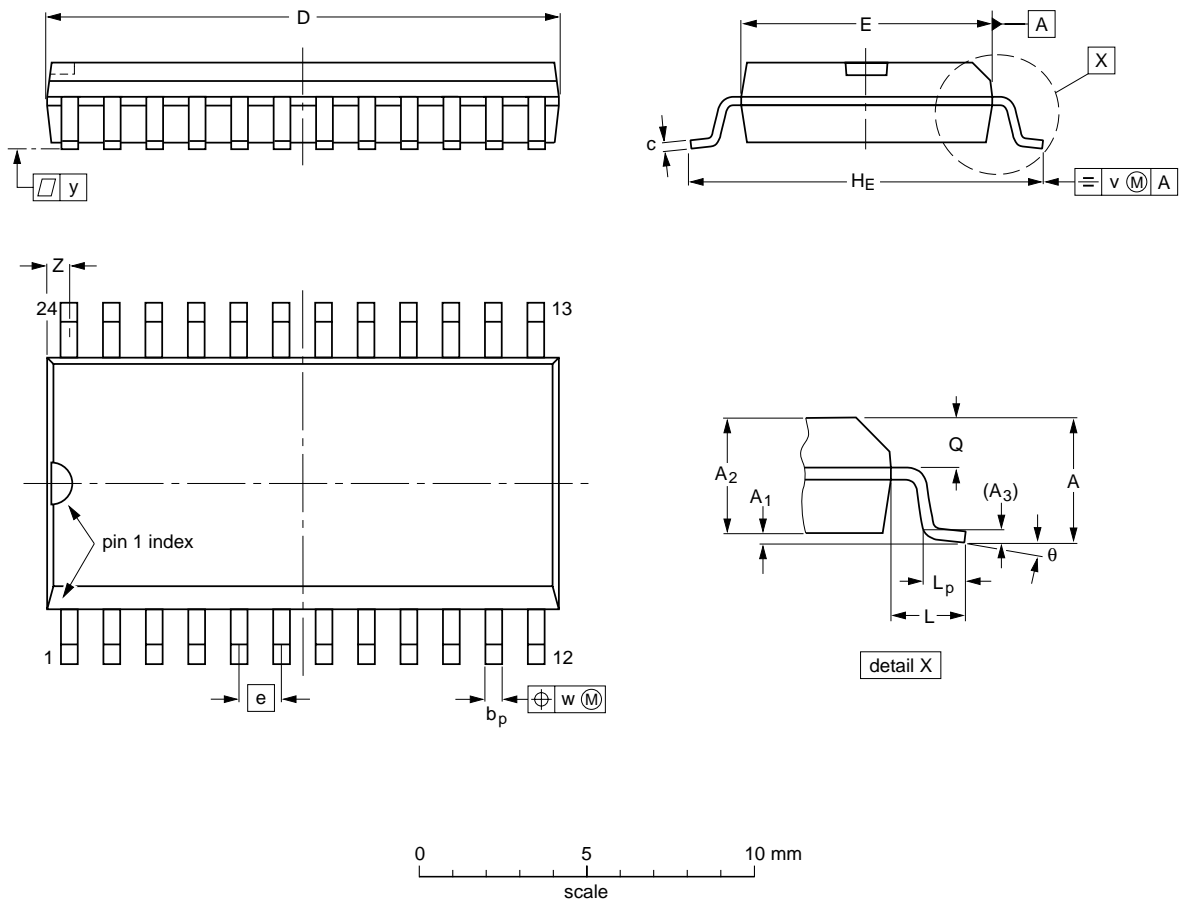

DIMENSIONS (inch dimensions are derived from the original mm dimensions)

UNIT	A max.	A <sub>1</sub>	A <sub>2</sub>	A <sub>3</sub>	b <sub>p</sub>	c	D <sup>(1)</sup>	E <sup>(1)</sup>	e	H <sub>E</sub>	L	L <sub>p</sub>	Q	v	w	y	z <sup>(1)</sup>	θ
mm	2.65	0.30 0.10	2.45 2.25	0.25	0.49 0.36	0.32 0.23	15.6 15.2	7.6 7.4	1.27	10.65 10.00	1.4	1.1 0.4	1.1 1.0	0.25	0.25	0.1	0.9 0.4	8° 0°
inches	0.10	0.012 0.004	0.096 0.089	0.01	0.019 0.014	0.013 0.009	0.61 0.60	0.30 0.29	0.050	0.419 0.394	0.055	0.043 0.016	0.043 0.039	0.01	0.01	0.004	0.035 0.016	

Note

1. Plastic or metal protrusions of 0.15 mm maximum per side are not included.

OUTLINE VERSION	REFERENCES				EUROPEAN PROJECTION	ISSUE DATE
	IEC	JEDEC	EIAJ			
SOT137-1	075E05	MS-013				97-05-22 99-12-27

## Sensor Conditioning Electronic

UZZ9001

## DATA SHEET STATUS

DATA SHEET STATUS	PRODUCT STATUS	DEFINITIONS <sup>(1)</sup>
Objective specification	Development	This data sheet contains the design target or goal specifications for product development. Specification may change in any manner without notice.
Preliminary specification	Qualification	This data sheet contains preliminary data, and supplementary data will be published at a later date. Philips Semiconductors reserves the right to make changes at any time without notice in order to improve design and supply the best possible product.
Product specification	Production	This data sheet contains final specifications. Philips Semiconductors reserves the right to make changes at any time without notice in order to improve design and supply the best possible product.

## Note

1. Please consult the most recently issued data sheet before initiating or completing a design.

## DEFINITIONS

**Short-form specification** — The data in a short-form specification is extracted from a full data sheet with the same type number and title. For detailed information see the relevant data sheet or data handbook.

**Limiting values definition** — Limiting values given are in accordance with the Absolute Maximum Rating System (IEC 60134). Stress above one or more of the limiting values may cause permanent damage to the device. These are stress ratings only and operation of the device at these or at any other conditions above those given in the Characteristics sections of the specification is not implied. Exposure to limiting values for extended periods may affect device reliability.

**Application information** — Applications that are described herein for any of these products are for illustrative purposes only. Philips Semiconductors make no representation or warranty that such applications will be suitable for the specified use without further testing or modification.

## DISCLAIMERS

**Life support applications** — These products are not designed for use in life support appliances, devices, or systems where malfunction of these products can reasonably be expected to result in personal injury. Philips Semiconductors customers using or selling these products for use in such applications do so at their own risk and agree to fully indemnify Philips Semiconductors for any damages resulting from such application.

**Right to make changes** — Philips Semiconductors reserves the right to make changes, without notice, in the products, including circuits, standard cells, and/or software, described or contained herein in order to improve design and/or performance. Philips Semiconductors assumes no responsibility or liability for the use of any of these products, conveys no licence or title under any patent, copyright, or mask work right to these products, and makes no representations or warranties that these products are free from patent, copyright, or mask work right infringement, unless otherwise specified.

Sensor Conditioning Electronic

UZZ9001

---

**NOTES**

Sensor Conditioning Electronic

UZZ9001

---

**NOTES**

# Sensor Conditioning Electronic

UZZ9001

---

## NOTES

# Philips Semiconductors – a worldwide company

**Argentina:** see South America

**Australia:** 3 Figtree Drive, HOMEBUSH, NSW 2140,  
Tel. +61 2 9704 8141, Fax. +61 2 9704 8139

**Austria:** Computerstr. 6, A-1101 WIEN, P.O. Box 213,  
Tel. +43 1 60 101 1248, Fax. +43 1 60 101 1210

**Belarus:** Hotel Minsk Business Center, Bld. 3, r. 1211, Volodarski Str. 6,  
220050 MINSK, Tel. +375 172 20 0733, Fax. +375 172 20 0773

**Belgium:** see The Netherlands

**Brazil:** see South America

**Bulgaria:** Philips Bulgaria Ltd., Energoproject, 15th floor,  
51 James Bourchier Blvd., 1407 SOFIA,  
Tel. +359 2 68 9211, Fax. +359 2 68 9102

**Canada:** PHILIPS SEMICONDUCTORS/COMPONENTS,  
Tel. +1 800 234 7381, Fax. +1 800 943 0087

**China/Hong Kong:** 501 Hong Kong Industrial Technology Centre,  
72 Tat Chee Avenue, Kowloon Tong, HONG KONG,  
Tel. +852 2319 7888, Fax. +852 2319 7700

**Colombia:** see South America

**Czech Republic:** see Austria

**Denmark:** Sydhavnsgade 23, 1780 COPENHAGEN V,  
Tel. +45 33 29 3333, Fax. +45 33 29 3905

**Finland:** Sinikalliontie 3, FIN-02630 ESPOO,  
Tel. +358 9 615 800, Fax. +358 9 6158 0920

**France:** 51 Rue Carnot, BP317, 92156 SURESNES Cedex,  
Tel. +33 1 4099 6161, Fax. +33 1 4099 6427

**Germany:** Hammerbrookstraße 69, D-20097 HAMBURG,  
Tel. +49 40 2353 60, Fax. +49 40 2353 6300

**Hungary:** see Austria

**India:** Philips INDIA Ltd, Band Box Building, 2nd floor,  
254-D, Dr. Annie Besant Road, Worli, MUMBAI 400 025,  
Tel. +91 22 493 8541, Fax. +91 22 493 0966

**Indonesia:** PT Philips Development Corporation, Semiconductors Division,  
Gedung Philips, Jl. Buncit Raya Kav.99-100, JAKARTA 12510,  
Tel. +62 21 794 0040 ext. 2501, Fax. +62 21 794 0080

**Ireland:** Newstead, Clonskeagh, DUBLIN 14,  
Tel. +353 1 7640 000, Fax. +353 1 7640 200

**Israel:** RAPAC Electronics, 7 Kehilat Saloniki St, PO Box 18053,  
TEL AVIV 61180, Tel. +972 3 645 0444, Fax. +972 3 649 1007

**Italy:** PHILIPS SEMICONDUCTORS, Via Casati, 23 - 20052 MONZA (MI),  
Tel. +39 039 203 6838, Fax +39 039 203 6800

**Japan:** Philips Bldg 13-37, Kohnan 2-chome, Minato-ku,  
TOKYO 108-8507, Tel. +81 3 3740 5130, Fax. +81 3 3740 5057

**Korea:** Philips House, 260-199 Itaewon-dong, Yongsan-ku, SEOUL,  
Tel. +82 2 709 1412, Fax. +82 2 709 1415

**Malaysia:** No. 76 Jalan Universiti, 46200 PETALING JAYA, SELANGOR,  
Tel. +60 3 750 5214, Fax. +60 3 757 4880

**Mexico:** 5900 Gateway East, Suite 200, EL PASO, TEXAS 79905,  
Tel. +9-5 800 234 7381, Fax +9-5 800 943 0087

**Middle East:** see Italy

**Netherlands:** Postbus 90050, 5600 PB EINDHOVEN, Bldg. VB,  
Tel. +31 40 27 82785, Fax. +31 40 27 88399

**New Zealand:** 2 Wagener Place, C.P.O. Box 1041, AUCKLAND,  
Tel. +64 9 849 4160, Fax. +64 9 849 7811

**Norway:** Box 1, Manglerud 0612, OSLO,  
Tel. +47 22 74 8000, Fax. +47 22 74 8341

**Pakistan:** see Singapore

**Philippines:** Philips Semiconductors Philippines Inc.,  
106 Valero St. Salcedo Village, P.O. Box 2108 MCC, MAKATI,  
Metro MANILA, Tel. +63 2 816 6380, Fax. +63 2 817 3474

**Poland:** Al.Jerozolimskie 195 B, 02-222 WARSAW,  
Tel. +48 22 5710 000, Fax. +48 22 5710 001

**Portugal:** see Spain

**Romania:** see Italy

**Russia:** Philips Russia, Ul. Usatcheva 35A, 119048 MOSCOW,  
Tel. +7 095 755 6918, Fax. +7 095 755 6919

**Singapore:** Lorong 1, Toa Payoh, SINGAPORE 319762,  
Tel. +65 350 2538, Fax. +65 251 6500

**Slovakia:** see Austria

**Slovenia:** see Italy

**South Africa:** S.A. PHILIPS Pty Ltd., 195-215 Main Road Martindale,  
2092 JOHANNESBURG, P.O. Box 58088 Newville 2114,  
Tel. +27 11 471 5401, Fax. +27 11 471 5398

**South America:** Al. Vicente Pinzon, 173, 6th floor,  
04547-130 SÃO PAULO, SP, Brazil,  
Tel. +55 11 821 2333, Fax. +55 11 821 2382

**Spain:** Balmes 22, 08007 BARCELONA,  
Tel. +34 93 301 6312, Fax. +34 93 301 4107

**Sweden:** Kottbygatan 7, Akalla, S-16485 STOCKHOLM,  
Tel. +46 8 5985 2000, Fax. +46 8 5985 2745

**Switzerland:** Allmendstrasse 140, CH-8027 ZÜRICH,  
Tel. +41 1 488 2741 Fax. +41 1 488 3263

**Taiwan:** Philips Semiconductors, 6F, No. 96, Chien Kuo N. Rd., Sec. 1,  
TAIPEI, Taiwan Tel. +886 2 2134 2886, Fax. +886 2 2134 2874

**Thailand:** PHILIPS ELECTRONICS (THAILAND) Ltd.,  
209/2 Sanpavuth-Bangna Road Prakanong, BANGKOK 10260,  
Tel. +66 2 745 4090, Fax. +66 2 398 0793

**Turkey:** Yukari Dudullu, Org. San. Blg., 2.Cad. Nr. 28 81260 Umraniye,  
ISTANBUL, Tel. +90 216 522 1500, Fax. +90 216 522 1813

**Ukraine:** PHILIPS UKRAINE, 4 Patrice Lumumba str., Building B, Floor 7,  
252042 KIEV, Tel. +380 44 264 2776, Fax. +380 44 268 0461

**United Kingdom:** Philips Semiconductors Ltd., 276 Bath Road, Hayes,  
MIDDLESEX UB3 5BX, Tel. +44 208 730 5000, Fax. +44 208 754 8421

**United States:** 811 East Arques Avenue, SUNNYVALE, CA 94088-3409,  
Tel. +1 800 234 7381, Fax. +1 800 943 0087

**Uruguay:** see South America

**Vietnam:** see Singapore

**Yugoslavia:** PHILIPS, Trg N. Pasica 5/v, 11000 BEOGRAD,  
Tel. +381 11 3341 299, Fax.+381 11 3342 553

**For all other countries apply to:** Philips Semiconductors,  
International Marketing & Sales Communications, Building BE-p, P.O. Box 218,  
5600 MD EINDHOVEN, The Netherlands, Fax. +31 40 27 24825

**Internet:** <http://www.semiconductors.philips.com>

© Philips Electronics N.V. 2000

SCA 69

All rights are reserved. Reproduction in whole or in part is prohibited without the prior written consent of the copyright owner.

The information presented in this document does not form part of any quotation or contract, is believed to be accurate and reliable and may be changed without notice. No liability will be accepted by the publisher for any consequence of its use. Publication thereof does not convey nor imply any license under patent- or other industrial or intellectual property rights.

Printed in The Netherlands

613520/525/01/pp16

Date of release: 2000 May 19

Document order number: 9397 750 07016

*Let's make things better.*

**Philips**  
Semiconductors



**PHILIPS**