

BIPOLAR ANALOG INTEGRATED CIRCUIT

μ PC324

LOW POWER QUAD OPERATIONAL AMPLIFIER

DESCRIPTION

The μ PC324 is a quad operational amplifier which is designed to operate from a single power supply over a wide range of voltages. Operation from split power supplies is also possible and the power supply current drain is very low. Further advantage, the input common-mode voltage can also swing to ground in the linear mode.

FEATURES

- Internal frequency compensation
- Wide output voltage swing V^- to $V^+ - 1.5$ V
- Common Mode input voltage range includes V^-
- Wide supply range
 3 V to 30 V (Single)
 ± 1.5 V to ± 15 V (Split)
- Output short circuit protection

EQUIVALENT CIRCUIT (1/4 Circuit)

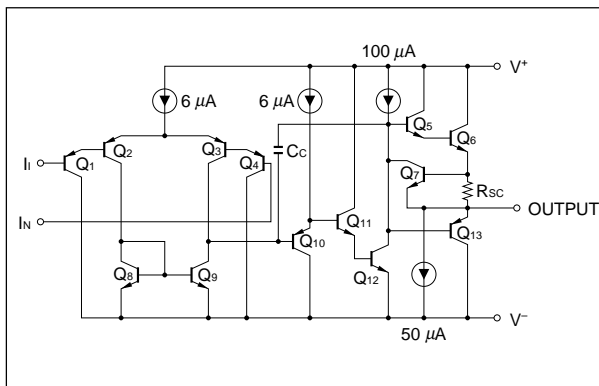

PIN CONFIGURATION (Top View)

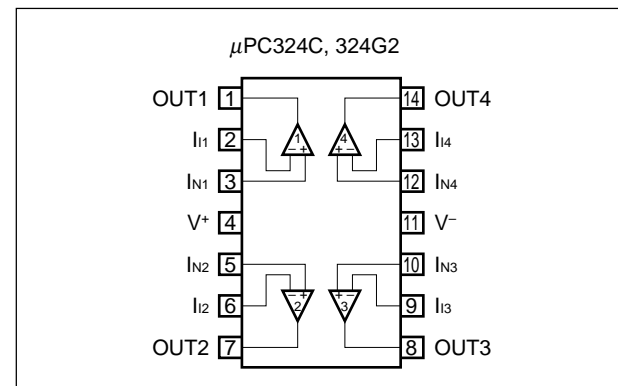

ORDERING INFORMATION

Part Number	Package
μ PC324C	14-pin plastic DIP (300 mil)
μ PC324G2	14-pin plastic SOP (225 mil)

The information in this document is subject to change without notice.

ABSOLUTE MAXIMUM RATINGS (TA = 25 °C)

Parameter		Symbol	Ratings	Unit
Voltage between V+ and V- Note 1		V+–V-	–0.3 to +32	V
Differential Input Voltage		V _{ID}	±32	V
Input Voltage Note 2		V _I	V–0.3 to V+32	V
Output Voltage Note 3		V _O	V–0.3 to V++0.3	V
Power Dissipation	C Package Note 4	P _T	570	mW
	G2 Package Note 5		550	mW
Output Short Circuit Duration Note 6			Indefinite	sec
Operating Ambient Temperature		T _A	–20 to +80	°C
Storage Temperature		T _{stg}	–55 to + 125	°C

- Notes**
- Reverse connection of supply voltage can cause destruction.
 - The input voltage should be allowed to input without damage or destruction independent of the magnitude of V+. Either input signal should not be allowed to go negative by more than 0.3 V. The normal operation will establish when the both inputs are within the Common Mode Input Voltage Range of electrical characteristics.
 - This specification is the voltage which should be allowed to supply to the output terminal from external without damage or destructive. Even during the transition period of supply voltage, power on/off etc., this specification should be kept. The output voltage of normal operation will be the Output Voltage Swing of electrical characteristics.
 - Thermal derating factor is –7.6 mW/°C when operating ambient temperature is higher than 50 °C.
 - Thermal derating factor is –5.5 mW/°C when operating ambient temperature is higher than 25 °C.
 - Pay careful attention to the total power dissipation not to exceed the absolute maximum ratings, Note 4 and Note 5.

RECOMMENDED OPERATING CONDITIONS

Parameter	Symbol	MIN.	TYP.	MAX.	Unit
Supply Voltage (Split)	V±	±1.5		±15	V
Supply Voltage (V– = GND)	V+	3		30	V

ELECTRICAL CHARACTERISTICS (TA = 25 °C, V+ = 5 V, V– = GND)

Parameter	Symbol	Conditions	MIN.	TYP.	MAX.	Unit
Input Offset Voltage	V _{IO}	R _S = 0 Ω		±2	±7	mV
Input Offset Current	I _{IO}			±5	±50	nA
Input Bias Current Note 7	I _B			45	250	nA
Large Single Voltage Gain	A _V	R _L ≥ 2 kΩ	25	100		V/mV
★ Supply Current	I _{CC}	R _L = ∞, I _O = 0 A, All Amplifiers		1.0	2	mA
Common Mode Rejection Ratio	CMR		65	85		dB
Supply Voltage Rejection Ratio	SVR		65	100		dB
Output Voltage Swing	V _O	R _L = 2 kΩ (Connect to GND)	0		V+ – 1.5	V
Common Mode Input Voltage Range	V _{ICM}		0		V+ – 1.5	V
Output Current (SOURCE)	I _{O SOURCE}	V _{IN+} = +1 V, V _{IN–} = 0 V	20	40		mA
Output Current (SINK)	I _{O SINK}	V _{IN–} = +1 V, V _{IN+} = 0 V	10	20		mA
		V _{IN–} = +1 V, V _{IN+} = 0 V, V _O = 200 mV	12	50		μA
Channel Separation		f = 1 kHz to 20 kHz		120		dB

- Notes**
- Input bias currents flow out from IC. Because each currents are base current of PNP-transistor on input stage.

TYPICAL PERFORMANCE CHARACTERISTICS (T_A = 25 °C, TYP.)

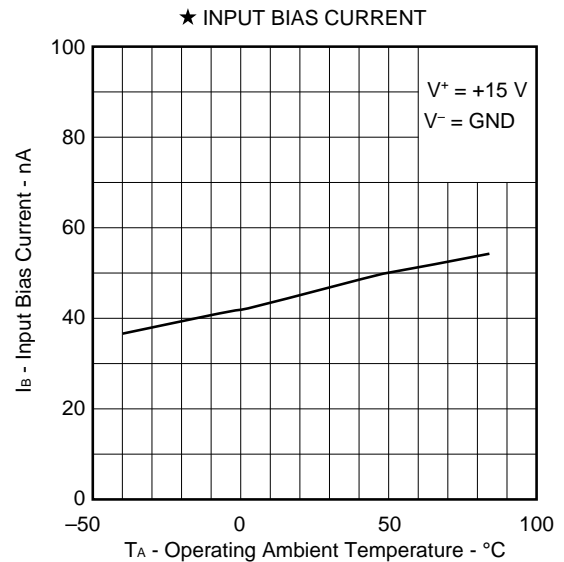
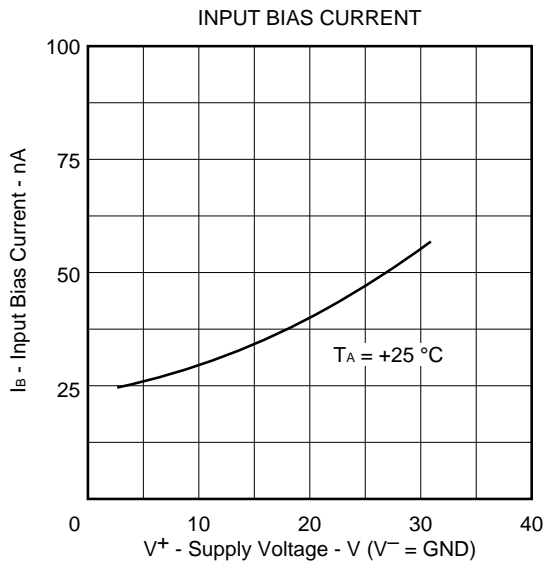
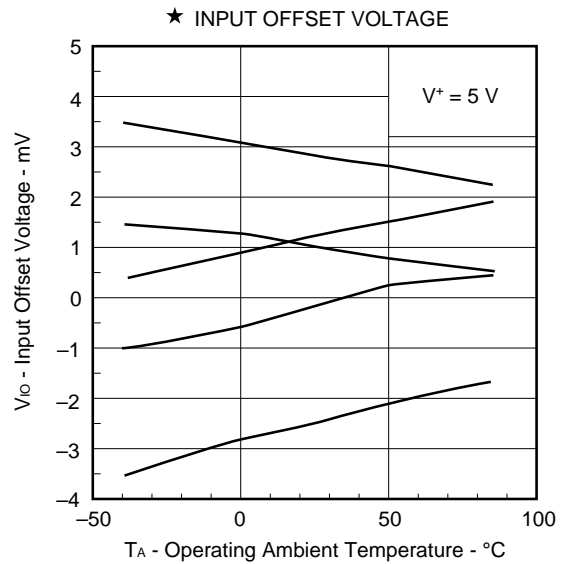
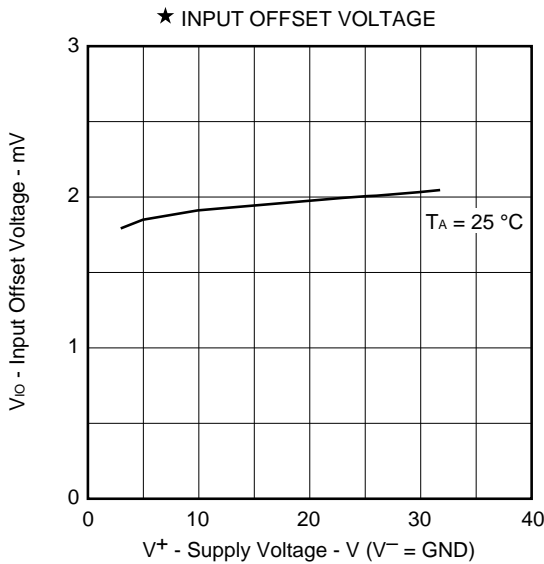
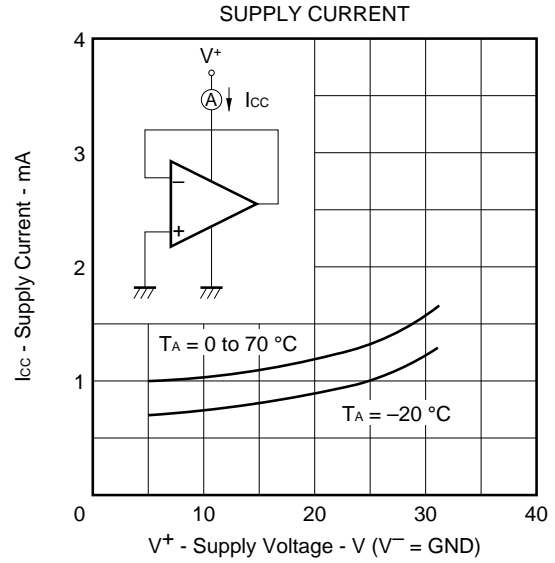
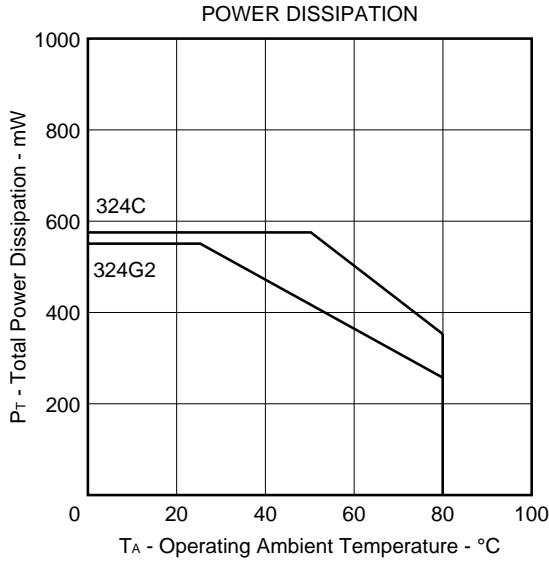

OUTPUT SINK CURRENT LIMIT

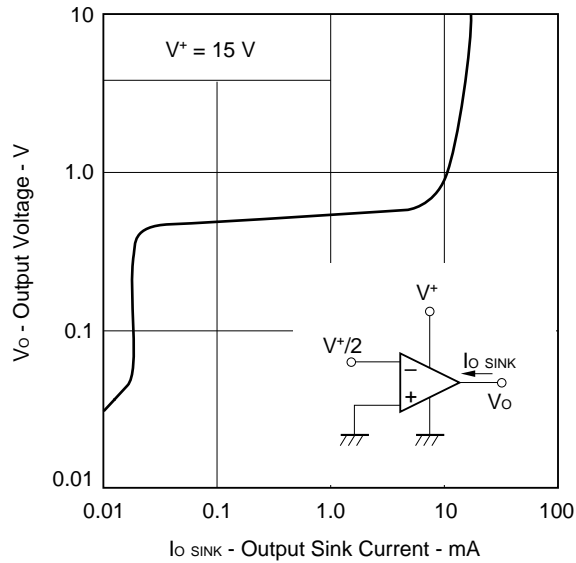

OUTPUT SOURCE CURRENT LIMIT

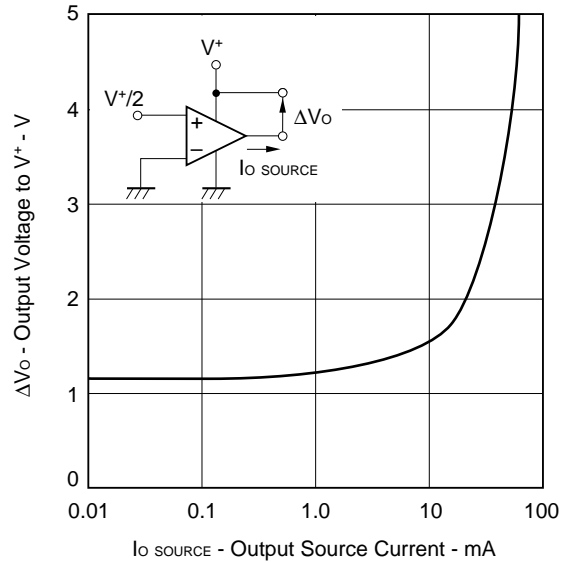

OUTPUT SHORT CIRCUIT CURRENT

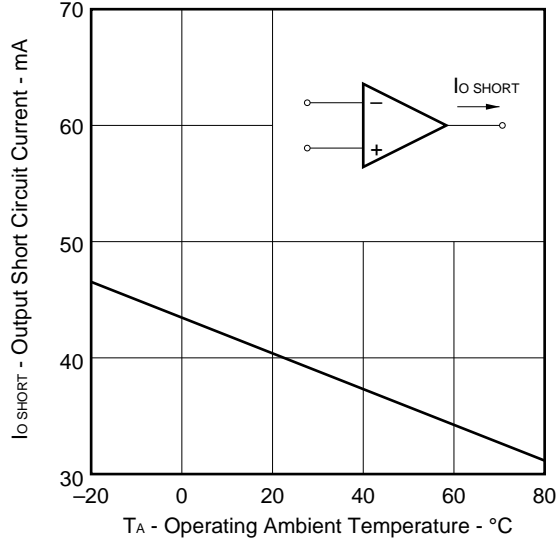

OPEN LOOP FREQUENCY RESPONSE

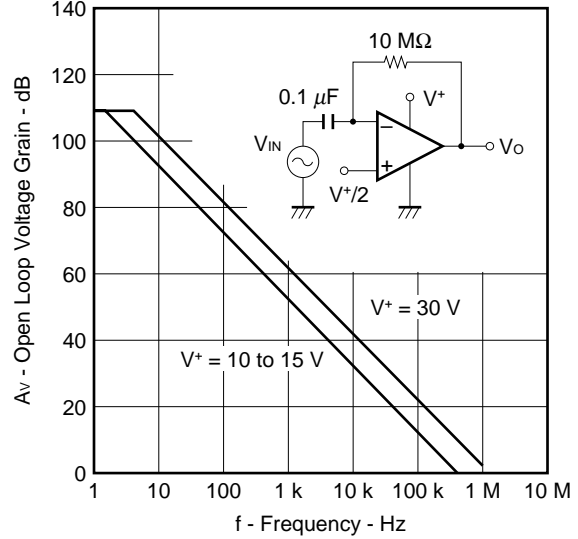

OPEN LOOP VOLTAGE GAIN

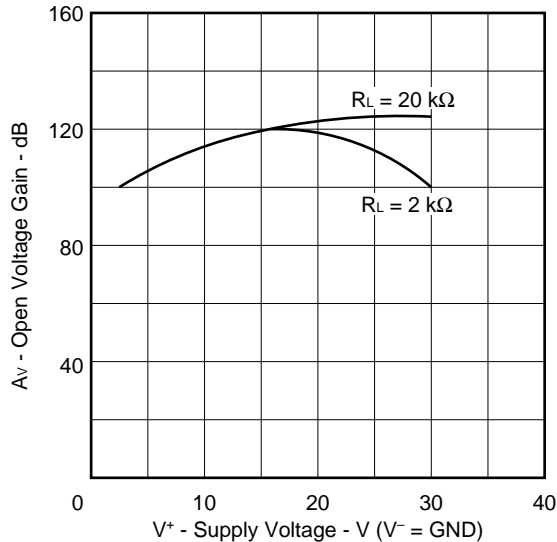

LARGE SIGNAL FREQUENCY RESPONSE

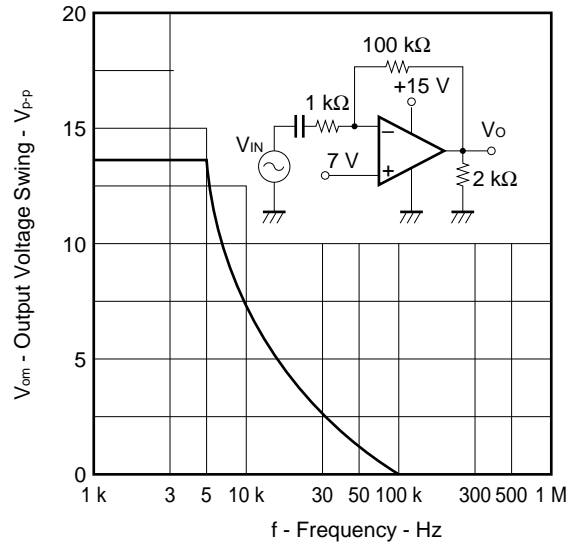

COMMON MODE REJECTION RATIO

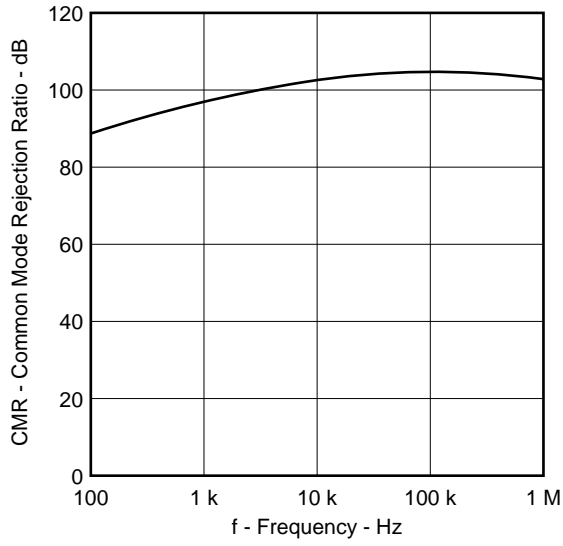

VOLTAGE FOLLOWER PULSE RESPONSE

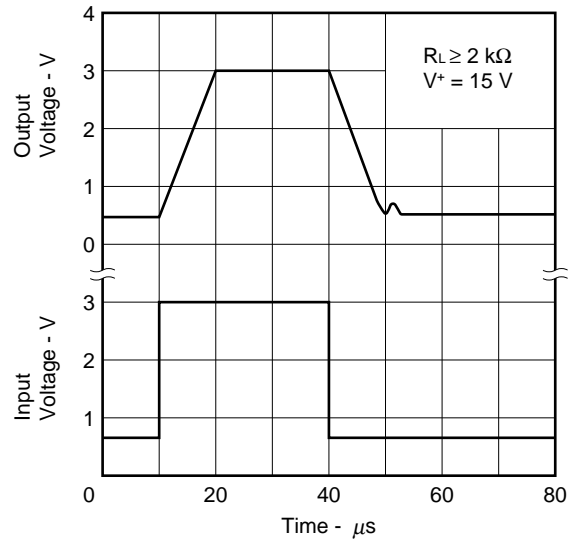

★ SLEW RATE

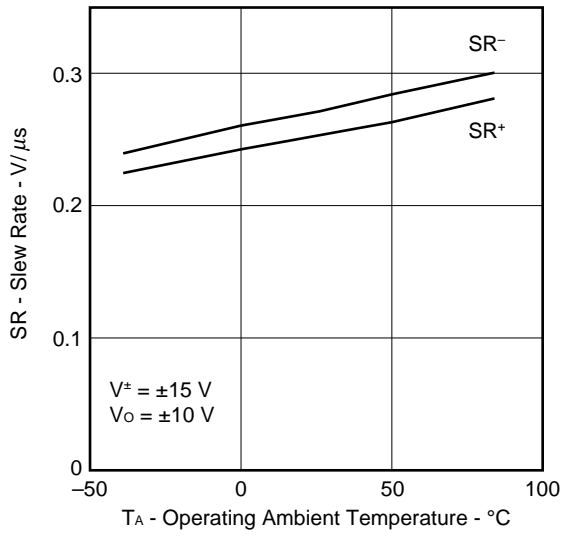

PACKAGE DRAWINGS

14PIN PLASTIC DIP (300 mil)

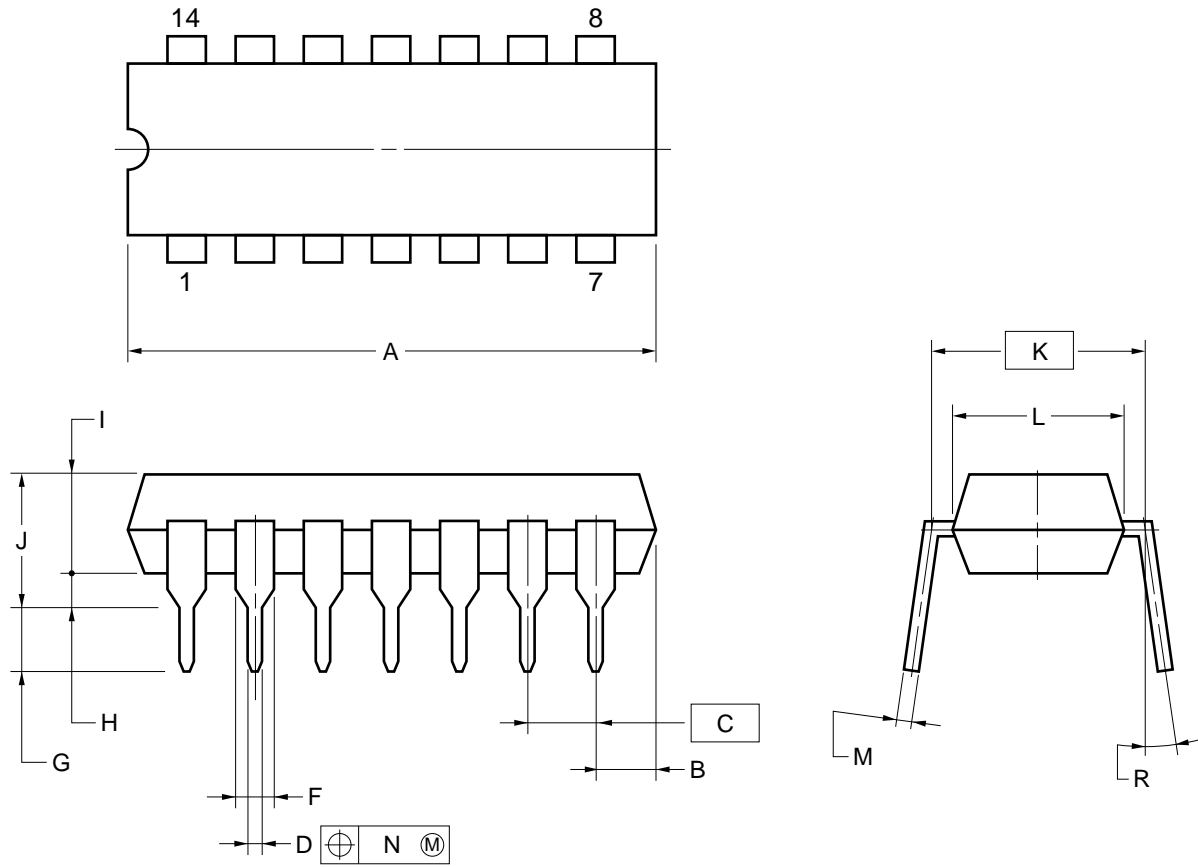

NOTES

- 1) Each lead centerline is located within 0.25 mm (0.01 inch) of its true position (T.P.) at maximum material condition.
- 2) Item "K" to center of leads when formed parallel.

ITEM	MILLIMETERS	INCHES
A	20.32 MAX.	0.800 MAX.
B	2.54 MAX.	0.100 MAX.
C	2.54 (T.P.)	0.100 (T.P.)
D	0.50±0.10	0.020 ^{+0.004} _{-0.005}
F	1.2 MIN.	0.047 MIN.
G	3.6±0.3	0.142±0.012
H	0.51 MIN.	0.020 MIN.
I	4.31 MAX.	0.170 MAX.
J	5.08 MAX.	0.200 MAX.
K	7.62 (T.P.)	0.300 (T.P.)
L	6.4	0.252
M	0.25 ^{+0.10} _{-0.05}	0.010 ^{+0.004} _{-0.003}
N	0.25	0.01
R	0~15°	0~15°

P14C-100-300B1-1

14 PIN PLASTIC SOP (225 mil)

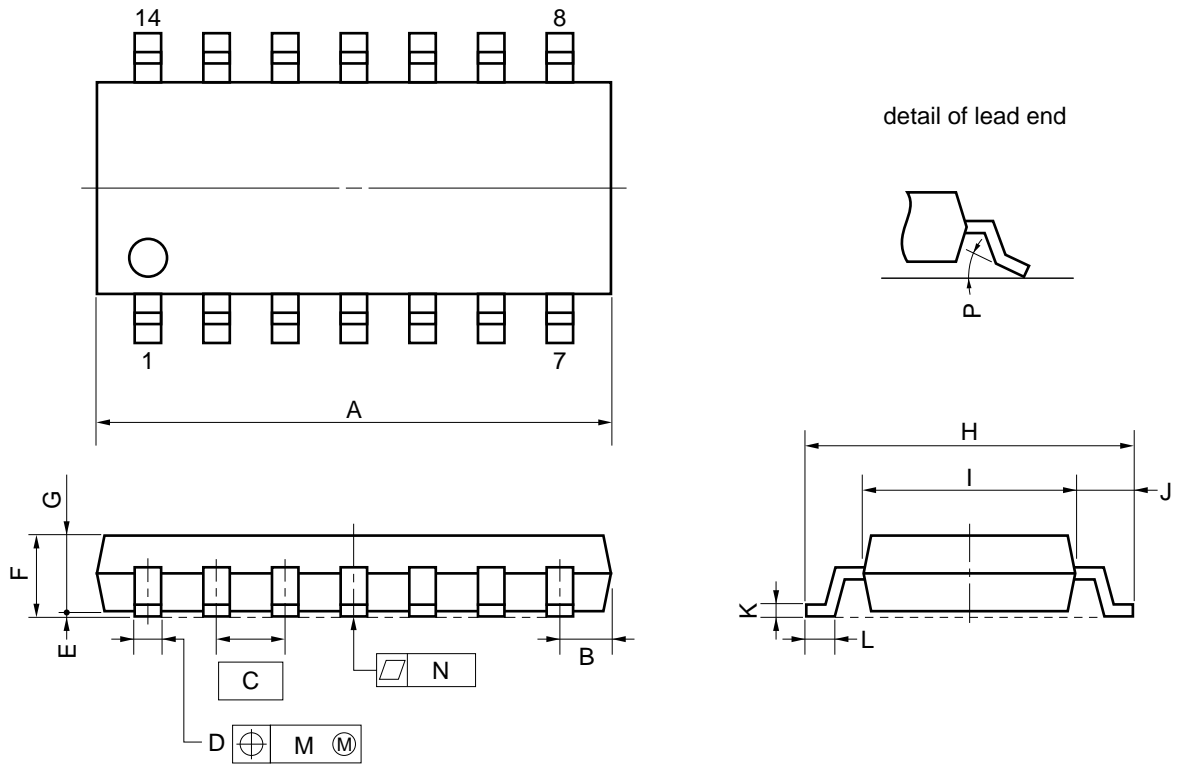

NOTE

Each lead centerline is located within 0.12 mm (0.005 inch) of its true position (T.P.) at maximum material condition.

ITEM	MILLIMETERS	INCHES
A	10.46 MAX.	0.412 MAX.
B	1.42 MAX.	0.056 MAX.
C	1.27 (T.P.)	0.050 (T.P.)
D	0.40 ^{+0.10} _{-0.05}	0.016 ^{+0.004} _{-0.003}
E	0.1±0.1	0.004±0.004
F	1.8 MAX.	0.071 MAX.
G	1.49	0.059
H	6.5±0.3	0.256±0.012
I	4.4	0.173
J	1.1	0.043
K	0.15 ^{+0.10} _{-0.05}	0.006 ^{+0.004} _{-0.002}
L	0.6±0.2	0.024 ^{+0.008} _{-0.009}
M	0.12	0.005
N	0.10	0.004
P	3° ^{+7°} _{-3°}	3° ^{+7°} _{-3°}

S14GM-50-225B, C-4

RECOMMENDED SOLDERING CONDITIONS

When soldering this product, it is highly recommended to observe the conditions as shown below. If other soldering processes are used, or if the soldering is performed under different conditions, please make sure to consult with our sales offices.

For more details, refer to our document “**SEMICONDUCTOR DEVICE MOUNTING TECHNOLOGY MANUAL**” (C10535E).

Surface mount device

μPC324G2: 14-pin plastic SOP (225 mil)

Process	Conditions	Symbol
Infrared ray reflow	Peak temperature: 230 °C or below (Package surface temperature), Reflow time: 30 seconds or less (at 210 °C or higher), Maximum number of reflow processes: 1 time.	IR30-00-1
Vapor Phase Soldering	Peak temperature: 215 °C or below (Package surface temperature), Reflow time: 40 seconds or less (at 200 °C or higher), Maximum number of reflow processes: 1 time.	VP15-00-1
Wave Soldering	Solder temperature: 260 °C or below, Flow time: 10 seconds or less, Maximum number of flow processes: 1 time, Pre-heating temperature: 120 °C or below (Package surface temperature).	WS60-00-1
Partial heating method	Pin temperature: 300 °C or below, Heat time: 3 seconds or less (Per each side of the device).	—

Caution Apply only one kind of soldering condition to a device, except for “partial heating method”, or the device will be damaged by heat stress.

Through-hole device

μPC324C: 14-pin plastic DIP (300 mil)

Process	Conditions
Wave soldering (only to leads)	Solder temperature: 260 °C or below, Flow time: 10 seconds or less.
★ Partial heating method	Pin temperature: 300 °C or below, Heat time: 3 seconds or less (per each lead.)

Caution For through-hole device, the wave soldering process must be applied only to leads, and make sure that the package body does not get jet soldered.

REFERENCE DOCUMENTS

QUALITY GRADES ON NEC SEMICONDUCTOR DEVICES	C11531E
SEMICONDUCTOR DEVICE MOUNTING TECHNOLOGY MANUAL	C10535E
IC PACKAGE MANUAL	C10943X
GUIDE TO QUALITY ASSUARANCE FOR SEMICONDUCTOR DEVICES	MEI-1202
SEMICONDUCTORS SELECTION GUIDE	X10679E
NEC SEMICONDUCTOR DEVICE RELIABILITY/	IEI-1212
QUALITY CONTROL SYSTEM - STANDARD LINEAR IC	

[MEMO]

[MEMO]

[MEMO]

No part of this document may be copied or reproduced in any form or by any means without the prior written consent of NEC Corporation. NEC Corporation assumes no responsibility for any errors which may appear in this document.

NEC Corporation does not assume any liability for infringement of patents, copyrights or other intellectual property rights of third parties by or arising from use of a device described herein or any other liability arising from use of such device. No license, either express, implied or otherwise, is granted under any patents, copyrights or other intellectual property rights of NEC Corporation or others.

While NEC Corporation has been making continuous effort to enhance the reliability of its semiconductor devices, the possibility of defects cannot be eliminated entirely. To minimize risks of damage or injury to persons or property arising from a defect in an NEC semiconductor device, customers must incorporate sufficient safety measures in its design, such as redundancy, fire-containment, and anti-failure features.

NEC devices are classified into the following three quality grades:

"Standard", "Special", and "Specific". The Specific quality grade applies only to devices developed based on a customer designated "quality assurance program" for a specific application. The recommended applications of a device depend on its quality grade, as indicated below. Customers must check the quality grade of each device before using it in a particular application.

Standard: Computers, office equipment, communications equipment, test and measurement equipment, audio and visual equipment, home electronic appliances, machine tools, personal electronic equipment and industrial robots

Special: Transportation equipment (automobiles, trains, ships, etc.), traffic control systems, anti-disaster systems, anti-crime systems, safety equipment and medical equipment (not specifically designed for life support)

Specific: Aircrafts, aerospace equipment, submersible repeaters, nuclear reactor control systems, life support systems or medical equipment for life support, etc.

The quality grade of NEC devices is "Standard" unless otherwise specified in NEC's Data Sheets or Data Books. If customers intend to use NEC devices for applications other than those specified for Standard quality grade, they should contact an NEC sales representative in advance.

Anti-radioactive design is not implemented in this product.