

32K x 8 LOW POWER CMOS STATIC RAM

MARCH 2006

FEATURES

- Access time: 25 ns, 45 ns
- Low active power: 200 mW (typical)
- Low standby power
 - 150 μ W (typical) CMOS standby
 - 15 mW (typical) operating
- Fully static operation: no clock or refresh required
- TTL compatible inputs and outputs
- Single 5V power supply
- Lead-free available
- Industrial and Automotive temperatures available

DESCRIPTION

The *ISSI* IS62C256AL/IS65C256AL is a low power, 32,768 word by 8-bit CMOS static RAM. It is fabricated using *ISSI*'s high-performance, low power CMOS technology.

When \overline{CE} is HIGH (deselected), the device assumes a standby mode at which the power dissipation can be reduced down to 150 μ W (typical) at CMOS input levels.

Easy memory expansion is provided by using an active LOW Chip Select (\overline{CE}) input and an active LOW Output Enable (\overline{OE}) input. The active LOW Write Enable (\overline{WE}) controls both writing and reading of the memory.

The IS62C256AL/IS65C256AL is pin compatible with other 32Kx8 SRAMs in plastic SOP or TSOP (Type I) package.

FUNCTIONAL BLOCK DIAGRAM

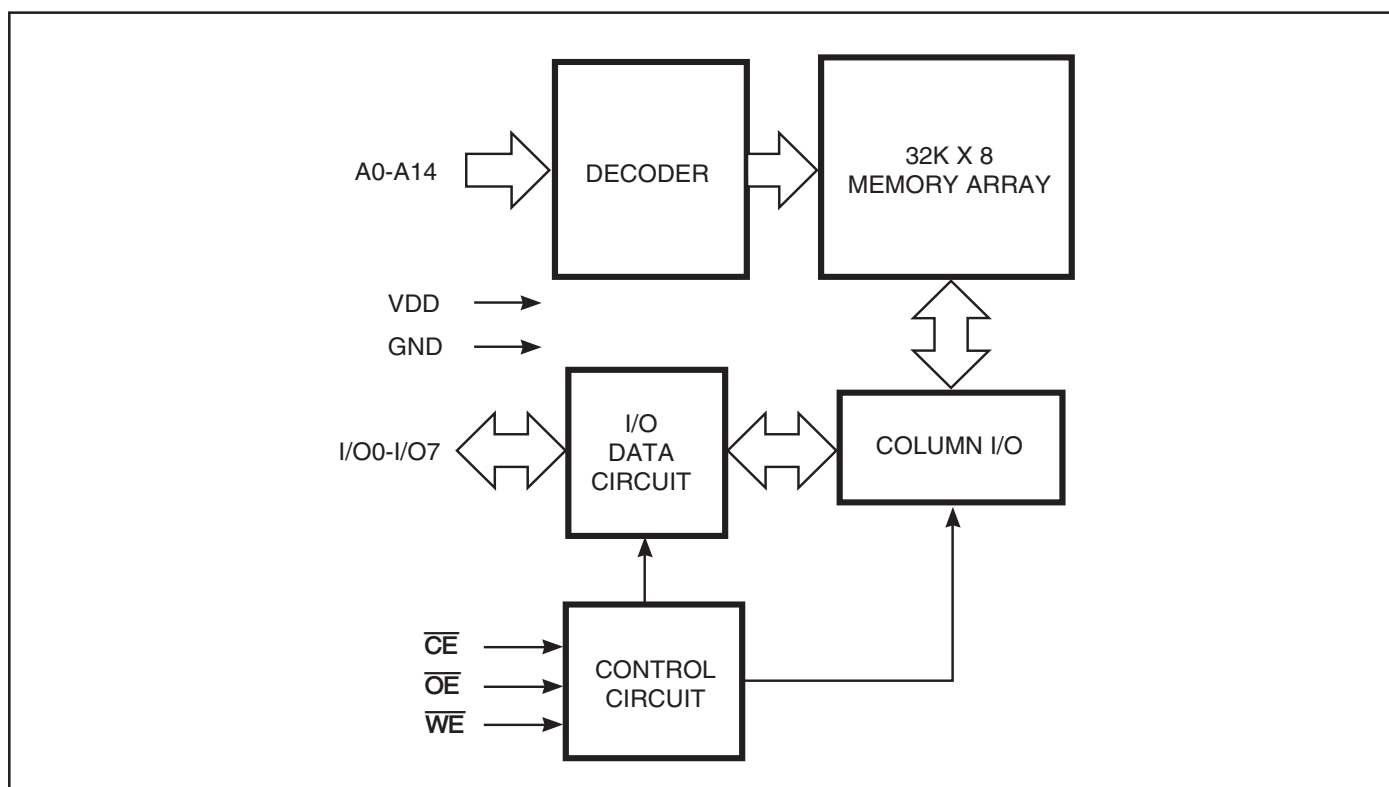

Copyright ©2006 Integrated Silicon Solution, Inc. All rights reserved. ISSI reserves the right to make changes to this specification and its products at any time without notice. ISSI assumes no liability arising out of the application or use of any information, products or services described herein. Customers are advised to obtain the latest version of this device specification before relying on any published information and before placing orders for products.

PIN CONFIGURATION
28-Pin SOP

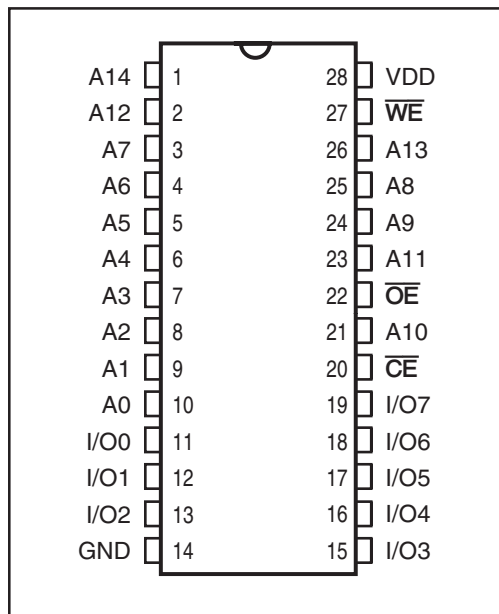

PIN CONFIGURATION
28-Pin TSOP

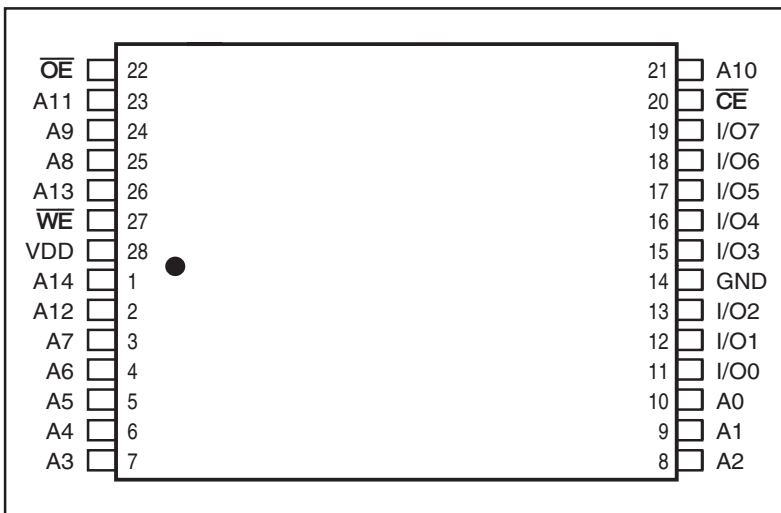

PIN DESCRIPTIONS

A0-A14	Address Inputs
\overline{CE}	Chip Select Input
\overline{OE}	Output Enable Input
\overline{WE}	Write Enable Input
I/O0-I/O7	Input/Output
VDD	Power
GND	Ground

TRUTH TABLE

Mode	\overline{WE}	\overline{CE}	\overline{OE}	I/O Operation	VDD Current
Not Selected (Power-down)	X	H	X	High-Z	ISB1, ISB2
Output Disabled	H	L	H	High-Z	Icc1, Icc2
Read	H	L	L	DOUT	Icc1, Icc2
Write	L	L	X	DIN	Icc1, Icc2

ABSOLUTE MAXIMUM RATINGS⁽¹⁾

Symbol	Parameter	Value	Unit
VTERM	Terminal Voltage with Respect to GND	-0.5 to +7.0	V
TSTG	Storage Temperature	-65 to +150	°C
PT	Power Dissipation	0.5	W
IOUT	DC Output Current (LOW)	20	mA

Note:

1. Stress greater than those listed under ABSOLUTE MAXIMUM RATINGS may cause permanent damage to the device. This is a stress rating only and functional operation of the device at these or any other conditions above those indicated in the operational sections of this specification is not implied. Exposure to absolute maximum rating conditions for extended periods may affect reliability.

OPERATING RANGE

Part No.	Range	Ambient Temperature	V _{DD}
IS62C256AL	Commercial	0°C to +70°C	5V ± 10%
IS62C256AL	Industrial	-40°C to +85°C	5V ± 10%
IS65C256AL	Automotive	-40°C to +125°C	5V ± 10%

DC ELECTRICAL CHARACTERISTICS

Symbol	Parameter	Test Conditions	Min.	Max.	Unit	
V _{OH}	Output HIGH Voltage	V _{DD} = Min., I _{OH} = -1.0 mA	2.4	—	V	
V _{OL}	Output LOW Voltage	V _{DD} = Min., I _{OL} = 2.1 mA	—	0.4	V	
V _{IH}	Input HIGH Voltage		2.2	V _{DD} + 0.5	V	
V _{IL}	Input LOW Voltage ⁽¹⁾		-0.3	0.8	V	
I _{LI}	Input Leakage	GND ≤ V _{IN} ≤ V _{DD}	Com.	-1	1	μA
			Ind.	-2	2	
			Auto.	-10	10	
I _{LO}	Output Leakage	GND ≤ V _{OUT} ≤ V _{DD} , Outputs Disabled	Com.	-1	1	μA
			Ind.	-2	2	
			Auto.	-10	10	

Note: 1. V_{IL} = -3.0V for pulse width less than 10 ns.

POWER SUPPLY CHARACTERISTICS⁽¹⁾ (Over Operating Range)

Symbol	Parameter	Test Conditions		-25 ns		-45 ns		Unit
				Min.	Max.	Min.	Max.	
I _{CC1}	V _{DD} Operating Supply Current	V _{DD} = Max., $\overline{CE} = V_{IL}$ I _{OUT} = 0 mA, f = 0	Com.	—	15	—	15	mA
			Ind.	—	20	—	20	
			Auto.	—	25	—	25	
I _{CC2}	V _{DD} Dynamic Operating Supply Current	V _{DD} = Max., $\overline{CE} = V_{IL}$ I _{OUT} = 0 mA, f = f _{MAX}	Com.	—	25	—	20	mA
			Ind.	—	30	—	25	
			Auto.	—	35	—	30	
			typ. ⁽²⁾	15	12			
I _{SB1}	TTL Standby Current (TTL Inputs)	V _{DD} = Max., V _{IN} = V _{IH} or V _{IL} $\overline{CE} \geq V_{IH}$, f = 0	Com.	—	100	—	100	μA
			Ind.	—	120	—	120	
			Auto.	—	150	—	150	
I _{SB2}	CMOS Standby Current (CMOS Inputs)	V _{DD} = Max., $\overline{CE} \geq V_{DD} - 0.2V$, V _{IN} ≥ V _{DD} - 0.2V, or V _{IN} ≤ 0.2V, f = 0	Com.	—	15	—	15	μA
			Ind.	—	20	—	20	
			Auto.	—	50	—	50	
			typ. ⁽²⁾	5	5			

Note:

- At f = f_{MAX}, address and data inputs are cycling at the maximum frequency, f = 0 means no input lines change.
- Typical values are measured at V_{DD} = 5.0V, T_A = 25°C and not 100% tested.

CAPACITANCE^(1,2)

Symbol	Parameter	Conditions	Max.	Unit
C _{IN}	Input Capacitance	V _{IN} = 0V	8	pF
C _{OUT}	Output Capacitance	V _{OUT} = 0V	10	pF

Notes:

- Tested initially and after any design or process changes that may affect these parameters.
- Test conditions: T_A = 25°C, f = 1 MHz, V_{DD} = 5.0V.

READ CYCLE SWITCHING CHARACTERISTICS⁽¹⁾ (Over Operating Range)

Symbol	Parameter	-25 ns		-45 ns		Unit
		Min.	Max.	Min.	Max.	
t _{RC}	Read Cycle Time	25	—	45	—	ns
t _{AA}	Address Access Time	—	25	—	45	ns
t _{OHA}	Output Hold Time	2	—	2	—	ns
t _{ACS}	\overline{CE} Access Time	—	25	—	45	ns
t _{DOE}	\overline{OE} Access Time	—	13	—	25	ns
t _{LZOE⁽²⁾}	\overline{OE} to Low-Z Output	0	—	0	—	ns
t _{HZOE⁽²⁾}	\overline{OE} to High-Z Output	0	12	0	20	ns
t _{LZCS⁽²⁾}	\overline{CE} to Low-Z Output	3	—	3	—	ns
t _{HZCS⁽²⁾}	\overline{CE} to High-Z Output	0	12	0	20	ns
t _{PU⁽³⁾}	\overline{CE} to Power-Up	0	—	0	—	ns
t _{PD⁽³⁾}	\overline{CE} to Power-Down	—	20	—	30	ns

Notes:

1. Test conditions assume signal transition times of 5 ns or less, timing reference levels of 1.5V, input pulse levels of 0 to 3.0V and output loading specified in Figure 1.
2. Tested with the load in Figure 2. Transition is measured ± 500 mV from steady-state voltage. Not 100% tested.
3. Not 100% tested.

AC TEST CONDITIONS

Parameter	Unit
Input Pulse Level	0V to 3.0V
Input Rise and Fall Times	3 ns
Input and Output Timing and Reference Levels	1.5V
Output Load	See Figures 1 and 2

AC TEST LOADS

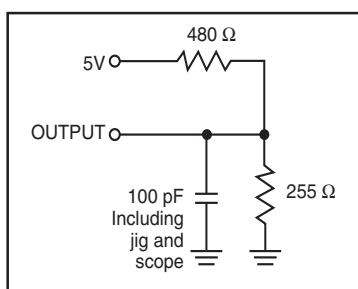

Figure 1.

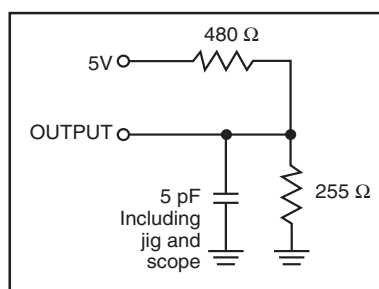
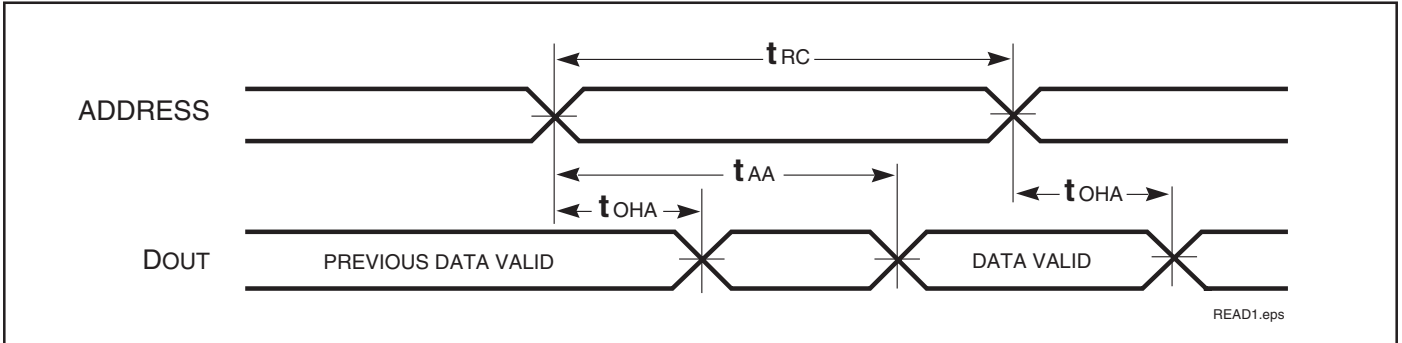

Figure 2.

AC WAVEFORMS

READ CYCLE NO. 1^(1,2)



READ CYCLE NO. 2^(1,3)

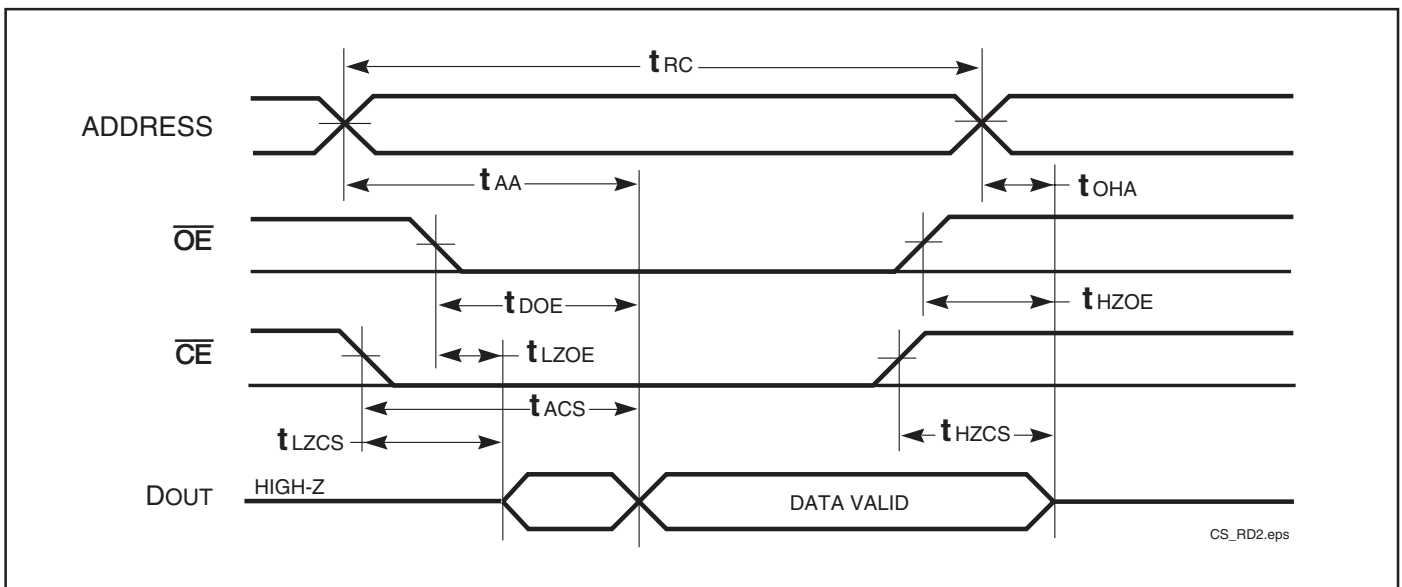

Notes:

1. \overline{WE} is HIGH for a Read Cycle.
2. The device is continuously selected. \overline{OE} , \overline{CE} = V_{IL}.
3. Address is valid prior to or coincident with \overline{CE} LOW transitions.

WRITE CYCLE SWITCHING CHARACTERISTICS^(1,3) (Over Operating Range)

Symbol	Parameter	-25 ns		-45 ns		Unit
		Min.	Max.	Min.	Max.	
t _{wc}	Write Cycle Time	25	—	45	—	ns
t _{sCS}	\overline{CE} to Write End	15	—	35	—	ns
t _{AW}	Address Setup Time to Write End	15	—	25	—	ns
t _{HA}	Address Hold from Write End	0	—	0	—	ns
t _{SA}	Address Setup Time	0	—	0	—	ns
t _{PWE1} , t _{PWE2} ⁽⁴⁾	\overline{WE} Pulse Width	15	—	25	—	ns
t _{SD}	Data Setup to Write End	12	—	20	—	ns
t _{HD}	Data Hold from Write End	0	—	0	—	ns

Notes:

1. Test conditions assume signal transition times of 5 ns or less, timing reference levels of 1.5V, input pulse levels of 0 to 3.0V and output loading specified in Figure 1.
2. Tested with the load in Figure 2. Transition is measured ± 500 mV from steady-state voltage. Not 100% tested.
3. The internal write time is defined by the overlap of \overline{CE} LOW and \overline{WE} LOW. All signals must be in valid states to initiate a Write, but any one can go inactive to terminate the Write. The Data Input Setup and Hold timing are referenced to the rising or falling edge of the signal that terminates the write.
4. Tested with \overline{OE} HIGH.

AC WAVEFORMS

WRITE CYCLE NO. 1 (\overline{CE} Controlled, \overline{OE} is HIGH or LOW) ⁽¹⁾

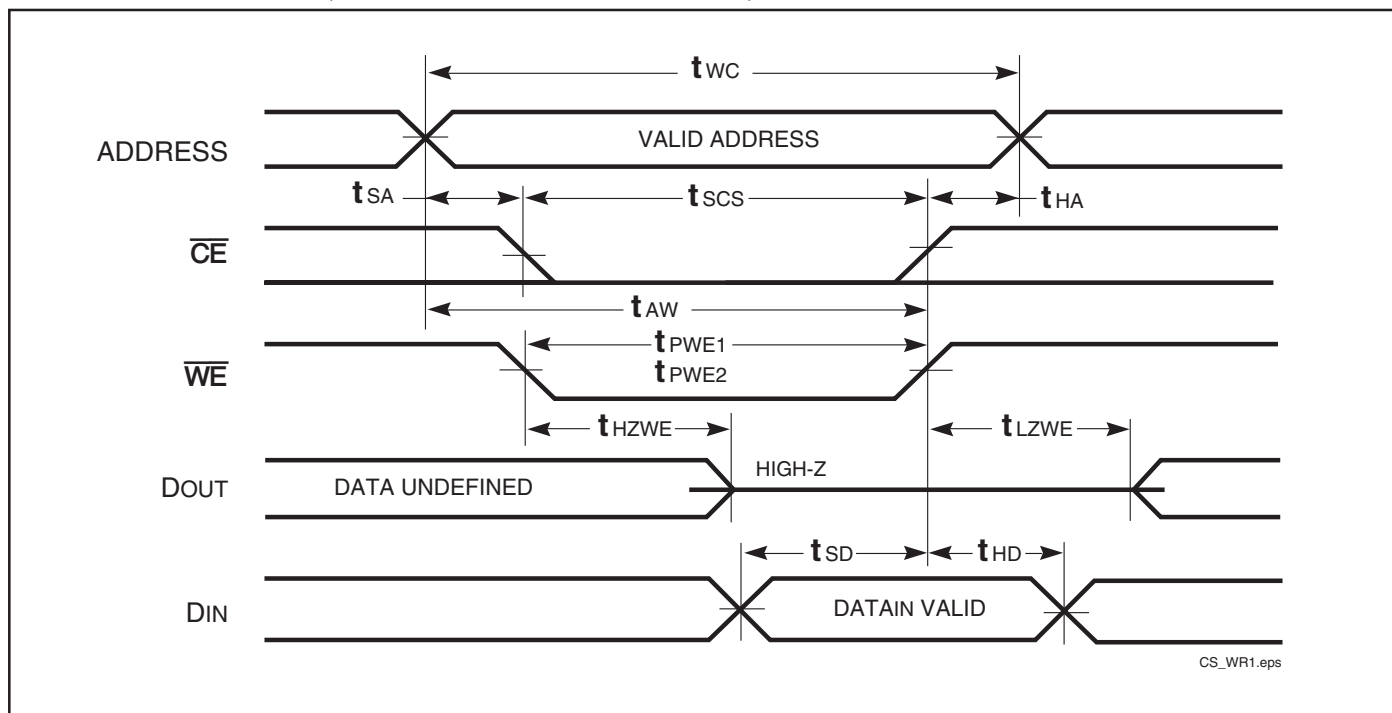

AC WAVEFORMS

WRITE CYCLE NO. 2 (\overline{OE} is HIGH During Write Cycle) ^(1,2)

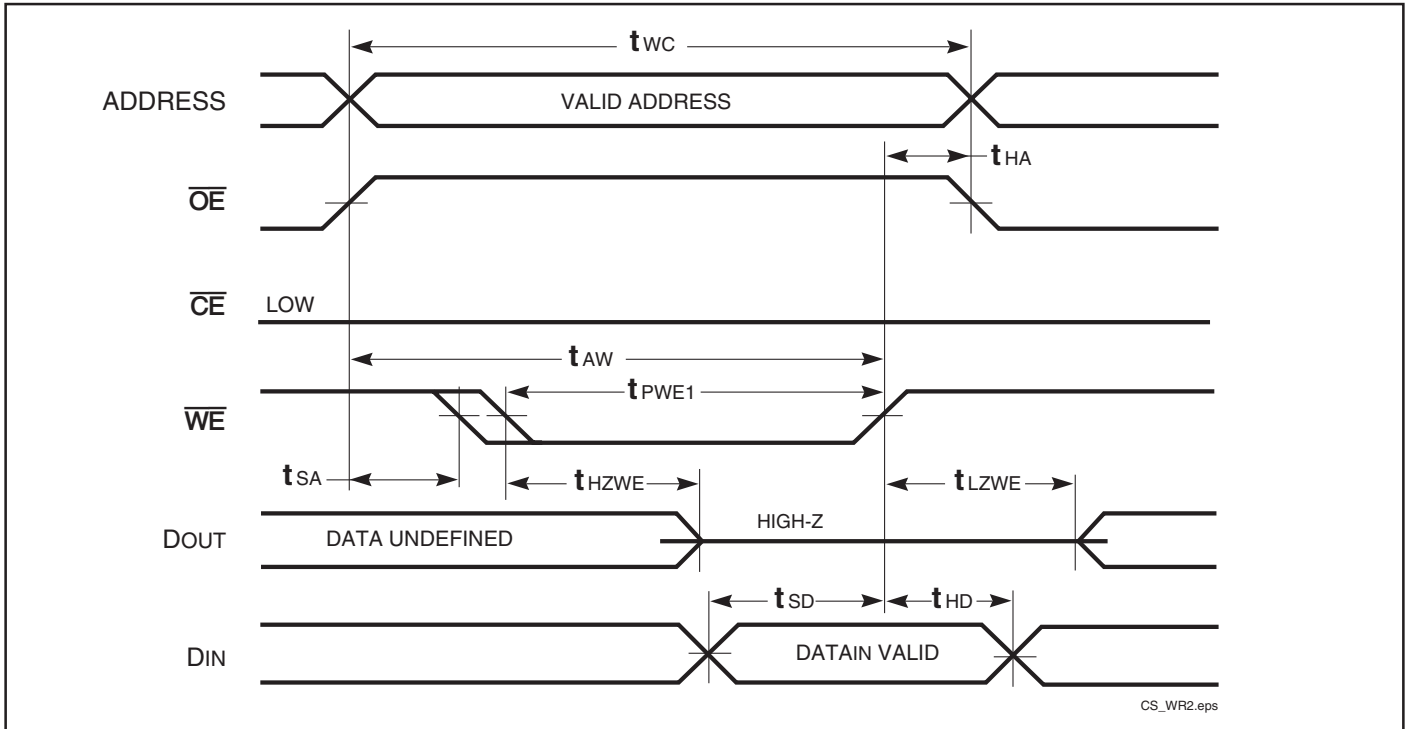

WRITE CYCLE NO. 3 (\overline{OE} is LOW During Write Cycle) ⁽¹⁾

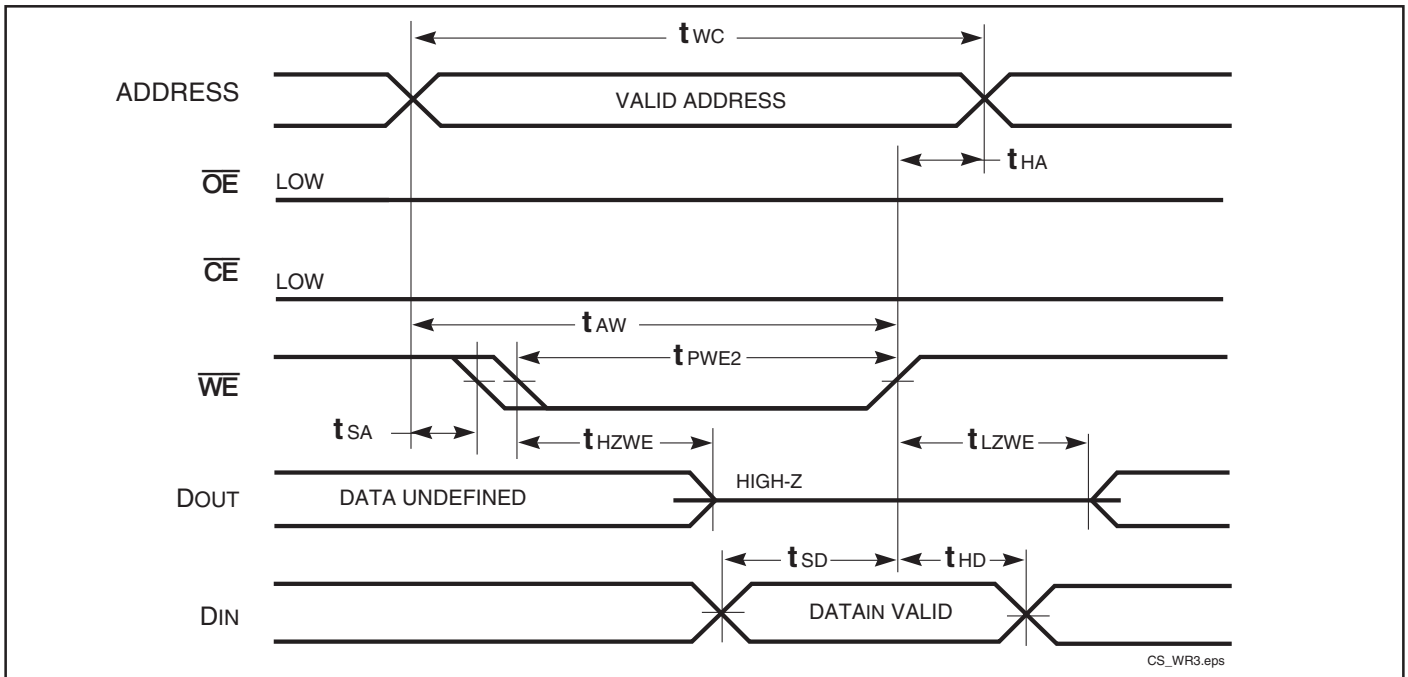

Notes:

1. The internal write time is defined by the overlap of \overline{CE} LOW and \overline{WE} LOW. All signals must be in valid states to initiate a Write, but any one can go inactive to terminate the Write. The Data Input Setup and Hold timing are referenced to the rising or falling edge of the signal that terminates the write.
2. I/O will assume the High-Z state if $\overline{OE} = V_{IH}$.

DATA RETENTION SWITCHING CHARACTERISTICS

Symbol	Parameter	Test Condition	Min.	Typ.	Max.	Unit
V _{DR}	V _{DD} for Data Retention	See Data Retention Waveform	2.0		5.5	V
I _{DR}	Data Retention Current	V _{DD} = 2.0V, $\overline{CE} \geq V_{DD} - 0.2V$ V _{IN} ≥ V _{DD} - 0.2V, or V _{IN} ≤ V _{SS} + 0.2V	—	—	15	μA
			—	—	20	
			—	—	50	
t _{SDR}	Data Retention Setup Time	See Data Retention Waveform	0		—	ns
t _{RDR}	Recovery Time	See Data Retention Waveform	t _{RC}		—	ns

Note:

1. Typical Values are measured at V_{DD} = 5V, T_A = 25°C and not 100% tested.

DATA RETENTION WAVEFORM (\overline{CE} Controlled)

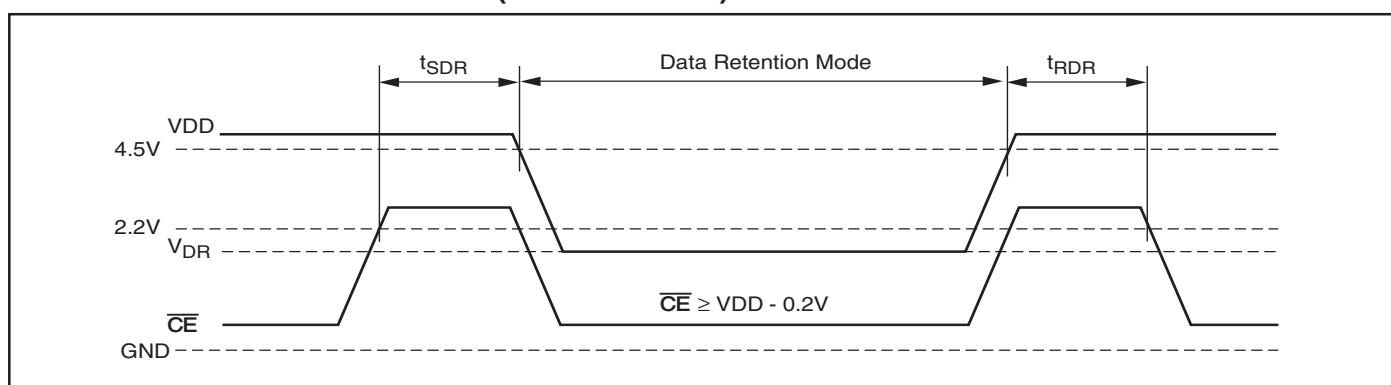

ORDERING INFORMATION

Commercial Range: 0°C to +70°C

Speed (ns)	Order Part No.	Package
45	IS62C256AL-45T	TSOP
	IS62C256AL-45TL	TSOP, Lead-free
	IS62C256AL-45U	Plastic SOP
	IS62C256AL-45UL	Plastic SOP, Lead-free

ORDERING INFORMATION

Industrial Range: -40°C to +85°C

Speed (ns)	Order Part No.	Package
25	IS62C256AL-25TI	TSOP
	IS62C256AL-25UI	Plastic SOP
45	IS62C256AL-45TI	TSOP
	IS62C256AL-45TLI	TSOP, Lead-free
	IS62C256AL-45UI	Plastic SOP
	IS62C256AL-45ULI	Plastic SOP, Lead-free

ORDERING INFORMATION

Automotive Range: -40°C to +125°C

Speed (ns)	Order Part No.	Package
25	IS65C256AL-25TA3	TSOP
	IS65C256AL-25TLA3	TSOP, Lead-free
	IS65C256AL-25UA3	Plastic SOP
	IS65C256AL-25ULA3	Plastic SOP, Lead-free
45	IS65C256AL-45TA3	TSOP
	IS65C256AL-45TLA3	TSOP, Lead-free
	IS65C256AL-45UA3	Plastic SOP
	IS65C256AL-45ULA3	Plastic SOP, Lead-free

PACKAGING INFORMATION



Plastic TSOP - 28-pins
 Package Code: T (Type I)

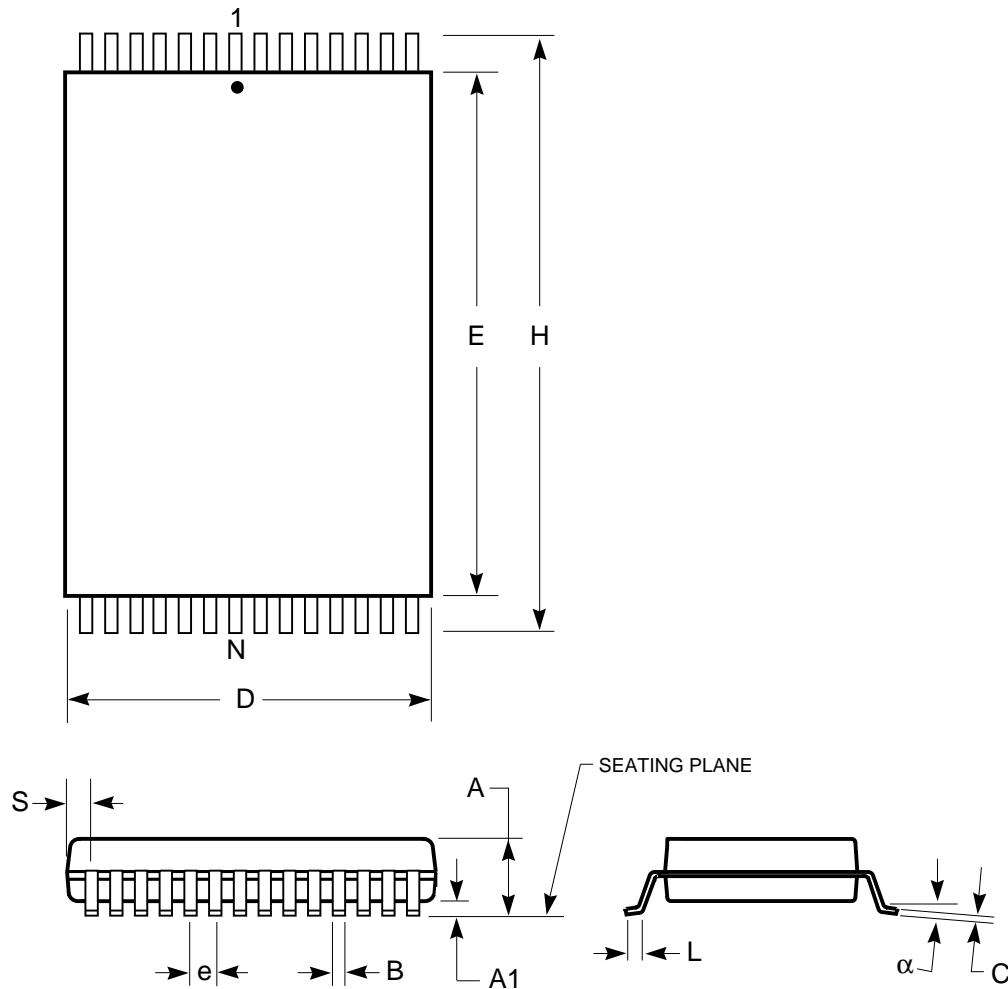

Plastic TSOP (T—Type I)				
Symbol	Millimeters		Inches	
	Min	Max	Min	Max
Ref. Std.				
No. Leads	28			
A	1.00	1.20	0.037	0.047
A1	0.05	0.20	0.002	0.008
B	0.16	0.27	0.006	0.011
C	0.10	0.20	0.004	0.008
D	7.90	8.10	0.308	0.316
E	11.70	11.90	0.456	0.465
H	13.20	13.60	0.515	0.531
e	0.55 BSC		0.022 BSC	
L	0.30	0.70	0.011	0.027
α	0°	5°	0°	5°

Notes:

1. Controlling dimension: millimeters, unless otherwise specified.
2. BSC = Basic lead spacing between centers.
3. Dimensions D and E do not include mold flash protrusions and should be measured from the bottom of the package.
4. Formed leads shall be planar with respect to one another within 0.004 inches at the seating plane.

PACKAGING INFORMATION



330-mil Plastic SOP Package Code: U (28-pin)

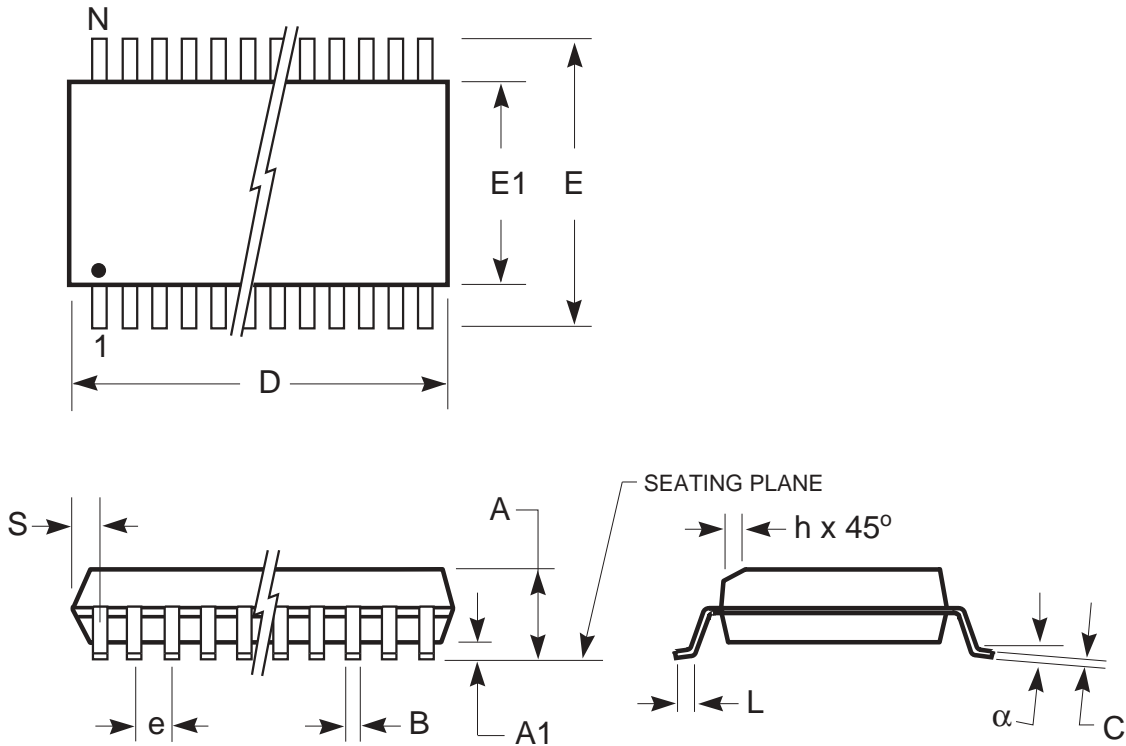

	MILLIMETERS		INCHES	
Sym.	Min.	Max.	Min.	Max.
No. Leads	28		28	
A	—	2.84	—	0.112
A1	0.10	—	0.004	—
B	0.36	0.51	0.014	0.020
C	0.25	—	0.010	—
D	17.98	18.24	0.708	0.718
E	11.51	12.12	0.453	0.477
E1	8.28	8.53	0.326	0.336
e	1.27 BSC		0.050 BSC	
h	0.30	0.51	0.012	0.020
L	0.71	1.14	0.028	0.045
α	0°	8°	0°	8°
S	0.58	1.19	0.023	0.047

Notes:

1. Controlling dimension: inches, unless otherwise specified.
2. BSC = Basic lead spacing between centers.
3. Dimensions D and E1 do not include mold flash protrusions and should be measured from the bottom of the package.
4. Formed leads shall be planar with respect to one another within 0.004 inches at the seating plane.

Copyright © 2003 Integrated Silicon Solution, Inc. All rights reserved. ISSI reserves the right to make changes to this specification and its products at any time without notice. ISSI assumes no liability arising out of the application or use of any information, products or services described herein. Customers are advised to obtain the latest version of this device specification before relying on any published information and before placing orders for products.

Integrated Silicon Solution, Inc. — www.issi.com — 1-800-379-4774

Rev. C
02/26/03