

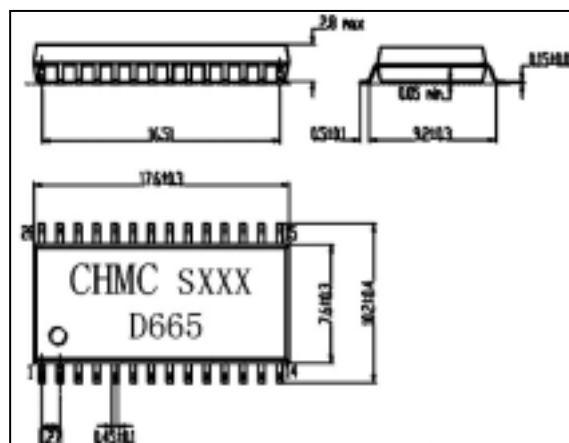

## IC FOR HEADPHONE STEREOS MONOLITHIC IC D665

### GENERAL DESCRIPTION

D665 was developed for use in headphone stereos, and incorporates dual preamp, power amp, electronic VR and motor control circuits. It can be used in a simple circuit configuration which requires very few external components.



Outline drawing

### FEATURES

- Broad operating voltage range of 2.0 to 5.0V (amp system operates to 1.8V)
- Few external components required
  1. Internal equalizer resistance
  2. Direct coupling of preamps, electronic VR, power amp
  3. No need for output coupling capacitor
- Well-balanced electronic VR, A-curve attenuation characteristic obtained with B-curve VR
- Internal motor control circuit, with noise from motor driving unit suppressed
- Provided with pin to turn off preamps
- Package: SOP28

### PIN CONNECTION

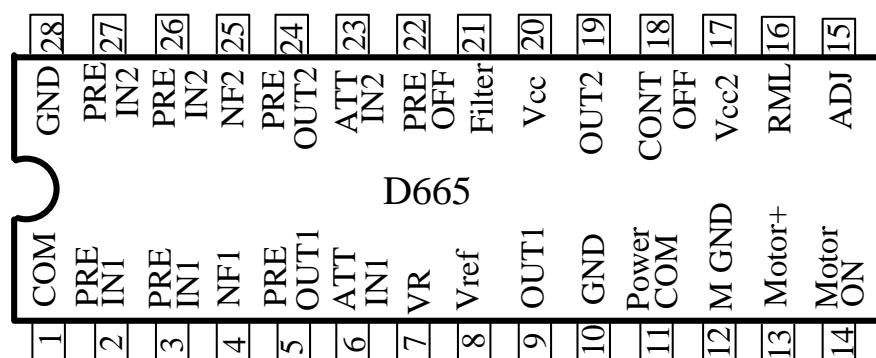

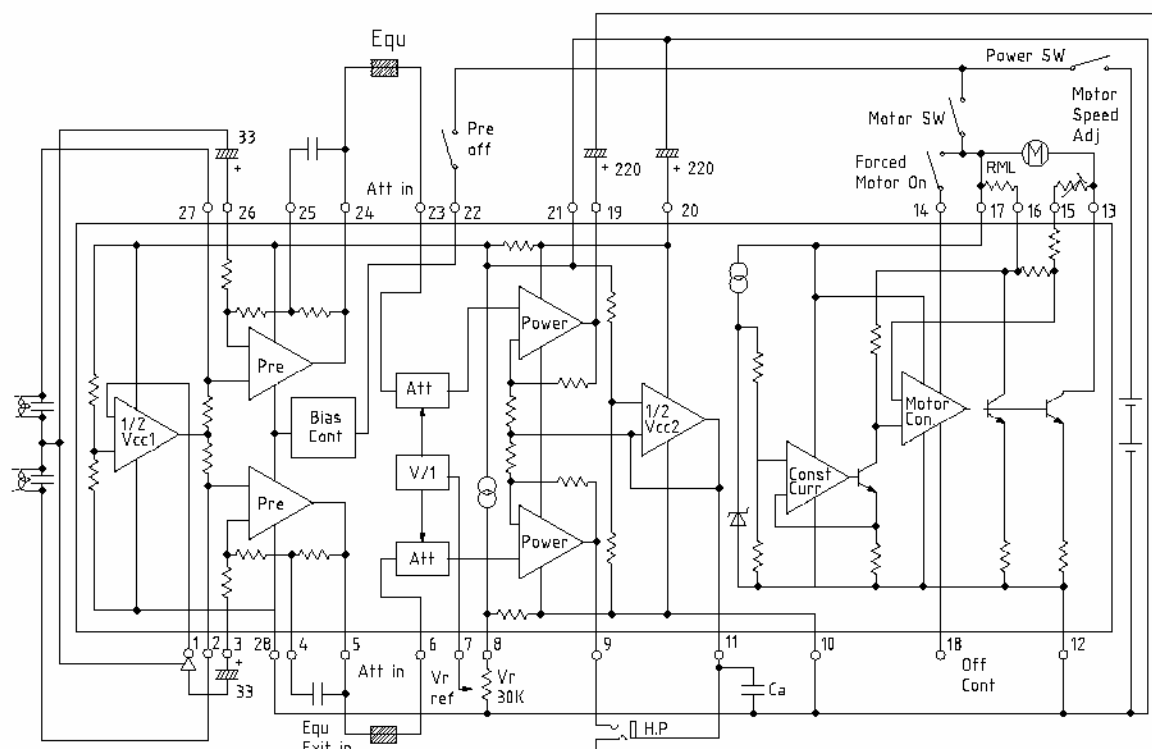
**BLOCK DIAGRAM**

Note 1. The potentiometer for motor speed adjustment is 150HM (where the motor used is assumed to be M25E-7 (Mitsumi)).

Note 2. RML (motor load correction resistance)

Note 3. When the preamp off pin is connected to +Vcc, the preamp circuits are turned off.

Note 4. When the motor forced-on pin is connected to +Vcc, the motor is turned on (no control).

Ca is a 100,000pF capacitor used to prevent oscillation in the 1/2 Vcc and amp circuits. Pin 15 and pin 16 are NC.

**ABSOLUTE MAXIMUM RATINGS**

CHARACTERISTICS	SYMBOL	RATING	UNIT
Operating temperature	Topr	-20~65	°C
Storage temperature	Tstg	-40~125	°C
Power supply current	Vcc max.	-0.3~7.5	V
Power consumption	Pd	450	mW
Operating voltage	Vop	2.0~5.0	V

**ELECTRICAL CHARACTERISTICS** (Except where noted otherwise, Ta=25°)

Characteristics	Symbol	Test Conditions	Min.	Typ.	Max.	UNIT
Consumption current	Icc	Vin=0V, IM=0mA	-	18	25	mA
Preamp. Unit (Ta=25°C)						
Open-circuit gain	Gvo	Vo=-10dBm, RL=	-	72	-	dB
Closed-circuit gain	Gvc	Vo=-10dBm	40	42	44	dB
Maximum output voltage	Vom	THD=10%	0.45	0.6	-	Vrms
Total harmonic distortion ratio	THD	Vout=400mVrms	-	0.05	0.5	%
Output noise voltage	Vno	Vin=0, Rg=2.2k, BPF(30~20kHz)	-	150	300	μVrms
Input impedance	Zin	Vout=-10dBm	18	22	-	kΩ
Cross-talk between channel	C.T	Rg=2.2k, Vout=-10dBm	30	-	-	dB
Output voltage with pre off	Vooff	Vin=100mVrms	-	-	-50	dB
Output resistance with pre off	Rooff	-	-	10	-	kΩ
Input resistance on pre off	Rioff	-	-	10	-	kΩ
Attenuation unit(Ta=25°C)						
Maximum input voltage	Vi max.	-	0.2	-	-	Vrms
Maximum attenuation	Va max.	Vcont=min.	66	-	-	dB
Attenuation error	Vaerr	Vcont=max.	-	0	-	dB
Input impedance	Zin	-	15	20	-	kΩ
Control pin input resistance	Zicot	-	100	-	-	kΩ

**ELECTRICAL CHARACTERISTICS**

continue

Characteristics	Symbol	Test Conditions	Min.	Typ.	Max.	UNIT
Power amp unit (Ta=25°C) Vcc=3.0V,f=1kHz, RL=16Ω,Pre OFF=OPEN						
Voltage gain	Gv	Pout=5mW	26	28	30	dB
Voltage gain difference between channels	Gv	Vcont=max.	-	0	3	dB
Maximum output power 1	Pom1	THD=10%,RL=32Ω	20	28	-	mW
Maximum output power 2	Pom2	THD=10%,RL=16Ω	30		-	mW
Total harmonic distortion ratio	THD	Pout=5mW	-	0.2	2.0	%
Cross-talk between channel	C.T	Pout=5mW	20	30	-	dB
Output noise voltage	Vn	Rg=2.2k, Vcont=min	-	0.25	1.0	mVrms
Ripple rejection	R.R	Vcc=3V, 100Hz, 100mVp-p	34	40	-	dB
Noise of pre amp+power amp	Vnto	Vin=0V,Rg=2.2k, Vcont=max.	-	6	9	mVrms
Motor control unit(Ta=25°C) Vcc=3.0V,Im=100mA, Motor unit : ( Mitsumi model)						
Consumption current	IMC		-	3.0	5.0	mA
Startup current	IMS		500	-	-	mA
Reference voltage	Vref	Between RML-ADJ pins	0.72	0.80	0.87	V
Reference voltage Fluctuation 1	Vref1	Vcc between 2.1 and 5.0V*	-	0.05	-	%/V
Reference voltage Fluctuation 2	Vref2	Im between 25 and 250mA	-	0.01	-	%/mA
Reference voltage Fluctuation 3	Vref3	Ta between -10and 50°C	-	0.01	-	%/°C
Current coefficient	K		32	38	43	
Current coefficient Fluctuation 1	K1	Vcc between 2.1 and 5.0V	-	0.5	-	%/V
Current coefficient Fluctuation 2	K2	Im between 25 and 250mA	-	0.05	-	%/mA
Current coefficient Fluctuation 3	K3	Ta between -10 and 50°C	-	0.02	-	%/°C
Output voltage on forced on	Vce sat	Im=200mA, 14PIN=Vcc	-	-	0.6	V
Input resistance on forced on	Rion		-	5.6	-	kΩ
Leakage current on forced off	IML		-	-	200	μA
Input resistance on forced off	Ricon		-	33	-	kΩ

Note 1: Bass boost circuit constants are based on application circuit diagrams.

Note 2: Motor pin voltage fluctuation.

\* Voltage across pins 13 and 19(motor pins ) fluctuates.

## TEST CIRCUITS

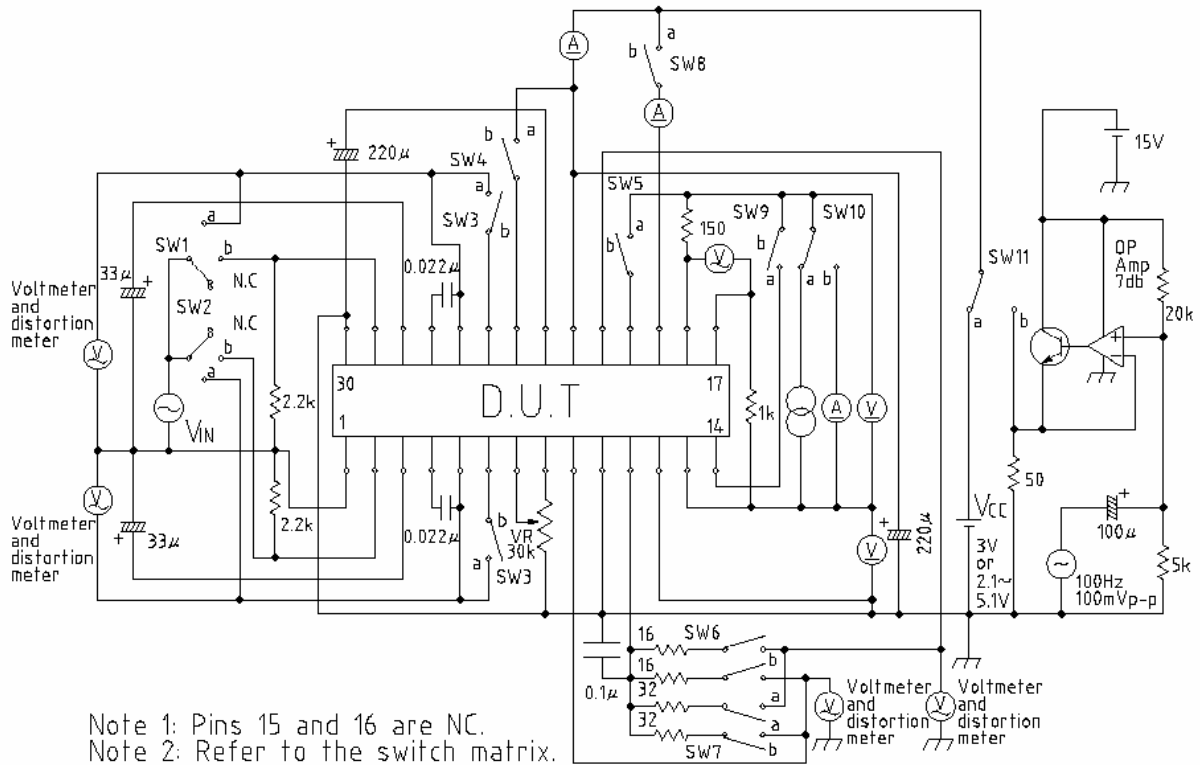

## CHARACTERISTICS CURVES

Preamp

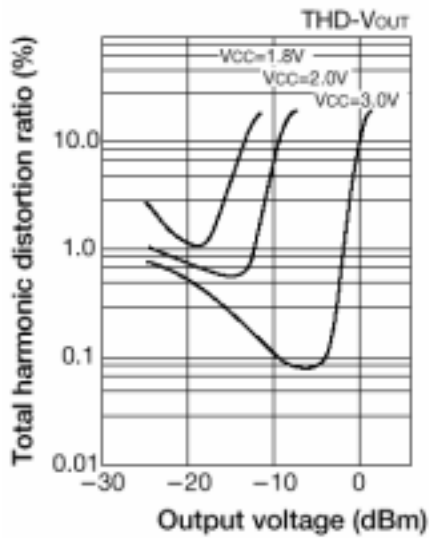

Attenuator

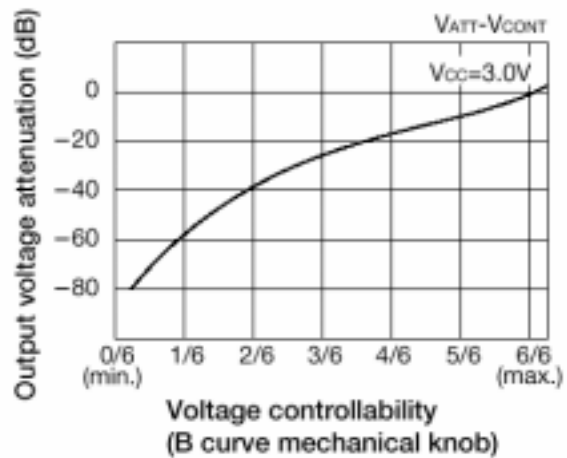

Pout.

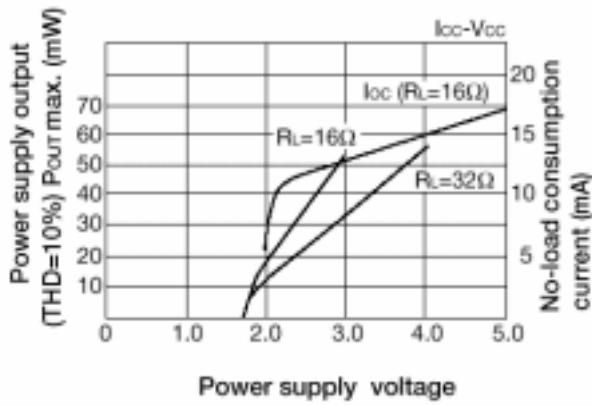

Power amp

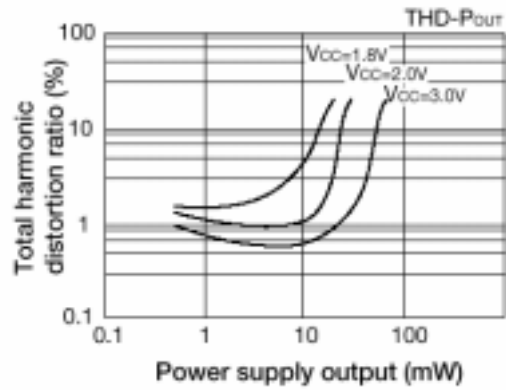

Power amp

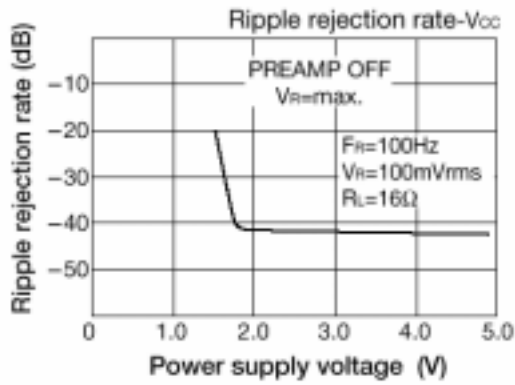

Power amp

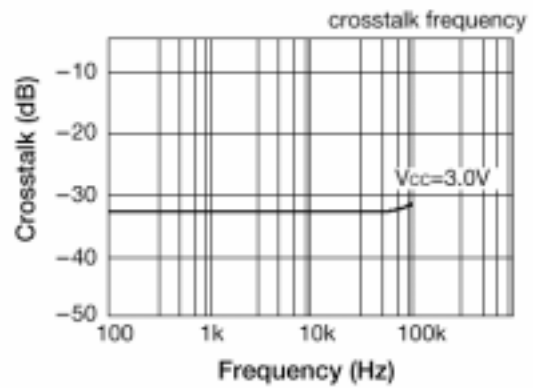

Voltage gain vs. frequency

