

## 3803 Group (Spec.H) SINGLE-CHIP 8-BIT CMOS MICROCOMPUTER

REJ03B0017-0302Z

Rev.3.02

Nov 05, 2004

### 3803 Group (Spec. H) Mask ROM version DESCRIPTION

The 3803 group (Spec. H) is the 8-bit microcomputer based on the 740 family core technology.

The 3803 group (Spec. H) is designed for household products, office automation equipment, and controlling systems that require analog signal processing, including the A-D converter and D-A converters.

### FEATURES

- Basic machine-language instructions ..... 71
- Minimum instruction execution time ..... 0.24 μs  
(at 16.8 MHz oscillation frequency)
- Memory size
  - ROM ..... 16 K to 60 K bytes
  - RAM ..... 640 to 2048 bytes
- Programmable input/output ports ..... 56
- Software pull-up resistors ..... Built-in
- Interrupts
  - 21 sources, 16 vectors .....  
(external 8, internal 12, software 1)
- Timers ..... 16-bit X 1  
8-bit X 4  
(with 8-bit prescaler)
- Watchdog timer ..... 16-bit X 1
- Serial I/O ..... 8-bit X 2 (UART or Clock-synchronized)  
8-bit X 1 (Clock-synchronized)
- PWM ..... 8-bit X 1 (with 8-bit prescaler)
- A-D converter ..... 10-bit X 16 channels  
(8-bit reading enabled)

- D-A converter ..... 8-bit X 2 channels
- LED direct drive port ..... 8
- Clock generating circuit ..... Built-in 2 circuits  
(connect to external ceramic resonator or quartz-crystal oscillator)
- Power source voltage
  - In high-speed mode
    - At 16.8 MHz oscillation frequency ..... 4.5 to 5.5 V
    - At 12.5 MHz oscillation frequency ..... 4.0 to 5.5 V
    - At 8.4 MHz oscillation frequency ..... 2.7 to 5.5 V
    - At 4.2 MHz oscillation frequency ..... 2.2 to 5.5 V
    - At 2.1 MHz oscillation frequency ..... 2.0 to 5.5 V
  - In middle-speed mode
    - At 16.8 MHz oscillation frequency ..... 4.5 to 5.5 V
    - At 12.5 MHz oscillation frequency ..... 2.7 to 5.5 V
    - At 8.4 MHz oscillation frequency ..... 2.2 to 5.5 V
    - At 6.3 MHz oscillation frequency ..... 1.8 to 5.5 V
  - In low-speed mode
    - At 32 kHz oscillation frequency ..... 1.8 to 5.5 V
- Power dissipation
  - In high-speed mode ..... 40 mW (typ.)  
(at 16.8 MHz oscillation frequency, at 5 V power source voltage)
  - In low-speed mode ..... 45 μW (typ.)  
(at 32 kHz oscillation frequency, at 3 V power source voltage)
- Operating temperature range ..... -20 to 85°C
- Packages
  - SP ..... 64P4B (64-pin 750 mil SDIP)
  - FP ..... 64P6N-A (64-pin 14 X 14 mm QFP)
  - HP ..... 64P6Q-A (64-pin 10 X 10 mm LQFP)
  - KP ..... 64P6U-A (64-pin 14 X 14 mm LQFP)
  - WG ..... 64F0G (64-pin 6 X 6 mm FLGA)

Currently support products are listed below.

**Table 1 Support products (Mask ROM version)**

Product name	ROM size (bytes) ROM size for User in ( )	RAM size (bytes)	Package	Remarks
M38034M4H-XXXSP	16384 (16254)	640	64P4B	
M38034M4H-XXXFP			64P6N-A	
M38034M4H-XXXHP			64P6Q-A	
M38034M4H-XXXKP			64P6U-A	
M38037M6H-XXXSP	24576 (24446)	1024	64P4B	
M38037M6H-XXXFP			64P6N-A	
M38037M6H-XXXHP			64P6Q-A	
M38037M6H-XXXKP			64P6U-A	
M38037M8H-XXXSP	32768 (32638)	1024	64P4B	
M38037M8H-XXXFP			64P6N-A	
M38037M8H-XXXHP			64P6Q-A	
M38037M8H-XXXKP			64P6U-A	
M38037M8H-XXXWG			64F0G	
M38039MCH-XXXSP	49152 (49022)	2048	64P4B	
M38039MCH-XXXFP			64P6N-A	
M38039MCH-XXXHP			64P6Q-A	
M38039MCH-XXXKP			64P6U-A	
M38039MFH-XXXSP	61440 (61310)	2048	64P4B	
M38039MFH-XXXFP			64P6N-A	
M38039MFH-XXXHP			64P6Q-A	
M38039MFH-XXXKP			64P6U-A	
M38039MFH-XXXWG			64F0G	

**Note:** Electrical characteristics differ by the 3803 group standard versions and the 3803 group (spec. H). Since the 3803 group standard versions are not indicated to this data sheet, refer to "3803/3804 Group Data Sheet".

3803 Group (Spec. H) Flash memory version

**3803 Group (Spec. H) Flash memory version DESCRIPTION**

The 3803 group (Spec. H) flash memory version is the 8-bit micro-computer based on the 740 family core technology.

The 3803 group (Spec. H) is designed for household products, office automation equipment, and controlling systems that require analog signal processing, including the A-D converter and D-A converters.

**FEATURES**

- Basic machine-language instructions ..... 71
- Minimum instruction execution time ..... 0.24 μs  
(at 16.8 MHz oscillation frequency)
- Memory size  
Flash memory ..... 60 K bytes  
RAM ..... 2048 bytes
- Programmable input/output ports ..... 56
- Software pull-up resistors ..... Built-in
- Interrupts  
21 sources, 16 vectors .....  
(external 8, internal 12, software 1)
- Timers ..... 16-bit X 1  
8-bit X 4  
(with 8-bit prescaler)
- Watchdog timer ..... 16-bit X 1
- Serial I/O ..... 8-bit X 2 (UART or Clock-synchronized)  
8-bit X 1 (Clock-synchronized)
- PWM ..... 8-bit X 1 (with 8-bit prescaler)
- A-D converter ..... 10-bit X 16 channels  
(8-bit reading enabled)
- D-A converter ..... 8-bit X 2 channels
- LED direct drive port ..... 8
- Clock generating circuit ..... Built-in 2 circuits  
(connect to external ceramic resonator or quartz-crystal oscillator)

Currently support products are listed below.

**Table 2 Support products (Flash memory version)**

Product name	Flash memory size (bytes)	RAM size (bytes)	Package	Remarks
M38039FFHSP	61440	2048	64P4B	Vcc = 2.7 to 5.5 V Under development
M38039FFHFP			64P6N-A	
M38039FFHHP			64P6Q-A	
M38039FFHKP			64P6U-A	
M38039FFHWG			64F0G	
M38039FFSP			64P4B	Vcc = 4.0 to 5.5 V
M38039FFFP			64P6N-A	
M38039FFHP			64P6Q-A	

**Note:** Since description, features, and electrical characteristics etc. of M38039FFSP, M38039FFFP, M38039FFHP are not indicated, refer to "3803/3804 group Data Sheet".

- Power source voltage  
In high-speed mode  
At 16.8 MHz oscillation frequency ..... 4.5 to 5.5 V  
At 12.5 MHz oscillation frequency ..... 4.0 to 5.5 V  
At 8.4 MHz oscillation frequency) ..... 2.7 to 5.5 V  
In middle-speed mode  
At 16.8 MHz oscillation frequency ..... 4.5 to 5.5 V  
At 12.5 MHz oscillation frequency ..... 2.7 to 5.5 V  
In low-speed mode  
At 32 kHz oscillation frequency ..... 2.7 to 5.5 V
- Power dissipation  
In high-speed mode ..... 27.5 mW (typ.)  
(at 16.8 MHz oscillation frequency, at 5 V power source voltage)  
In low-speed mode ..... 1200 μW (typ.)  
(at 32 kHz oscillation frequency, at 3 V power source voltage)
- Operating temperature range ..... -20 to 85°C
- Packages  
SP ..... 64P4B (64-pin 750 mil SDIP)  
FP ..... 64P6N-A (64-pin 14 X 14 mm QFP)  
HP ..... 64P6Q-A (64-pin 10 X 10 mm LQFP)  
KP ..... 64P6U-A (64-pin 14 X 14 mm LQFP)  
WG ..... 64F0G (64-pin 6 X 6 mm FLGA)

<Flash memory mode>

- Power source voltage ..... Vcc = 2.7 to 5.5 V
- Program/Erase voltage ..... Vcc = 2.7 to 5.5 V
- Programming method ..... Programming in unit of byte
- Erasing method ..... Block erasing
- Program/Erase control by software command
- Number of times for programming/erasing ..... 100

■ Notes

The flash memory version cannot be used for application embedded in the MCU card.

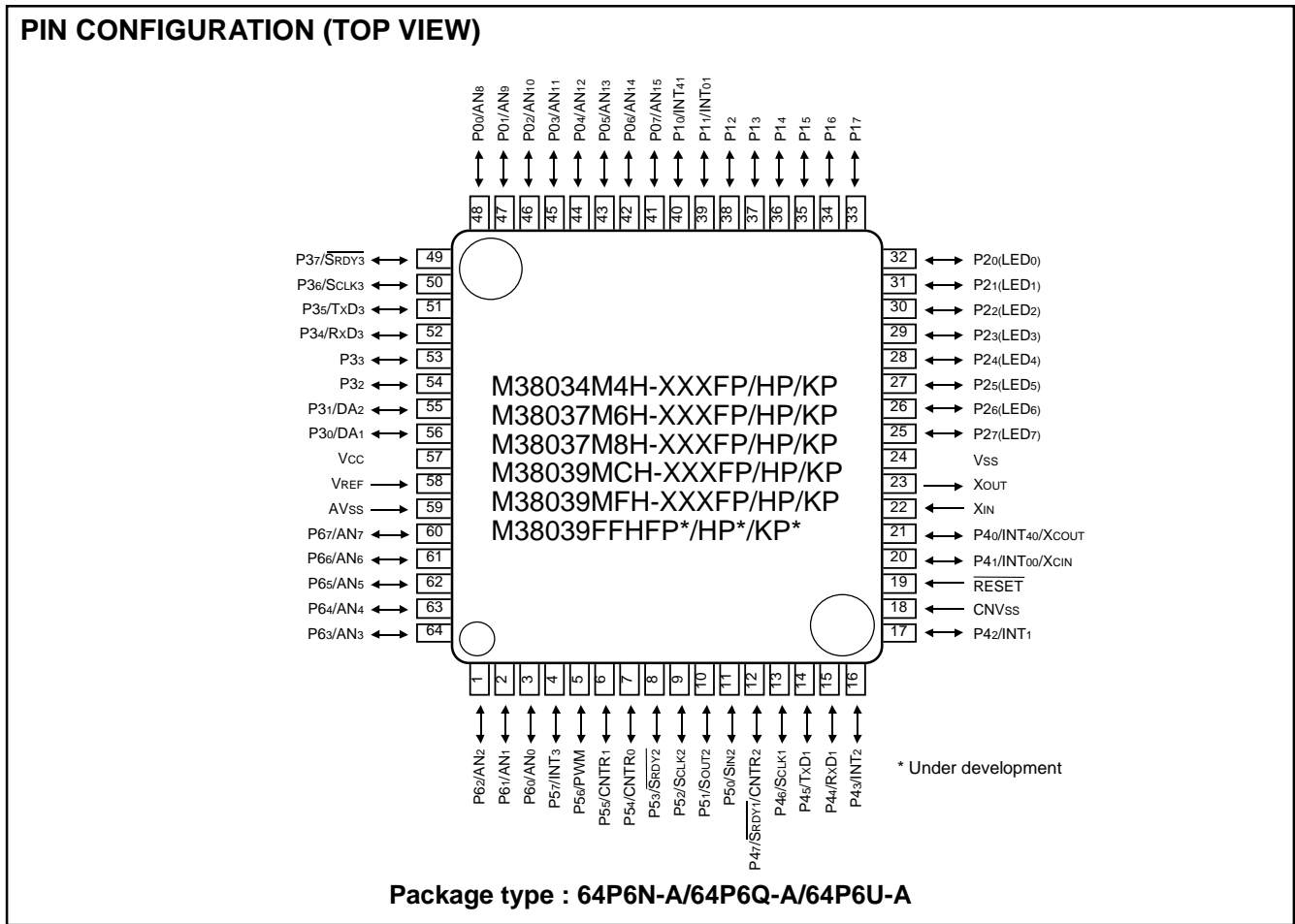

Fig. 1 3803 group (Spec. H) pin configuration

Table 3 List of package (Spec. H)

\* Under development

Package	Product name	ROM size (bytes) ROM size for User in ( )	RAM size (bytes)	Remarks
64P6N-A	M38034M4H-XXXFP	16384 (16254)	640	Mask ROM version
	M38037M6H-XXXFP	24576 (24446)	1024	
	M38037M8H-XXXFP	32768 (32638)	1024	
	M38039MCH-XXXFP	49152 (49022)	2048	
	M38039MFH-XXXFP	61440 (61310)	2048	
	M38039FFHFP*	61440	2048	Flash memory version
	M38039FFFP	61440	2048	Flash memory version (Vcc = 4.0–5.5 V)
64P6Q-A	M38034M4H-XXXHP	16384 (16254)	640	Mask ROM version
	M38037M6H-XXXHP	24576 (24446)	1024	
	M38037M8H-XXXHP	32768 (32638)	1024	
	M38039MCH-XXXHP	49152 (49022)	2048	
	M38039MFH-XXXHP	61440 (61310)	2048	
	M38039FFHHP*	61440	2048	Flash memory version
	M38039FFHP	61440	2048	Flash memory version (Vcc = 4.0–5.5 V)
64P6U-A	M38034M4H-XXXKP	16384 (16254)	640	Mask ROM version
	M38037M6H-XXXKP	24576 (24446)	1024	
	M38037M8H-XXXKP	32768 (32638)	1024	
	M38039MCH-XXXKP	49152 (49022)	2048	
	M38039MFH-XXXKP	61440 (61310)	2048	
	M38039FFHKP*	61440	2048	Flash memory version

**Note:** Since description, features, and electrical characteristics etc. of M38039FFFP and M38039FFHP are not indicated, refer to "3803/3804 Group Data Sheet".

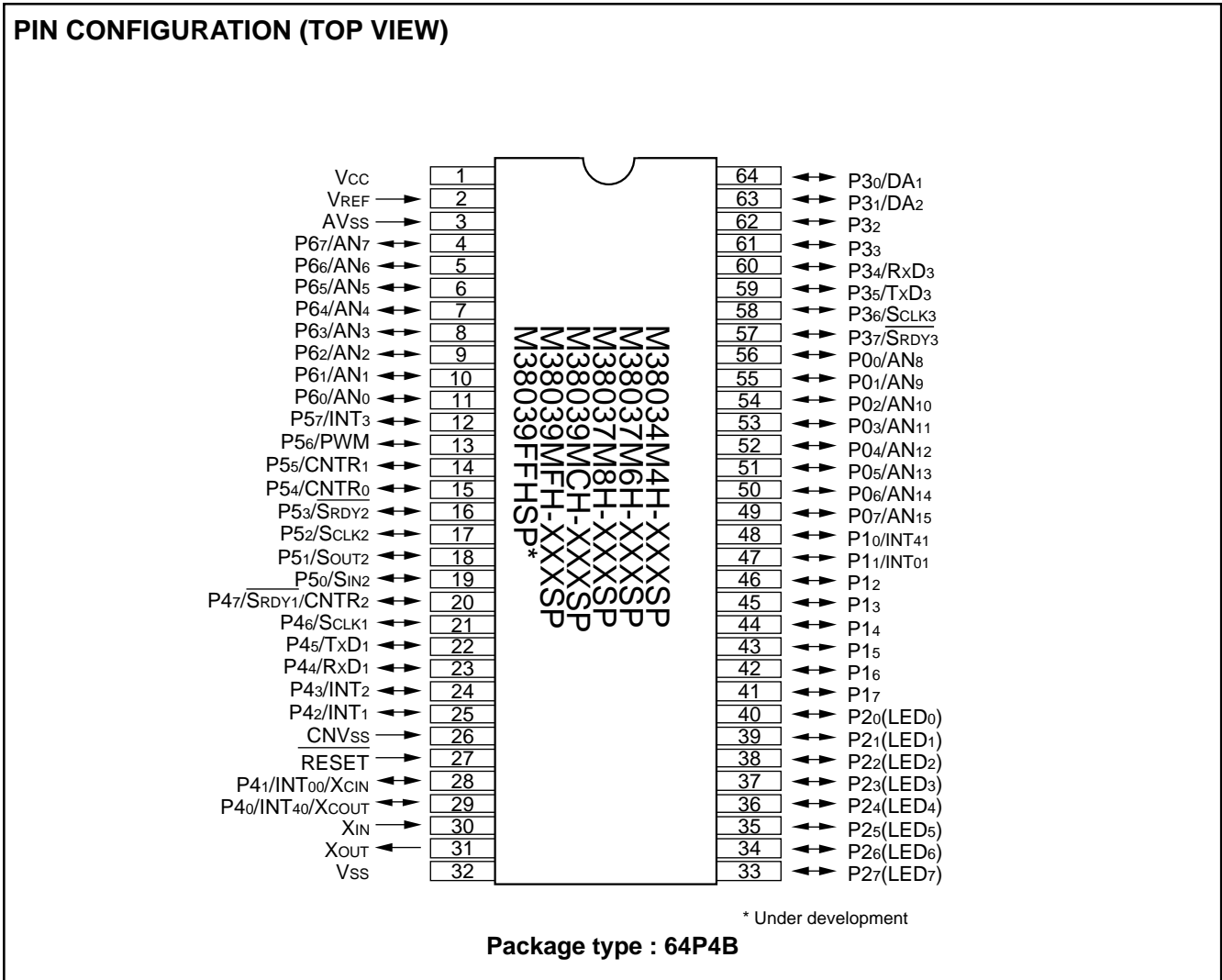

Fig. 2 3803 group (Spec. H) pin configuration

Table 4 List of package (Spec. H)

\* Under development

Package	Product name	ROM size (bytes) ROM size for User in ( )	RAM size (bytes)	Remarks
64P4B	M38034M4H-XXXXSP	16384 (16254)	640	Mask ROM version
	M38037M6H-XXXXSP	24576 (24446)	1024	
	M38037M8H-XXXXSP	32768 (32638)	1024	
	M38039MCH-XXXXSP	49152 (49022)	2048	
	M38039MFH-XXXXSP	61440 (61310)	2048	
	M38039FFHSP*	61440	2048	Flash memory version
	M38039FFSP	61440	2048	Flash memory version (Vcc = 4.0-5.5 V)

**Note:** Since description, features, and electrical characteristics etc. of M38039FFSP are not indicated, refer to “3803/3804 Group Data Sheet”.

**PIN CONFIGURATION (TOP VIEW)**

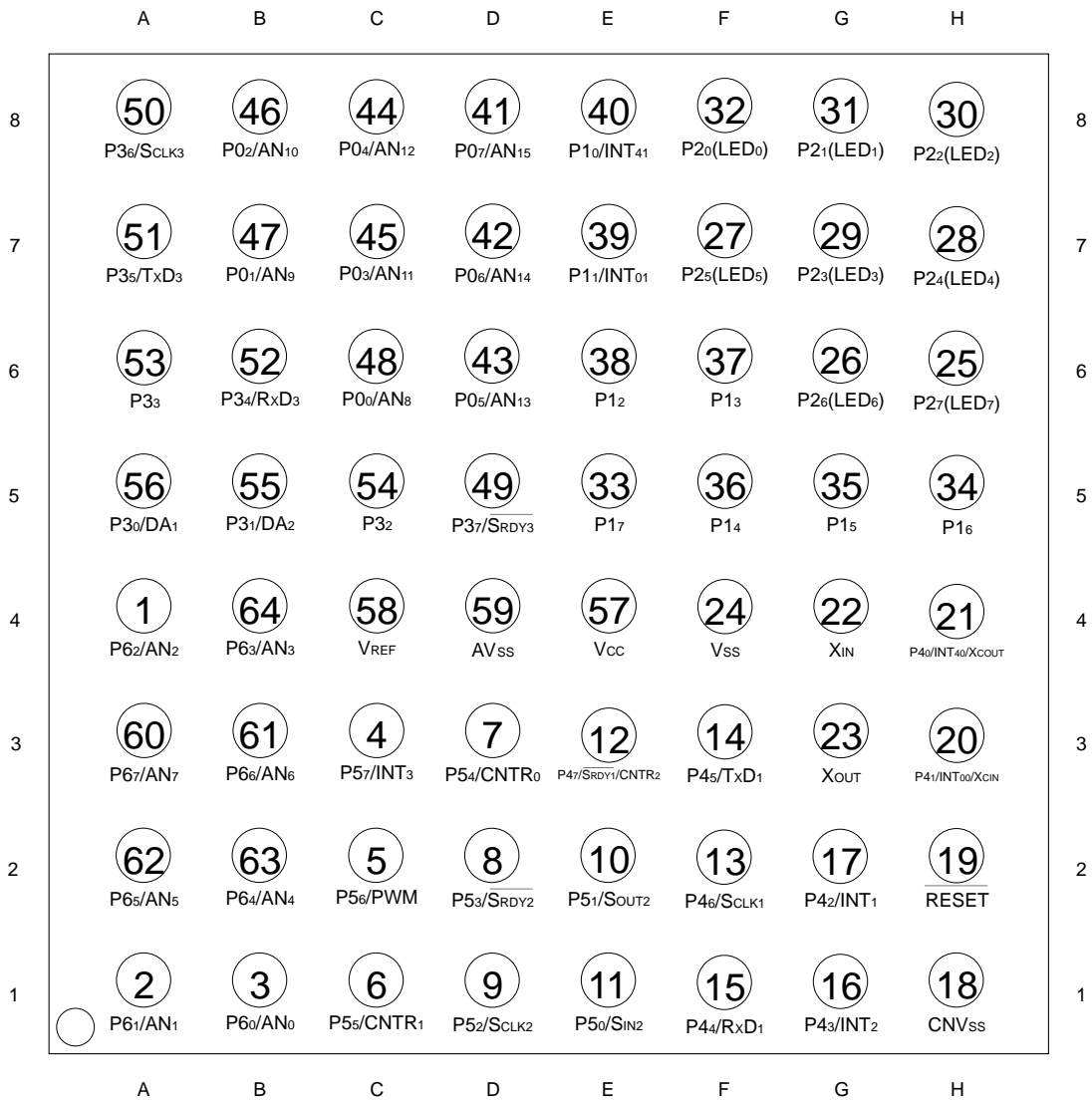

**Package type : 64F0G (TOP)**

\* Under development

Notes: The numbers in circles corresponds with the number on the packages FP/HP/KP.



**Package (TOP VIEW)**

**Fig. 3 3803 group (Spec. H) pin configuration**

**Table 5 List of package (Spec. H)**

\* Under development

Package	Product name	ROM size (bytes) ROM size for User in ( )	RAM size (bytes)	Remarks
64F0G	M38037M8H-XXXWG	32768 (32638)	1024	Mask ROM version
	M38039MFH-XXXWG	61440 (61310)	2048	
	M38039FFHWG*	61440	2048	Flash memory version

FUNCTIONAL BLOCK

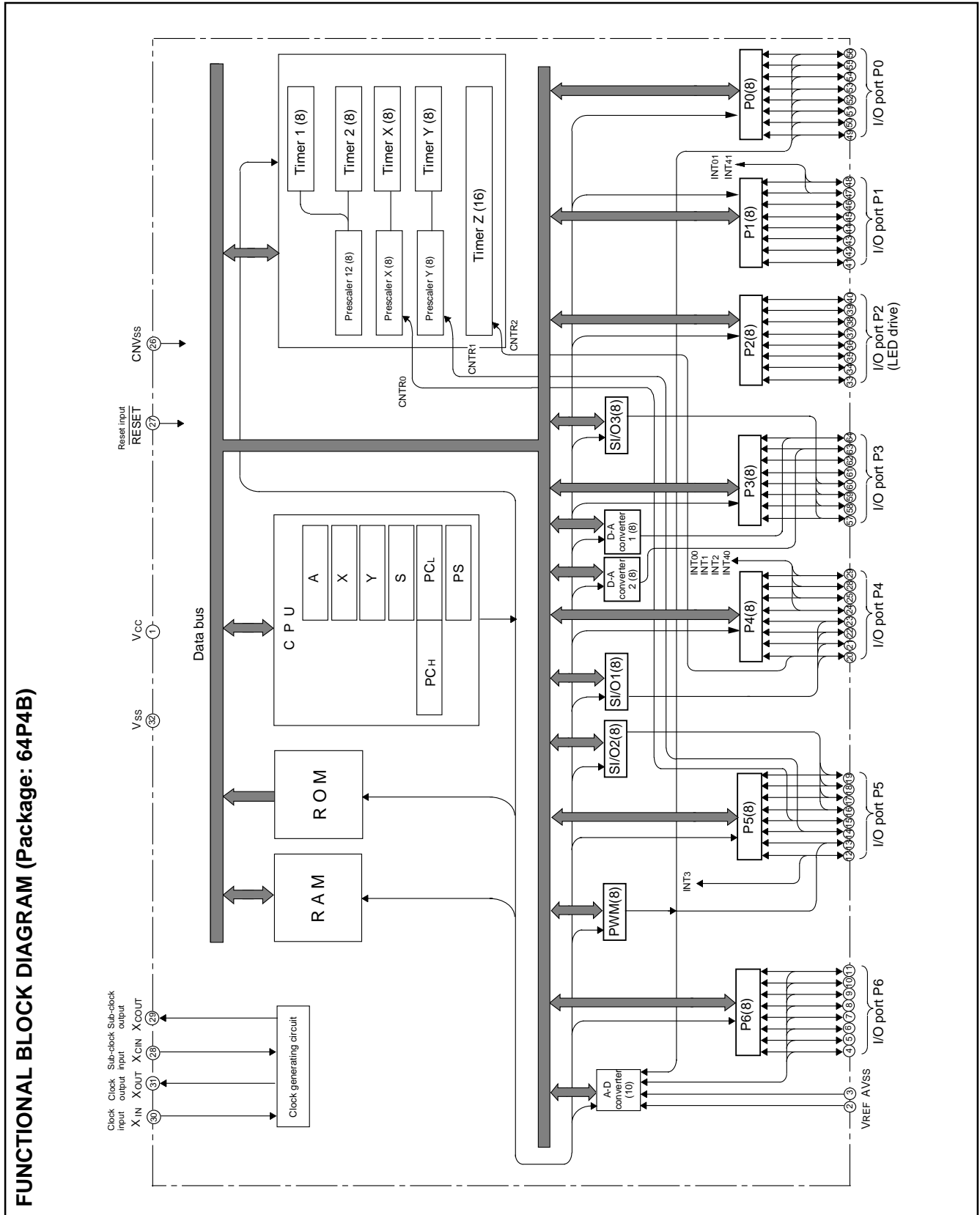

Fig. 4 Functional block diagram

**PIN DESCRIPTION****Table 6 Pin description**

Pin	Name	Functions	
			Function except a port function
VCC, VSS	Power source	•Apply voltage of 1.8 V – 5.5 V to Vcc, and 0 V to Vss. In the flash memory version, apply voltage of 2.7 V–5.5 V to Vcc.	
CNVSS	CNVSS input	•This pin controls the operation mode of the chip. •Normally connected to VSS.	
VREF	Reference voltage	•Reference voltage input pin for A-D and D-A converters.	
AVSS	Analog power source	•Analog power source input pin for A-D and D-A converters. •Connect to VSS.	
RESET	Reset input	•Reset input pin for active “L”.	
XIN	Clock input	•Input and output pins for the clock generating circuit. •Connect a ceramic resonator or quartz-crystal oscillator between the XIN and XOUT pins to set the oscillation frequency.	
XOUT	Clock output	•When an external clock is used, connect the clock source to the XIN pin and leave the XOUT pin open.	
P00/AN8– P07/AN15	I/O port P0	•8-bit CMOS I/O port. •I/O direction register allows each pin to be individually programmed as either input or output.	•A-D converter input pin
P10/INT41 P11/INT01	I/O port P1	•CMOS compatible input level. •CMOS 3-state output structure.	•Interrupt input pin
P12–P17			
P20–P27	I/O port P2	•Pull-up control is enabled in a bit unit. •P20–P27 are enabled to output large current for LED drive.	
P30/DA1 P31/DA2	I/O port P3	•8-bit CMOS I/O port. •I/O direction register allows each pin to be individually programmed as either input or output.	•D-A converter input pin
P32, P33		•CMOS compatible input level. •P30, P31, P34–P37 are CMOS 3-state output structure. •P32, P33 are N-channel open-drain output structure. •Pull-up control of P30, P31, P34–P37 is enabled in a bit unit.	•Serial I/O3 function pin
P34/RxD3 P35/TxD3 P36/SCLK3 P37/SRDY3			
P40/INT40/ XCOUT P41/INT00/ XCIN	I/O port P4	•8-bit CMOS I/O port. •I/O direction register allows each pin to be individually programmed as either input or output. •CMOS compatible input level. •CMOS 3-state output structure. •Pull-up control is enabled in a bit unit.	•Interrupt input pin •Sub-clock generating I/O pin (resonator connected)
P42/INT1 P43/INT2			•Interrupt input pin
P44/RxD1 P45/TxD1 P46/SCLK1			•Serial I/O1 function pin
P47/SRDY1 /CNTR2			•Serial I/O1, timer Z function pin
P50/SIN2 P51/SOUT2 P52/SCLK2 P53/SRDY2	I/O port P5	•8-bit CMOS I/O port. •I/O direction register allows each pin to be individually programmed as either input or output. •CMOS compatible input level. •CMOS 3-state output structure. •Pull-up control is enabled in a bit unit.	•Serial I/O2 function pin
P54/CNTR0			•Timer X function pin
P55/CNTR1			•Timer Y function pin
P56/PWM			•PWM output pin
P57/INT3			•Interrupt input pin
P60/AN0– P67/AN7	I/O port P6		•A-D converter input pin

## PART NUMBERING

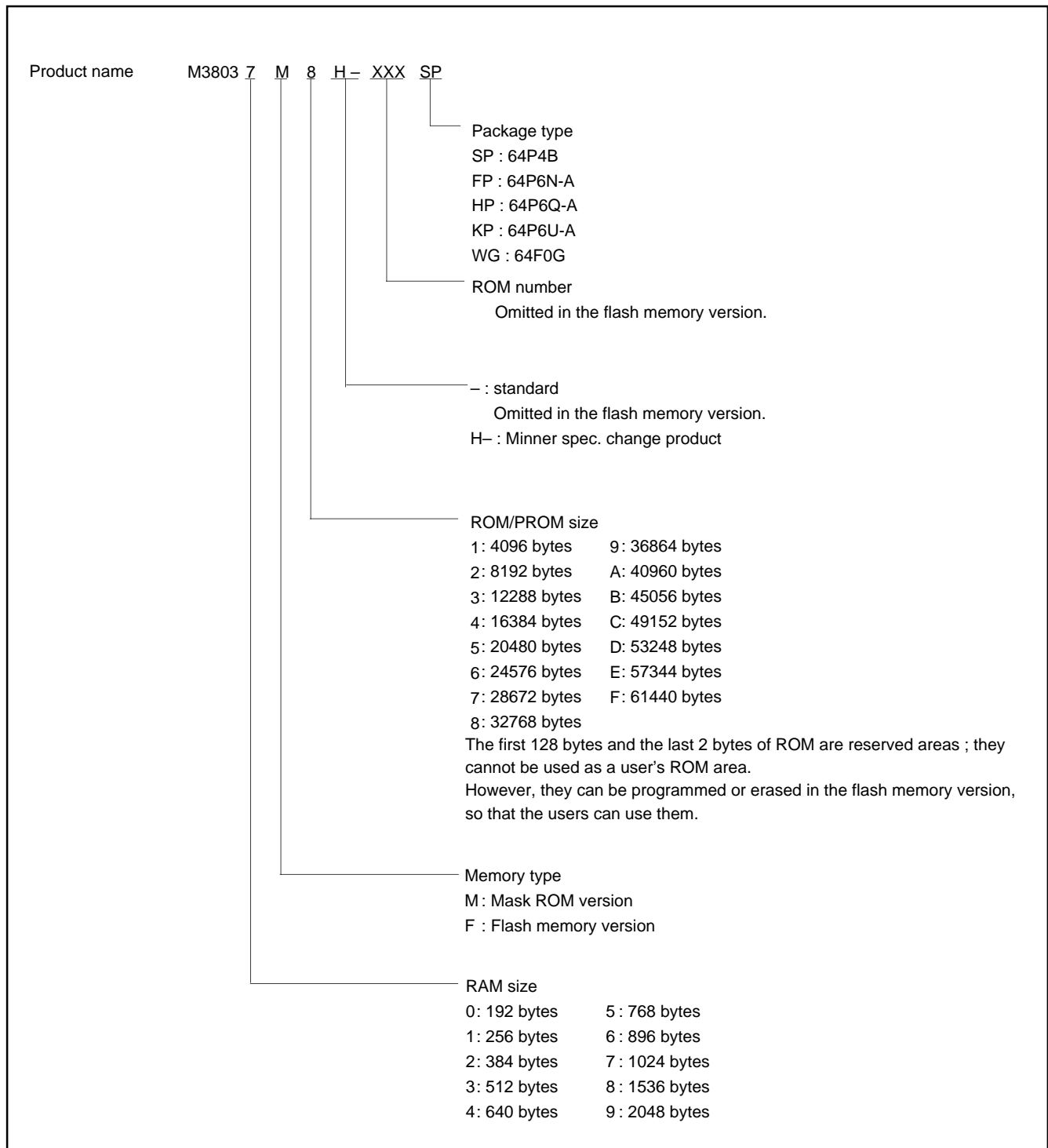

Fig. 5 Part numbering



**GROUP EXPANSION**

Renesas plans to expand the 3803 group (Spec. H) as follows.

**Memory Size**

Flash memory size ..... 60 K bytes  
Mask ROM size ..... 16 K to 60 K bytes  
RAM size ..... 640 to 2048 bytes

**Packages**

64P4B ..... 64-pin shrink plastic-molded DIP  
64P6N-A ..... 0.8 mm-pitch plastic molded QFP  
64P6Q-A ..... 0.5 mm-pitch plastic molded LQFP  
64P6U-A ..... 0.8 mm-pitch plastic molded LQFP  
64F0G ..... 0.65 mm-pitch plastic molded LGA

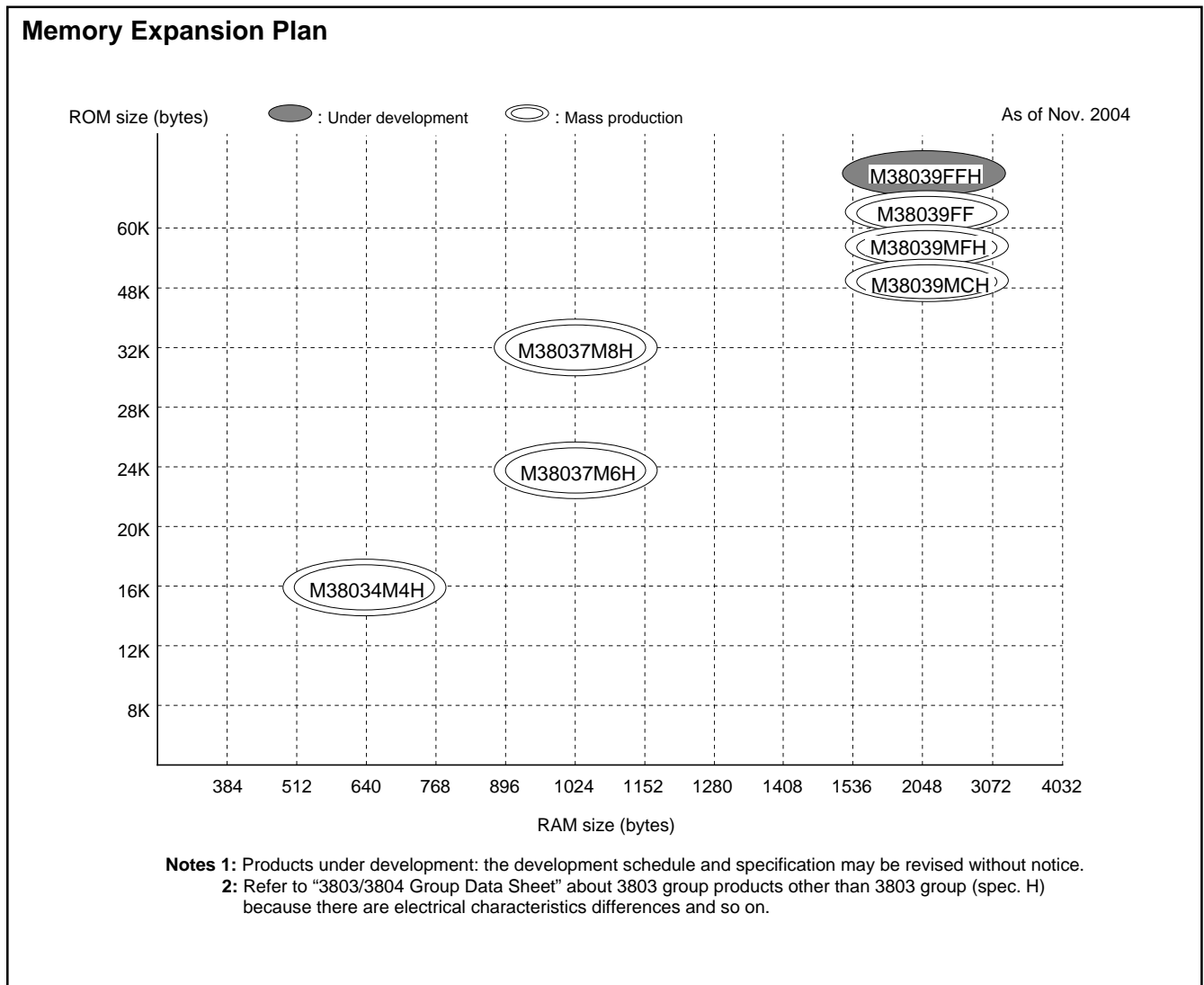

Fig. 6 Memory expansion plan

## FUNCTIONAL DESCRIPTION CENTRAL PROCESSING UNIT (CPU)

The 3803 group (Spec. H) uses the standard 740 Family instruction set. Refer to the table of 740 Family addressing modes and machine instructions or the 740 Family Software Manual for details on the instruction set.

Machine-resident 740 Family instructions are as follows:

The FST and SLW instructions cannot be used.

The STP, WIT, MUL, and DIV instructions can be used.

### [Accumulator (A)]

The accumulator is an 8-bit register. Data operations such as data transfer, etc. are executed mainly through the accumulator.

### [Index Register X (X)]

The index register X is an 8-bit register. In the index addressing modes, the value of the OPERAND is added to the contents of register X and specifies the real address.

### [Index Register Y (Y)]

The index register Y is an 8-bit register. In partial instruction, the value of the OPERAND is added to the contents of register Y and specifies the real address.

### [Stack Pointer (S)]

The stack pointer is an 8-bit register used during subroutine calls and interrupts. This register indicates start address of stored area (stack) for storing registers during subroutine calls and interrupts. The low-order 8 bits of the stack address are determined by the contents of the stack pointer. The high-order 8 bits of the stack address are determined by the stack page selection bit. If the stack page selection bit is "0", the high-order 8 bits becomes "0016". If the stack page selection bit is "1", the high-order 8 bits becomes "0116".

The operations of pushing register contents onto the stack and popping them from the stack are shown in Figure 8.

Store registers other than those described in Figure 7 with program when the user needs them during interrupts or subroutine calls (see Table 7).

### [Program Counter (PC)]

The program counter is a 16-bit counter consisting of two 8-bit registers PCH and PCL. It is used to indicate the address of the next instruction to be executed.

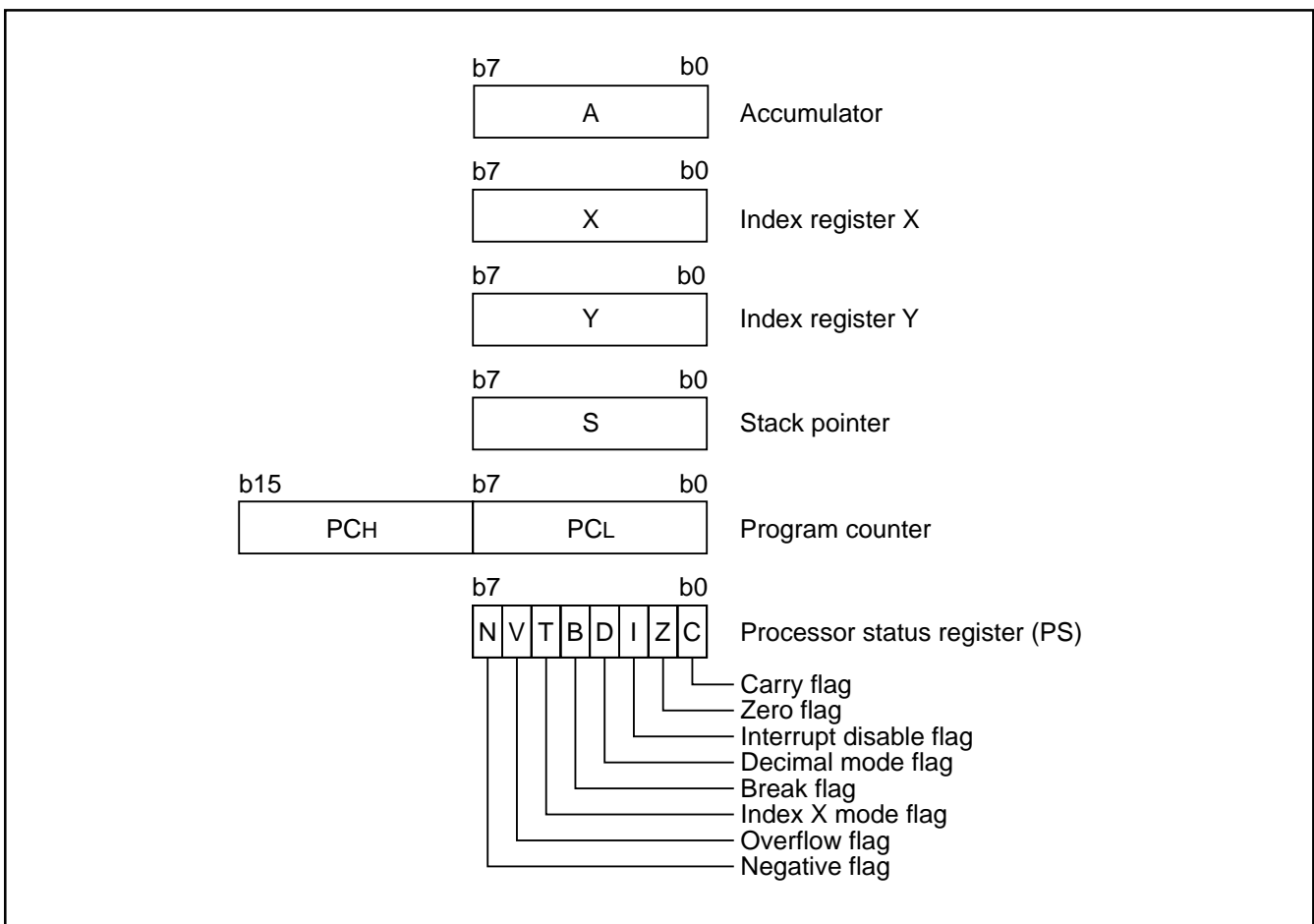

Fig.7 740 Family CPU register structure

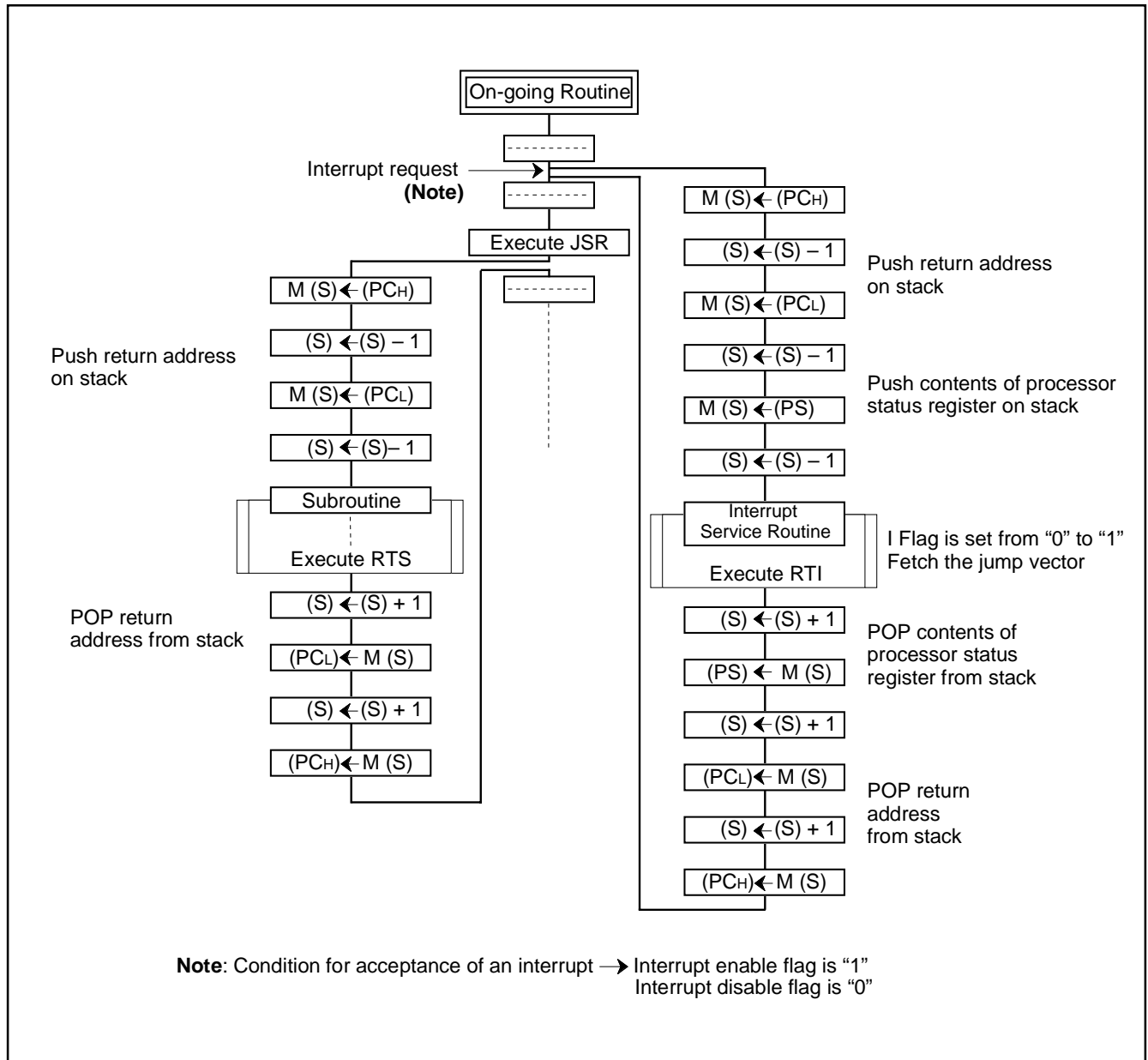

Fig. 8 Register push and pop at interrupt generation and subroutine call

Table 7 Push and pop instructions of accumulator or processor status register

	Push instruction to stack	Pop instruction from stack
Accumulator	PHA	PLA
Processor status register	PHP	PLP

**[Processor status register (PS)]**

The processor status register is an 8-bit register consisting of 5 flags which indicate the status of the processor after an arithmetic operation and 3 flags which decide MCU operation. Branch operations can be performed by testing the Carry (C) flag, Zero (Z) flag, Overflow (V) flag, or the Negative (N) flag. In decimal mode, the Z, V, N flags are not valid.

## •Bit 0: Carry flag (C)

The C flag contains a carry or borrow generated by the arithmetic logic unit (ALU) immediately after an arithmetic operation. It can also be changed by a shift or rotate instruction.

## •Bit 1: Zero flag (Z)

The Z flag is set if the result of an immediate arithmetic operation or a data transfer is "0", and cleared if the result is anything other than "0".

## •Bit 2: Interrupt disable flag (I)

The I flag disables all interrupts except for the interrupt generated by the BRK instruction.

Interrupts are disabled when the I flag is "1".

## •Bit 3: Decimal mode flag (D)

The D flag determines whether additions and subtractions are executed in binary or decimal. Binary arithmetic is executed when this flag is "0"; decimal arithmetic is executed when it is "1".

Decimal correction is automatic in decimal mode. Only the ADC and SBC instructions can execute decimal arithmetic.

## •Bit 4: Break flag (B)

The B flag is used to indicate that the current interrupt was generated by the BRK instruction. The BRK flag in the processor status register is always "0". When the BRK instruction is used to generate an interrupt, the processor status register is pushed onto the stack with the break flag set to "1".

## •Bit 5: Index X mode flag (T)

When the T flag is "0", arithmetic operations are performed between accumulator and memory. When the T flag is "1", direct arithmetic operations and direct data transfers are enabled between memory locations.

## •Bit 6: Overflow flag (V)

The V flag is used during the addition or subtraction of one byte of signed data. It is set if the result exceeds +127 to -128. When the BIT instruction is executed, bit 6 of the memory location operated on by the BIT instruction is stored in the overflow flag.

## •Bit 7: Negative flag (N)

The N flag is set if the result of an arithmetic operation or data transfer is negative. When the BIT instruction is executed, bit 7 of the memory location operated on by the BIT instruction is stored in the negative flag.

**Table 8 Set and clear instructions of each bit of processor status register**

	C flag	Z flag	I flag	D flag	B flag	T flag	V flag	N flag
Set instruction	SEC	–	SEI	SED	–	SET	–	–
Clear instruction	CLC	–	CLI	CLD	–	CLT	CLV	–

**[CPU Mode Register (CPUM)] 003B16**

The CPU mode register contains the stack page selection bit, etc.

The CPU mode register is allocated at address 003B16.

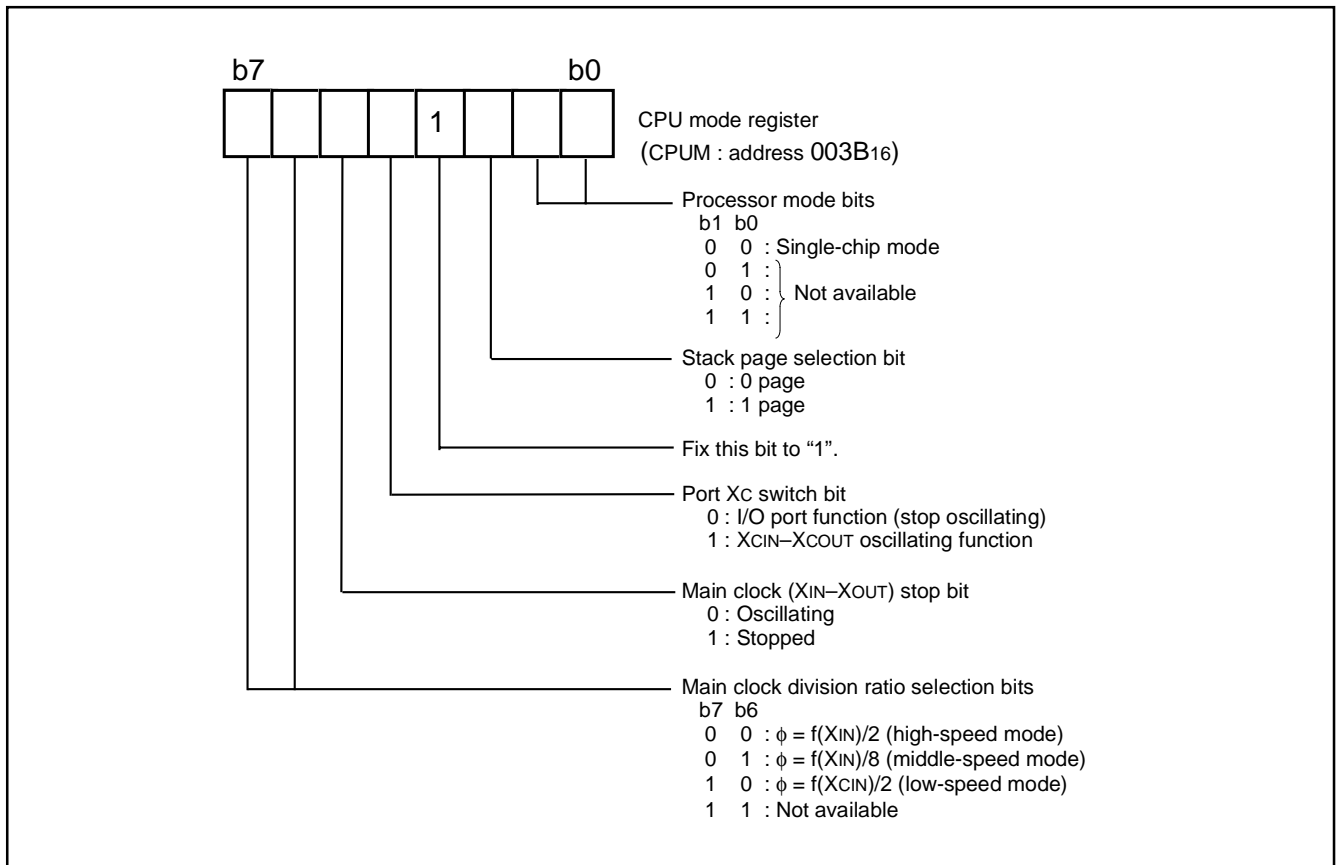

Fig. 9 Structure of CPU mode register

**MISRГ****(1) Bit 0 of address 0010<sub>16</sub>: Oscillation stabilizing time set after STP instruction released bit**

When the MCU stops the clock oscillation by the STP instruction and the STP instruction has been released by an external interrupt source, usually, the fixed values of Timer 1 and Prescaler 12 (Timer 1 = 01<sub>16</sub>, Prescaler 12 = FF<sub>16</sub>) are automatically reloaded in order for the oscillation to stabilize. The user can inhibit the automatic setting by setting "1" to bit 0 of MISRG (address 0010<sub>16</sub>). However, by setting this bit to "1", the previous values, set just before the STP instruction was executed, will remain in Timer 1 and Prescaler 12. Therefore, you will need to set an appropriate value to each register, in accordance with the oscillation stabilizing time, before executing the STP instruction.

Figure 10 shows the structure of MISRG.

**(2) Bits 1, 2, 3 of address 0010<sub>16</sub>: Middle-speed Mode Automatic Switch Function**

In order to switch the clock mode of an MCU which has a sub-clock, the following procedure is necessary:

set CPU mode register (003B<sub>16</sub>) --> start main clock oscillation --> wait for oscillation stabilization --> switch to middle-speed mode (or high-speed mode).

However, the 3803 group (Spec. H) has the built-in function which automatically switches from low to middle-speed mode by program.

**●Middle-speed mode automatic switch by program**

The middle-speed mode can also be automatically switched by program while operating in low-speed mode. By setting the middle-speed automatic switch start bit (bit 3) of MISRG (address 0010<sub>16</sub>) to "1" in the condition that the middle-speed mode automatic switch set bit is "1" while operating in low-speed mode, the MCU will automatically switch to middle-speed mode. In this case, the oscillation stabilizing time of the main clock can be selected by the middle-speed automatic switch wait time set bit (bit 2) of MISRG (address 0010<sub>16</sub>).

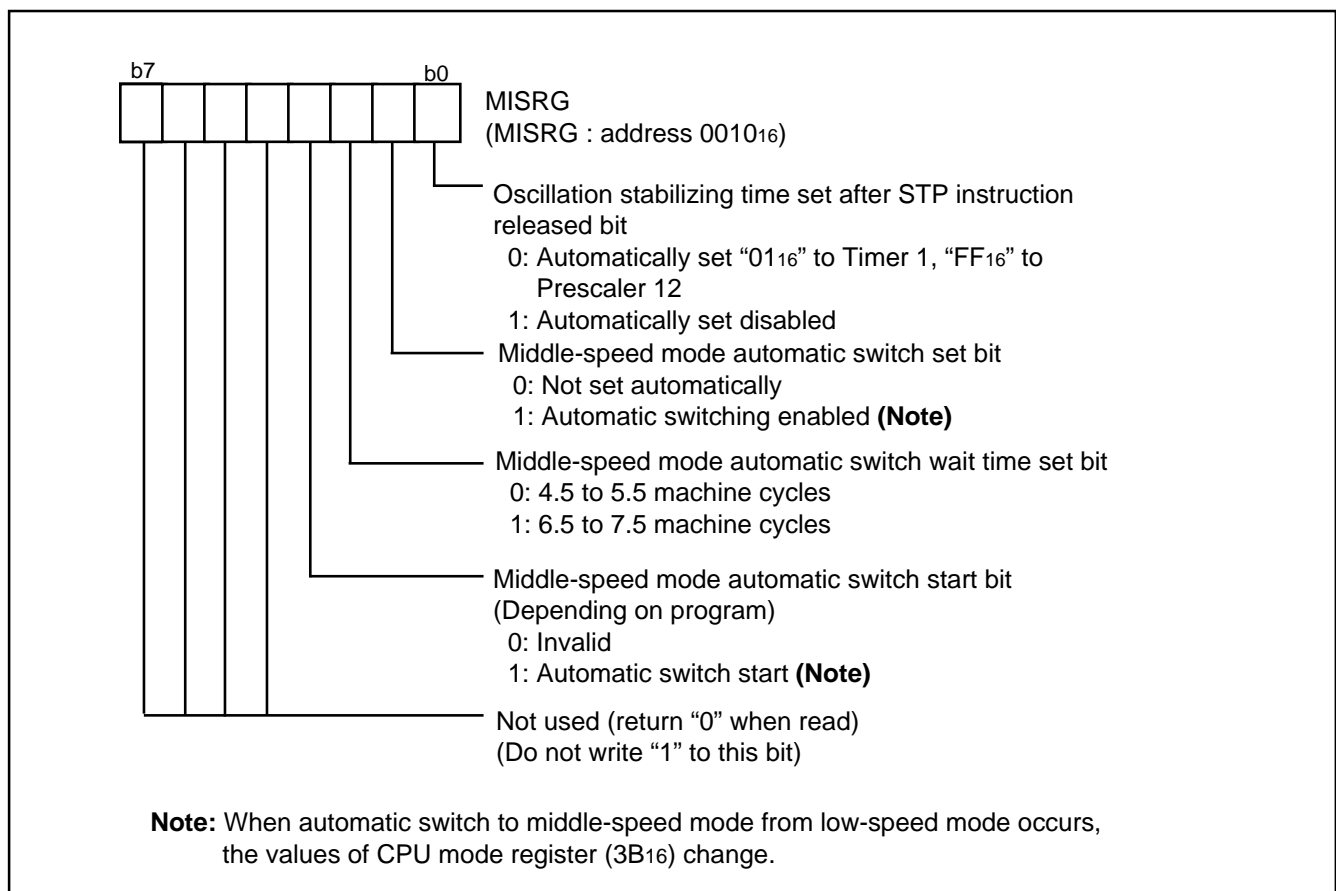

Fig. 10 Structure of MISRG

**MEMORY**

**Special Function Register (SFR) Area**

The Special Function Register area in the zero page contains control registers such as I/O ports and timers.

**RAM**

RAM is used for data storage and for stack area of subroutine calls and interrupts.

**ROM**

The first 128 bytes and the last 2 bytes of ROM are reserved for device testing and the rest is a user area for storing programs. The reserved ROM area can program/erase in the flash memory version.

**Interrupt Vector Area**

The interrupt vector area contains reset and interrupt vectors.

**Zero Page**

Access to this area with only 2 bytes is possible in the zero page addressing mode.

**Special Page**

Access to this area with only 2 bytes is possible in the special page addressing mode.

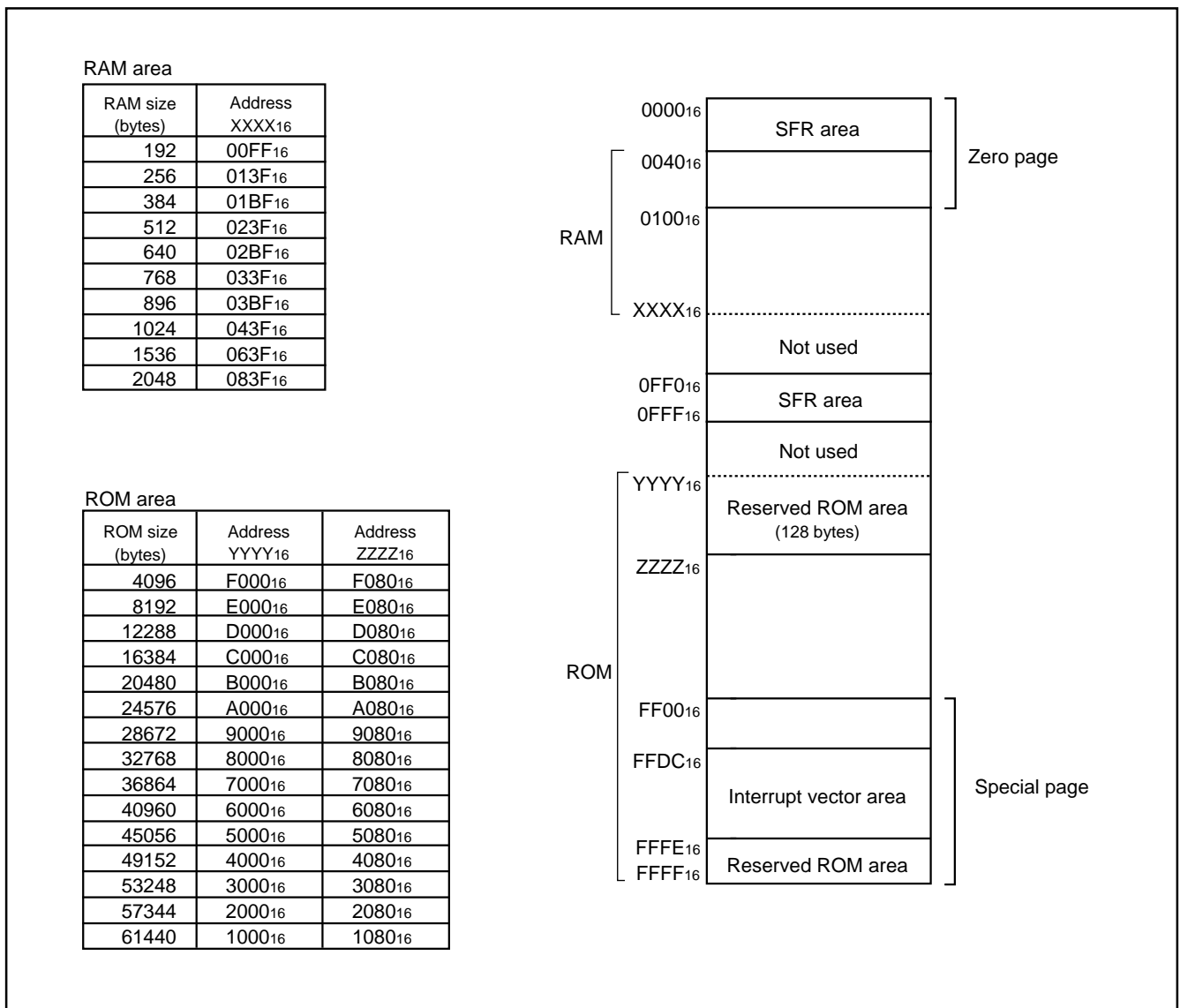

Fig. 11 Memory map diagram

0000 <sub>16</sub>	Port P0 (P0)	0020 <sub>16</sub>	Prescaler 12 (PRE12)
0001 <sub>16</sub>	Port P0 direction register (P0D)	0021 <sub>16</sub>	Timer 1 (T1)
0002 <sub>16</sub>	Port P1 (P1)	0022 <sub>16</sub>	Timer 2 (T2)
0003 <sub>16</sub>	Port P1 direction register (P1D)	0023 <sub>16</sub>	Timer XY mode register (TM)
0004 <sub>16</sub>	Port P2 (P2)	0024 <sub>16</sub>	Prescaler X (PREX)
0005 <sub>16</sub>	Port P2 direction register (P2D)	0025 <sub>16</sub>	Timer X (TX)
0006 <sub>16</sub>	Port P3 (P3)	0026 <sub>16</sub>	Prescaler Y (PREY)
0007 <sub>16</sub>	Port P3 direction register (P3D)	0027 <sub>16</sub>	Timer Y (TY)
0008 <sub>16</sub>	Port P4 (P4)	0028 <sub>16</sub>	Timer Z low-order (TZL)
0009 <sub>16</sub>	Port P4 direction register (P4D)	0029 <sub>16</sub>	Timer Z high-order (TZH)
000A <sub>16</sub>	Port P5 (P5)	002A <sub>16</sub>	Timer Z mode register (TZM)
000B <sub>16</sub>	Port P5 direction register (P5D)	002B <sub>16</sub>	PWM control register (PWMCON)
000C <sub>16</sub>	Port P6 (P6)	002C <sub>16</sub>	PWM prescaler (PREPWM)
000D <sub>16</sub>	Port P6 direction register (P6D)	002D <sub>16</sub>	PWM register (PWM)
000E <sub>16</sub>	Timer 12, X count source selection register (T12XCSS)	002E <sub>16</sub>	
000F <sub>16</sub>	Timer Y, Z count source selection register (TYZCSS)	002F <sub>16</sub>	Baud rate generator 3 (BRG3)
0010 <sub>16</sub>	MISRG	0030 <sub>16</sub>	Transmit/Receive buffer register 3 (TB3/RB3)
0011 <sub>16</sub>	Reserved *	0031 <sub>16</sub>	Serial I/O3 status register (SIO3STS)
0012 <sub>16</sub>	Reserved *	0032 <sub>16</sub>	Serial I/O3 control register (SIO3CON)
0013 <sub>16</sub>	Reserved *	0033 <sub>16</sub>	UART3 control register (UART3CON)
0014 <sub>16</sub>	Reserved *	0034 <sub>16</sub>	AD/DA control register (ADCON)
0015 <sub>16</sub>	Reserved *	0035 <sub>16</sub>	A-D conversion register 1 (AD1)
0016 <sub>16</sub>	Reserved *	0036 <sub>16</sub>	D-A1 conversion register (DA1)
0017 <sub>16</sub>	Reserved *	0037 <sub>16</sub>	D-A2 conversion register (DA2)
0018 <sub>16</sub>	Transmit/Receive buffer register 1 (TB1/RB1)	0038 <sub>16</sub>	A-D conversion register 2 (AD2)
0019 <sub>16</sub>	Serial I/O1 status register (SIO1STS)	0039 <sub>16</sub>	Interrupt source selection register (INTSEL)
001A <sub>16</sub>	Serial I/O1 control register (SIO1CON)	003A <sub>16</sub>	Interrupt edge selection register (INTEDGE)
001B <sub>16</sub>	UART1 control register (UART1CON)	003B <sub>16</sub>	CPU mode register (CPUM)
001C <sub>16</sub>	Baud rate generator (BRG1)	003C <sub>16</sub>	Interrupt request register 1 (IREQ1)
001D <sub>16</sub>	Serial I/O2 control register (SIO2CON)	003D <sub>16</sub>	Interrupt request register 2 (IREQ2)
001E <sub>16</sub>	Watchdog timer control register (WDTCN)	003E <sub>16</sub>	Interrupt control register 1 (ICON1)
001F <sub>16</sub>	Serial I/O2 register (SIO2)	003F <sub>16</sub>	Interrupt control register 2 (ICON2)
0FE0 <sub>16</sub>	Flash memory control register 0 (FMCR0)	0FF0 <sub>16</sub>	Port P0 pull-up control register (PULL0)
0FE1 <sub>16</sub>	Flash memory control register 1 (FMCR1)	0FF1 <sub>16</sub>	Port P1 pull-up control register (PULL1)
0FE2 <sub>16</sub>	Flash memory control register 2 (FMCR2)	0FF2 <sub>16</sub>	Port P2 pull-up control register (PULL2)
0FE3 <sub>16</sub>	Reserved *	0FF3 <sub>16</sub>	Port P3 pull-up control register (PULL3)
0FE4 <sub>16</sub>	Reserved *	0FF4 <sub>16</sub>	Port P4 pull-up control register (PULL4)
0FE5 <sub>16</sub>	Reserved *	0FF5 <sub>16</sub>	Port P5 pull-up control register (PULL5)
0FE6 <sub>16</sub>	Reserved *	0FF6 <sub>16</sub>	Port P6 pull-up control register (PULL6)
0FE7 <sub>16</sub>	Reserved *		
0FE8 <sub>16</sub>	Reserved *		
0FE9 <sub>16</sub>	Reserved *		
0FEA <sub>16</sub>	Reserved *		
0FEB <sub>16</sub>	Reserved *		
0FEC <sub>16</sub>	Reserved *		
0FED <sub>16</sub>	Reserved *		
0FEE <sub>16</sub>	Reserved *		
0FEF <sub>16</sub>	Reserved *		

\* Reserved area: Do not write any data to these addresses, because these areas are reserved.

Fig. 12 Memory map of special function register (SFR)



**I/O PORTS**

The I/O ports have direction registers which determine the input/output direction of each individual pin. Each bit in a direction register corresponds to one pin, and each pin can be set to be input port or output port.

When "0" is written to the bit corresponding to a pin, that pin be-

comes an input pin. When "1" is written to that bit, that pin becomes an output pin.

If data is read from a pin which is set to output, the value of the port output latch is read, not the value of the pin itself. Pins set to input are floating. If a pin set to input is written to, only the port output latch is written to and the pin remains floating.

**Table 9 I/O port function**

Pin	Name	I/O Structure	Non-Port Function	Related SFRs	Ref.No.	
P00/AN8–P07/AN15	Port P0	CMOS compatible input level	A-D converter input	AD/DA control register	(1)	
P10/INT41 P11/INT01	Port P1	CMOS 3-state output	External interrupt input	Interrupt edge selection register	(2)	
P12–P17					(3)	
P20/LED0– P27/LED7	Port P2					
P30/DA1 P31/DA2	Port P3	CMOS compatible input level	D-A converter output	AD/DA control register	(4)	
P32 P33		CMOS 3-state output			(5)	
P34/RxD3 P35/TxD3 P36/SCLK3 P37/SRDY3		CMOS compatible input level	Serial I/O3 function I/O	Serial I/O3 control register	(6)	
		CMOS 3-state output		UART3 control register	(7)	
				UART3 control register	(8)	
					(9)	
P40/INT40/XCIN P41/INT00/XCOUT	Port P4	CMOS compatible input level	External interrupt input	Interrupt edge selection register	(10)	
			CMOS 3-state output	Sub-clock generating circuit	CPU mode register	(11)
P42/INT1 P43/INT2			External interrupt input	Interrupt edge selection register	(2)	
P44/RxD1 P45/TxD1 P46/SCLK1			Serial I/O1 function I/O	Serial I/O1 control register	(6)	
			UART1 control register	(7)		
				UART1 control register	(8)	
P47/SRDY1/CNTR2			Serial I/O1 function I/O	Serial I/O1 control register	(12)	
			Timer Z function I/O	Timer Z mode register		
P50/SIN2 P51/SOUT2 P52/SCLK2 P53/SRDY2	Port P5	CMOS compatible input level	Serial I/O2 function I/O	Serial I/O2 control register	(13)	
			CMOS 3-state output			(14)
						(15)
						(16)
P54/CNTR0 P55/CNTR1			Timer X, Y function I/O	Timer XY mode register	(17)	
P56/PWM	PWM output	PWM control register	(18)			
P57/INT3	External interrupt input	Interrupt edge selection register	(2)			
P60/AN0–P67/AN7	Port P6	CMOS compatible input level	A-D converter input	AD/DA control register	(1)	
		CMOS 3-state output				

**Notes 1:** Refer to the applicable sections how to use double-function ports as function I/O ports.

**2:** Make sure that the input level at each pin is either 0 V or VCC during execution of the STP instruction.

When an input level is at an intermediate potential, a current will flow from VCC to VSS through the input-stage gate.

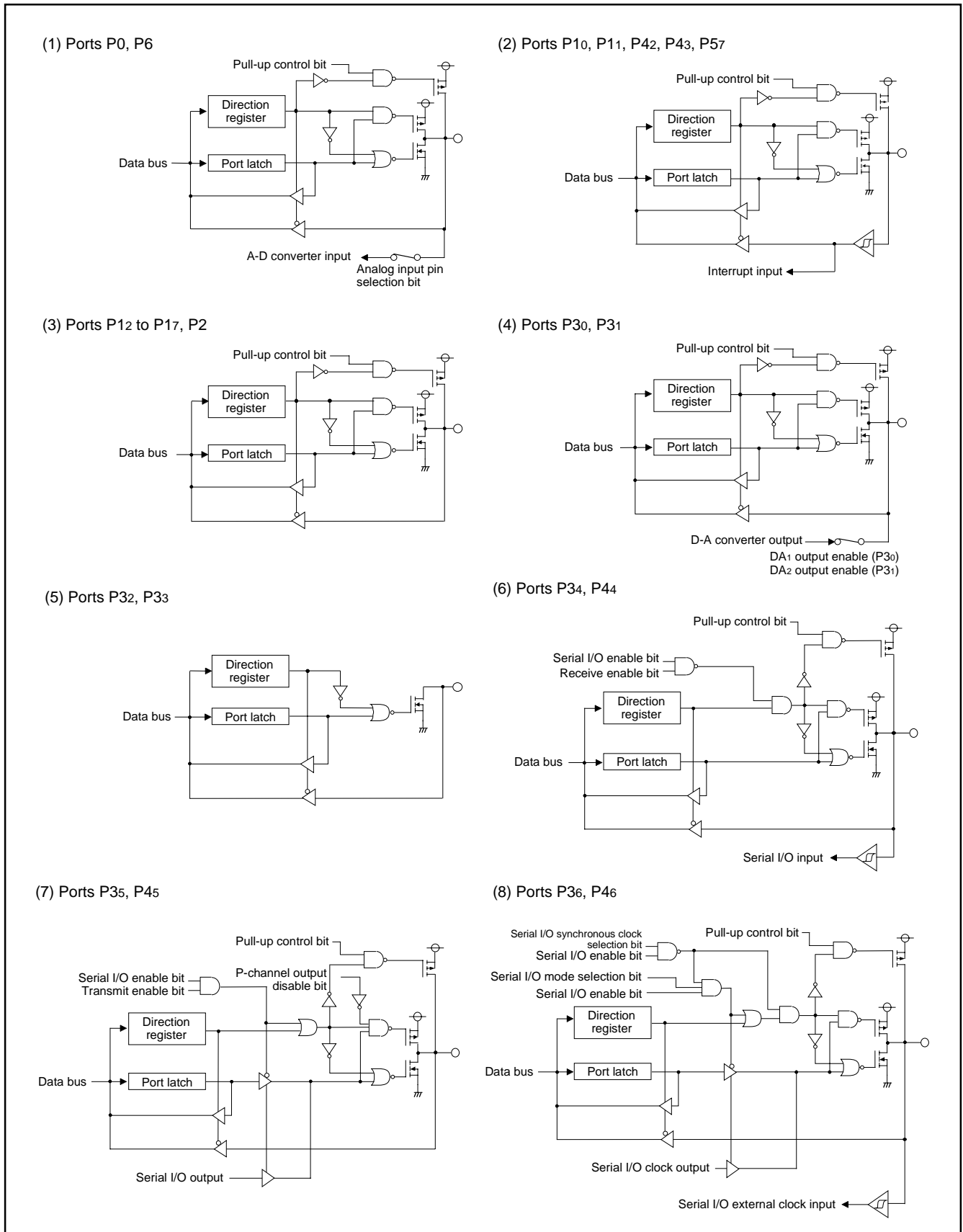
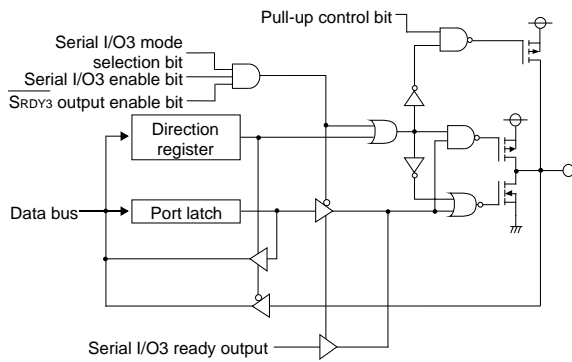
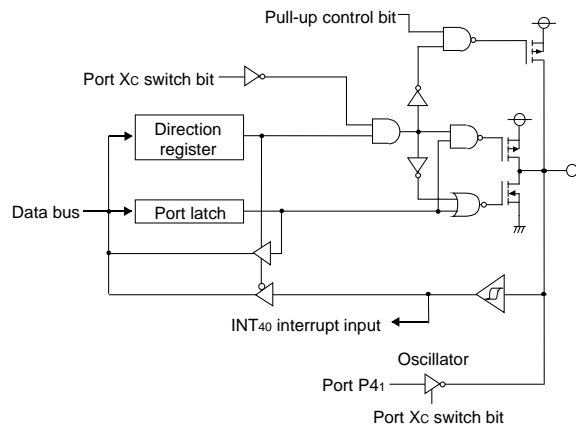

Fig. 13 Port block diagram (1)

(9) Port P37



(10) Port P40



(11) Port P41

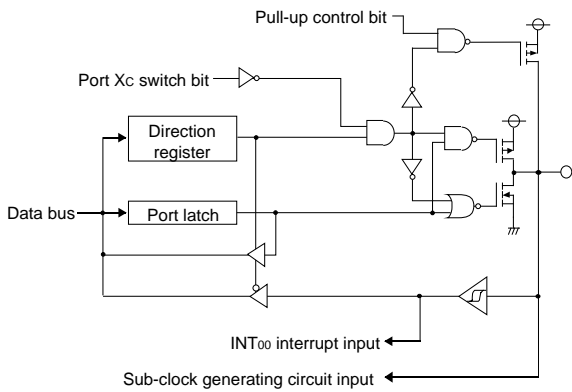

(12) Port P47

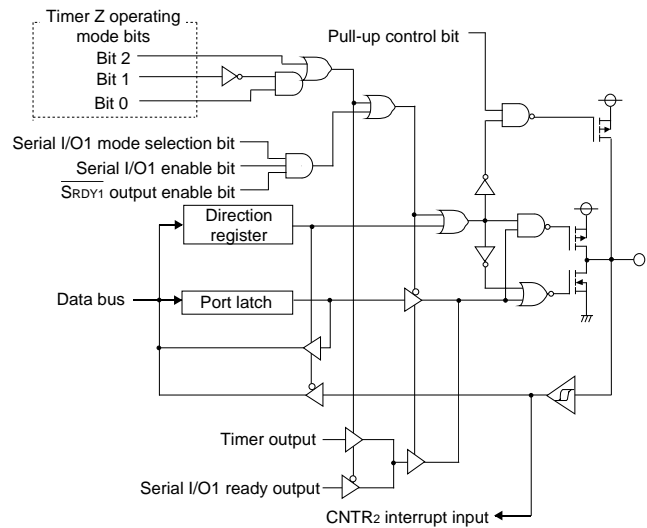

(13) Port P50

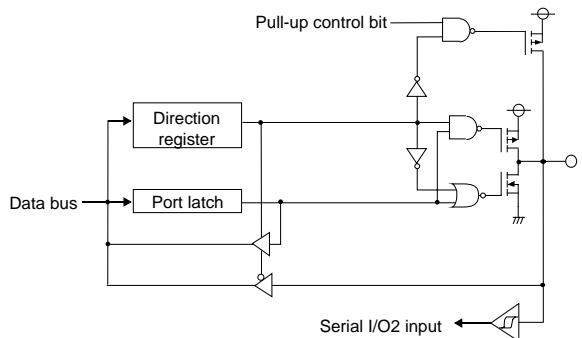

(14) Port P51

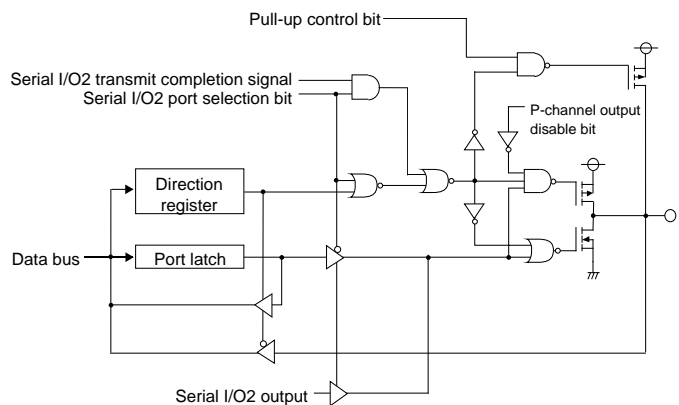

Fig. 14 Port block diagram (2)

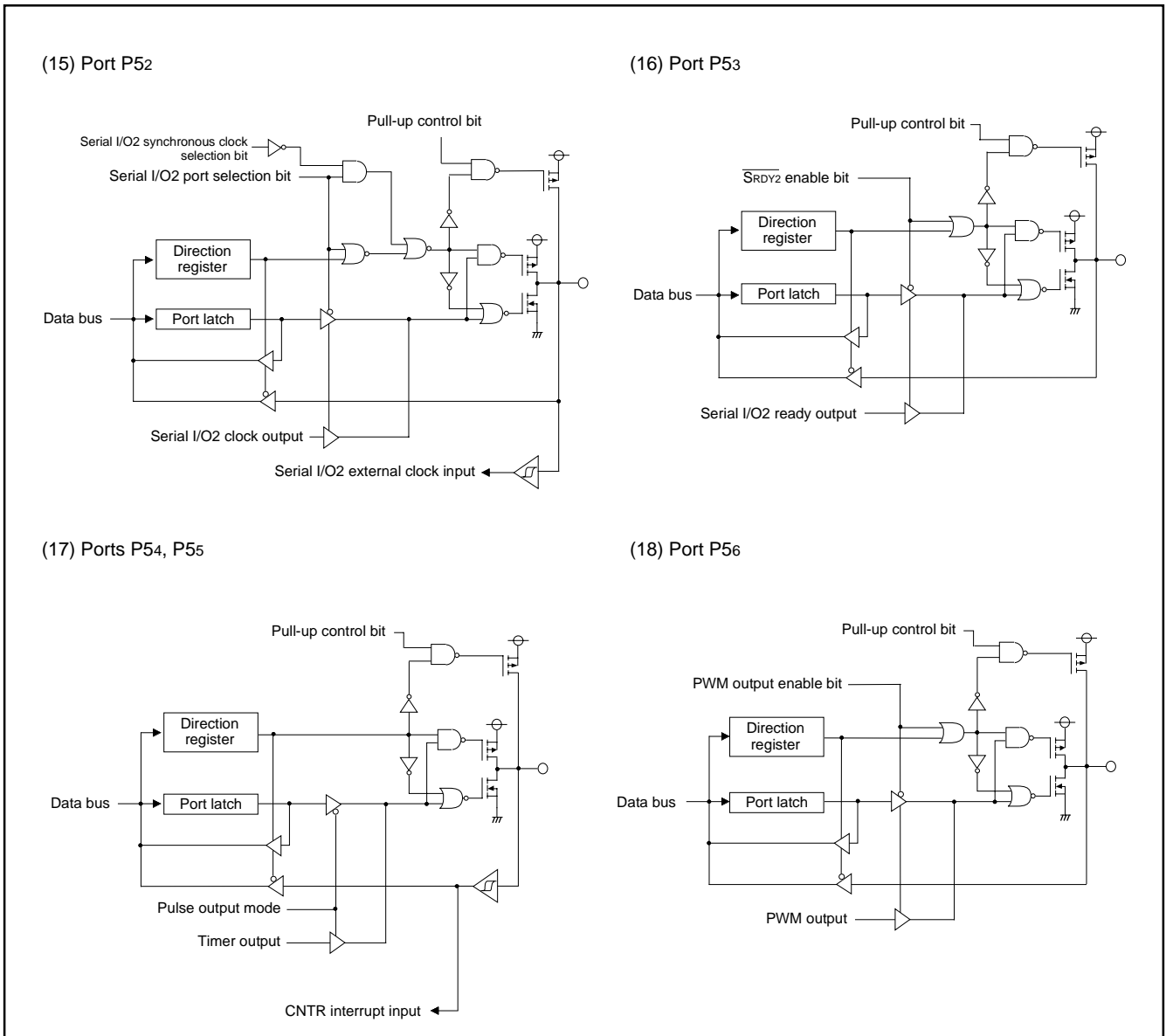

Fig. 15 Port block diagram (3)

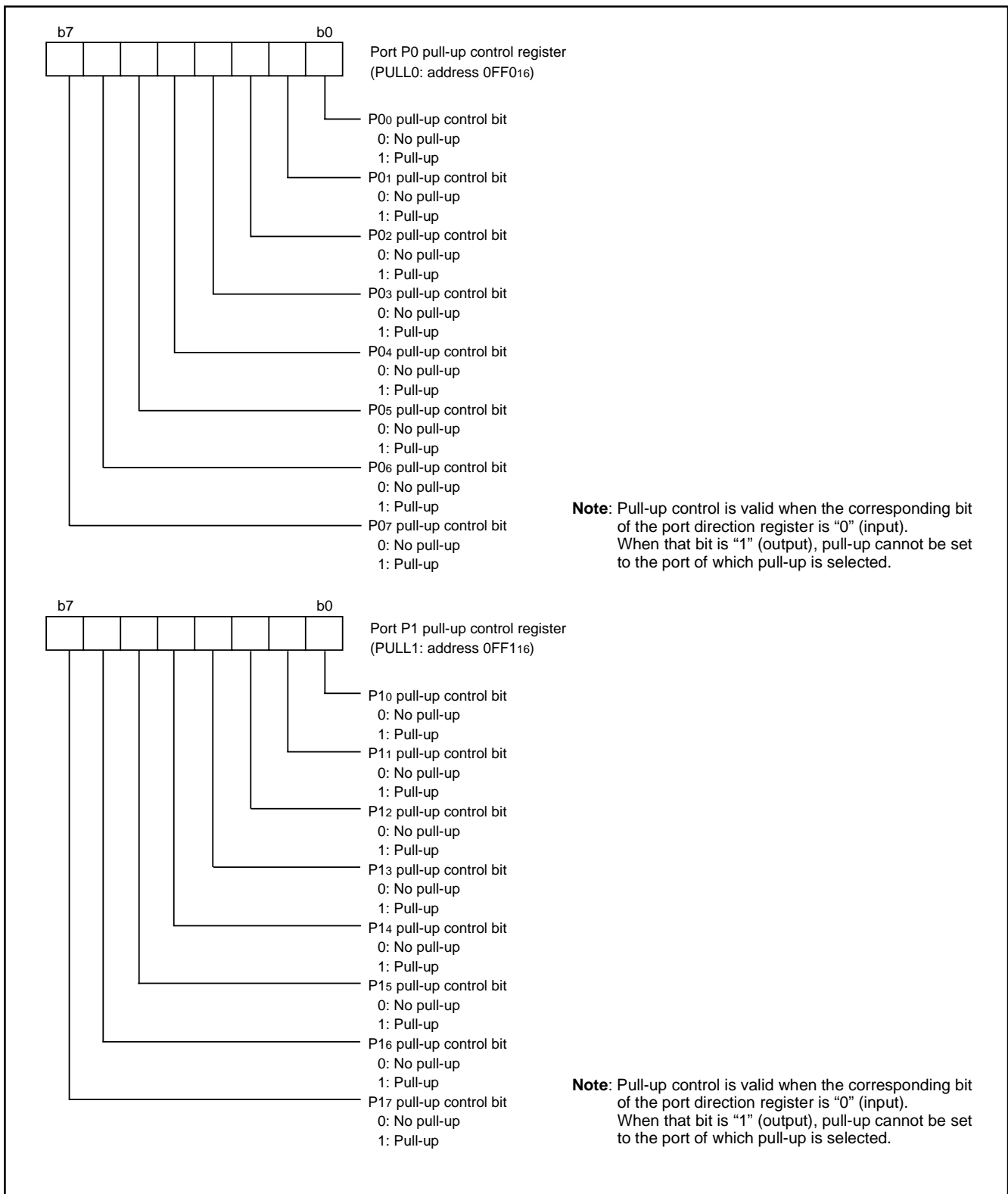

Fig. 16 Structure of port pull-up control register (1)

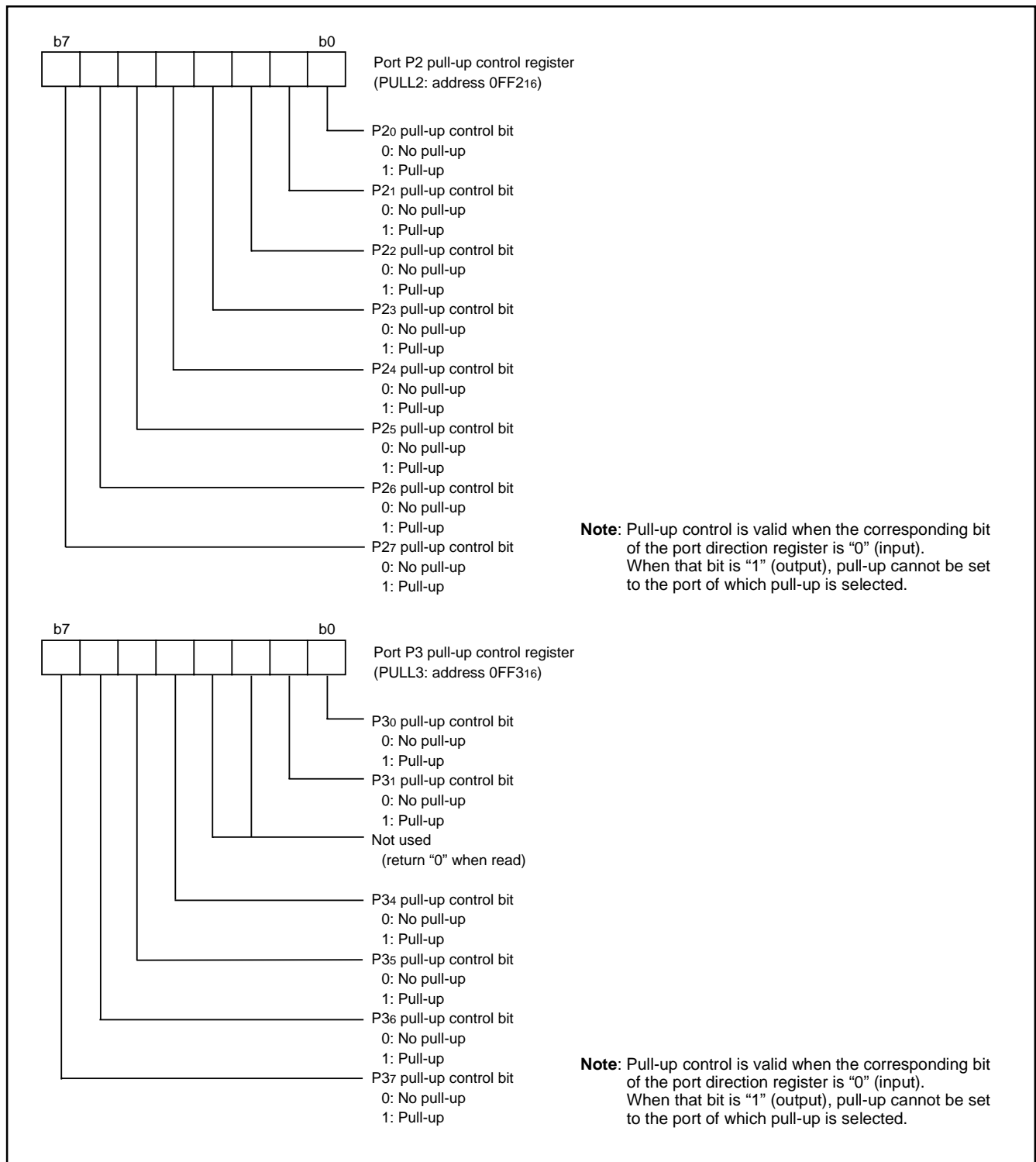

Fig. 17 Structure of port pull-up control register (2)

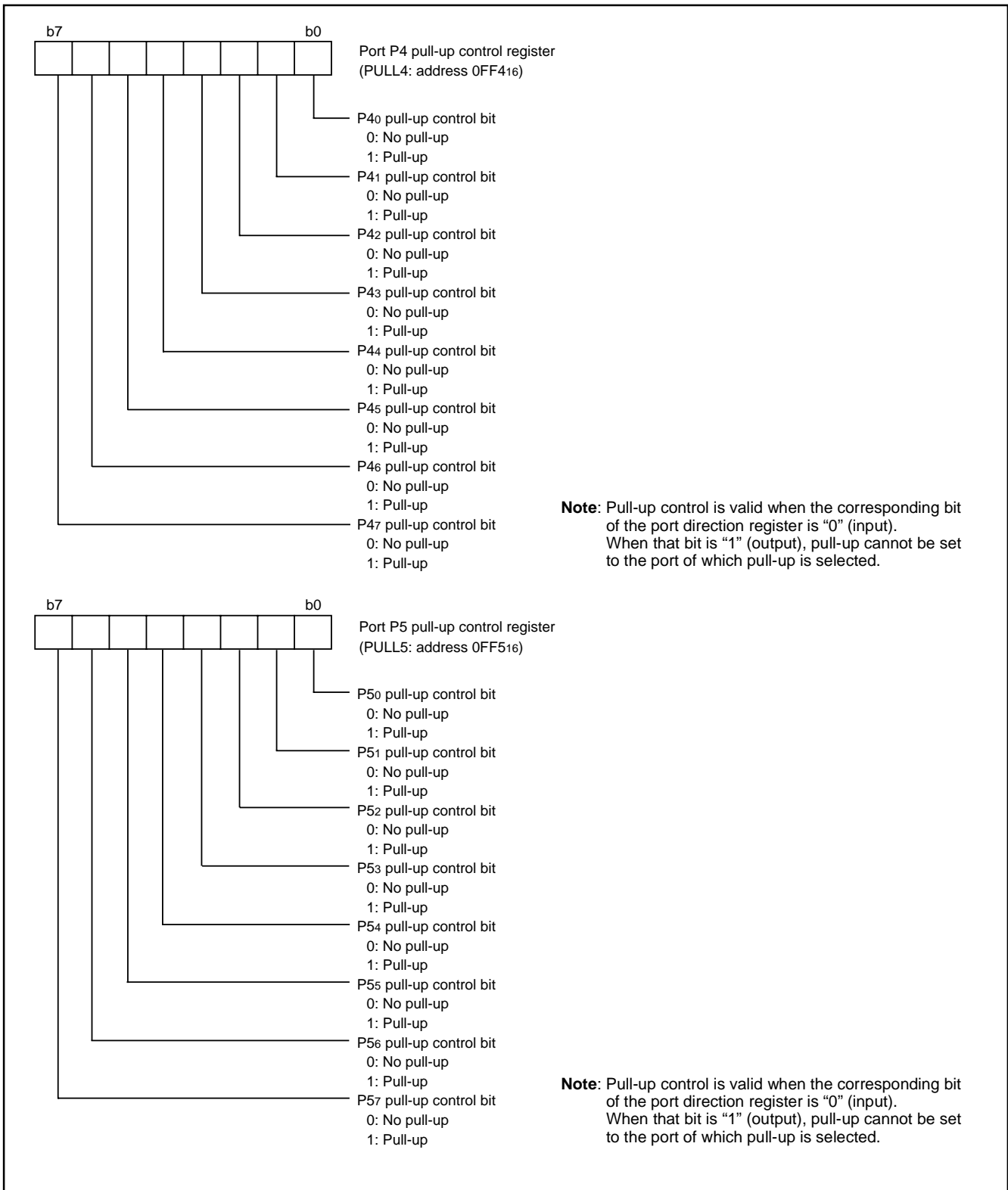

Fig. 18 Structure of port pull-up control register (3)

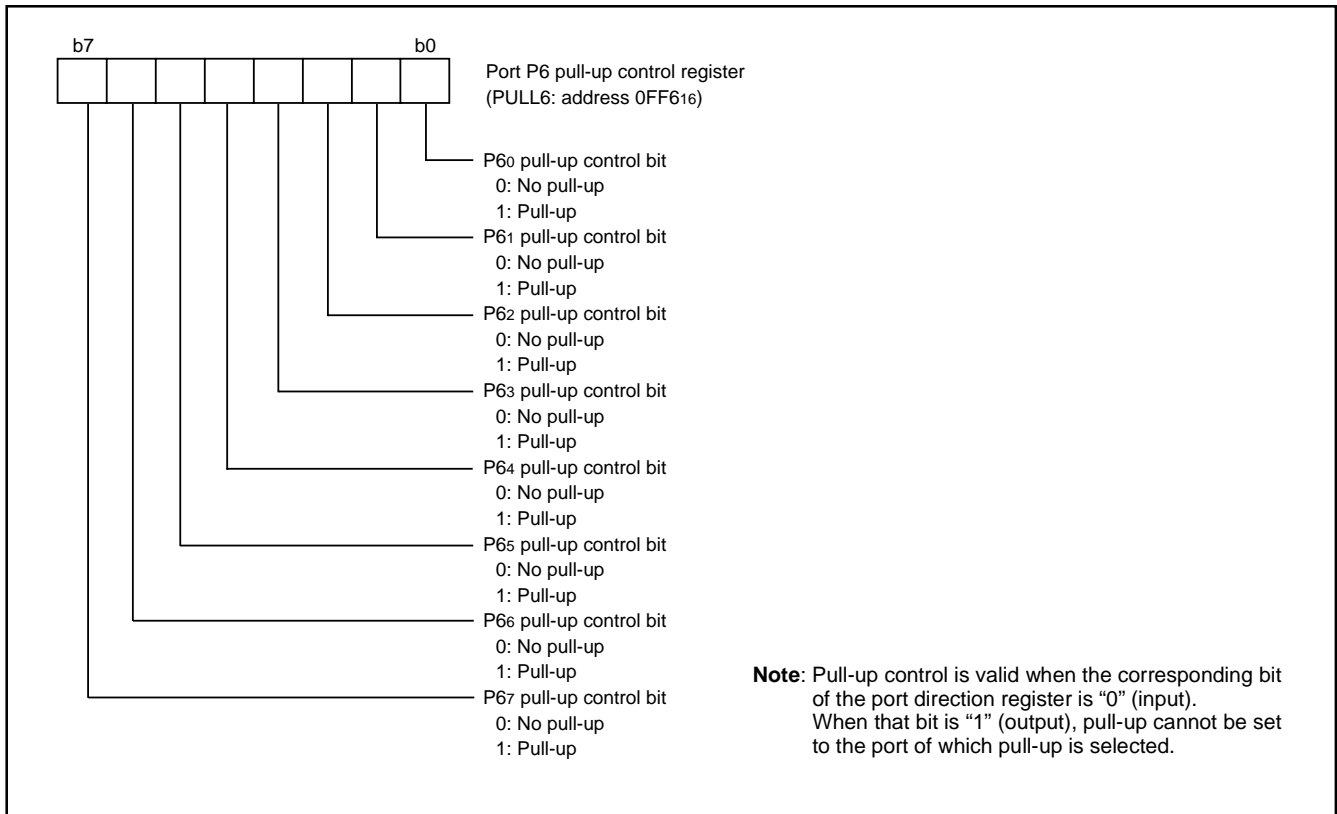

Fig. 19 Structure of port pull-up control register (4)



## INTERRUPTS

The 3803 group (Spec. H)'s interrupts are a type of vector and occur by 16 sources among 21 sources: eight external, twelve internal, and one software.

### Interrupt Control

Each interrupt is controlled by an interrupt request bit, an interrupt enable bit, and the interrupt disable flag except for the software interrupt set by the BRK instruction. An interrupt occurs if the corresponding interrupt request and enable bits are "1" and the interrupt disable flag is "0".

Interrupt enable bits can be set or cleared by software.

Interrupt request bits can be cleared by software, but cannot be set by software.

The reset and the BRK instruction cannot be disabled with any flag or bit. The I (interrupt disable) flag disables all interrupts except the reset and the BRK instruction interrupt.

When several interrupt requests occur at the same time, the interrupts are received according to priority.

### Interrupt Operation

By acceptance of an interrupt, the following operations are automatically performed:

1. The contents of the program counter and the processor status register are automatically pushed onto the stack.
2. The interrupt disable flag is set and the corresponding interrupt request bit is cleared.
3. The interrupt jump destination address is read from the vector table into the program counter.

### Interrupt Source Selection

Which of each combination of the following interrupt sources can be selected by the interrupt source selection register (address 003916).

1. INT0 or Timer Z
2. CNTR1 or Serial I/O3 reception
3. Serial I/O2 or Timer Z
7. INT4 or CNTR2
8. A-D converter or serial I/O3 transmission

### External Interrupt Pin Selection

The occurrence sources of the external interrupt INT0 and INT4 can be selected from either input from INT00 and INT40 pin, or input from INT01 and INT41 pin by the INT0, INT4 interrupt switch bit of interrupt edge selection register (bit 6 of address 003A16).

## ■ Notes

When setting the followings, the interrupt request bit may be set to "1".

- When setting external interrupt active edge

Related register: Interrupt edge selection register (address 003A16)  
Timer XY mode register (address 002316)  
Timer Z mode register (address 002A16)

- When switching interrupt sources of an interrupt vector address where two or more interrupt sources are allocated

Related register: Interrupt source selection register  
(address 003916)

When not requiring for the interrupt occurrence synchronized with these setting, take the following sequence.

- ① Set the corresponding interrupt enable bit to "0" (disabled).
- ② Set the interrupt edge select bit or the interrupt source select bit to "1".
- ③ Set the corresponding interrupt request bit to "0" after 1 or more instructions have been executed.
- ④ Set the corresponding interrupt enable bit to "1" (enabled).

Table 10 Interrupt vector addresses and priority

Interrupt Source	Priority	Vector Addresses (Note 1)		Interrupt Request Generating Conditions	Remarks
		High	Low		
Reset (Note 2)	1	FFFD <sub>16</sub>	FFFC <sub>16</sub>	At reset	Non-maskable
INT <sub>0</sub>	2	FFFB <sub>16</sub>	FFFA <sub>16</sub>	At detection of either rising or falling edge of INT <sub>0</sub> input	External interrupt (active edge selectable)
Timer Z				At timer Z underflow	
INT <sub>1</sub>	3	FFF9 <sub>16</sub>	FFF8 <sub>16</sub>	At detection of either rising or falling edge of INT <sub>1</sub> input	External interrupt (active edge selectable)
Serial I/O1 reception	4	FFF7 <sub>16</sub>	FFF6 <sub>16</sub>	At completion of serial I/O1 data reception	Valid when serial I/O1 is selected
Serial I/O1 transmission	5	FFF5 <sub>16</sub>	FFF4 <sub>16</sub>	At completion of serial I/O1 transmission shift or when transmission buffer is empty	Valid when serial I/O1 is selected
Timer X	6	FFF3 <sub>16</sub>	FFF2 <sub>16</sub>	At timer X underflow	
Timer Y	7	FFF1 <sub>16</sub>	FFF0 <sub>16</sub>	At timer Y underflow	
Timer 1	8	FFEF <sub>16</sub>	FFEE <sub>16</sub>	At timer 1 underflow	STP release timer underflow
Timer 2	9	FFED <sub>16</sub>	FFEC <sub>16</sub>	At timer 2 underflow	
CNTR <sub>0</sub>	10	FFE9 <sub>16</sub>	FFE8 <sub>16</sub>	At detection of either rising or falling edge of CNTR <sub>0</sub> input	External interrupt (active edge selectable)
Serial I/O3 reception				At completion of serial I/O3 data reception	Valid when serial I/O3 is selected
Serial I/O2	12	FFE7 <sub>16</sub>	FFE6 <sub>16</sub>	At completion of serial I/O2 data transmission or reception	Valid when serial I/O2 is selected
Timer Z				At timer Z underflow	
INT <sub>2</sub>	13	FFE5 <sub>16</sub>	FFE4 <sub>16</sub>	At detection of either rising or falling edge of INT <sub>2</sub> input	External interrupt (active edge selectable)
INT <sub>3</sub>	14	FFE3 <sub>16</sub>	FFE2 <sub>16</sub>	At detection of either rising or falling edge of INT <sub>3</sub> input	External interrupt (active edge selectable)
INT <sub>4</sub>	15	FFE1 <sub>16</sub>	FFE0 <sub>16</sub>	At detection of either rising or falling edge of INT <sub>4</sub> input	External interrupt (active edge selectable)
CNTR <sub>2</sub>				At detection of either rising or falling edge of CNTR <sub>2</sub> input	External interrupt (active edge selectable)
A-D converter	16	FFDF <sub>16</sub>	FFDE <sub>16</sub>	At completion of A-D conversion	
Serial I/O3 transmission				At completion of serial I/O3 transmission shift or when transmission buffer is empty	Valid when serial I/O3 is selected
BRK instruction	17	FFDD <sub>16</sub>	FFDC <sub>16</sub>	At BRK instruction execution	Non-maskable software interrupt

Notes 1: Vector addresses contain interrupt jump destination addresses.

2: Reset function in the same way as an interrupt with the highest priority.

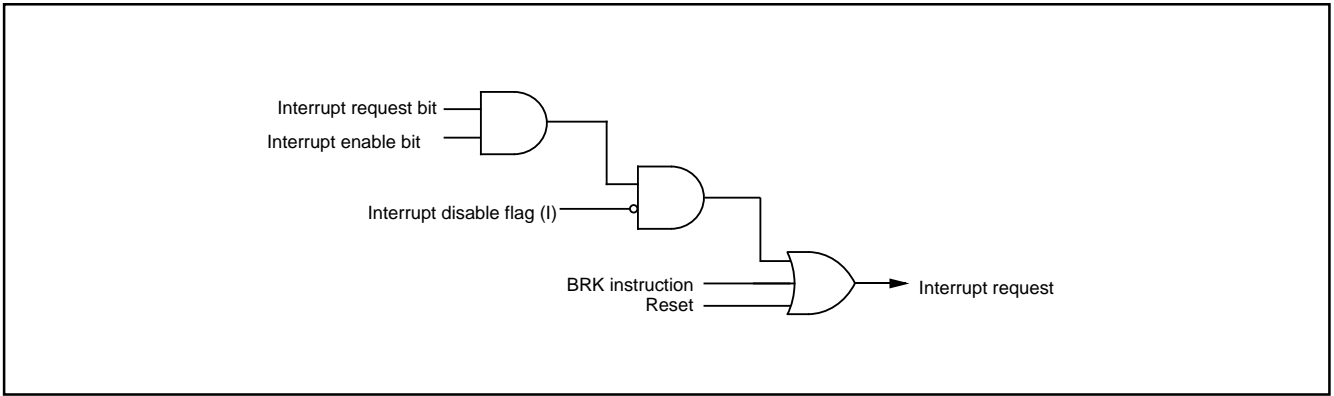

Fig. 20 Interrupt control

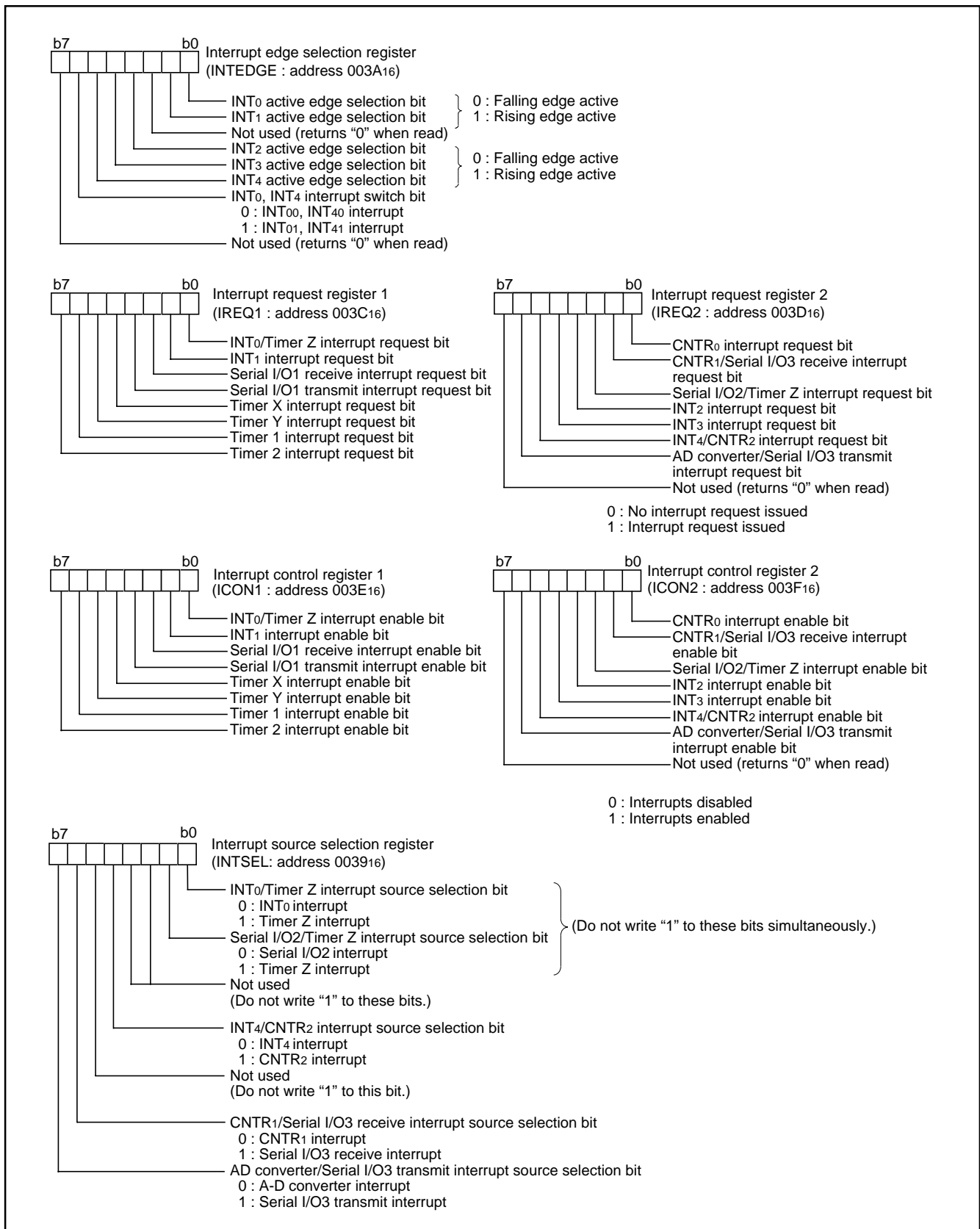

Fig. 21 Structure of interrupt-related registers

## TIMERS

### ●8-bit Timers

The 3803 group (Spec. H) has four 8-bit timers: timer 1, timer 2, timer X, and timer Y.

The timer 1 and timer 2 use one prescaler in common, and the timer X and timer Y use each prescaler. Those are 8-bit prescalers. Each of the timers and prescalers has a timer latch or a prescaler latch.

The division ratio of each timer or prescaler is given by  $1/(n + 1)$ , where  $n$  is the value in the corresponding timer or prescaler latch. All timers are down-counters. When the timer reaches "00<sub>16</sub>", an underflow occurs at the next count pulse and the contents of the corresponding timer latch are reloaded into the timer and the count is continued. When the timer underflows, the interrupt request bit corresponding to that timer is set to "1".

#### ●Timer divider

The divider count source is switched by the main clock division ratio selection bits of CPU mode register (bits 7 and 6 at address 003B<sub>16</sub>). When these bits are "00" (high-speed mode) or "01" (middle-speed mode), X<sub>IN</sub> is selected. When these bits are "10" (low-speed mode), X<sub>CIN</sub> is selected.

#### ●Prescaler 12

The prescaler 12 counts the output of the timer divider. The count source is selected by the timer 12, X count source selection register among 1/2, 1/4, 1/8, 1/16, 1/32, 1/64, 1/128, 1/256, 1/512, 1/1024 of  $f(X_{IN})$  or  $f(X_{CIN})$ .

### Timer 1 and Timer 2

The timer 1 and timer 2 counts the output of prescaler 12 and periodically set the interrupt request bit.

#### ●Prescaler X and prescaler Y

The prescaler X and prescaler Y count the output of the timer divider or  $f(X_{CIN})$ . The count source is selected by the timer 12, X count source selection register (address 000E<sub>16</sub>) and the timer Y, Z count source selection register (address 000F<sub>16</sub>) among 1/2, 1/4, 1/8, 1/16, 1/32, 1/64, 1/128, 1/256, 1/512, and 1/1024 of  $f(X_{IN})$  or  $f(X_{CIN})$ ; and  $f(X_{CIN})$ .

## Timer X and Timer Y

The timer X and timer Y can each select one of four operating modes by setting the timer XY mode register (address 0023<sub>16</sub>).

### (1) Timer mode

#### ●Mode selection

This mode can be selected by setting "00" to the timer X operating mode bits (bits 1 and 0) and the timer Y operating mode bits (bits 5 and 4) of the timer XY mode register (address 0023<sub>16</sub>).

#### ●Explanation of operation

The timer count operation is started by setting "0" to the timer X count stop bit (bit 3) and the timer Y count stop bit (bit 7) of the timer XY mode register (address 0023<sub>16</sub>).

When the timer reaches "00<sub>16</sub>", an underflow occurs at the next count pulse and the contents of timer latch are reloaded into the timer and the count is continued.

### (2) Pulse output mode

#### ●Mode selection

This mode can be selected by setting "01" to the timer X operating mode bits (bits 1 and 0) and the timer Y operating mode bits (bits 5 and 4) of the timer XY mode register (address 0023<sub>16</sub>).

#### ●Explanation of operation

The operation is the same as the timer mode's. Moreover the pulse which is inverted each time the timer underflows is output from CNTR<sub>0</sub>/CNTR<sub>1</sub> pin. Regardless of the timer counting or not the output of CNTR<sub>0</sub>/CNTR<sub>1</sub> pin is initialized to the level of specified by their active edge switch bits when writing to the timer. When the CNTR<sub>0</sub> active edge switch bit (bit 2) and the CNTR<sub>1</sub> active edge switch bit (bit 6) of the timer XY mode register (address 0023<sub>16</sub>) is "0", the output starts with "H" level. When it is "1", the output starts with "L" level.

Switching the CNTR<sub>0</sub> or CNTR<sub>1</sub> active edge switch bit will reverse the output level of the corresponding CNTR<sub>0</sub> or CNTR<sub>1</sub> pin.

#### ■Precautions

Set the double-function port of CNTR<sub>0</sub>/CNTR<sub>1</sub> pin and port P54/P55 to output in this mode.

### (3) Event counter mode

#### ●Mode selection

This mode can be selected by setting "10" to the timer X operating mode bits (bits 1 and 0) and the timer Y operating mode bits (bits 5 and 4) of the timer XY mode register (address 002316).

#### ●Explanation of operation

The operation is the same as the timer mode's except that the timer counts signals input from the CNTR0 or CNTR1 pin. The valid edge for the count operation depends on the CNTR0 active edge switch bit (bit 2) or the CNTR1 active edge switch bit (bit 6) of the timer XY mode register (address 002316). When it is "0", the rising edge is valid. When it is "1", the falling edge is valid.

#### ■Precautions

Set the double-function port of CNTR0/CNTR1 pin and port P54/P55 to input in this mode.

### (4) Pulse width measurement mode

#### ●Mode selection

This mode can be selected by setting "11" to the timer X operating mode bits (bits 1 and 0) and the timer Y operating mode bits (bits 5 and 4) of the timer XY mode register (address 002316).

#### ●Explanation of operation

When the CNTR0 active edge switch bit (bit 2) or the CNTR1 active edge switch bit (bit 6) of the timer XY mode register (address 002316) is "1", the timer counts during the term of one falling edge of CNTR0/CNTR1 pin input until the next rising edge of input ("L" term). When it is "0", the timer counts during the term of one rising edge input until the next falling edge input ("H" term).

#### ■Precautions

Set the double-function port of CNTR0/CNTR1 pin and port P54/P55 to input in this mode.

The count operation can be stopped by setting "1" to the timer X count stop bit (bit 3) and the timer Y count stop bit (bit 7) of the timer XY mode register (address 002316). The interrupt request bit is set to "1" each time the timer underflows.

#### ●Precautions when switching count source

When switching the count source by the timer 12, X and Y count source selection bits, the value of timer count is altered in considerable amount owing to generating of thin pulses on the count input signals.

Therefore, select the timer count source before setting the value to the prescaler and the timer.

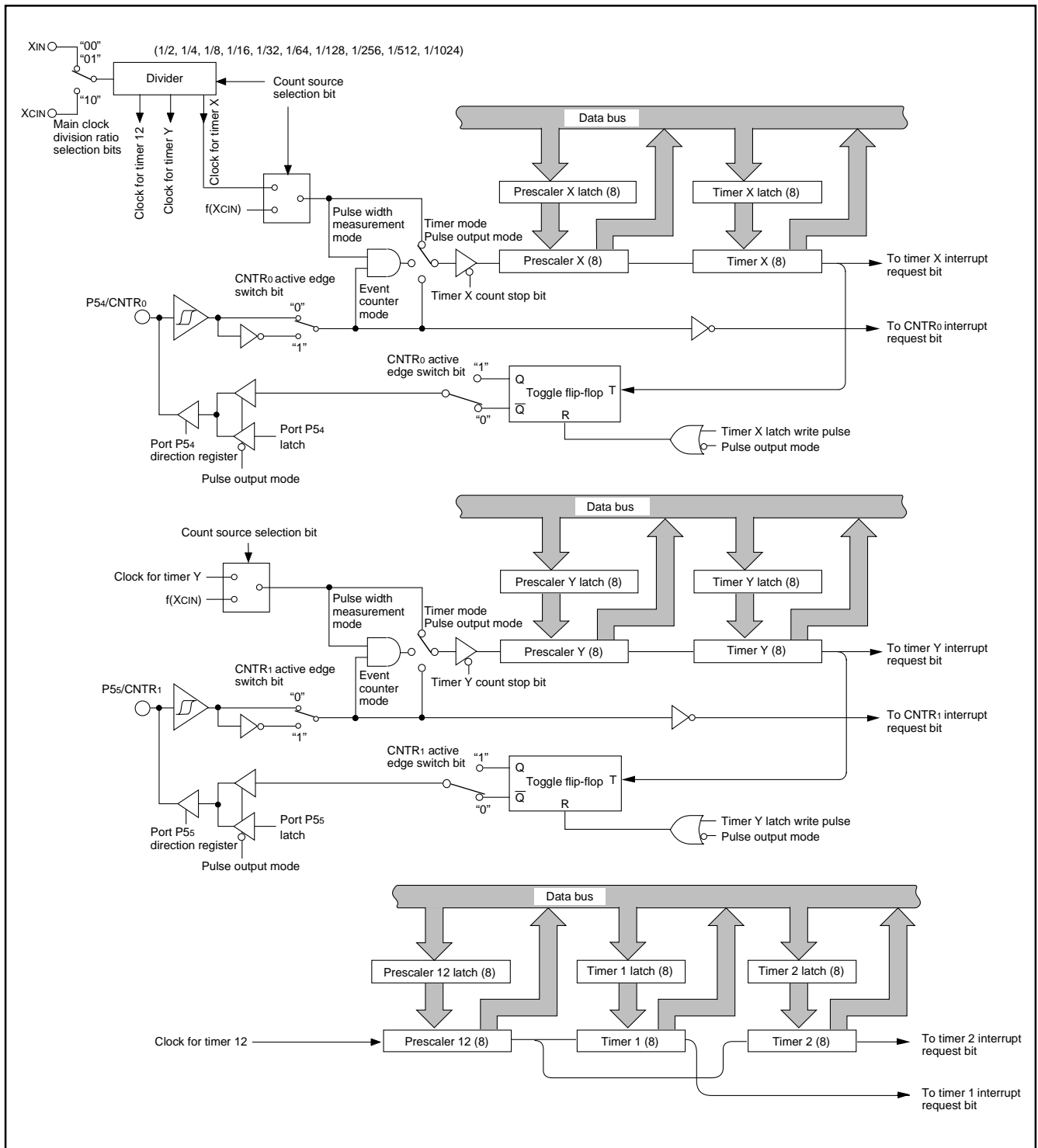

Fig. 22 Block diagram of timer X, timer Y, timer 1, and timer 2

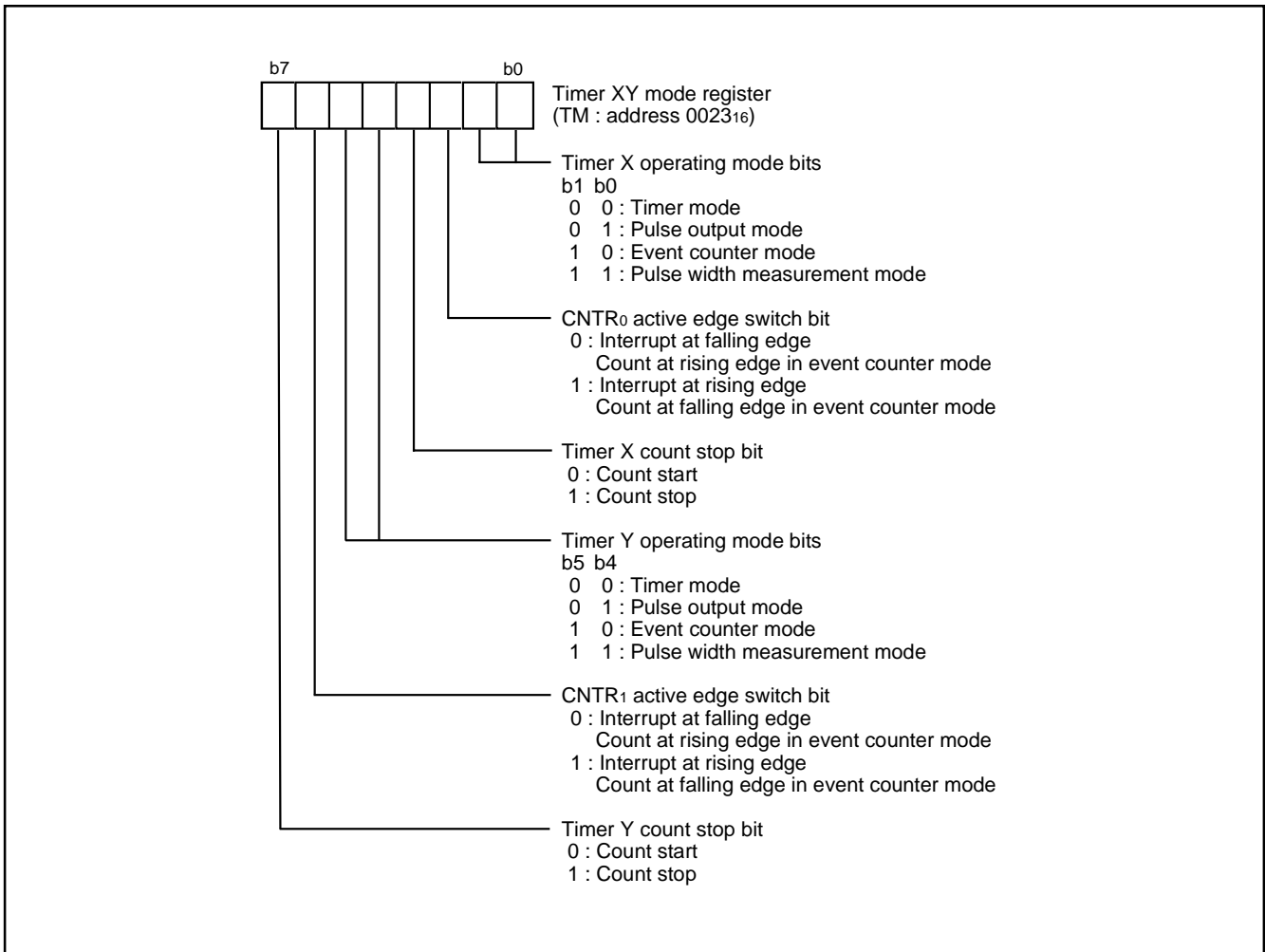

Fig. 23 Structure of timer XY mode register



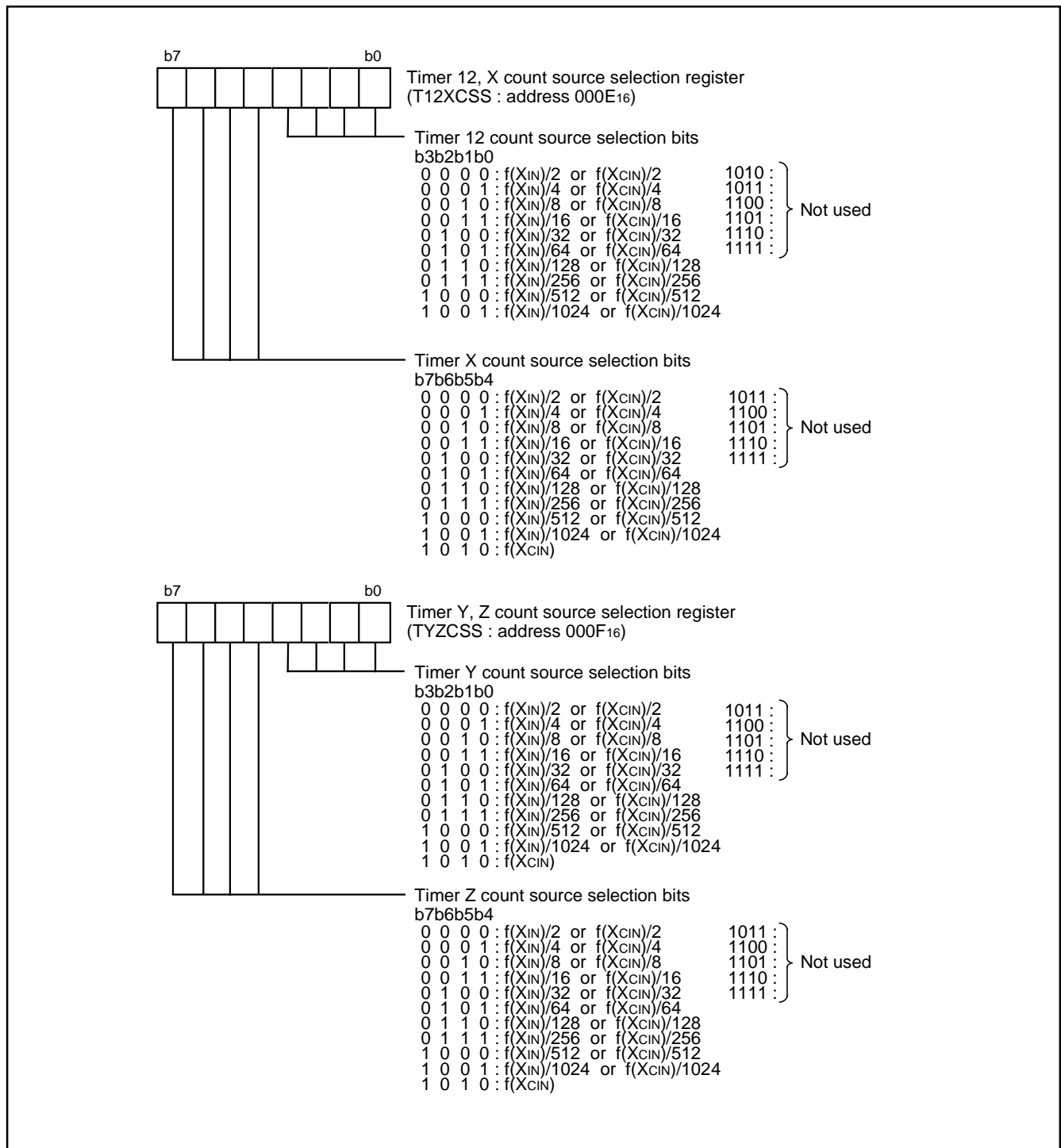

Fig. 24 Structure of timer 12, X and timer Y, Z count source selection registers

## ●16-bit Timer

The timer Z is a 16-bit timer. When the timer reaches "0000<sub>16</sub>", an underflow occurs at the next count pulse and the corresponding timer latch is reloaded into the timer and the count is continued. When the timer underflows, the interrupt request bit corresponding to the timer Z is set to "1".

When reading/writing to the timer Z, perform reading/writing to both the high-order byte and the low-order byte. When reading the timer Z, read from the high-order byte first, followed by the low-order byte. Do not perform the writing to the timer Z between read operation of the high-order byte and read operation of the low-order byte. When writing to the timer Z, write to the low-order byte first, followed by the high-order byte. Do not perform the reading to the timer Z between write operation of the low-order byte and write operation of the high-order byte.

The timer Z can select the count source by the timer Z count source selection bits of timer Y, Z count source selection register (bits 7 to 4 at address 000F<sub>16</sub>).

Timer Z can select one of seven operating modes by setting the timer Z mode register (address 002A<sub>16</sub>).

### (1) Timer mode

#### ●Mode selection

This mode can be selected by setting "000" to the timer Z operating mode bits (bits 2 to 0) and setting "0" to the timer/event counter mode switch bit (b7) of the timer Z mode register (address 002A<sub>16</sub>).

#### ●Count source selection

In high- or middle-speed mode, 1/2, 1/4, 1/8, 1/16, 1/32, 1/64, 1/128, 1/256, 1/512 or 1/1024 of f(XIN); or f(XCIN) can be selected as the count source.

In low-speed mode, 1/2, 1/4, 1/8, 1/16, 1/32, 1/64, 1/128, 1/256, 1/512 or 1/1024 of f(XCIN); or f(XCIN) can be selected as the count source.

#### ●Interrupt

When an underflow occurs, the INT0/timer Z interrupt request bit (bit 0) of the interrupt request register 1 (address 003C<sub>16</sub>) is set to "1".

#### ●Explanation of operation

During timer stop, usually write data to a latch and a timer at the same time to set the timer value.

The timer count operation is started by setting "0" to the timer Z count stop bit (bit 6) of the timer Z mode register (address 002A<sub>16</sub>).

When the timer reaches "0000<sub>16</sub>", an underflow occurs at the next count pulse and the contents of timer latch are reloaded into the timer and the count is continued.

When writing data to the timer during operation, the data is written only into the latch. Then the new latch value is reloaded into the timer at the next underflow.

### (2) Event counter mode

#### ●Mode selection

This mode can be selected by setting "000" to the timer Z operating mode bits (bits 2 to 0) and setting "1" to the timer/event counter mode switch bit (bit 7) of the timer Z mode register (address 002A<sub>16</sub>).

The valid edge for the count operation depends on the CNTR2 active edge switch bit (bit 5) of the timer Z mode register (address 002A<sub>16</sub>). When it is "0", the rising edge is valid. When it is "1", the falling edge is valid.

#### ●Interrupt

The interrupt at an underflow is the same as the timer mode's.

#### ●Explanation of operation

The operation is the same as the timer mode's.

Set the double-function port of CNTR2 pin and port P47 to input in this mode.

Figure 27 shows the timing chart of the timer/event counter mode.

### (3) Pulse output mode

#### ●Mode selection

This mode can be selected by setting "001" to the timer Z operating mode bits (bits 2 to 0) and setting "0" to the timer/event counter mode switch bit (b7) of the timer Z mode register (address 002A<sub>16</sub>).

#### ●Count source selection

In high- or middle-speed mode, 1/2, 1/4, 1/8, 1/16, 1/32, 1/64, 1/128, 1/256, 1/512 or 1/1024 of f(XIN); or f(XCIN) can be selected as the count source.

In low-speed mode, 1/2, 1/4, 1/8, 1/16, 1/32, 1/64, 1/128, 1/256, 1/512 or 1/1024 of f(XCIN); or f(XCIN) can be selected as the count source.

#### ●Interrupt

The interrupt at an underflow is the same as the timer mode's.

#### ●Explanation of operation

The operation is the same as the timer mode's. Moreover the pulse which is inverted each time the timer underflows is output from CNTR2 pin. When the CNTR2 active edge switch bit (bit 5) of the timer Z mode register (address 002A<sub>16</sub>) is "0", the output starts with "H" level. When it is "1", the output starts with "L" level.

#### ■Precautions

Set the double-function port of CNTR2 pin and port P47 to output in this mode.

The output from CNTR2 pin is initialized to the level depending on CNTR2 active edge switch bit by writing to the timer.

When the value of the CNTR2 active edge switch bit is changed, the output level of CNTR2 pin is inverted.

Figure 28 shows the timing chart of the pulse output mode.

## (4) Pulse period measurement mode

### ●Mode selection

This mode can be selected by setting "010" to the timer Z operating mode bits (bits 2 to 0) and setting "0" to the timer/event counter mode switch bit (b7) of the timer Z mode register (address 002A16).

### ●Count source selection

In high- or middle-speed mode, 1/2, 1/4, 1/8, 1/16, 1/32, 1/64, 1/128, 1/256, 1/512 or 1/1024 of  $f(X_{IN})$ ; or  $f(X_{CIN})$  can be selected as the count source.

In low-speed mode, 1/2, 1/4, 1/8, 1/16, 1/32, 1/64, 1/128, 1/256, 1/512 or 1/1024 of  $f(X_{CIN})$ ; or  $f(X_{CIN})$  can be selected as the count source.

### ●Interrupt

The interrupt at an underflow is the same as the timer mode's. When the pulse period measurement is completed, the INT4/CNTR2 interrupt request bit (bit 5) of the interrupt request register 2 (address 003D16) is set to "1".

### ●Explanation of operation

The cycle of the pulse which is input from the CNTR2 pin is measured. When the CNTR2 active edge switch bit (bit 5) of the timer Z mode register (address 002A16) is "0", the timer counts during the term from one falling edge of CNTR2 pin input to the next falling edge. When it is "1", the timer counts during the term from one rising edge input to the next rising edge input.

When the valid edge of measurement completion/start is detected, the 1's complement of the timer value is written to the timer latch and "FFFF16" is set to the timer.

Furthermore when the timer underflows, the timer Z interrupt request occurs and "FFFF16" is set to the timer. When reading the timer Z, the value of the timer latch (measured value) is read. The measured value is retained until the next measurement completion.

### ■Precautions

Set the double-function port of CNTR2 pin and port P47 to input in this mode.

A read-out of timer value is impossible in this mode. The timer can be written to only during timer stop (no measurement of pulse period).

Since the timer latch in this mode is specialized for the read-out of measured values, do not perform any write operation during measurement.

"FFFF16" is set to the timer when the timer underflows or when the valid edge of measurement start/completion is detected. Consequently, the timer value at start of pulse period measurement depends on the timer value just before measurement start.

Figure 29 shows the timing chart of the pulse period measurement mode.

## (5) Pulse width measurement mode

### ●Mode selection

This mode can be selected by setting "011" to the timer Z operating mode bits (bits 2 to 0) and setting "0" to the timer/event counter mode switch bit (b7) of the timer Z mode register (address 002A16).

### ●Count source selection

In high- or middle-speed mode, 1/2, 1/4, 1/8, 1/16, 1/32, 1/64, 1/128, 1/256, 1/512 or 1/1024 of  $f(X_{IN})$ ; or  $f(X_{CIN})$  can be selected as the count source.

In low-speed mode, 1/2, 1/4, 1/8, 1/16, 1/32, 1/64, 1/128, 1/256, 1/512 or 1/1024 of  $f(X_{CIN})$ ; or  $f(X_{CIN})$  can be selected as the count source.

### ●Interrupt

The interrupt at an underflow is the same as the timer mode's. When the pulse widths measurement is completed, the INT4/CNTR2 interrupt request bit (bit 5) of the interrupt request register 2 (address 003D16) is set to "1".

### ●Explanation of operation

The pulse width which is input from the CNTR2 pin is measured. When the CNTR2 active edge switch bit (bit 5) of the timer Z mode register (address 002A16) is "0", the timer counts during the term from one rising edge input to the next falling edge input ("H" term). When it is "1", the timer counts during the term from one falling edge of CNTR2 pin input to the next rising edge of input ("L" term). When the valid edge of measurement completion is detected, the 1's complement of the timer value is written to the timer latch.

When the valid edge of measurement completion/start is detected, "FFFF16" is set to the timer.

When the timer Z underflows, the timer Z interrupt occurs and "FFFF16" is set to the timer Z. When reading the timer Z, the value of the timer latch (measured value) is read. The measured value is retained until the next measurement completion.

### ■Precautions

Set the double-function port of CNTR2 pin and port P47 to input in this mode.

A read-out of timer value is impossible in this mode. The timer can be written to only during timer stop (no measurement of pulse widths).

Since the timer latch in this mode is specialized for the read-out of measured values, do not perform any write operation during measurement.

"FFFF16" is set to the timer when the timer underflows or when the valid edge of measurement start/completion is detected. Consequently, the timer value at start of pulse width measurement depends on the timer value just before measurement start.

Figure 30 shows the timing chart of the pulse width measurement mode.

## (6) Programmable waveform generating mode

### ●Mode selection

This mode can be selected by setting "100" to the timer Z operating mode bits (bits 2 to 0) and setting "0" to the timer/event counter mode switch bit (b7) of the timer Z mode register (address 002A16).

### ●Count source selection

In high- or middle-speed mode, 1/2, 1/4, 1/8, 1/16, 1/32, 1/64, 1/128, 1/256, 1/512 or 1/1024 of  $f(XIN)$ ; or  $f(XCIN)$  can be selected as the count source.

In low-speed mode, 1/2, 1/4, 1/8, 1/16, 1/32, 1/64, 1/128, 1/256, 1/512 or 1/1024 of  $f(XCIN)$ ; or  $f(XCIN)$  can be selected as the count source.

### ●Interrupt

The interrupt at an underflow is the same as the timer mode's.

### ●Explanation of operation

The operation is the same as the timer mode's. Moreover the timer outputs the data set in the output level latch (bit 4) of the timer Z mode register (address 002A16) from the CNTR2 pin each time the timer underflows.

Changing the value of the output level latch and the timer latch after an underflow makes it possible to output an optional waveform from the CNTR2 pin.

### ■Precautions

Set the double-function port of CNTR2 pin and port P47 to output in this mode.

Figure 31 shows the timing chart of the programmable waveform generating mode.

## (7) Programmable one-shot generating mode

### ●Mode selection

This mode can be selected by setting "101" to the timer Z operating mode bits (bits 2 to 0) and setting "0" to the timer/event counter mode switch bit (b7) of the timer Z mode register (address 002A16).

### ●Count source selection

In high- or middle-speed mode, 1/2, 1/4, 1/8, 1/16, 1/32, 1/64, 1/128, 1/256, 1/512 or 1/1024 of  $f(XIN)$ ; or  $f(XCIN)$  can be selected as the count source.

### ●Interrupt

The interrupt at an underflow is the same as the timer mode's.

The trigger to generate one-shot pulse can be selected by the INT1 active edge selection bit (bit 1) of the interrupt edge selection register (address 003A16). When it is "0", the falling edge active is selected; when it is "1", the rising edge active is selected.

When the valid edge of the INT1 pin is detected, the INT1 interrupt request bit (bit 1) of the interrupt request register 1 (address 003C16) is set to "1".

### ●Explanation of operation

•"H" one-shot pulse; Bit 5 of timer Z mode register = "0"

The output level of the CNTR2 pin is initialized to "L" at mode selection. When trigger generation (input signal to INT1 pin) is detected, "H" is output from the CNTR2 pin. When an underflow occurs, "L" is output. The "H" one-shot pulse width is set by the setting value to the timer Z register low-order and high-order. When trigger generating is detected during timer count stop, al-

though "H" is output from the CNTR2 pin, "H" output state continues because an underflow does not occur.

•"L" one-shot pulse; Bit 5 of timer Z mode register = "1"

The output level of the CNTR2 pin is initialized to "H" at mode selection. When trigger generation (input signal to INT1 pin) is detected, "L" is output from the CNTR2 pin. When an underflow occurs, "H" is output. The "L" one-shot pulse width is set by the setting value to the timer Z low-order and high-order. When trigger generating is detected during timer count stop, although "L" is output from the CNTR2 pin, "L" output state continues because an underflow does not occur.

### ■Precautions

Set the double-function port of CNTR2 pin and port P47 to output, and of INT1 pin and port P42 to input in this mode.

This mode cannot be used in low-speed mode.

If the value of the CNTR2 active edge switch bit is changed during one-shot generating enabled or generating one-shot pulse, then the output level from CNTR2 pin changes.

Figure 32 shows the timing chart of the programmable one-shot generating mode.

## ■Notes regarding all modes

### ●Timer Z write control

Which write control can be selected by the timer Z write control bit (bit 3) of the timer Z mode register (address 002A16), writing data to both the latch and the timer at the same time or writing data only to the latch.

When the operation "writing data only to the latch" is selected, the value is set to the timer latch by writing data to the address of timer Z and the timer is updated at next underflow. After reset release, the operation "writing data to both the latch and the timer at the same time" is selected, and the value is set to both the latch and the timer at the same time by writing data to the address of timer Z.

In the case of writing data only to the latch, if writing data to the latch and an underflow are performed almost at the same time, the timer value may become undefined.

### ●Timer Z read control

A read-out of timer value is impossible in pulse period measurement mode and pulse width measurement mode. In the other modes, a read-out of timer value is possible regardless of count operating or stopped.

However, a read-out of timer latch value is impossible.

### ●Switch of interrupt active edge of CNTR2 and INT1

Each interrupt active edge depends on setting of the CNTR2 active edge switch bit and the INT1 active edge selection bit.

### ●Switch of count source

When switching the count source by the timer Z count source selection bits, the value of timer count is altered in inconsiderable amount owing to generating of thin pulses on the count input signals.

Therefore, select the timer count source before setting the value to the prescaler and the timer.

### ●Usage of CNTR2 pin as normal I/O port

To use the CNTR2 pin as normal I/O port P47, set timer Z operating mode bits (b2, b1, b0) of timer Z mode register (address 002A16) to "000".

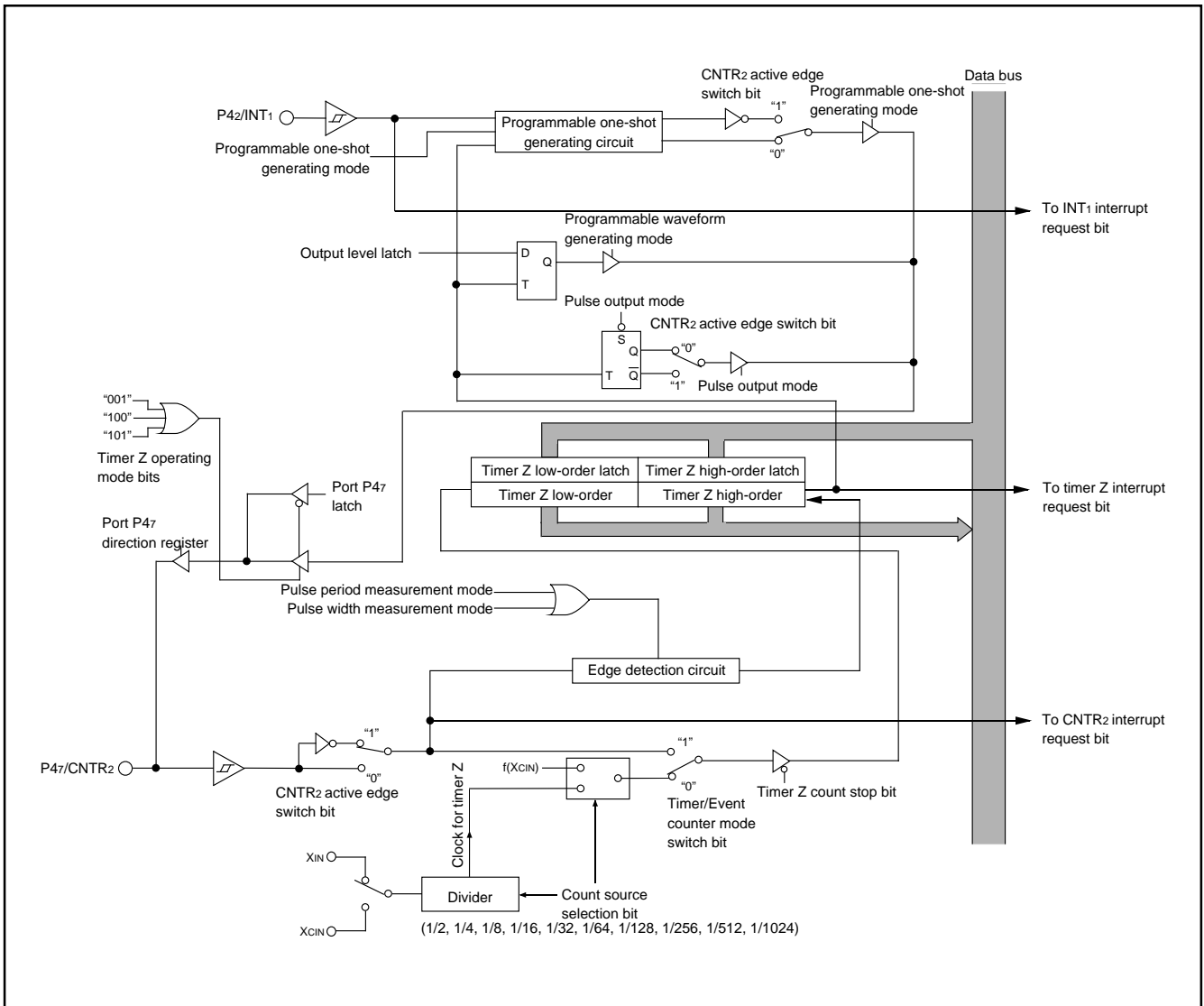

Fig. 25 Block diagram of timer Z

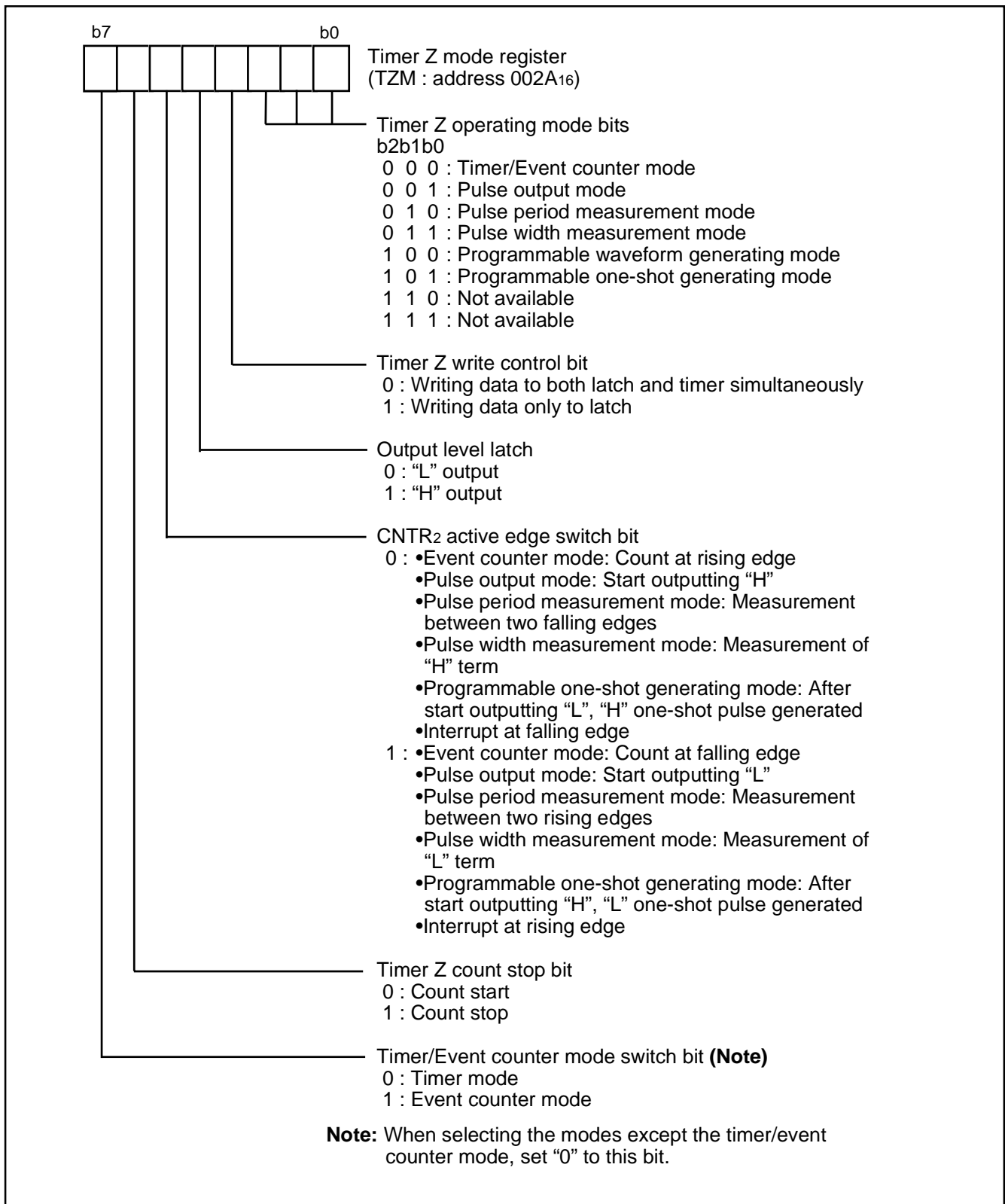

Fig. 26 Structure of timer Z mode register

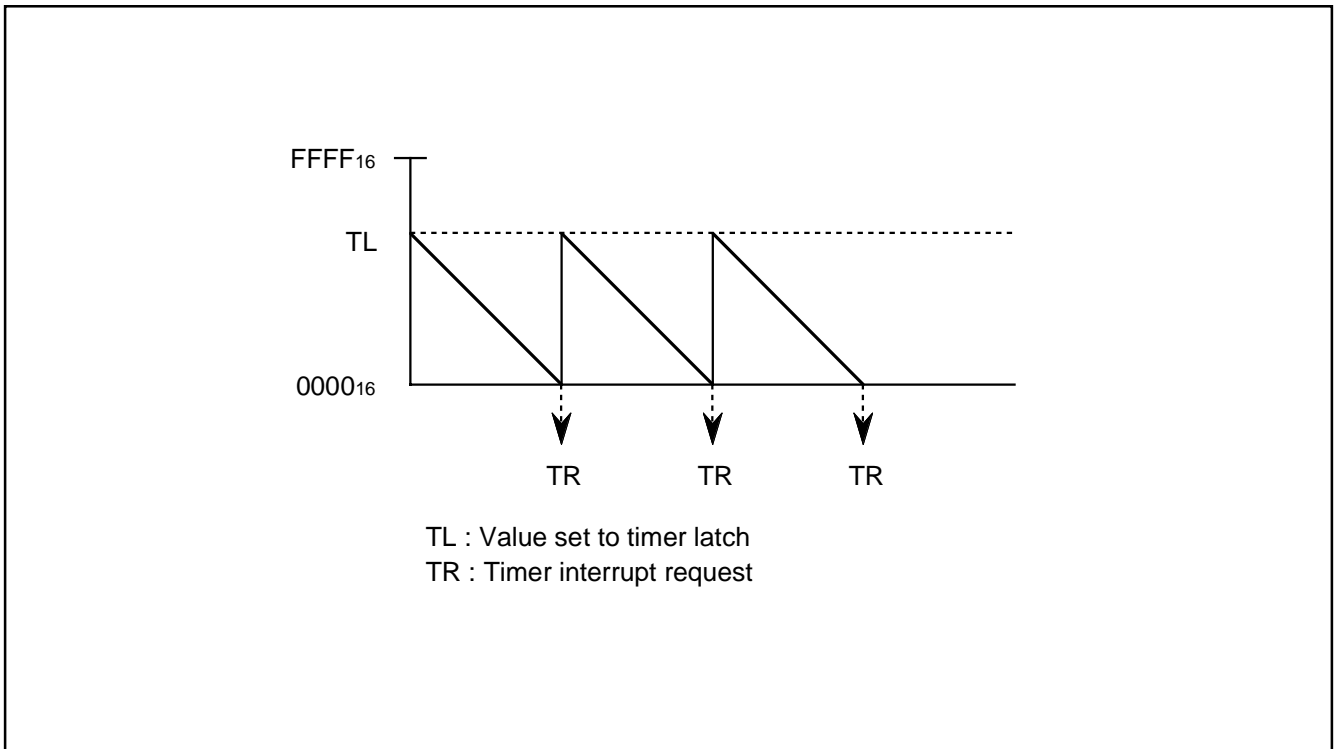

Fig. 27 Timing chart of timer/event counter mode

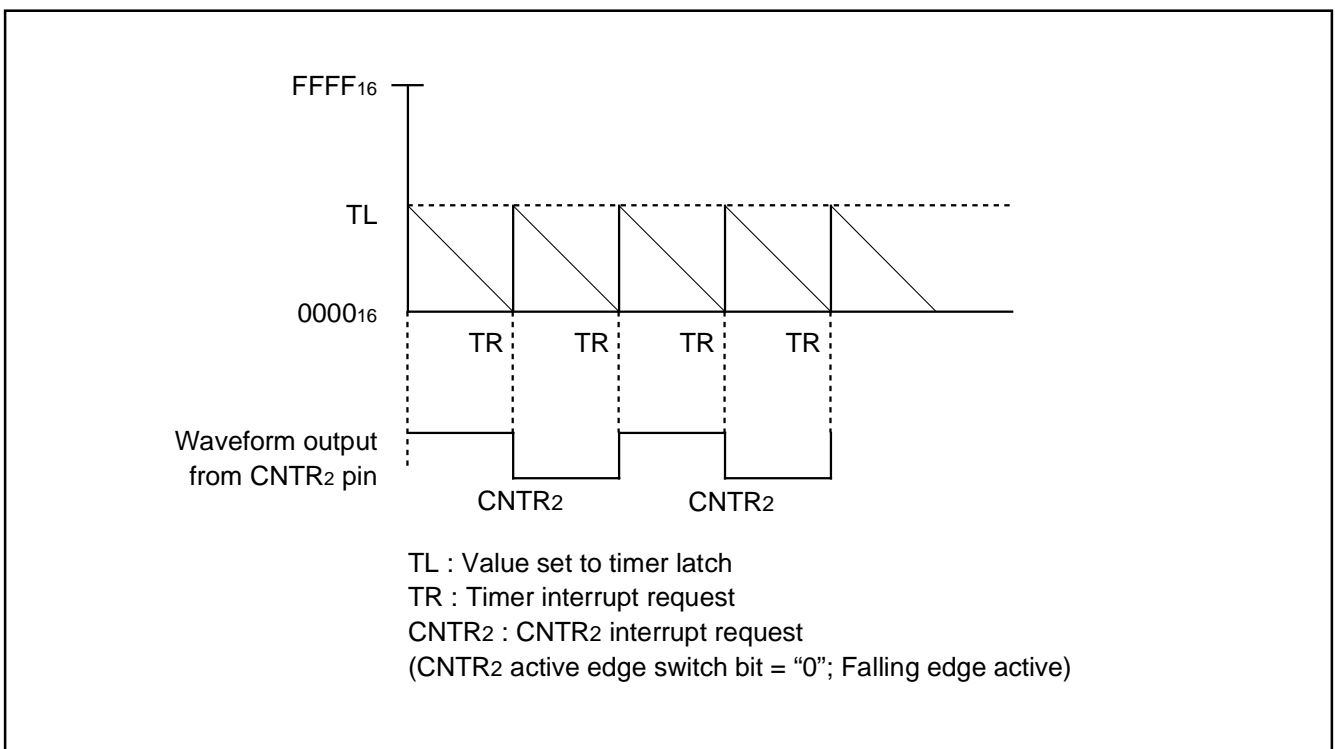

Fig. 28 Timing chart of pulse output mode

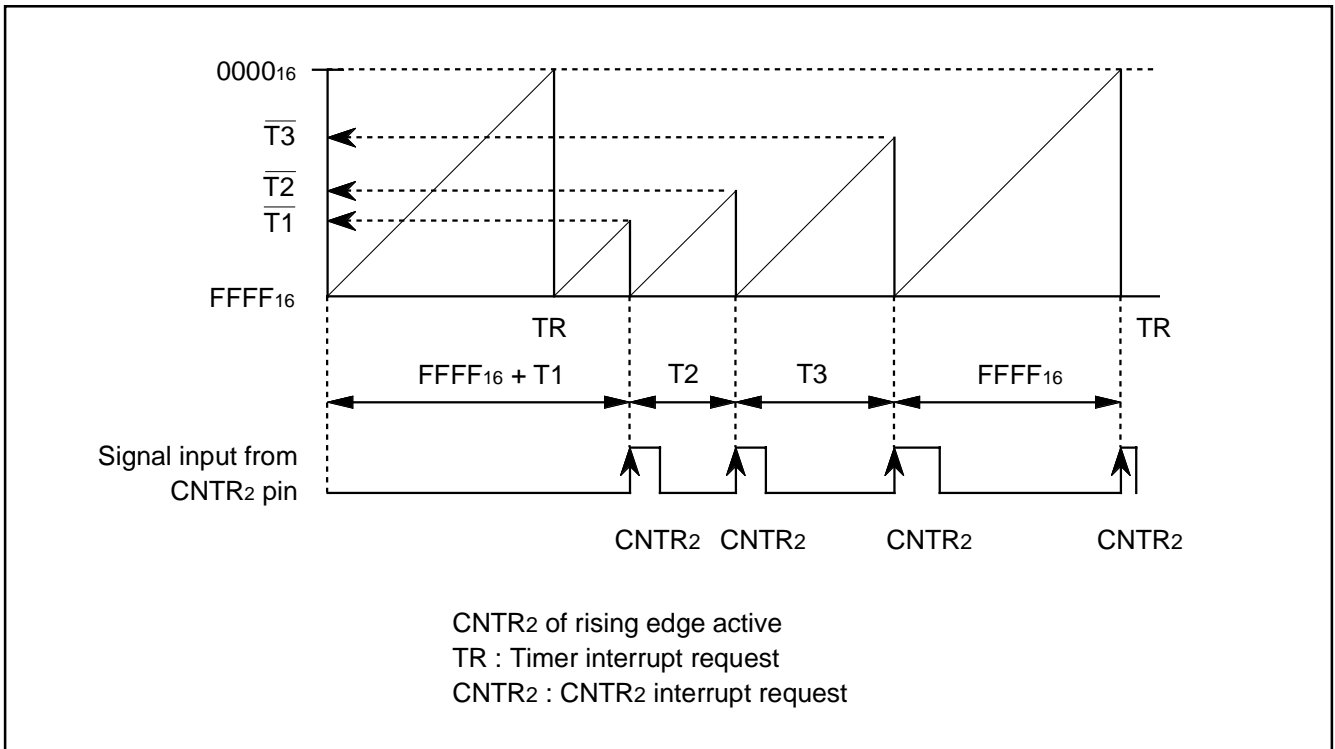

Fig. 29 Timing chart of pulse period measurement mode (Measuring term between two rising edges)

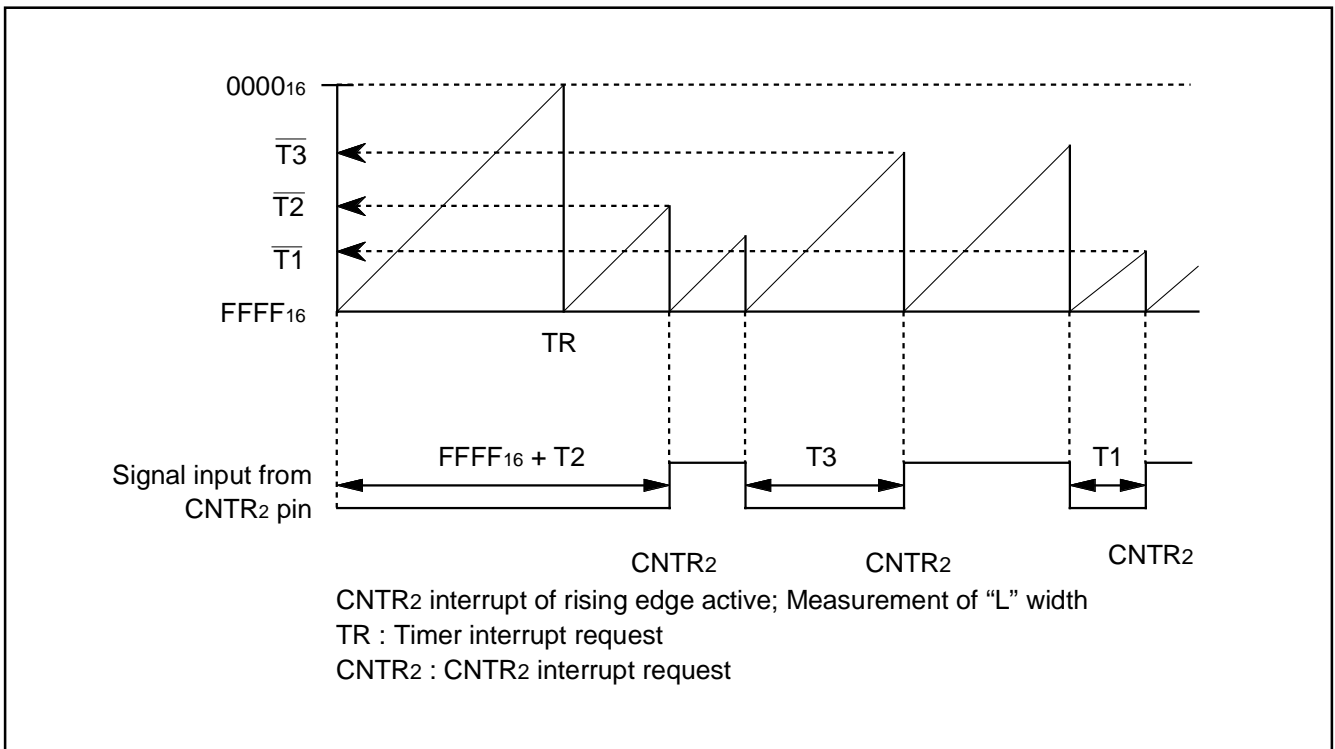

Fig. 30 Timing chart of pulse width measurement mode (Measuring "L" term)



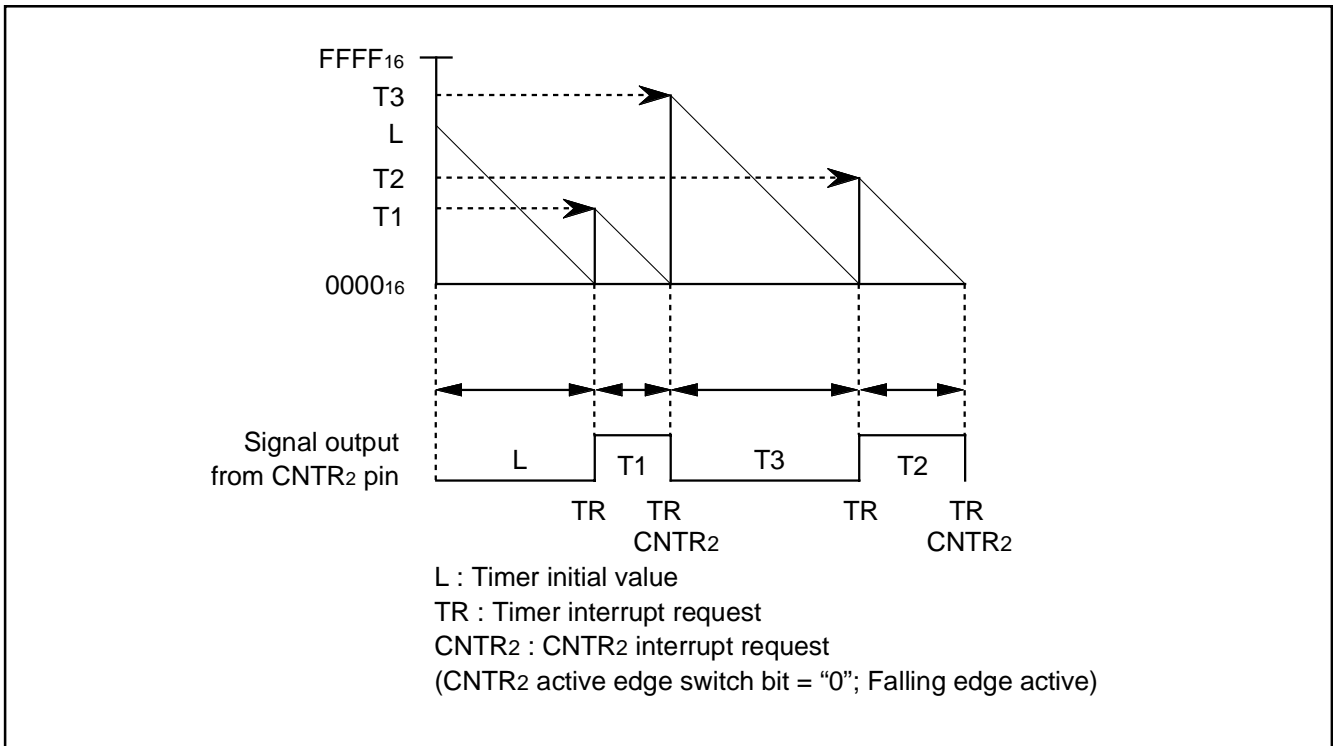

Fig. 31 Timing chart of programmable waveform generating mode

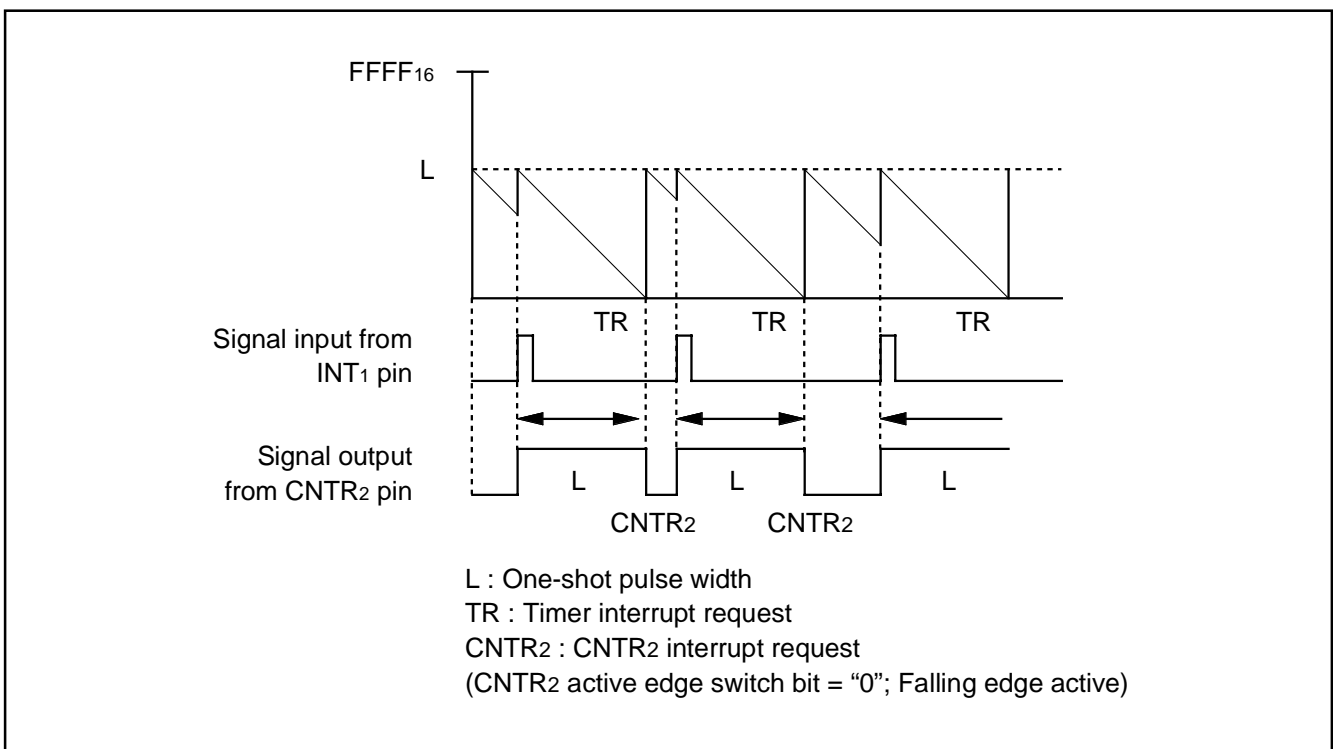

Fig. 32 Timing chart of programmable one-shot generating mode ("H" one-shot pulse generating)

**SERIAL I/O**  
**Serial I/O1**

Serial I/O1 can be used as either clock synchronous or asynchronous (UART) serial I/O. A dedicated timer is also provided for baud rate generation.

**(1) Clock Synchronous Serial I/O Mode**

Clock synchronous serial I/O1 mode can be selected by setting the serial I/O1 mode selection bit of the serial I/O1 control register (bit 6 of address 001A16) to "1".

For clock synchronous serial I/O, the transmitter and the receiver must use the same clock. If an internal clock is used, transfer is started by a write signal to the transmit/receive buffer register.

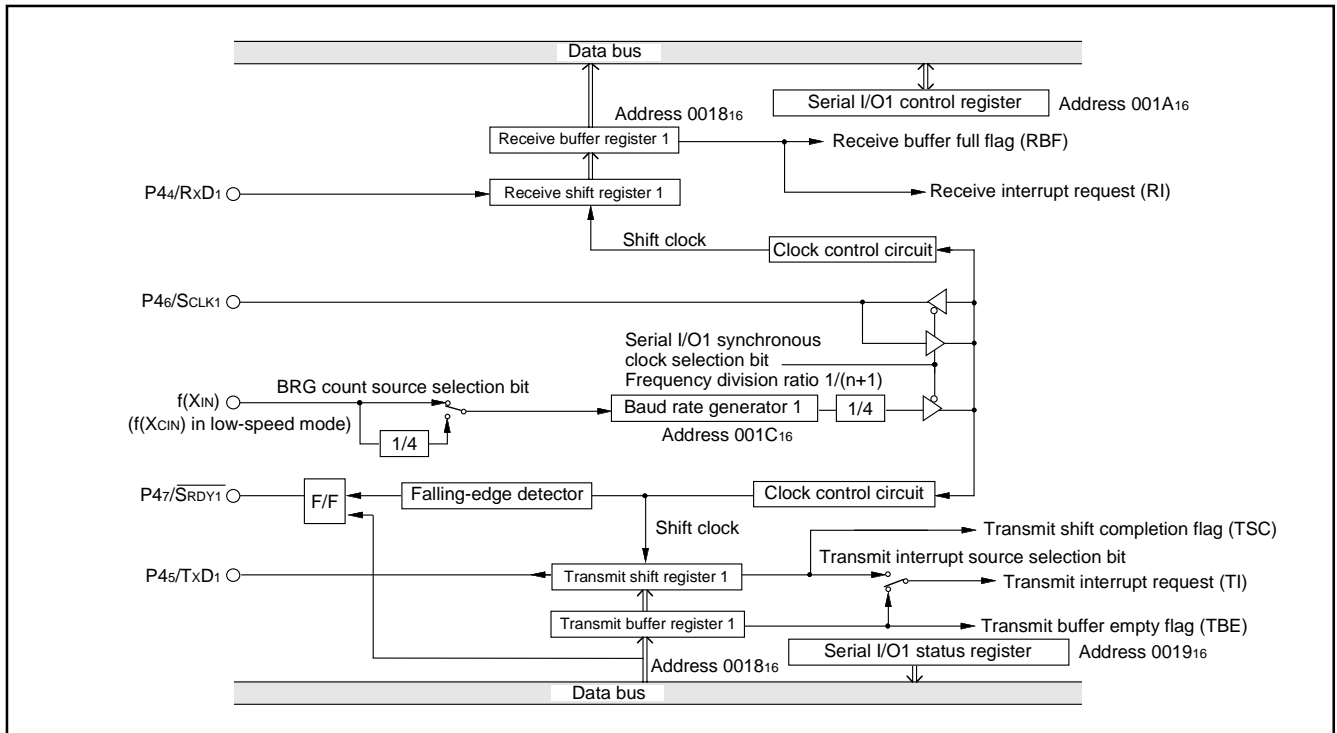

Fig. 33 Block diagram of clock synchronous serial I/O1

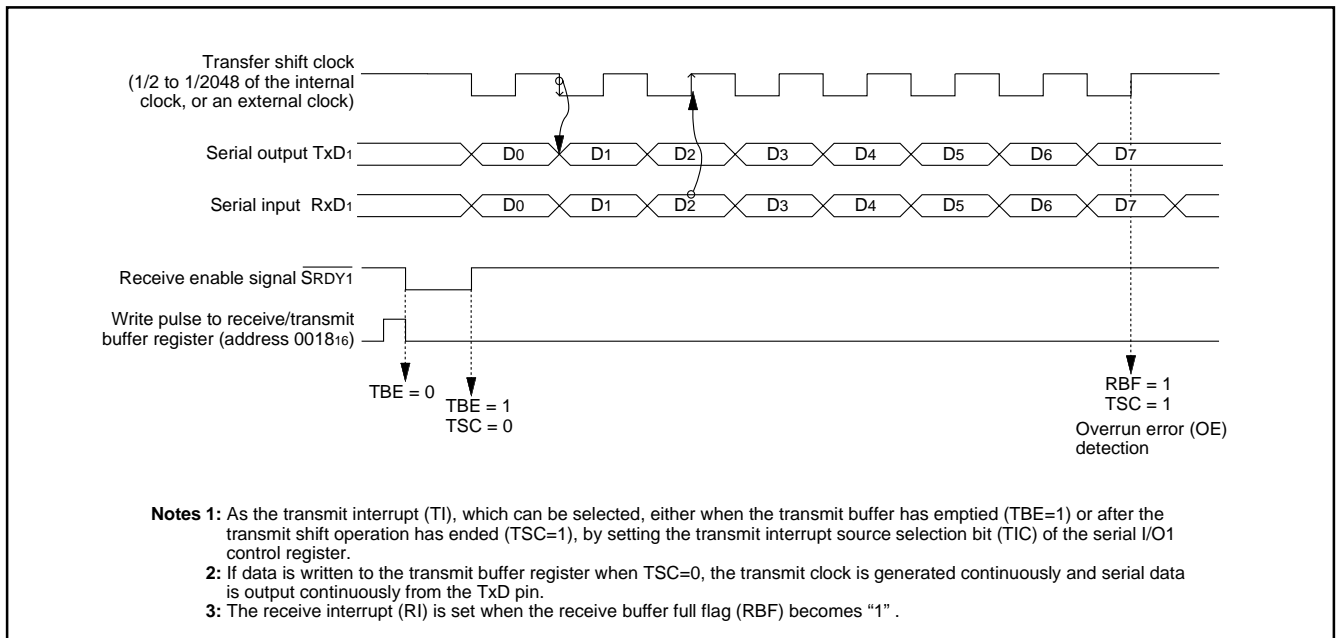

Fig. 34 Operation of clock synchronous serial I/O1

## (2) Asynchronous Serial I/O (UART) Mode

Clock asynchronous serial I/O mode (UART) can be selected by clearing the serial I/O1 mode selection bit of the serial I/O1 control register to "0".

Eight serial data transfer formats can be selected, and the transfer formats used by a transmitter and receiver must be identical.

The transmit and receive shift registers each have a buffer, but the

two buffers have the same address in a memory. Since the shift register cannot be written to or read from directly, transmit data is written to the transmit buffer register, and receive data is read from the receive buffer register.

The transmit buffer register can also hold the next data to be transmitted, and the receive buffer register can hold a character while the next character is being received.

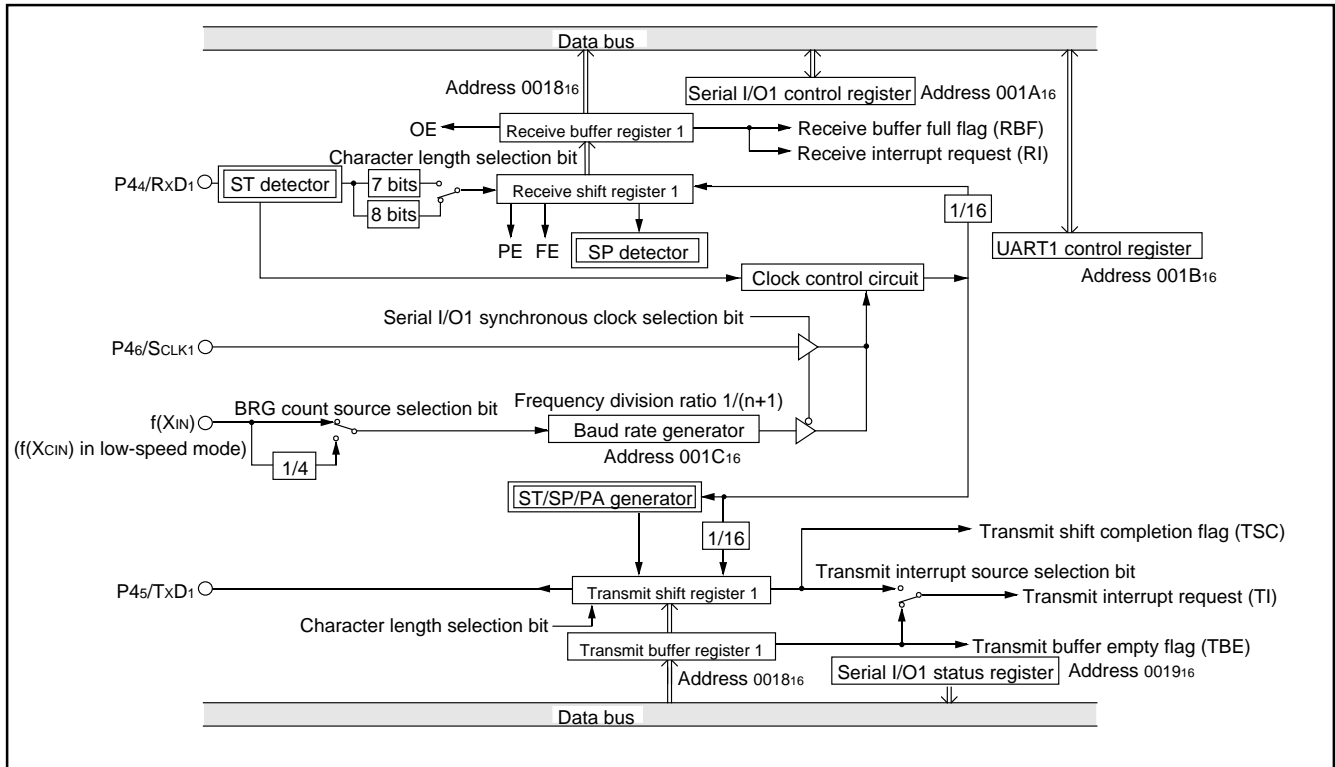

Fig. 35 Block diagram of UART serial I/O1

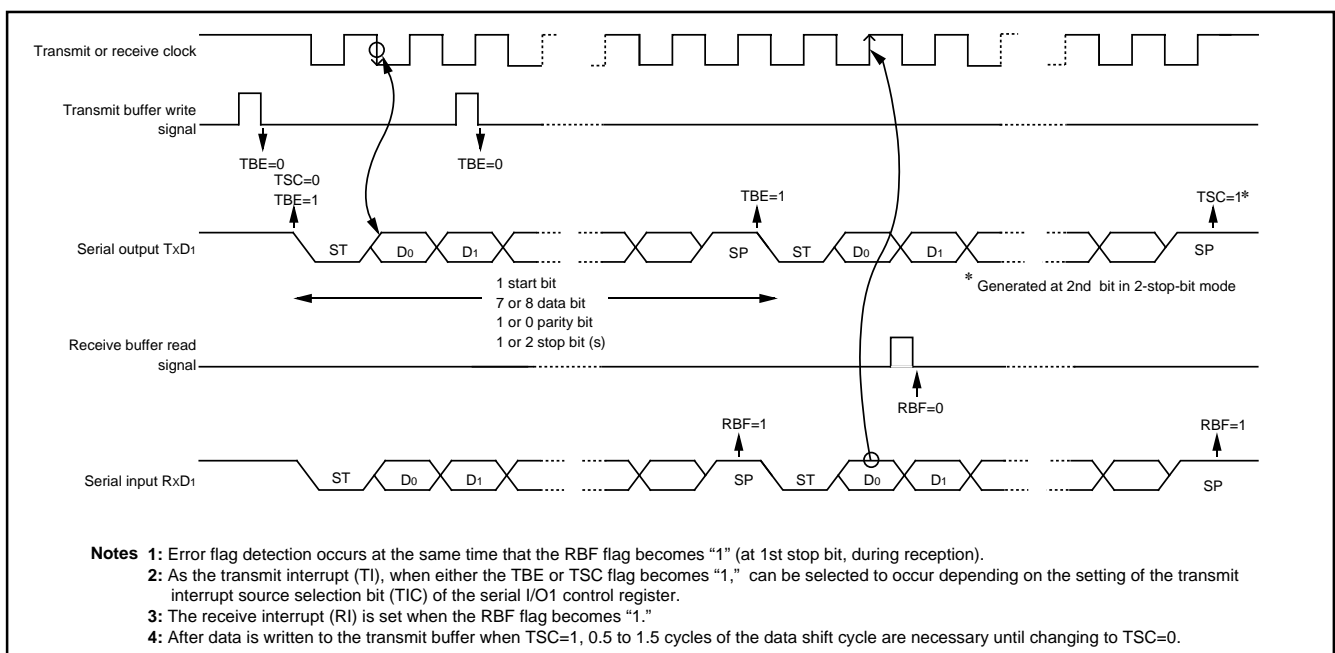

Fig. 36 Operation of UART serial I/O1

**[Serial I/O1 Control Register (SIO1CON)]**  
**001A16**

The serial I/O1 control register consists of eight control bits for the serial I/O1 function.

**[UART1 Control Register (UART1CON)]**  
**001B16**

The UART control register consists of four control bits (bits 0 to 3) which are valid when asynchronous serial I/O is selected and set the data format of an data transfer, and one bit (bit 4) which is always valid and sets the output structure of the P45/TxD1 pin.

**[Serial I/O1 Status Register (SIO1STS)]**  
**001916**

The read-only serial I/O1 status register consists of seven flags (bits 0 to 6) which indicate the operating status of the serial I/O1 function and various errors.

Three of the flags (bits 4 to 6) are valid only in UART mode.

The receive buffer full flag (bit 1) is cleared to "0" when the receive buffer register is read.

If there is an error, it is detected at the same time that data is transferred from the receive shift register to the receive buffer register, and the receive buffer full flag is set. A write to the serial I/O1 status register clears all the error flags OE, PE, FE, and SE (bit 3 to bit 6, respectively). Writing "0" to the serial I/O1 enable bit SIOE (bit 7 of the serial I/O1 control register) also clears all the status flags, including the error flags.

Bits 0 to 6 of the serial I/O1 status register are initialized to "0" at reset, but if the transmit enable bit (bit 4) of the serial I/O1 control register has been set to "1", the transmit shift completion flag (bit 2) and the transmit buffer empty flag (bit 0) become "1".

**[Transmit Buffer Register 1/Receive Buffer Register 1 (TB1/RB1)]** 001816

The transmit buffer register 1 and the receive buffer register 1 are located at the same address. The transmit buffer is write-only and the receive buffer is read-only. If a character bit length is 7 bits, the MSB of data stored in the receive buffer is "0".

**[Baud Rate Generator 1 (BRG1)]** 001C16

The baud rate generator determines the baud rate for serial transfer.

The baud rate generator divides the frequency of the count source by  $1/(n + 1)$ , where n is the value written to the baud rate generator.

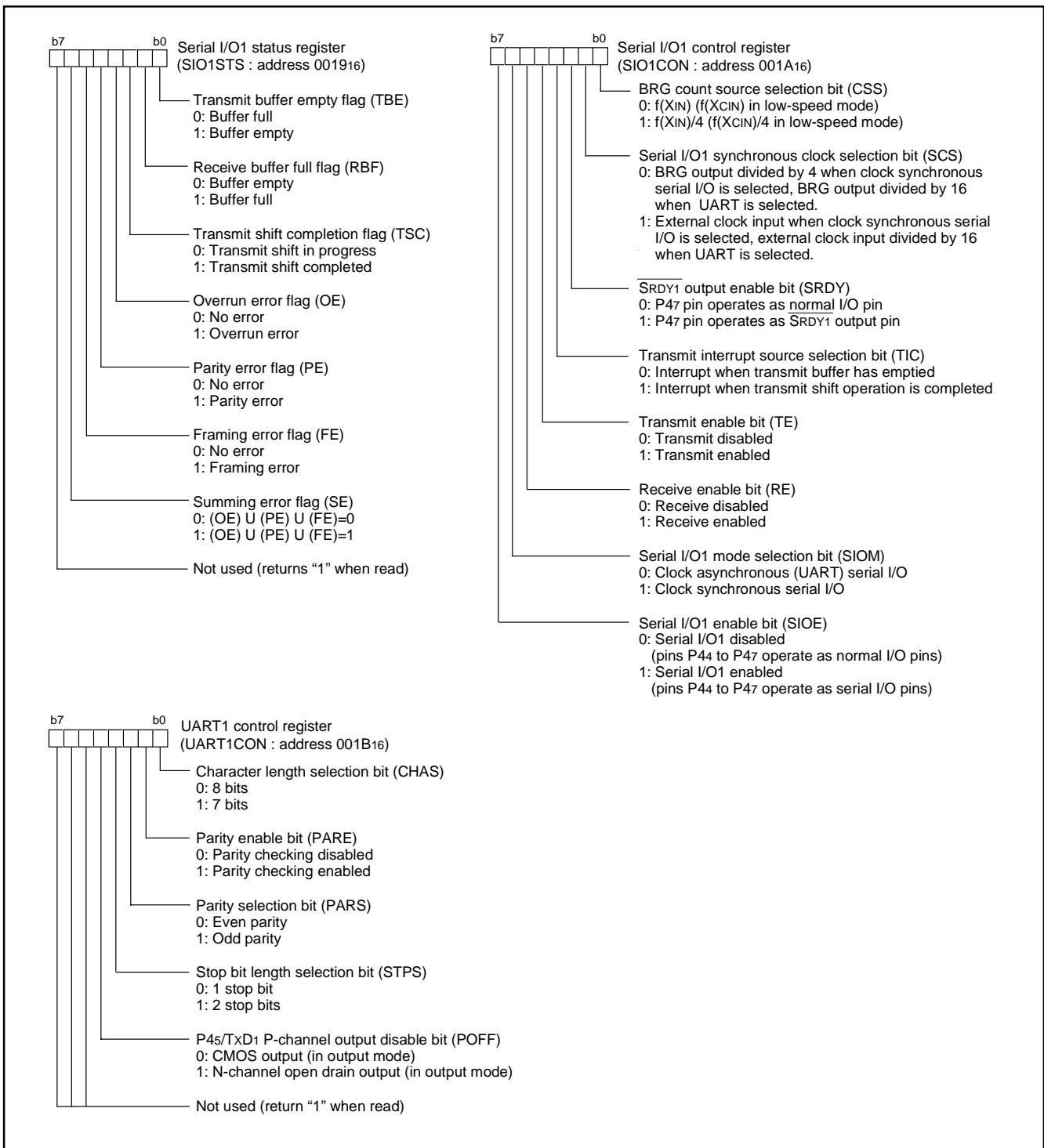

Fig. 37 Structure of serial I/O1 control registers

**■ Notes concerning serial I/O1****1. Notes when selecting clock synchronous serial I/O****1.1 Stop of transmission operation****● Note**

Clear the serial I/O1 enable bit and the transmit enable bit to "0" (serial I/O and transmit disabled).

**● Reason**

Since transmission is not stopped and the transmission circuit is not initialized even if only the serial I/O1 enable bit is cleared to "0" (serial I/O disabled), the internal transmission is running (in this case, since pins TxD1, RxD1, SCLK1, and  $\overline{\text{SRDY1}}$  function as I/O ports, the transmission data is not output). When data is written to the transmit buffer register in this state, data starts to be shifted to the transmit shift register. When the serial I/O1 enable bit is set to "1" at this time, the data during internally shifting is output to the TxD1 pin and an operation failure occurs.

**1.2 Stop of receive operation****● Note**

Clear the receive enable bit to "0" (receive disabled), or clear the serial I/O1 enable bit to "0" (serial I/O disabled).

**1.3 Stop of transmit/receive operation****● Note**

Clear both the transmit enable bit and receive enable bit to "0" (transmit and receive disabled).

(when data is transmitted and received in the clock synchronous serial I/O mode, any one of data transmission and reception cannot be stopped.)

**● Reason**

In the clock synchronous serial I/O mode, the same clock is used for transmission and reception. If any one of transmission and reception is disabled, a bit error occurs because transmission and reception cannot be synchronized.

In this mode, the clock circuit of the transmission circuit also operates for data reception. Accordingly, the transmission circuit does not stop by clearing only the transmit enable bit to "0" (transmit disabled). Also, the transmission circuit is not initialized by clearing the serial I/O1 enable bit to "0" (serial I/O disabled) (refer to 1.1).

**2. Notes when selecting clock asynchronous serial I/O****2.1 Stop of transmission operation****● Note**

Clear the transmit enable bit to "0" (transmit disabled). The transmission operation does not stop by clearing the serial I/O1 enable bit to "0".

**● Reason**

Since transmission is not stopped and the transmission circuit is not initialized even if only the serial I/O1 enable bit is cleared to "0" (serial I/O disabled), the internal transmission is running (in this case, since pins TxD1, RxD1, SCLK1, and  $\overline{\text{SRDY1}}$  function as I/O ports, the transmission data is not output). When data is written to the transmit buffer register in this state, data starts to be shifted to the transmit shift register. When the serial I/O1 enable bit is set to "1" at this time, the data during internally shifting is output to the TxD1 pin and an operation failure occurs.

**2.2 Stop of receive operation****● Note**

Clear the receive enable bit to "0" (receive disabled).

**2.3 Stop of transmit/receive operation****● Note 1 (only transmission operation is stopped)**

Clear the transmit enable bit to "0" (transmit disabled). The transmission operation does not stop by clearing the serial I/O1 enable bit to "0".

**● Reason**

Since transmission is not stopped and the transmission circuit is not initialized even if only the serial I/O1 enable bit is cleared to "0" (serial I/O disabled), the internal transmission is running (in this case, since pins TxD1, RxD1, SCLK1, and  $\overline{\text{SRDY1}}$  function as I/O ports, the transmission data is not output). When data is written to the transmit buffer register in this state, data starts to be shifted to the transmit shift register. When the serial I/O1 enable bit is set to "1" at this time, the data during internally shifting is output to the TxD1 pin and an operation failure occurs.

**● Note 2 (only receive operation is stopped)**

Clear the receive enable bit to "0" (receive disabled).

**3.  $\overline{\text{SRDY1}}$  output of reception side****● Note**

When signals are output from the  $\overline{\text{SRDY1}}$  pin on the reception side by using an external clock in the clock synchronous serial I/O mode, set all of the receive enable bit, the  $\overline{\text{SRDY1}}$  output enable bit, and the transmit enable bit to "1" (transmit enabled).

**4. Setting serial I/O1 control register again****● Note**

Set the serial I/O1 control register again after the transmission and the reception circuits are reset by clearing both the transmit enable bit and the receive enable bit to "0."

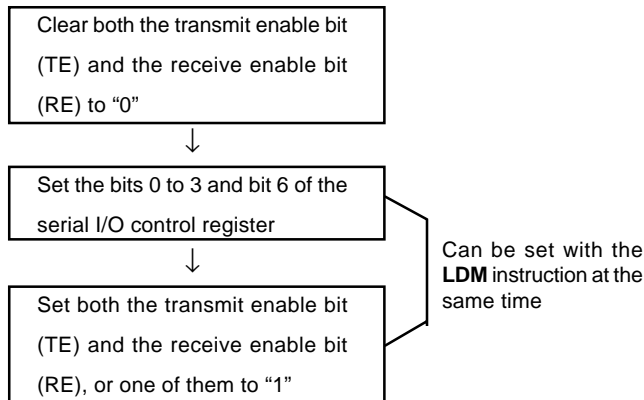
**5. Data transmission control with referring to transmit shift register completion flag****● Note**

After the transmit data is written to the transmit buffer register, the transmit shift register completion flag changes from "1" to "0" with a delay of 0.5 to 1.5 shift clocks. When data transmission is controlled with referring to the flag after writing the data to the transmit buffer register, note the delay.

**6. Transmission control when external clock is selected****● Note**

When an external clock is used as the synchronous clock for data transmission, set the transmit enable bit to "1" at "H" of the SCLK1 input level. Also, write data to the transmit buffer register at "H" of the SCLK1 input level.

**7. Transmit interrupt request when transmit enable bit is set****● Note**

When using the transmit interrupt, take the following sequence.

- ① Set the serial I/O1 transmit interrupt enable bit to "0" (disabled).
- ② Set the transmit enable bit to "1".
- ③ Set the serial I/O1 transmit interrupt request bit to "0" after 1 or more instruction has executed.
- ④ Set the serial I/O1 transmit interrupt enable bit to "1" (enabled).

**● Reason**

When the transmit enable bit is set to "1", the transmit buffer empty flag and the transmit shift register shift completion flag are also set to "1". Therefore, regardless of selecting which timing for the generating of transmit interrupts, the interrupt request is generated and the transmit interrupt request bit is set at this point.

**Serial I/O2**

The serial I/O2 function can be used only for clock synchronous serial I/O.

For clock synchronous serial I/O2, the transmitter and the receiver must use the same clock. If the internal clock is used, transfer is started by a write signal to the serial I/O2 register.

**[Serial I/O2 Control Register (SIO2CON)] 001D16**

The serial I/O2 control register contains eight bits which control various serial I/O2 functions.

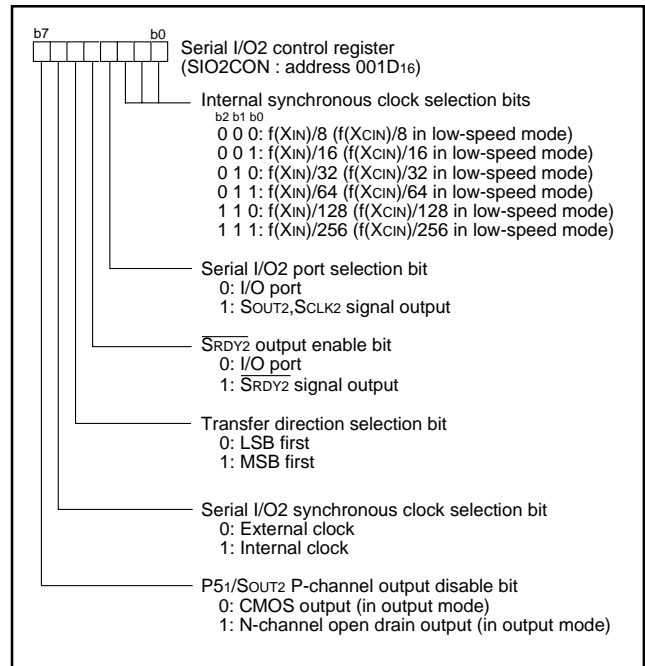

Fig. 38 Structure of serial I/O2 control register

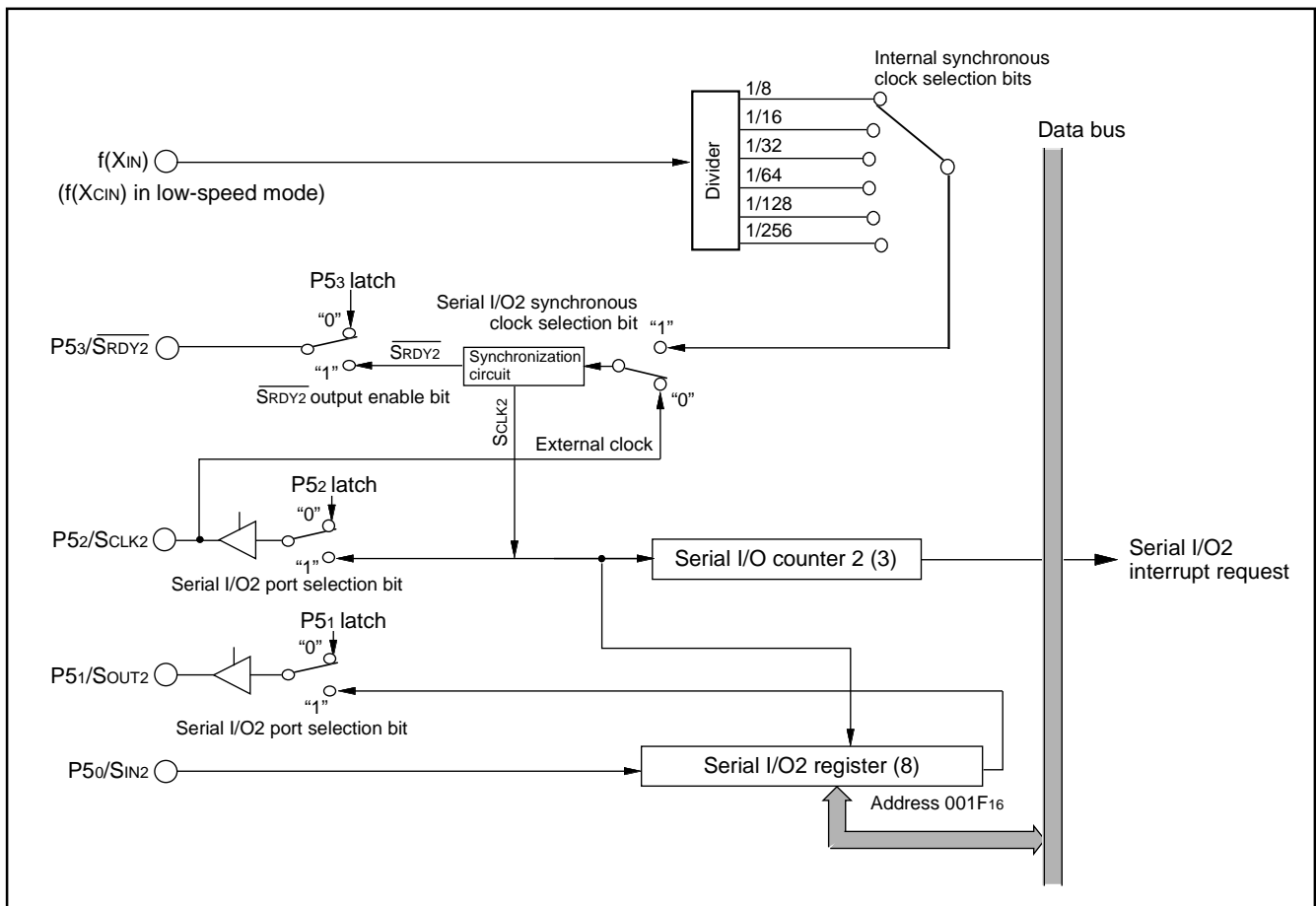

Fig. 39 Block diagram of serial I/O2



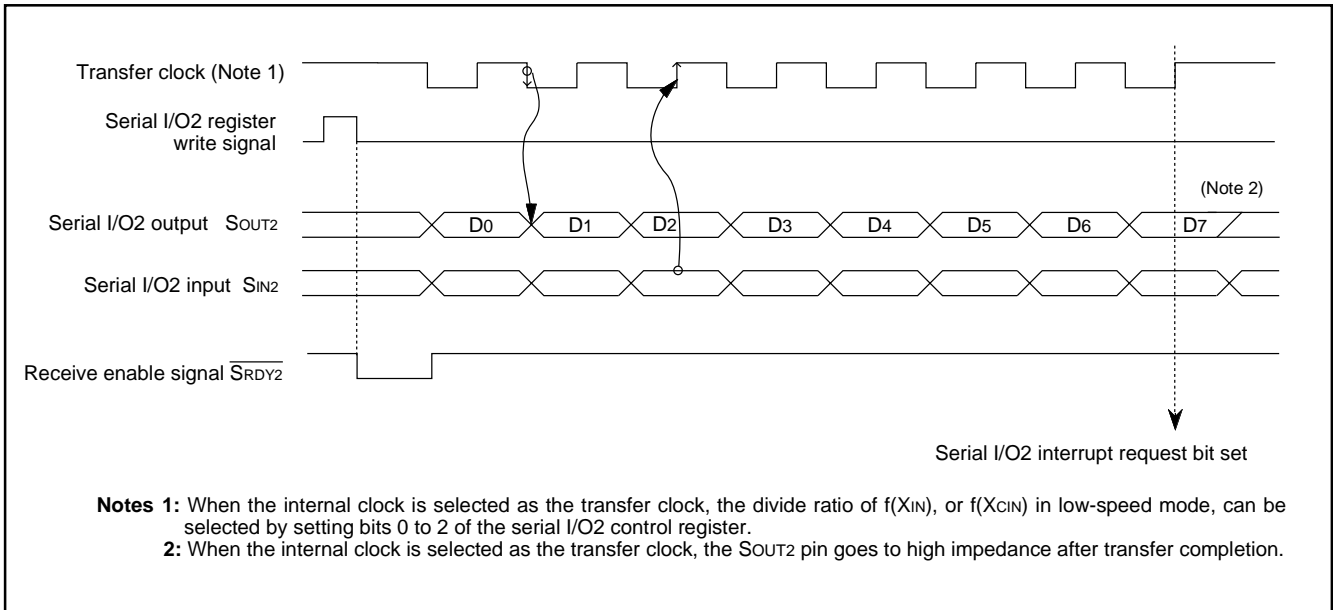

Fig. 40 Timing of serial I/O2

**Serial I/O3**

Serial I/O3 can be used as either clock synchronous or asynchronous (UART) serial I/O. A dedicated timer is also provided for baud rate generation.

**(1) Clock Synchronous Serial I/O Mode**

Clock synchronous serial I/O3 mode can be selected by setting the serial I/O3 mode selection bit of the serial I/O3 control register (bit 6 of address 003216) to "1".

For clock synchronous serial I/O, the transmitter and the receiver must use the same clock. If an internal clock is used, transfer is started by a write signal to the transmit/receive buffer register.

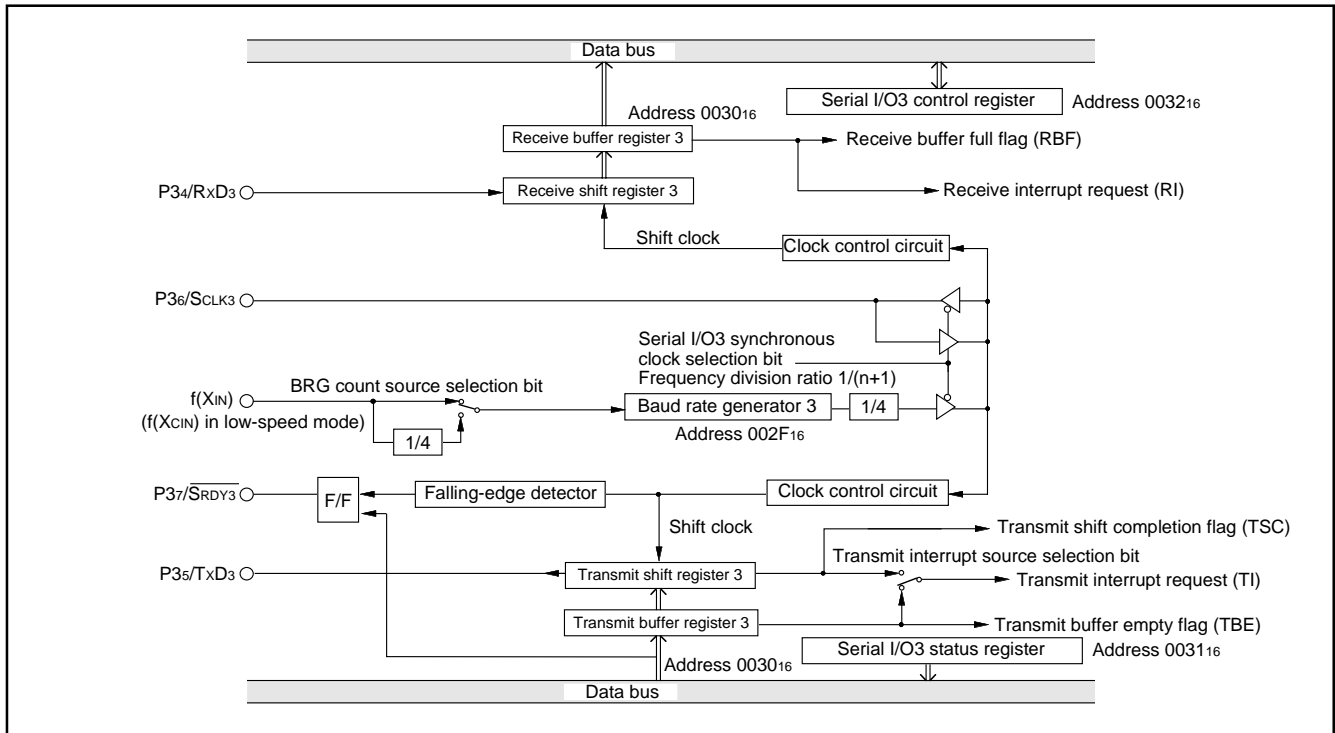

**Fig. 41 Block diagram of clock synchronous serial I/O3**

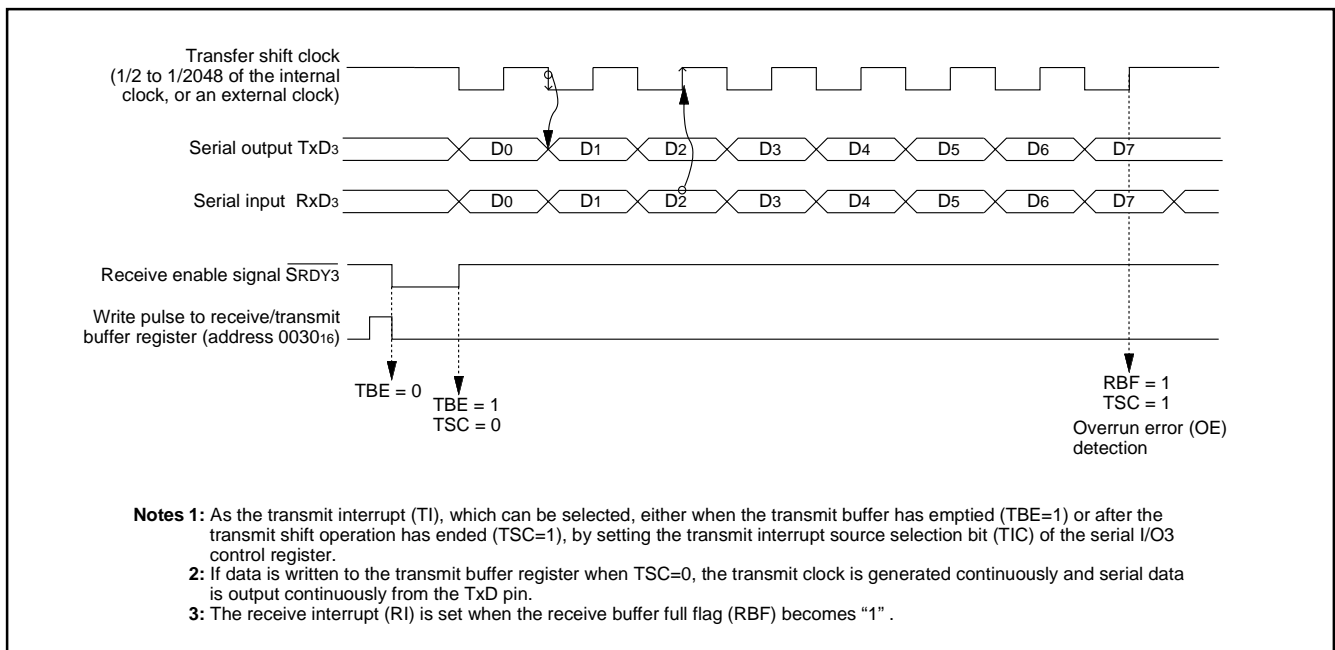

**Fig. 42 Operation of clock synchronous serial I/O3**

## (2) Asynchronous Serial I/O (UART) Mode

Clock asynchronous serial I/O mode (UART) can be selected by clearing the serial I/O3 mode selection bit of the serial I/O3 control register to "0".

Eight serial data transfer formats can be selected, and the transfer formats used by a transmitter and receiver must be identical.

The transmit and receive shift registers each have a buffer, but the

two buffers have the same address in a memory. Since the shift register cannot be written to or read from directly, transmit data is written to the transmit buffer register, and receive data is read from the receive buffer register.

The transmit buffer register can also hold the next data to be transmitted, and the receive buffer register can hold a character while the next character is being received.

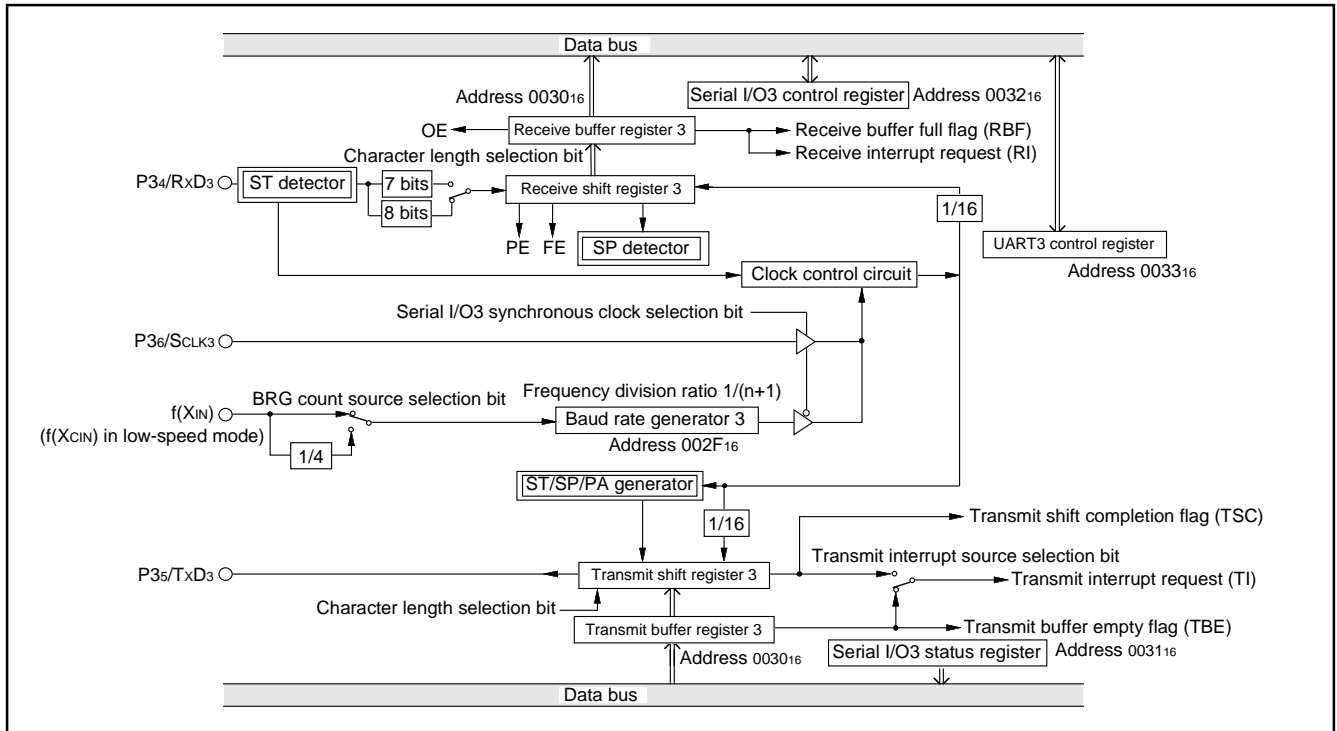

Fig. 43 Block diagram of UART serial I/O3

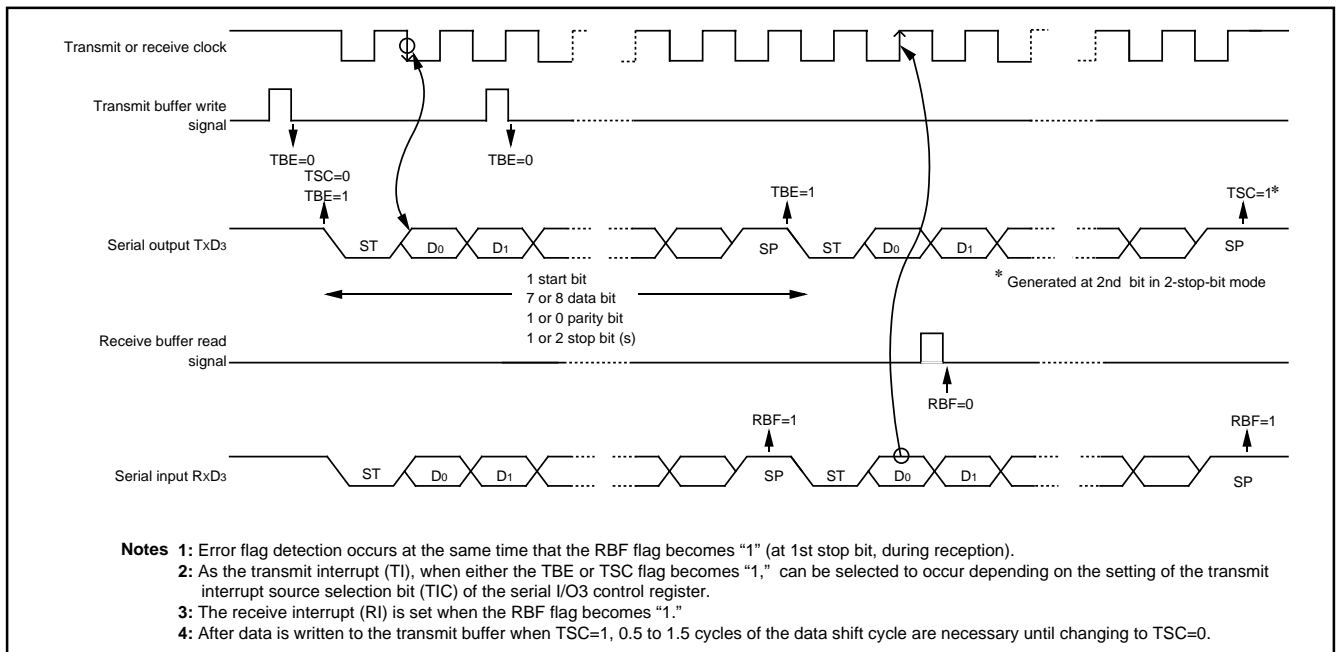

Fig. 44 Operation of UART serial I/O3

**[Serial I/O3 Control Register (SIO3CON)]**  
**003216**

The serial I/O3 control register consists of eight control bits for the serial I/O3 function.

**[UART3 Control Register (UART3CON)]**  
**003316**

The UART control register consists of four control bits (bits 0 to 3) which are valid when asynchronous serial I/O is selected and set the data format of an data transfer, and one bit (bit 4) which is always valid and sets the output structure of the P35/TxD3 pin.

**[Serial I/O3 Status Register (SIO3STS)] 003116**

The read-only serial I/O3 status register consists of seven flags (bits 0 to 6) which indicate the operating status of the serial I/O3 function and various errors.

Three of the flags (bits 4 to 6) are valid only in UART mode.

The receive buffer full flag (bit 1) is cleared to "0" when the receive buffer register is read.

If there is an error, it is detected at the same time that data is transferred from the receive shift register to the receive buffer register, and the receive buffer full flag is set. A write to the serial I/O3 status register clears all the error flags OE, PE, FE, and SE (bit 3 to bit 6, respectively). Writing "0" to the serial I/O3 enable bit SIOE (bit 7 of the serial I/O3 control register) also clears all the status flags, including the error flags.

Bits 0 to 6 of the serial I/O3 status register are initialized to "0" at reset, but if the transmit enable bit (bit 4) of the serial I/O3 control register has been set to "1", the transmit shift completion flag (bit 2) and the transmit buffer empty flag (bit 0) become "1".

**[Transmit Buffer Register 3/Receive Buffer Register 3 (TB3/RB3)] 003016**

The transmit buffer register 3 and the receive buffer register 3 are located at the same address. The transmit buffer is write-only and the receive buffer is read-only. If a character bit length is 7 bits, the MSB of data stored in the receive buffer is "0".

**[Baud Rate Generator 3 (BRG3)] 002F16**

The baud rate generator determines the baud rate for serial transfer.

The baud rate generator divides the frequency of the count source by  $1/(n + 1)$ , where n is the value written to the baud rate generator.

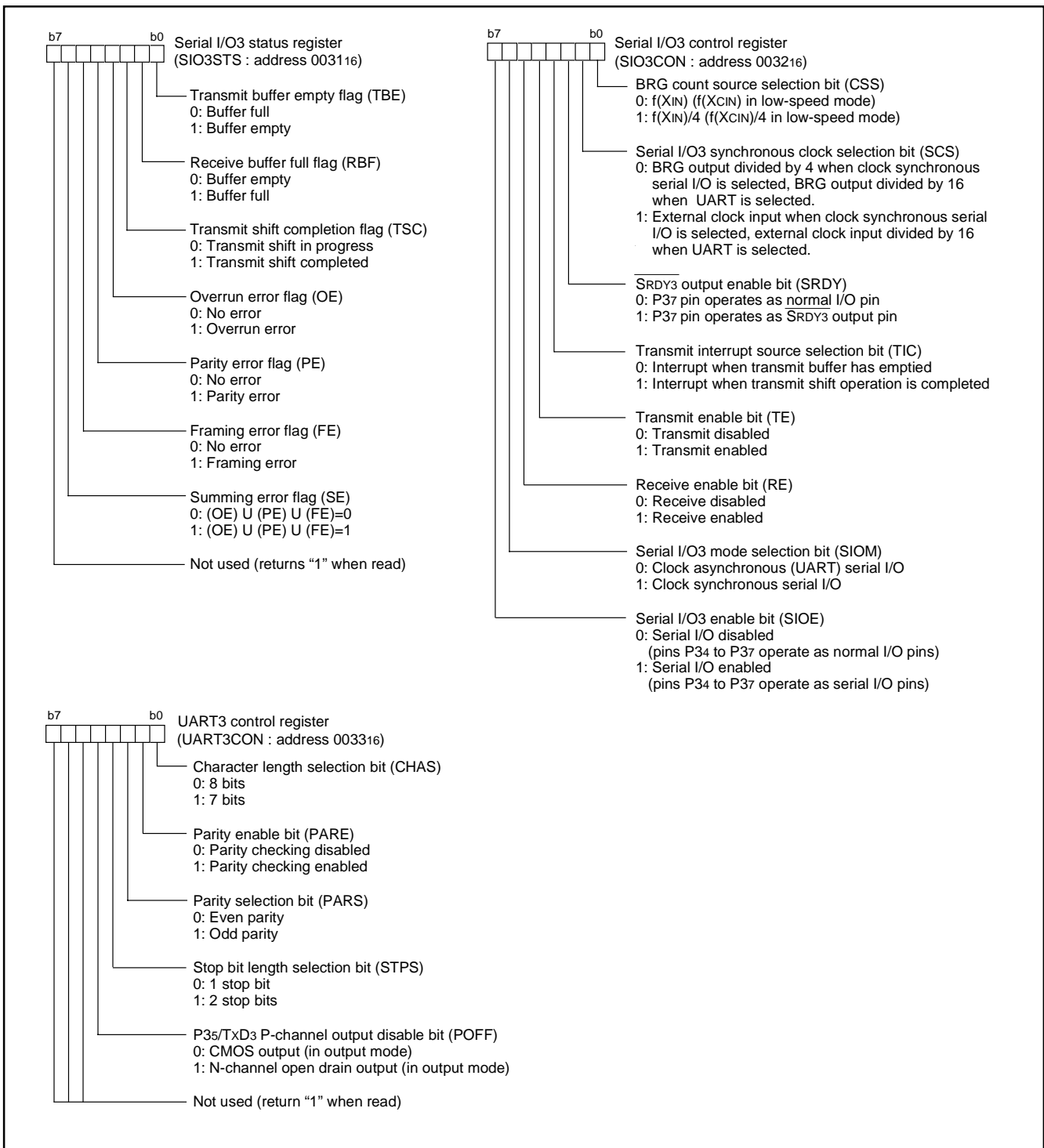

Fig. 45 Structure of serial I/O3 control registers

**■ Notes concerning serial I/O3****1. Notes when selecting clock synchronous serial I/O****1.1 Stop of transmission operation****● Note**

Clear the serial I/O3 enable bit and the transmit enable bit to "0" (serial I/O and transmit disabled).

**● Reason**

Since transmission is not stopped and the transmission circuit is not initialized even if only the serial I/O3 enable bit is cleared to "0" (serial I/O disabled), the internal transmission is running (in this case, since pins TxD3, RxD3, SCLK3, and  $\overline{\text{SRDY3}}$  function as I/O ports, the transmission data is not output). When data is written to the transmit buffer register in this state, data starts to be shifted to the transmit shift register. When the serial I/O enable bit is set to "1" at this time, the data during internally shifting is output to the TxD3 pin and an operation failure occurs.

**1.2 Stop of receive operation****● Note**

Clear the receive enable bit to "0" (receive disabled), or clear the serial I/O3 enable bit to "0" (serial I/O disabled).

**1.3 Stop of transmit/receive operation****● Note**

Clear both the transmit enable bit and receive enable bit to "0" (transmit and receive disabled).

(when data is transmitted and received in the clock synchronous serial I/O mode, any one of data transmission and reception cannot be stopped.)

**● Reason**

In the clock synchronous serial I/O mode, the same clock is used for transmission and reception. If any one of transmission and reception is disabled, a bit error occurs because transmission and reception cannot be synchronized.

In this mode, the clock circuit of the transmission circuit also operates for data reception. Accordingly, the transmission circuit does not stop by clearing only the transmit enable bit to "0" (transmit disabled). Also, the transmission circuit is not initialized by clearing the serial I/O3 enable bit to "0" (serial I/O disabled) (refer to 1.1).

**2. Notes when selecting clock asynchronous serial I/O****2.1 Stop of transmission operation****● Note**

Clear the transmit enable bit to "0" (transmit disabled). The transmission operation does not stop by clearing the serial I/O3 enable bit to "0".

**● Reason**

Since transmission is not stopped and the transmission circuit is not initialized even if only the serial I/O3 enable bit is cleared to "0" (serial I/O disabled), the internal transmission is running (in this case, since pins TxD3, RxD3, SCLK3, and  $\overline{\text{SRDY3}}$  function as I/O ports, the transmission data is not output). When data is written to the transmit buffer register in this state, data starts to be shifted to the transmit shift register. When the serial I/O3 enable bit is set to "1" at this time, the data during internally shifting is output to the TxD3 pin and an operation failure occurs.

**2.2 Stop of receive operation****● Note**

Clear the receive enable bit to "0" (receive disabled).

**2.3 Stop of transmit/receive operation****● Note 1 (only transmission operation is stopped)**

Clear the transmit enable bit to "0" (transmit disabled). The transmission operation does not stop by clearing the serial I/O3 enable bit to "0".

**● Reason**

Since transmission is not stopped and the transmission circuit is not initialized even if only the serial I/O3 enable bit is cleared to "0" (serial I/O disabled), the internal transmission is running (in this case, since pins TxD3, RxD3, SCLK3, and  $\overline{\text{SRDY3}}$  function as I/O ports, the transmission data is not output). When data is written to the transmit buffer register in this state, data starts to be shifted to the transmit shift register. When the serial I/O3 enable bit is set to "1" at this time, the data during internally shifting is output to the TxD3 pin and an operation failure occurs.

**● Note 2 (only receive operation is stopped)**

Clear the receive enable bit to "0" (receive disabled).

**3.  $\overline{\text{SRDY3}}$  output of reception side****● Note**

When signals are output from the  $\overline{\text{SRDY3}}$  pin on the reception side by using an external clock in the clock synchronous serial I/O mode, set all of the receive enable bit, the  $\overline{\text{SRDY3}}$  output enable bit, and the transmit enable bit to "1" (transmit enabled).

**4. Setting serial I/O3 control register again****● Note**

Set the serial I/O3 control register again after the transmission and the reception circuits are reset by clearing both the transmit enable bit and the receive enable bit to "0."

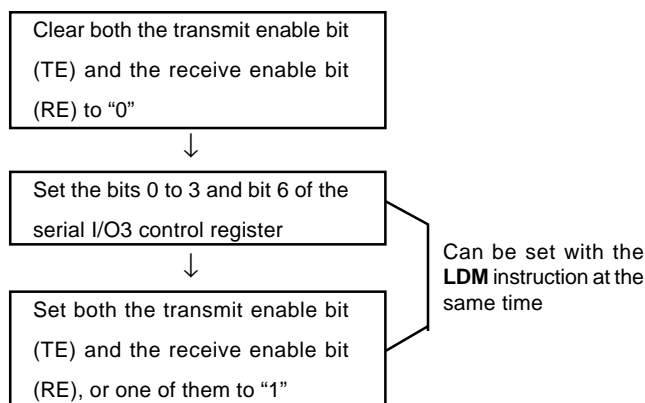
**5. Data transmission control with referring to transmit shift register completion flag****● Note**

After the transmit data is written to the transmit buffer register, the transmit shift register completion flag changes from "1" to "0" with a delay of 0.5 to 1.5 shift clocks. When data transmission is controlled with referring to the flag after writing the data to the transmit buffer register, note the delay.

**6. Transmission control when external clock is selected****● Note**

When an external clock is used as the synchronous clock for data transmission, set the transmit enable bit to "1" at "H" of the SCLK3 input level. Also, write data to the transmit buffer register at "H" of the SCLK input level.

**7. Transmit interrupt request when transmit enable bit is set****● Note**

When using the transmit interrupt, take the following sequence.

- ① Set the serial I/O3 transmit interrupt enable bit to "0" (disabled).
- ② Set the transmit enable bit to "1".
- ③ Set the serial I/O3 transmit interrupt request bit to "0" after 1 or more instruction has executed.
- ④ Set the serial I/O3 transmit interrupt enable bit to "1" (enabled).

**● Reason**

When the transmit enable bit is set to "1", the transmit buffer empty flag and the transmit shift register shift completion flag are also set to "1". Therefore, regardless of selecting which timing for the generating of transmit interrupts, the interrupt request is generated and the transmit interrupt request bit is set at this point.

### PULSE WIDTH MODULATION (PWM)

The 3803 group (Spec. H) has PWM functions with an 8-bit resolution, based on a signal that is the clock input X<sub>IN</sub> or that clock input divided by 2 or the clock input X<sub>CIN</sub> or that clock input divided by 2 in low-speed mode.

#### Data Setting

The PWM output pin also functions as port P5<sub>6</sub>. Set the PWM period by the PWM prescaler, and set the "H" term of output pulse by the PWM register.

If the value in the PWM prescaler is n and the value in the PWM register is m (where n = 0 to 255 and m = 0 to 255) :

$$\begin{aligned} \text{PWM period} &= 255 \times (n+1) / f(X_{IN}) \\ &= 31.875 \times (n+1) \mu\text{s} \quad (\text{when } f(X_{IN}) = 8 \text{ MHz}) \end{aligned}$$

$$\begin{aligned} \text{Output pulse "H" term} &= \text{PWM period} \times m / 255 \\ &= 0.125 \times (n+1) \times m \mu\text{s} \\ &\quad (\text{when } f(X_{IN}) = 8 \text{ MHz}) \end{aligned}$$

### PWM Operation

When bit 0 (PWM enable bit) of the PWM control register is set to "1", operation starts by initializing the PWM output circuit, and pulses are output starting at an "H".

If the PWM register or PWM prescaler is updated during PWM output, the pulses will change in the cycle after the one in which the change was made.

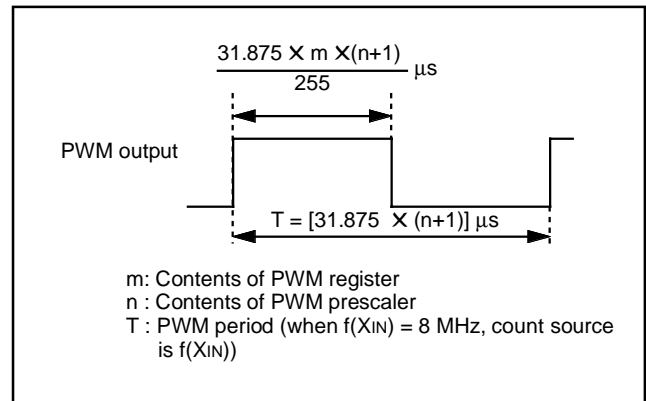

Fig. 46 Timing of PWM period

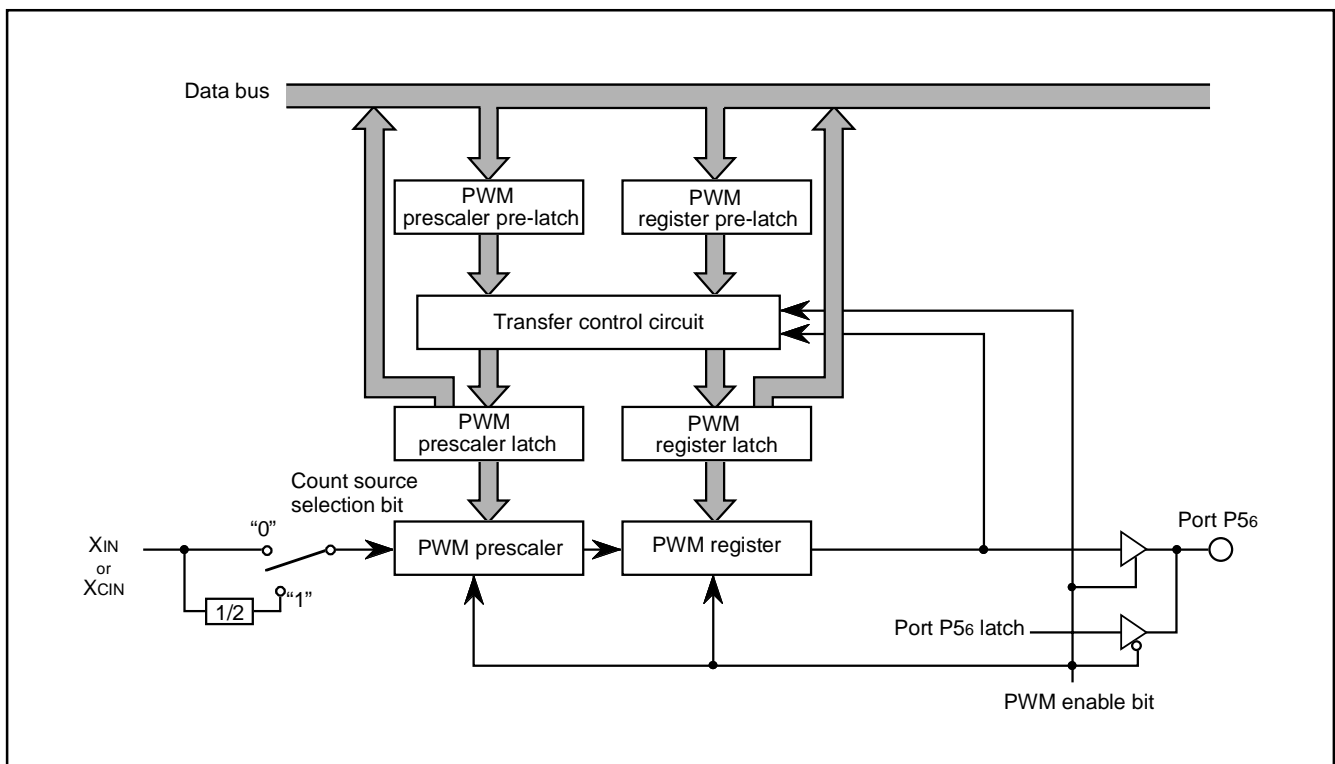

Fig. 47 Block diagram of PWM function



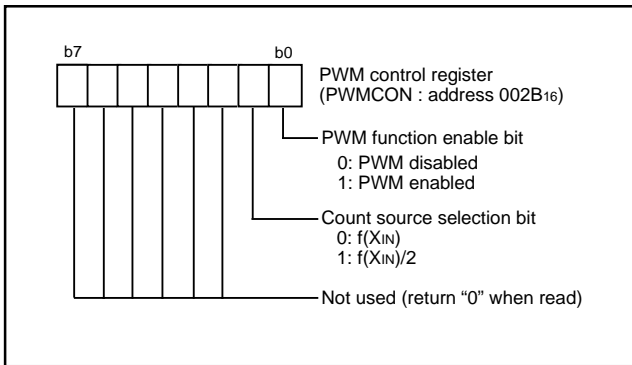

Fig. 48 Structure of PWM control register

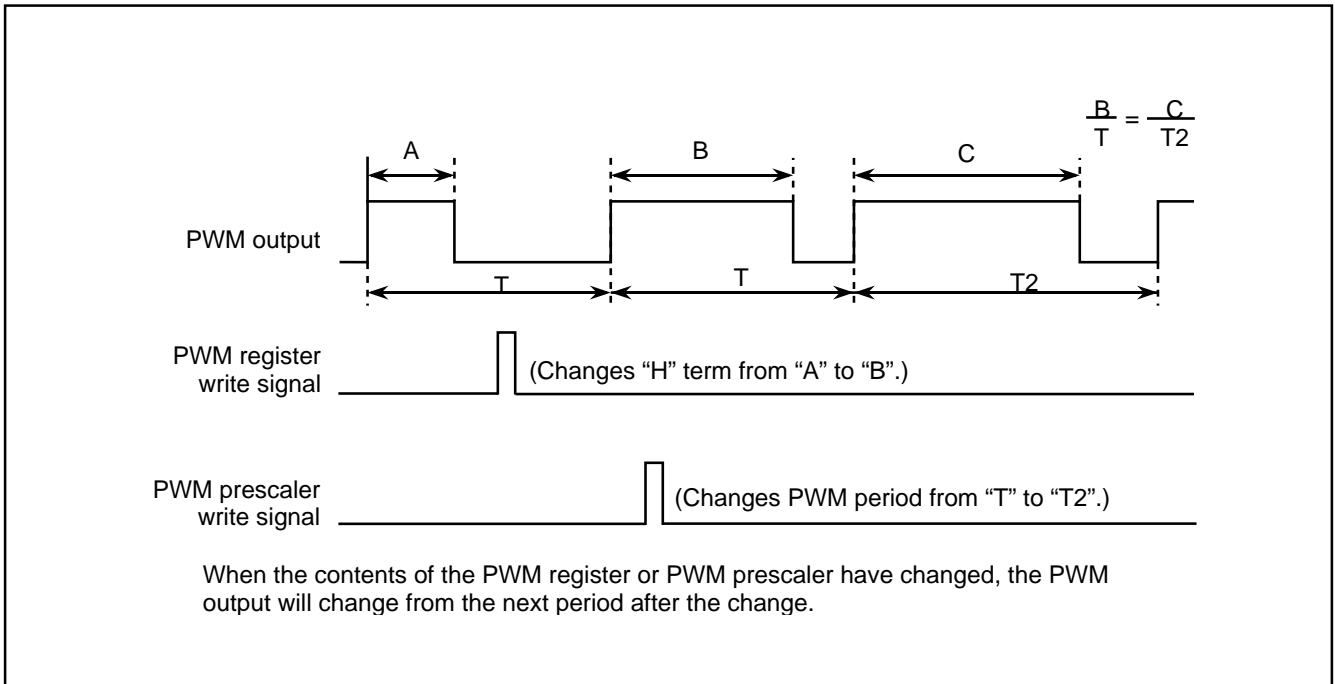

Fig. 49 PWM output timing when PWM register or PWM prescaler is changed

**A-D CONVERTER**

**[A-D Conversion Register 1, 2 (AD1, AD2)]  
003516, 003816**

The A-D conversion register is a read-only register that stores the result of an A-D conversion. When reading this register during an A-D conversion, the previous conversion result is read.

Bit 7 of the A-D conversion register 2 is the conversion mode selection bit. When this bit is set to "0," the A-D converter becomes the 10-bit A-D mode. When this bit is set to "1," that becomes the 8-bit A-D mode. The conversion result of the 8-bit A-D mode is stored in the A-D conversion register 1. As for 10-bit A-D mode, not only 10-bit reading but also only high-order 8-bit reading of conversion result can be performed by selecting the reading procedure of the A-D conversion registers 1, 2 after A-D conversion is completed (in Figure 51).

As for 10-bit A-D mode, the 8-bit reading inclined to MSB is performed when reading the A-D converter register 1 after A-D conversion is started; and when the A-D converter register 1 is read after reading the A-D converter register 2, the 8-bit reading inclined to LSB is performed.

**[AD/DA Control Register (ADCON)] 003416**

The AD/DA control register controls the A-D conversion process. Bits 0 to 2 and bit 4 select a specific analog input pin. Bit 3 signals the completion of an A-D conversion. The value of this bit remains at "0" during an A-D conversion, and changes to "1" when an A-D conversion ends. Writing "0" to this bit starts the A-D conversion.

**Comparison Voltage Generator**

The comparison voltage generator divides the voltage between VREF and AVSS into 1024, and that outputs the comparison voltage in the 10-bit A-D mode (256 division in 8-bit A-D mode).

The A-D converter successively compares the comparison voltage Vref in each mode, dividing the VREF voltage (see below), with the input voltage.

- 10-bit A-D mode (10-bit reading)

$$V_{ref} = \frac{V_{REF}}{1024} \times n \quad (n = 0-1023)$$

- 10-bit A-D mode (8-bit reading)

$$V_{ref} = \frac{V_{REF}}{256} \times n \quad (n = 0-255)$$

- 8-bit A-D mode

$$V_{ref} = \frac{V_{REF}}{256} \times (n-0.5) \quad (n = 1-255)$$

$$= 0 \quad (n = 0)$$

**Channel Selector**

The channel selector selects one of ports P67/AN7 to P60/AN0 or P07/AN15 to P00/AN8, and inputs the voltage to the comparator.

**Comparator and Control Circuit**

The comparator and control circuit compares an analog input voltage with the comparison voltage, and then stores the result in the A-D conversion registers 1, 2. When an A-D conversion is completed, the control circuit sets the AD conversion completion bit and the AD interrupt request bit to "1".

Note that because the comparator consists of a capacitor coupling, set f(XIN) to 500 kHz or more during an A-D conversion.

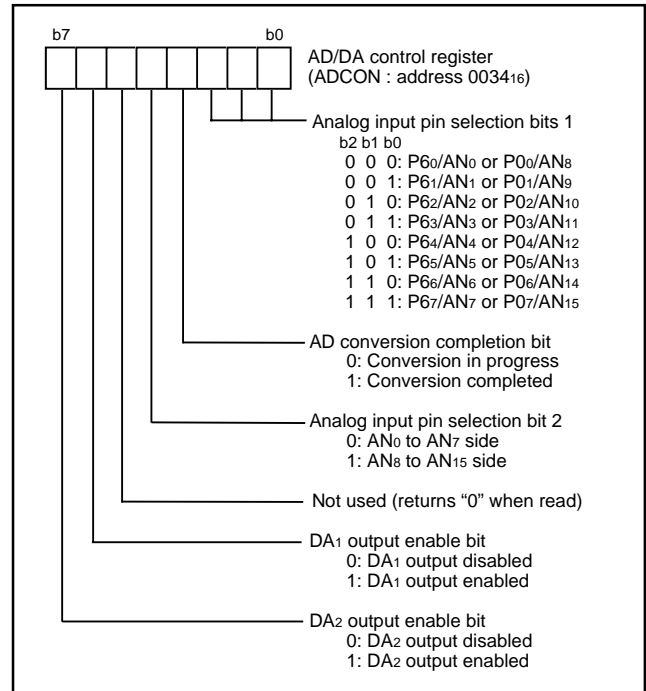

Fig. 50 Structure of AD/DA control register

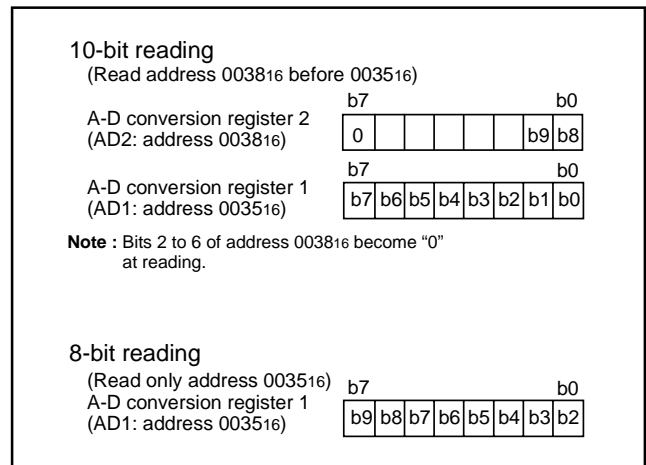

Fig. 51 Structure of 10-bit A-D mode reading

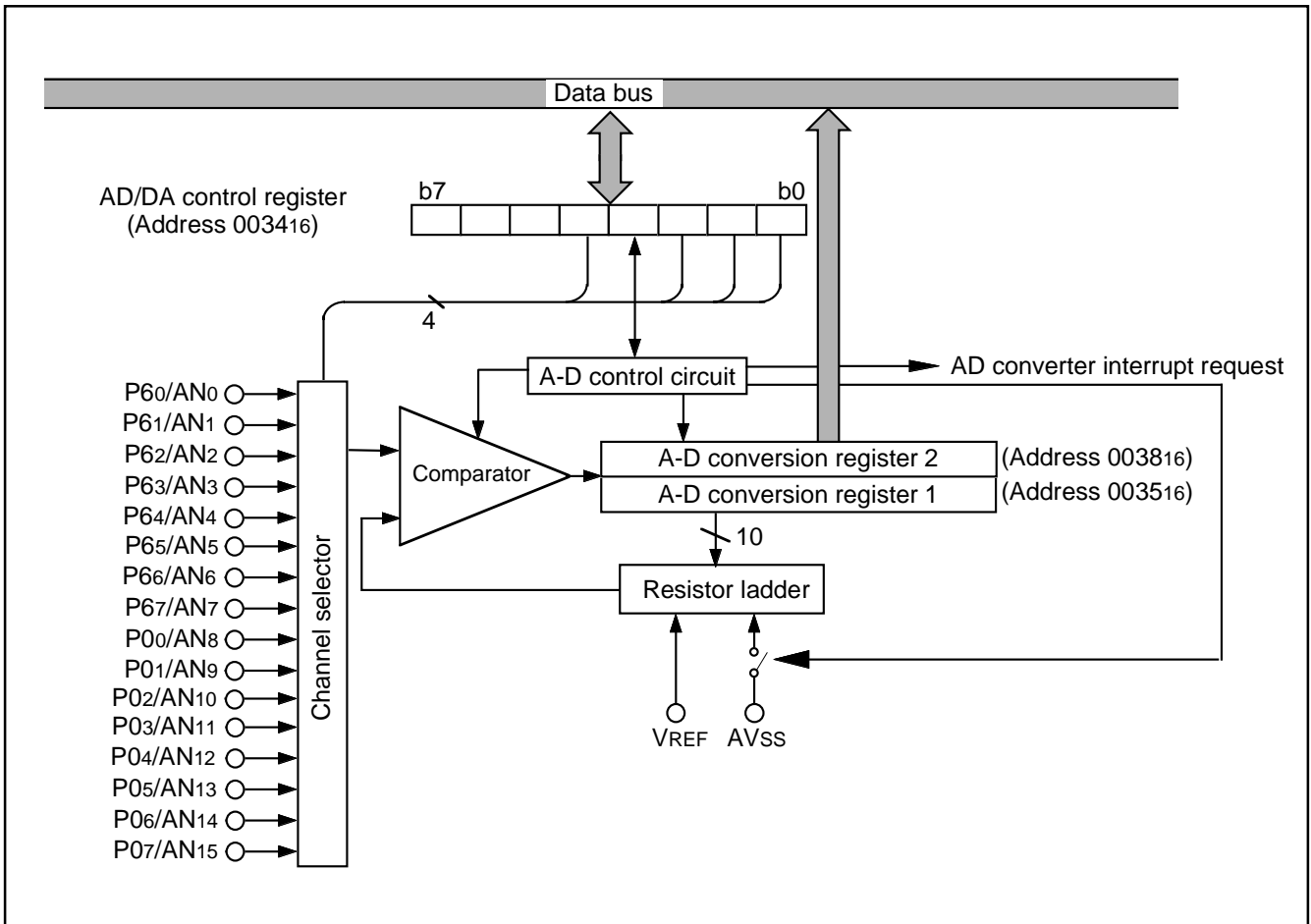

Fig. 52 Block diagram of A-D converter

### D-A CONVERTER

The 3803 group (Spec. H) has two internal D-A converters (DA1 and DA2) with 8-bit resolution.

The D-A conversion is performed by setting the value in each D-A conversion register. The result of D-A conversion is output from the DA1 or DA2 pin by setting the DA output enable bit to "1".

When using the D-A converter, the corresponding port direction register bit (P30/DA1 or P31/DA2) must be set to "0" (input status). The output analog voltage  $V$  is determined by the value  $n$  (decimal notation) in the D-A conversion register as follows:

$$V = V_{REF} \times n / 256 \quad (n = 0 \text{ to } 255)$$

Where  $V_{REF}$  is the reference voltage.

At reset, the D-A conversion registers are cleared to "0016", and the DA output enable bits are cleared to "0", and the P30/DA1 and P31/DA2 pins become high impedance.

The DA output does not have buffers. Accordingly, connect an external buffer when driving a low-impedance load.

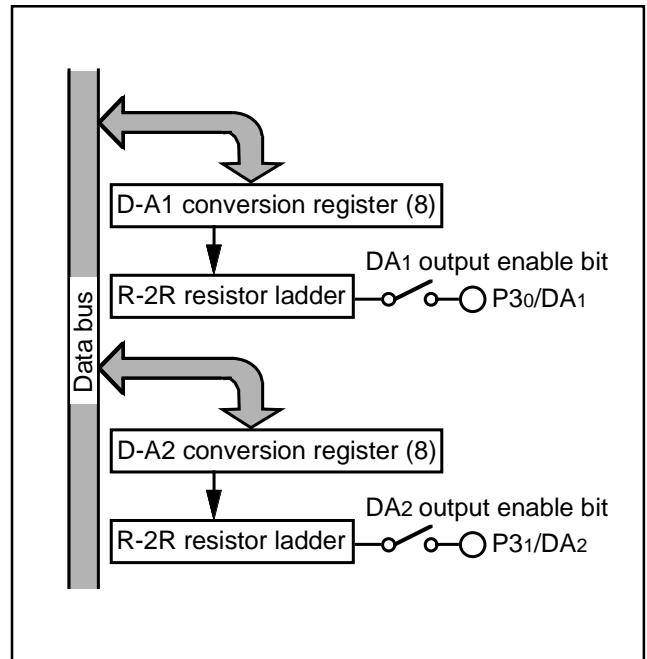

Fig. 53 Block diagram of D-A converter

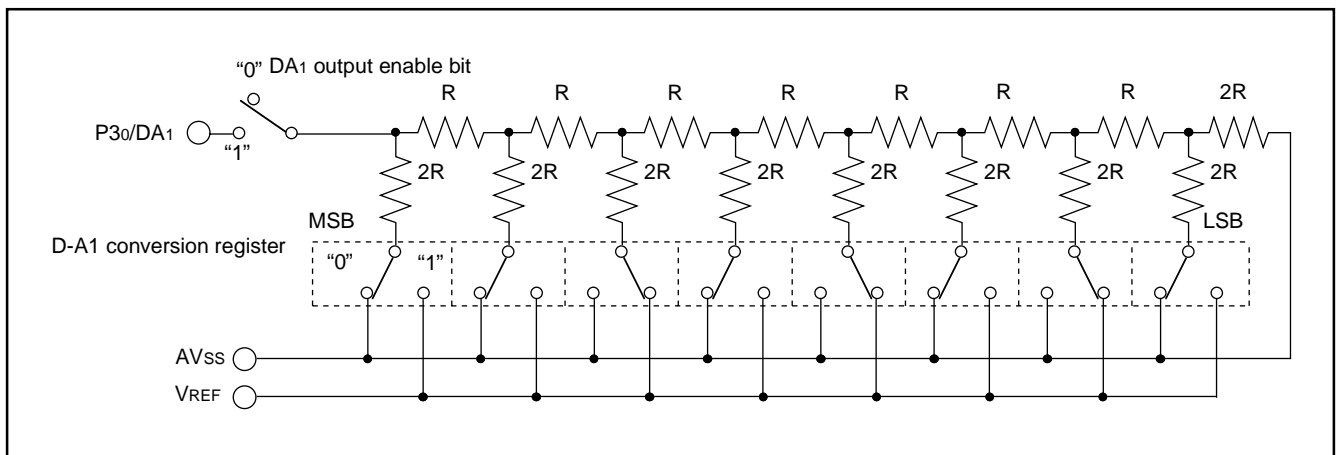

Fig. 54 Equivalent connection circuit of D-A converter (DA1)

### WATCHDOG TIMER

The watchdog timer gives a mean of returning to the reset status when a program cannot run on a normal loop (for example, because of a software run-away). The watchdog timer consists of an 8-bit watchdog timer L and an 8-bit watchdog timer H.

#### Watchdog Timer Initial Value

Watchdog timer L is set to "FF16" and watchdog timer H is set to "FF16" by writing to the watchdog timer control register (address 001E16) or at a reset. Any write instruction that causes a write signal can be used, such as the STA, LDM, CLB, etc. Data can only be written to bits 6 and 7 of the watchdog timer control register. Regardless of the value written to bits 0 to 5, the above-mentioned value will be set to each timer.

#### Watchdog Timer Operations

The watchdog timer stops at reset and a countdown is started by the writing to the watchdog timer control register. An internal reset occurs when watchdog timer H underflows. The reset is released after its release time. After the release, the program is restarted from the reset vector address. Usually, write to the watchdog timer control register by software before an underflow of the watchdog timer H. The watchdog timer does not function if the watchdog timer control register is not written to at least once.

When bit 6 of the watchdog timer control register is kept at "0", the STP instruction is enabled. When that is executed, both the clock and the watchdog timer stop. Count re-starts at the same time as the release of stop mode (**Note**). The watchdog timer does not stop while a WIT instruction is executed. In addition, the STP instruction is disabled by writing "1" to this bit again. When the STP instruction is executed at this time, it is processed as an undefined instruction, and an internal reset occurs. Once a "1" is written to this bit, it cannot be programmed to "0" again.

The following shows the period between the write execution to the watchdog timer control register and the underflow of watchdog timer H.

Bit 7 of the watchdog timer control register is "0":

- when XCIN = 32.768 kHz; 32 s
- when XIN = 16 MHz; 65.536 ms

Bit 7 of the watchdog timer control register is "1":

- when XCIN = 32.768 kHz; 125 ms
- when XIN = 16 MHz; 256 μs

**Note:** The watchdog timer continues to count even while waiting for a stop release. Therefore, make sure that watchdog timer H does not underflow during this period.

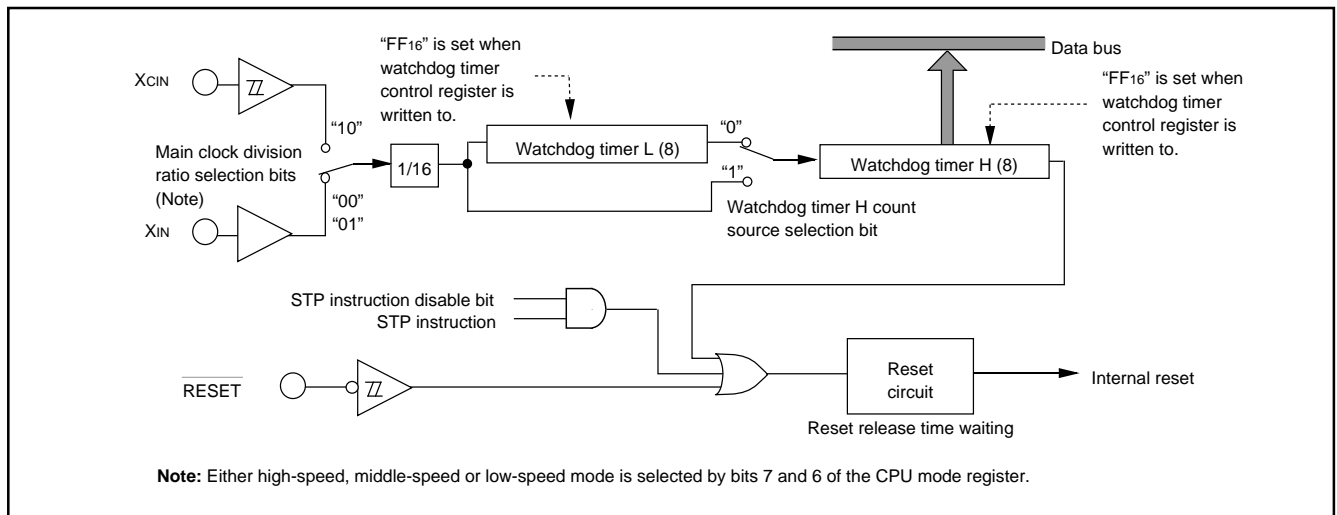

Fig. 55 Block diagram of Watchdog timer

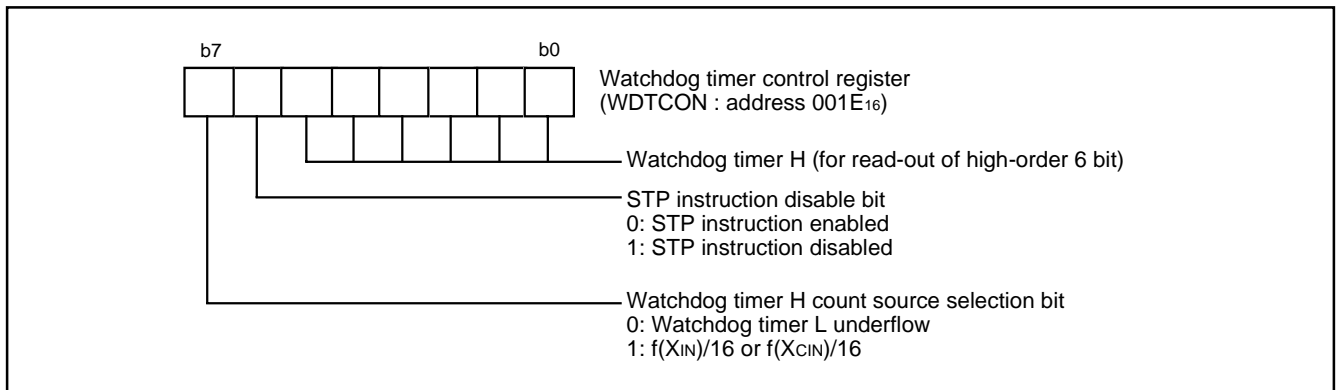

Fig. 56 Structure of Watchdog timer control register

### RESET CIRCUIT

To reset the microcomputer,  $\overline{\text{RESET}}$  pin should be held at an "L" level for 16 cycles or more of  $X_{IN}$ . Then the  $\overline{\text{RESET}}$  pin is returned to an "H" level (the power source voltage should be between 1.8 V and 5.5 V (between 2.7 V to 5.5 V for flash memory version), and the oscillation should be stable), reset is released. After the reset is completed, the program starts from the address contained in address  $\text{FFFD}_{16}$  (high-order byte) and address  $\text{FFFC}_{16}$  (low-order byte). Make sure that the reset input voltage for the mask ROM version is less than 0.29 V for  $V_{CC}$  of 1.8 V.

In the flash memory version, input to the  $\overline{\text{RESET}}$  pin in the following procedure.

- When power source is stabilized
  - (1) Input "L" level to  $\overline{\text{RESET}}$  pin.
  - (2) Input "L" level for 16 cycles or more to  $X_{IN}$  pin.
  - (3) Input "H" level to  $\overline{\text{RESET}}$  pin.
- At power-on
  - (1) Input "L" level to  $\overline{\text{RESET}}$  pin.
  - (2) Increase the power source voltage to 2.7 V.
  - (3) Wait for  $t_d(P-R)$  until internal power source has stabilized.
  - (4) Input "L" level for 16 cycles or more to  $X_{IN}$  pin.
  - (5) Input "H" level to  $\overline{\text{RESET}}$  pin.

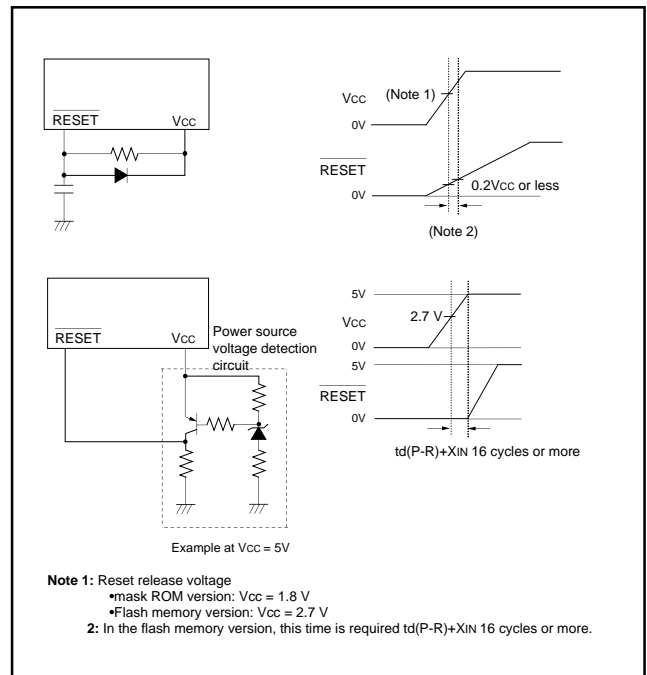

Fig. 57 Reset circuit example

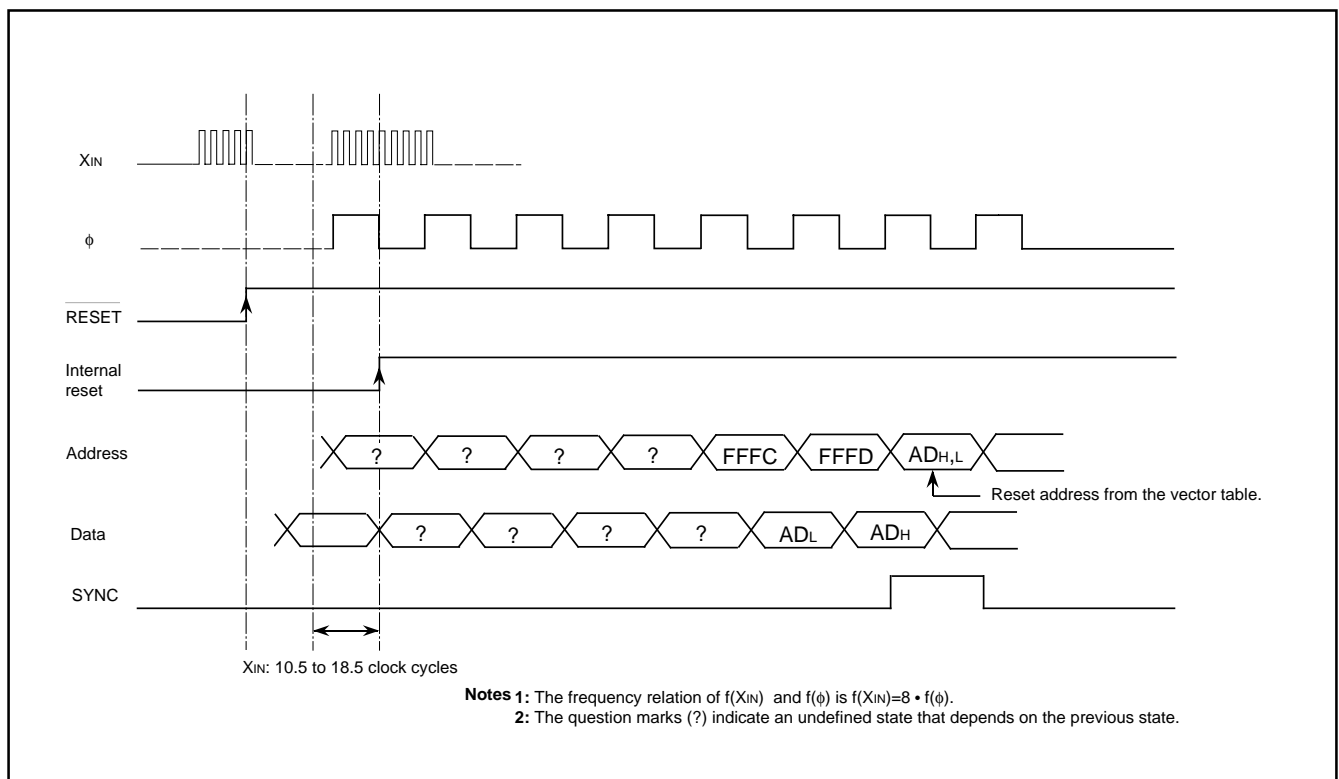

Fig. 58 Reset sequence

	Address	Register contents		Address	Register contents
(1) Port P0 (P0)	0000 <sub>16</sub>	00 <sub>16</sub>	(34) Timer Z (low-order) (TZL)	0028 <sub>16</sub>	FF <sub>16</sub>
(2) Port P0 direction register (P0D)	0001 <sub>16</sub>	00 <sub>16</sub>	(35) Timer Z (high-order) (TZH)	0029 <sub>16</sub>	FF <sub>16</sub>
(3) Port P1 (P1)	0002 <sub>16</sub>	00 <sub>16</sub>	(36) Timer Z mode register (TZM)	002A <sub>16</sub>	00 <sub>16</sub>
(4) Port P1 direction register (P1D)	0003 <sub>16</sub>	00 <sub>16</sub>	(37) PWM control register (PWMCN)	002B <sub>16</sub>	00 <sub>16</sub>
(5) Port P2 (P2)	0004 <sub>16</sub>	00 <sub>16</sub>	(38) PWM prescaler (PREPWM)	002C <sub>16</sub>	X X X X X X X X
(6) Port P2 direction register (P2D)	0005 <sub>16</sub>	00 <sub>16</sub>	(39) PWM register (PWM)	002D <sub>16</sub>	X X X X X X X X
(7) Port P3 (P3)	0006 <sub>16</sub>	00 <sub>16</sub>	(40) Baud rate generator 3 (BRG3)	002F <sub>16</sub>	X X X X X X X X
(8) Port P3 direction register (P3D)	0007 <sub>16</sub>	00 <sub>16</sub>	(41) Transmit/Receive buffer register 3 (TB3/RB3)	0030 <sub>16</sub>	X X X X X X X X
(9) Port P4 (P4)	0008 <sub>16</sub>	00 <sub>16</sub>	(42) Serial I/O3 status register (SIO3STS)	0031 <sub>16</sub>	1 0 0 0 0 0 0 0
(10) Port P4 direction register (P4D)	0009 <sub>16</sub>	00 <sub>16</sub>	(43) Serial I/O3 control register (SIO3CN)	0032 <sub>16</sub>	00 <sub>16</sub>
(11) Port P5 (P5)	000A <sub>16</sub>	00 <sub>16</sub>	(44) UART3 control register (UART3CN)	0033 <sub>16</sub>	1 1 1 0 0 0 0 0
(12) Port P5 direction register (P5D)	000B <sub>16</sub>	00 <sub>16</sub>	(45) AD/DA control register (ADCN)	0034 <sub>16</sub>	0 0 0 0 1 0 0 0
(13) Port P6 (P6)	000C <sub>16</sub>	00 <sub>16</sub>	(46) A-D conversion register 1 (AD1)	0035 <sub>16</sub>	X X X X X X X X
(14) Port P6 direction register (P6D)	000D <sub>16</sub>	00 <sub>16</sub>	(47) D-A1 conversion register (DA1)	0036 <sub>16</sub>	00 <sub>16</sub>
(15) Timer 12, X count source selection register (T12XCSS)	000E <sub>16</sub>	0 0 1 1 0 0 1 1	(48) D-A2 conversion register (DA2)	0037 <sub>16</sub>	00 <sub>16</sub>
(16) Timer Y, Z count source selection register (TYZCSS)	000F <sub>16</sub>	0 0 1 1 0 0 1 1	(49) A-D conversion register 2 (AD2)	0038 <sub>16</sub>	0 0 0 0 0 0 X X
(17) MISRG	0010 <sub>16</sub>	00 <sub>16</sub>	(50) Interrupt source selection register (INTSEL)	0039 <sub>16</sub>	00 <sub>16</sub>
(18) Transmit/Receive buffer register 1 (TB1/RB1)	0018 <sub>16</sub>	X X X X X X X X	(51) Interrupt edge selection register (INTEGE)	003A <sub>16</sub>	00 <sub>16</sub>
(19) Serial I/O1 status register (SIO1STS)	0019 <sub>16</sub>	1 0 0 0 0 0 0 0	(52) CPU mode register (CPUM)	003B <sub>16</sub>	0 1 0 0 1 0 0 0
(20) Serial I/O1 control register (SIO1CN)	001A <sub>16</sub>	00 <sub>16</sub>	(53) Interrupt request register 1 (IREQ1)	003C <sub>16</sub>	00 <sub>16</sub>
(21) UART1 control register (UART1CN)	001B <sub>16</sub>	1 1 1 0 0 0 0 0	(54) Interrupt request register 2 (IREQ2)	003D <sub>16</sub>	00 <sub>16</sub>
(22) Baud rate generator 1 (BRG1)	001C <sub>16</sub>	X X X X X X X X	(55) Interrupt control register 1 (ICON1)	003E <sub>16</sub>	00 <sub>16</sub>
(23) Serial I/O2 control register (SIO2CN)	001D <sub>16</sub>	00 <sub>16</sub>	(56) Interrupt control register 2 (ICON2)	003F <sub>16</sub>	00 <sub>16</sub>
(24) Watchdog timer control register (WDTCON)	001E <sub>16</sub>	0 0 1 1 1 1 1 1	(57) Flash memory control register 0 (FMCR0)	0FE0 <sub>16</sub>	0 0 0 0 0 0 0 1
(25) Serial I/O2 register (SIO2)	001F <sub>16</sub>	X X X X X X X X	(58) Flash memory control register 1 (FMCR1)	0FE1 <sub>16</sub>	0 1 0 0 0 0 0 0
(26) Prescaler 12 (PRE12)	0020 <sub>16</sub>	FF <sub>16</sub>	(59) Flash memory control register 2 (FMCR2)	0FE2 <sub>16</sub>	0 1 0 0 0 1 0 1
(27) Timer 1 (T1)	0021 <sub>16</sub>	01 <sub>16</sub>	(60) Port P0 pull-up control register (PULL0)	0FF0 <sub>16</sub>	00 <sub>16</sub>
(28) Timer 2 (T2)	0022 <sub>16</sub>	FF <sub>16</sub>	(61) Port P1 pull-up control register (PULL1)	0FF1 <sub>16</sub>	00 <sub>16</sub>
(29) Timer XY mode register (TM)	0023 <sub>16</sub>	00 <sub>16</sub>	(62) Port P2 pull-up control register (PULL2)	0FF2 <sub>16</sub>	00 <sub>16</sub>
(30) Prescaler X (PREX)	0024 <sub>16</sub>	FF <sub>16</sub>	(63) Port P3 pull-up control register (PULL3)	0FF3 <sub>16</sub>	00 <sub>16</sub>
(31) Timer X (TX)	0025 <sub>16</sub>	FF <sub>16</sub>	(64) Port P4 pull-up control register (PULL4)	0FF4 <sub>16</sub>	00 <sub>16</sub>
(32) Prescaler Y (PREY)	0026 <sub>16</sub>	FF <sub>16</sub>	(65) Port P5 pull-up control register (PULL5)	0FF5 <sub>16</sub>	00 <sub>16</sub>
(33) Timer Y (TY)	0027 <sub>16</sub>	FF <sub>16</sub>	(66) Port P6 pull-up control register (PULL6)	0FF6 <sub>16</sub>	00 <sub>16</sub>
			(67) Processor status register (PS)	X X X X X 1 X X	
			(68) Program counter (PC <sub>H</sub> )	FFFD <sub>16</sub> contents	
			(PC <sub>L</sub> )	FFFC <sub>16</sub> contents	

**Note :** X : Not fixed  
Since the initial values for other than above mentioned registers and RAM contents are indefinite at reset, they must be set.

Fig. 59 Internal status at reset

## CLOCK GENERATING CIRCUIT

The 3803 group (Spec. H) has two built-in oscillation circuits: main clock X<sub>IN</sub>-X<sub>OUT</sub> oscillation circuit and sub clock X<sub>CIN</sub>-X<sub>COU</sub>T oscillation circuit. An oscillation circuit can be formed by connecting a resonator between X<sub>IN</sub> and X<sub>OUT</sub> (X<sub>CIN</sub> and X<sub>COU</sub>T). Use the circuit constants in accordance with the resonator manufacturer's recommended values. No external resistor is needed between X<sub>IN</sub> and X<sub>OUT</sub> since a feed-back resistor exists on-chip. (An external feed-back resistor may be needed depending on conditions.) However, an external feed-back resistor is needed between X<sub>CIN</sub> and X<sub>COU</sub>T.

Immediately after power on, only the X<sub>IN</sub> oscillation circuit starts oscillating, and X<sub>CIN</sub> and X<sub>COU</sub>T pins function as I/O ports.

### Frequency Control

#### (1) Middle-speed mode

The internal clock  $\phi$  is the frequency of X<sub>IN</sub> divided by 8. After reset is released, this mode is selected.

#### (2) High-speed mode

The internal clock  $\phi$  is half the frequency of X<sub>IN</sub>.

#### (3) Low-speed mode

The internal clock  $\phi$  is half the frequency of X<sub>CIN</sub>.

#### (4) Low power dissipation mode

The low power consumption operation can be realized by stopping the main clock X<sub>IN</sub> in low-speed mode. To stop the main clock, set bit 5 of the CPU mode register to "1." When the main clock X<sub>IN</sub> is restarted (by setting the main clock stop bit to "0"), set sufficient time for oscillation to stabilize.

## Oscillation Control

### (1) Stop mode

If the STP instruction is executed, the internal clock  $\phi$  stops at an "H" level, and X<sub>IN</sub> and X<sub>CIN</sub> oscillators stop. When the oscillation stabilizing time set after STP instruction released bit is "0," the prescaler 12 is set to "FF16" and timer 1 is set to "0116." When the oscillation stabilizing time set after STP instruction released bit is "1," set the sufficient time for oscillation of used oscillator to stabilize since nothing is set to the prescaler 12 and timer 1.

After STP instruction is released, the input of the prescaler 12 is connected to count source which had set at executing the STP instruction, and the output of the prescaler 12 is connected to timer 1. Set the timer 1 interrupt enable bit to disabled ("0") before executing the STP instruction. Oscillator restarts when an external interrupt is received, but the internal clock  $\phi$  is not supplied to the CPU (remains at "H") until timer 1 underflows. The internal clock  $\phi$  is supplied for the first time, when timer 1 underflows. Therefore make sure not to set the timer 1 interrupt request bit to "1" before the STP instruction stops the oscillator. When the oscillator is restarted by reset, apply "L" level to the RESET pin until the oscillation is stable since a wait time will not be generated.

With the flash memory version, the internal power supply circuit is changed to low power consumption mode for consumption current reduction at the time of STP instruction execution.

Although an internal power supply circuit is usually changed to the normal operation mode at the time of the return from an STP instruction, since a certain time is required to start the power supply to the flash memory and operation of flash memory to be enabled, set wait time 100  $\mu$ s or more with the flash memory version by the oscillation stabilization time set function after release of the STP instruction which used the timer 1.

### (2) Wait mode

If the WIT instruction is executed, the internal clock  $\phi$  stops at an "H" level, but the oscillator does not stop. The internal clock  $\phi$  restarts when an interrupt is received. Since the oscillator does not stop, normal operation can be started immediately after the clock is restarted.

#### ■Note

- If you switch the mode between middle/high-speed and low-speed, stabilize both X<sub>IN</sub> and X<sub>CIN</sub> oscillations. The sufficient time is required for the sub clock to stabilize, especially immediately after power on and at returning from stop mode. When switching the mode between middle/high-speed and low-speed, set the frequency on condition that  $f(X_{IN}) > 3f(X_{CIN})$ .
- When using the quartz-crystal oscillator of high frequency, such as 16 MHz etc., it may be necessary to select a specific oscillator with the specification demanded.



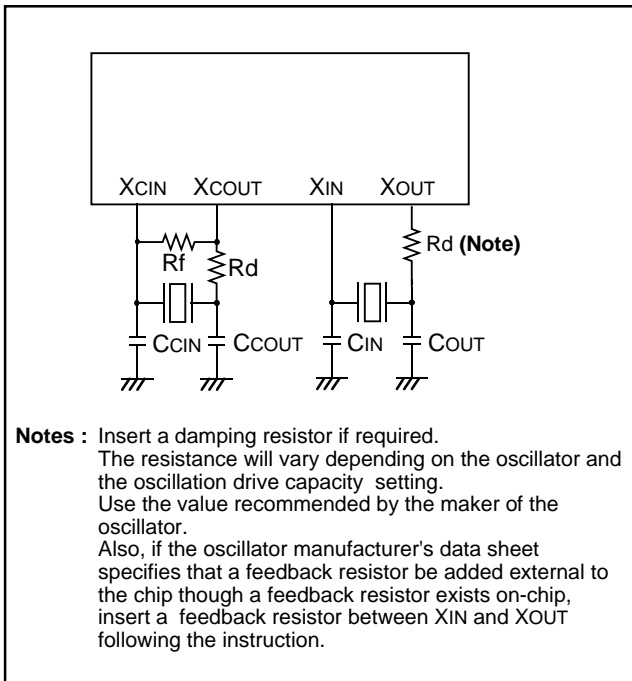

Fig. 60 Ceramic resonator circuit

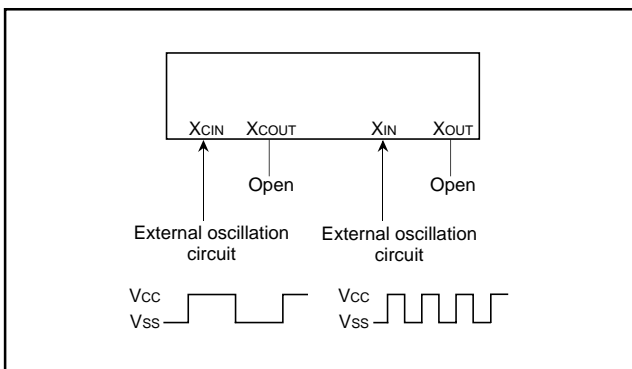

Fig. 61 External clock input circuit



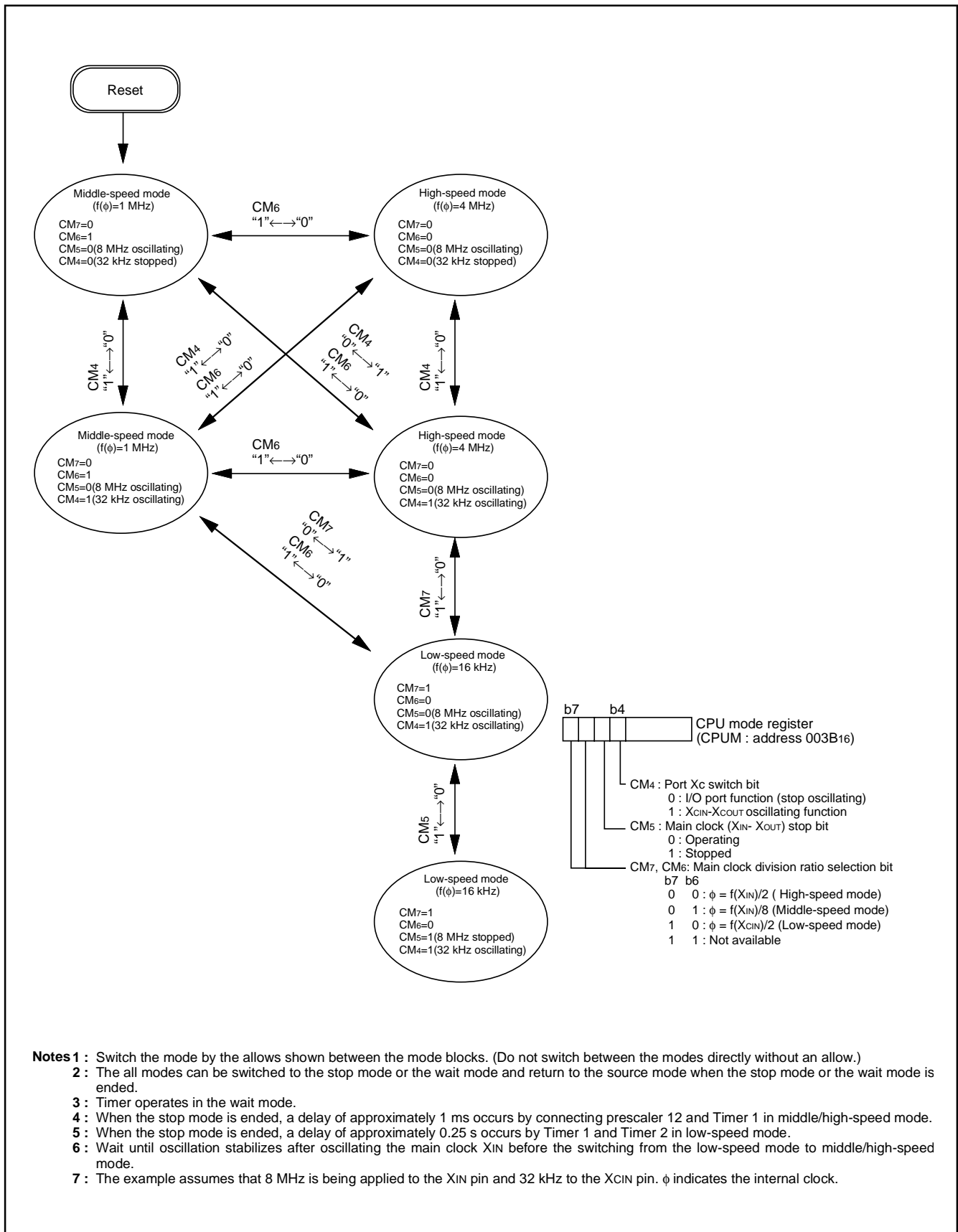

Fig. 63 State transitions of system clock

- Notes 1 :** Switch the mode by the allows shown between the mode blocks. (Do not switch between the modes directly without an allow.)  
**2 :** The all modes can be switched to the stop mode or the wait mode and return to the source mode when the stop mode or the wait mode is ended.  
**3 :** Timer operates in the wait mode.  
**4 :** When the stop mode is ended, a delay of approximately 1 ms occurs by connecting prescaler 12 and Timer 1 in middle/high-speed mode.  
**5 :** When the stop mode is ended, a delay of approximately 0.25 s occurs by Timer 1 and Timer 2 in low-speed mode.  
**6 :** Wait until oscillation stabilizes after oscillating the main clock XIN before the switching from the low-speed mode to middle/high-speed mode.  
**7 :** The example assumes that 8 MHz is being applied to the XIN pin and 32 kHz to the XCIN pin. φ indicates the internal clock.

## FLASH MEMORY MODE

The 3803 group (spec. H)'s flash memory version has the flash memory that can be rewritten with a single power source.

For this flash memory, three flash memory modes are available in which to read, program, and erase: the parallel I/O and standard serial I/O modes in which the flash memory can be manipulated using a programmer and the CPU rewrite mode in which the flash memory can be manipulated by the Central Processing Unit (CPU).

This flash memory version has some blocks on the flash memory as shown in Figure 64 and each block can be erased.

In addition to the ordinary User ROM area to store the MCU operation control program, the flash memory has a Boot ROM area that is used to store a program to control rewriting in CPU rewrite and standard serial I/O modes. This Boot ROM area has had a standard serial I/O mode control program stored in it when shipped from the factory. However, the user can write a rewrite control program in this area that suits the user's application system. This Boot ROM area can be rewritten in only parallel I/O mode.

### ● Summary

Table 11 lists the summary of the 3803 Group (spec. H) flash memory version.

**Table 11 Summary of 3803 group (spec. H)'s flash memory version**

Item		Specifications
Power source voltage (Vcc)		VCC = 2.7 to 5.5 V
Program/Erase VPP voltage (VPP)		VCC = 2.7 to 5.5 V
Flash memory mode		3 modes; Parallel I/O mode, Standard serial I/O mode, CPU rewrite mode
Erase block division	User ROM area/Data ROM area	Refer to Fig. 64.
	Boot ROM area (Note)	Not divided (4K bytes)
Program method		In units of bytes
Erase method		Block erase
Program/Erase control method		Program/Erase control by software command
Number of commands		5 commands
Number of program/Erase times		100
ROM code protection		Available in parallel I/O mode and standard serial I/O mode

**Note:** The Boot ROM area has had a standard serial I/O mode control program stored in it when shipped from the factory.  
This Boot ROM area can be erased and written in only parallel I/O mode.

## ● Boot Mode

The control program for CPU rewrite mode must be written into the User ROM or Boot ROM area in parallel I/O mode beforehand. (If the control program is written into the Boot ROM area, the standard serial I/O mode becomes unusable.)

See Figure 64 for details about the Boot ROM area.

Normal microcomputer mode is entered when the microcomputer is reset with pulling CNVss pin low. In this case, the CPU starts operating using the control program in the User ROM area.

When the microcomputer is reset and the CNVss pin high after pulling the P45/TxD1 pin and CNVss pin high, the CPU starts operating (start address of program is stored into addresses FFFC<sub>16</sub> and FFFD<sub>16</sub>) using the control program in the Boot ROM area. This mode is called the "Boot mode". Also, User ROM area can be rewritten using the control program in the Boot ROM area.

## ● Block Address

Block addresses refer to the maximum address of each block. These addresses are used in the block erase command.

## ● CPU Rewrite Mode

In CPU rewrite mode, the internal flash memory can be operated on (read, program, or erase) under control of the Central Processing Unit (CPU).

In CPU rewrite mode, only the User ROM area shown in Figure 64 can be rewritten; the Boot ROM area cannot be rewritten. Make sure the program and block erase commands are issued for only the User ROM area and each block area.

The control program for CPU rewrite mode can be stored in either User ROM or Boot ROM area. In the CPU rewrite mode, because the flash memory cannot be read from the CPU, the rewrite control program must be transferred to internal RAM area before it can be executed.

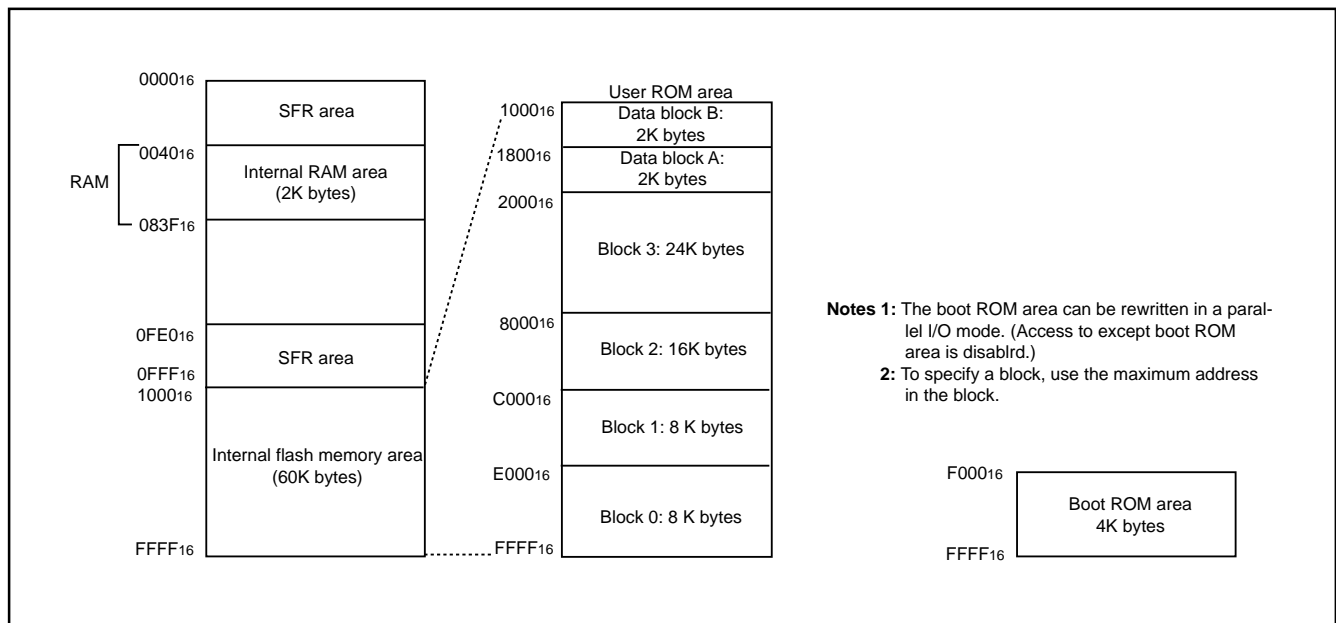

Fig. 64 Block diagram of built-in flash memory

## ●Outline Performance

CPU rewrite mode is usable in the single-chip or Boot mode. The only User ROM area can be rewritten.

In CPU rewrite mode, the CPU erases, programs and reads the internal flash memory as instructed by software commands. This rewrite control program must be transferred to internal RAM area before it can be executed.

The MCU enters CPU rewrite mode by setting "1" to the CPU rewrite mode select bit (bit 1 of address 0FE016). Then, software commands can be accepted.

Use software commands to control program and erase operations. Whether a program or erase operation has terminated normally or in error can be verified by reading the status register.

Figure 65 shows the flash memory control register 0.

Bit 0 of the flash memory control register 0 is the RY/BY status flag used exclusively to read the operating status of the flash memory. During programming and erase operations, it is "0" (busy). Otherwise, it is "1" (ready).

Bit 1 of the flash memory control register 0 is the CPU rewrite mode select bit. When this bit is set to "1", the MCU enters CPU rewrite mode. And then, software commands can be accepted. In CPU rewrite mode, the CPU becomes unable to access the internal flash memory directly. Therefore, use the control program in the internal RAM for write to bit 1. To set this bit 1 to "1", it is necessary to write "0" and then write "1" in succession to bit 1. The bit can be set to "0" by only writing "0".

Bit 2 of the flash memory control register 0 is the 8 KB user block E/W enable bit. By setting combination of bit 4 of the flash memory control register 2 and this bit as shown in Table 12, E/W is disabled to user block in the CPU rewriting mode.

Bit 3 of the flash memory control register 0 is the flash memory reset bit used to reset the control circuit of internal flash memory. This bit is used when flash memory access has failed. When the CPU rewrite mode select bit is "1", setting "1" for this bit resets the control circuit. To release the reset, it is necessary to set this bit to "0".

Bit 5 of the flash memory control register 0 is the User ROM area select bit and is valid only in the boot mode. Setting this bit to "1" in the boot mode switches an accessible area from the boot ROM area to the user ROM area. To use the CPU rewrite mode in the boot mode, set this bit to "1". To rewrite bit 5, execute the user-original reprogramming control software transferred to the internal RAM in advance.

Bit 6 of the flash memory control register 0 is the program status flag. This bit is set to "1" when writing to flash memory is failed. When program error occurs, the block cannot be used.

Bit 7 of the flash memory control register 0 is the erase status flag. This bit is set to "1" when erasing flash memory is failed. When erase error occurs, the block cannot be used.

Figure 66 shows the flash memory control register 1.

Bit 0 of the flash memory control register 1 is the Erase suspend enable bit. By setting this bit to "1", the erase suspend mode to suspend erase processing temporarily when block erase command is executed can be used. In order to set this bit to "1", writing "0" and "1" in succession to bit 0. In order to set this bit to "0", write "0" only to bit 0.

Bit 1 of the flash memory control register 1 is the erase suspend request bit. By setting this bit to "1" when erase suspend enable bit is "1", the erase processing is suspended.

Bit 6 of the flash memory control register 1 is the erase suspend flag. This bit is cleared to "0" at the flash erasing.

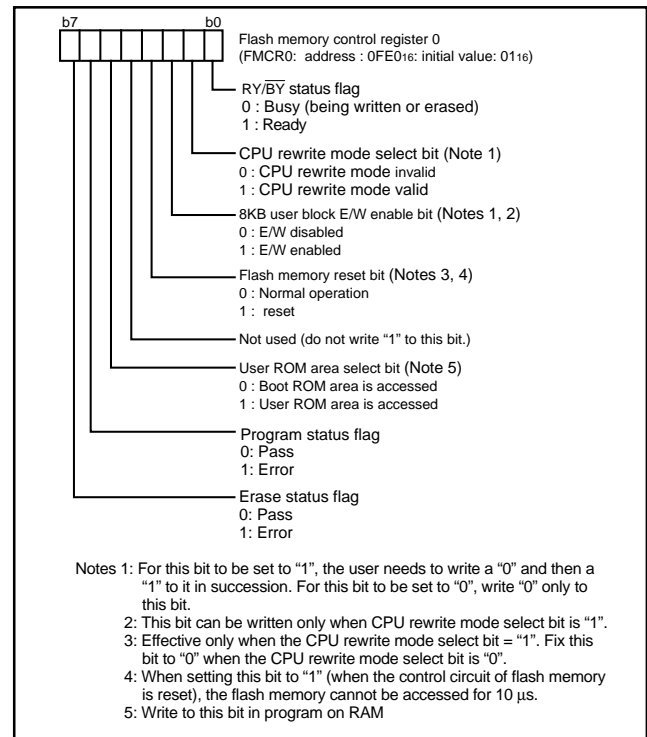

Fig. 65 Structure of flash memory control register 0

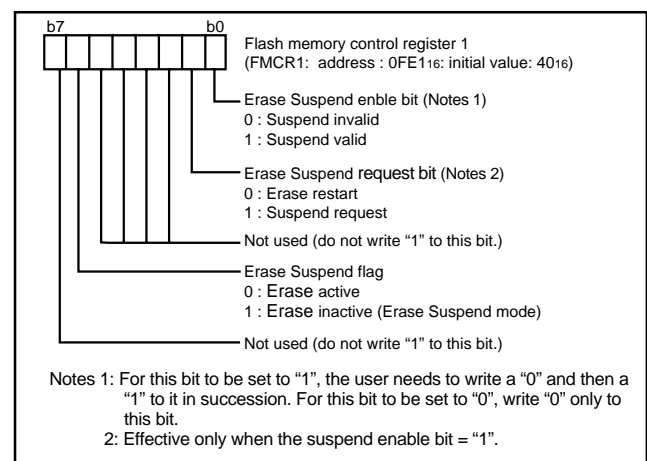

Fig. 66 Structure of flash memory control register 1

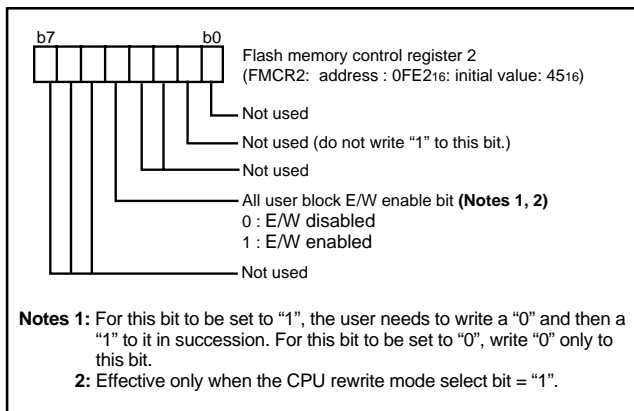

Fig. 67 Structure of flash memory control register 2

Table 12 State of E/W inhibition function

All user block E/W enable bit	8 KB user block E/W enable bit	8 KB X 2 block Addresses C000 <sub>16</sub> to FFFF <sub>16</sub>	16 KB + 24 KB block Addresses 2000 <sub>16</sub> to BFFF <sub>16</sub>	Data block Addresses 1000 <sub>16</sub> to 1FFF <sub>16</sub>
0	0	E/W disabled	E/W disabled	E/W enabled
0	1	E/W disabled	E/W disabled	E/W enabled
1	0	E/W disabled	E/W enabled	E/W enabled
1	1	E/W enabled	E/W enabled	E/W enabled

Figure 68 shows a flowchart for setting/releasing CPU rewrite mode.

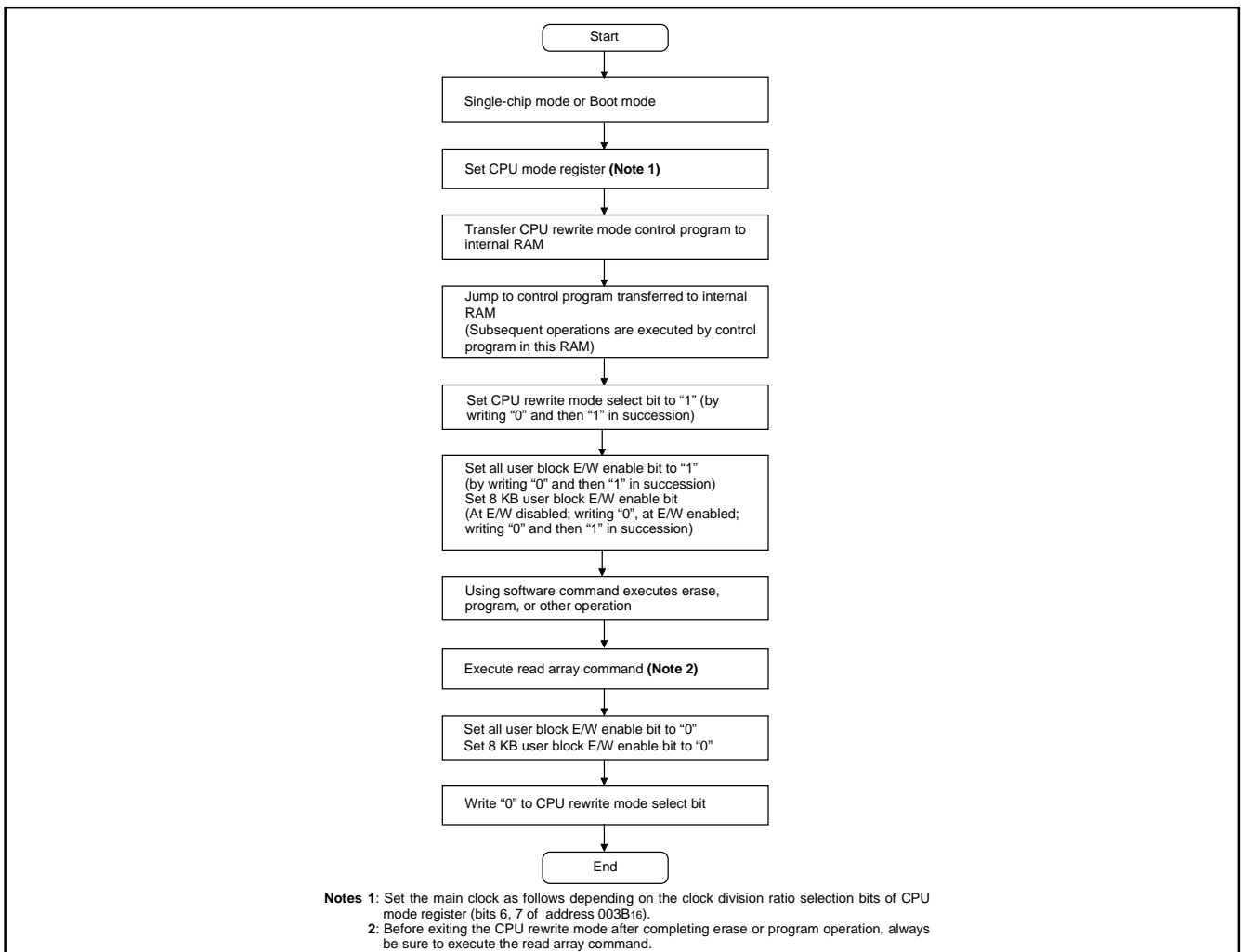

Fig. 68 CPU rewrite mode set/release flowchart

## ■ Notes on CPU Rewrite Mode

Take the notes described below when rewriting the flash memory in CPU rewrite mode.

### ● Operation speed

During CPU rewrite mode, set the system clock  $\phi$  to 4.0 MHz or less using the clock division ratio selection bits (bits 6 and 7 of address 003B<sub>16</sub>).

### ● Instructions inhibited against use

The instructions which refer to the internal data of the flash memory cannot be used during CPU rewrite mode.

### ● Interrupts

The interrupts cannot be used during CPU rewrite mode because they refer to the internal data of the flash memory.

### ● Watchdog timer

If the watchdog timer has been already activated, internal reset due to an underflow will not occur because the watchdog timer is surely cleared during program or erase.

### ● Reset

Reset is always valid. The MCU is activated using the boot mode at release of reset in the condition of CNV<sub>ss</sub> = "H", so that the program will begin at the address which is stored in addresses FFFC<sub>16</sub> and FFFD<sub>16</sub> of the boot ROM area.



● Software Commands

Table 13 lists the software commands.

After setting the CPU rewrite mode select bit to "1", execute a software command to specify an erase or program operation. Each software command is explained below.

• Read Array Command (FF16)

The read array mode is entered by writing the command code "FF16" in the first bus cycle. When an address to be read is input in one of the bus cycles that follow, the contents of the specified address are read out at the data bus (D0 to D7). The read array mode is retained until another command is written.

• Read Status Register Command (7016)

When the command code "7016" is written in the first bus cycle, the contents of the status register are read out at the data bus (D0 to D7) by a read in the second bus cycle. The status register is explained in the next section.

• Clear Status Register Command (5016)

This command is used to clear the bits SR4 and SR5 of the status register after they have been set. These bits indicate that operation has ended in an error. To use this command, write the command code "5016" in the first bus cycle.

• Program Command (4016)

Program operation starts when the command code "4016" is written in the first bus cycle. Then, if the address and data to program are written in the 2nd bus cycle, program operation (data programming and verification) will start.

Whether the write operation is completed can be confirmed by read status register or the RY/BY status flag. When the program starts, the read status register mode is entered automatically and the contents of the status register is read at the data bus (D0 to D7). The status register bit 7 (SR7) is set to "0" at the same time the write operation starts and is returned to "1" upon completion of the write operation. In this case, the read status register mode remains active until the read array command (FF16) is written.

The RY/BY status flag of the flash memory control register is "0" during write operation and "1" when the write operation is completed as is the status register bit 7.

At program end, program results can be checked by reading the status register.

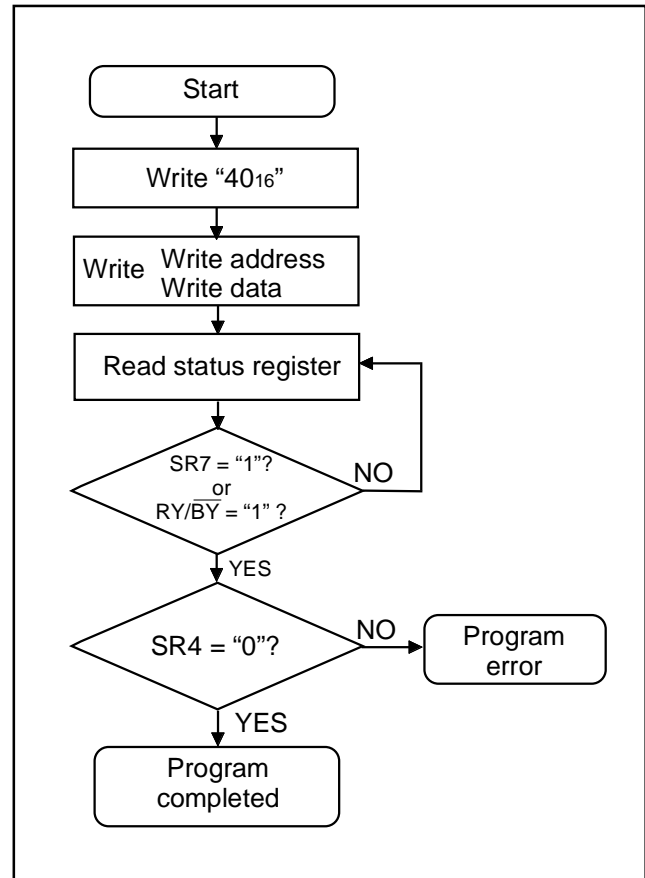

Fig. 69 Program flowchart

Table 13 List of software commands (CPU rewrite mode)

Command	Cycle number	First bus cycle			Second bus cycle		
		Mode	Address	Data (D0 to D7)	Mode	Address	Data (D0 to D7)
Read array	1	Write	X (Note 4)	FF16			
Read status register	2	Write	X	7016	Read	X	SRD (Note 1)
Clear status register	1	Write	X	5016			
Program	2	Write	X	4016	Write	WA (Note 2)	WD (Note 2)
Block erase	2	Write	X	2016	Write	BA (Note 3)	D016

Notes 1: SRD = Status Register Data

2: WA = Write Address, WD = Write Data

3: BA = Block Address to be erased (Input the maximum address of each block.)

4: X denotes a given address in the User ROM area.

#### • Block Erase Command (20<sub>16</sub>/D0<sub>16</sub>)

By writing the command code "20<sub>16</sub>" in the first bus cycle and the confirmation command code "D0<sub>16</sub>" and the block address in the second bus cycle that follows, the block erase (erase and erase verify) operation starts for the block address of the flash memory to be specified.

Whether the block erase operation is completed can be confirmed by read status register or the RY/ $\overline{\text{BY}}$  status flag of flash memory control register. At the same time the block erase operation starts, the read status register mode is automatically entered, so that the contents of the status register can be read out. The status register bit 7 (SR7) is set to "0" at the same time the block erase operation starts and is returned to "1" upon completion of the block erase operation. In this case, the read status register mode remains active until the read array command (FF<sub>16</sub>) is written.

The RY/ $\overline{\text{BY}}$  status flag is "0" during block erase operation and "1" when the block erase operation is completed as is the status register bit 7.

After the block erase ends, erase results can be checked by reading the status register. For details, refer to the section where the status register is detailed.

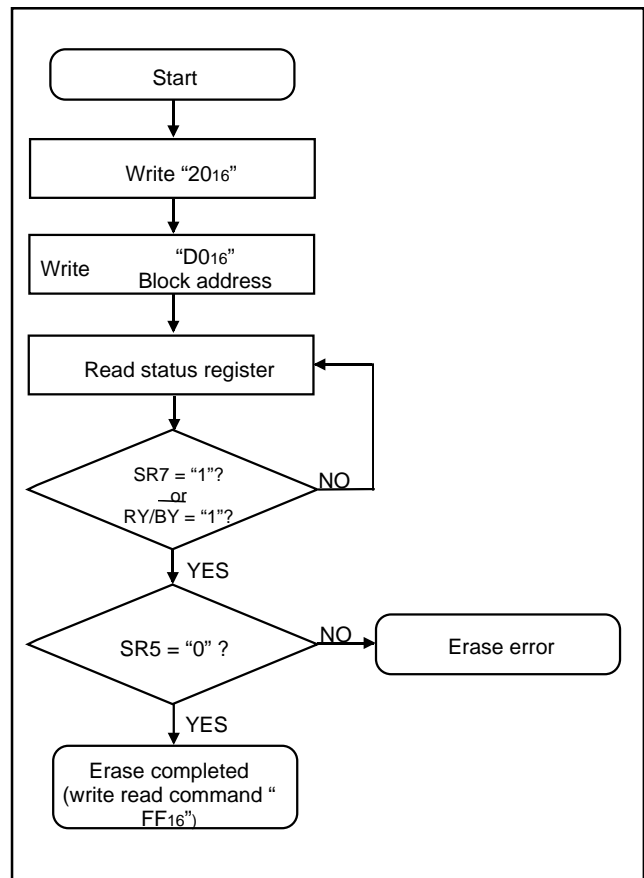

Fig. 70 Erase flowchart

## ● Status Register

The status register shows the operating status of the flash memory and whether erase operations and programs ended successfully or in error. It can be read in the following ways:

- (1) By reading an arbitrary address from the User ROM area after writing the read status register command (70<sub>16</sub>)
- (2) By reading an arbitrary address from the User ROM area in the period from when the program starts or erase operation starts to when the read array command (FF<sub>16</sub>) is input.

Also, the status register can be cleared by writing the clear status register command (50<sub>16</sub>).

After reset, the status register is set to "80<sub>16</sub>".

Table 14 shows the status register. Each bit in this register is explained below.

### •Sequencer status (SR7)

The sequencer status indicates the operating status of the flash memory. This bit is set to "0" (busy) during write or erase operation and is set to "1" when these operations ends.

After power-on, the sequencer status is set to "1" (ready).

### •Erase status (SR5)

The erase status indicates the operating status of erase operation. If an erase error occurs, it is set to "1". When the erase status is cleared, it is reset to "0".

### •Program status (SR4)

The program status indicates the operating status of write operation. When a write error occurs, it is set to "1".

The program status is reset to "0" when it is cleared.

If "1" is written for any of the SR5 and SR4 bits, the read array, program, and block erase commands are not accepted. Before executing these commands, execute the clear status register command (50<sub>16</sub>) and clear the status register.

Also, if any commands are not correct, both SR5 and SR4 are set to "1".

**Table 14 Definition of each bit in status register**

Each bit of SRD bits	Status name	Definition	
		"1"	"0"
SR7 (bit7)	Sequencer status	Ready	Busy
SR6 (bit6)	Reserved	-	-
SR5 (bit5)	Erase status	Terminated in error	Terminated normally
SR4 (bit4)	Program status	Terminated in error	Terminated normally
SR3 (bit3)	Reserved	-	-
SR2 (bit2)	Reserved	-	-
SR1 (bit1)	Reserved	-	-
SR0 (bit0)	Reserved	-	-

## ● Full Status Check

By performing full status check, it is possible to know the execution results of erase and program operations. Figure 71 shows a full status check flowchart and the action to be taken when each error occurs.

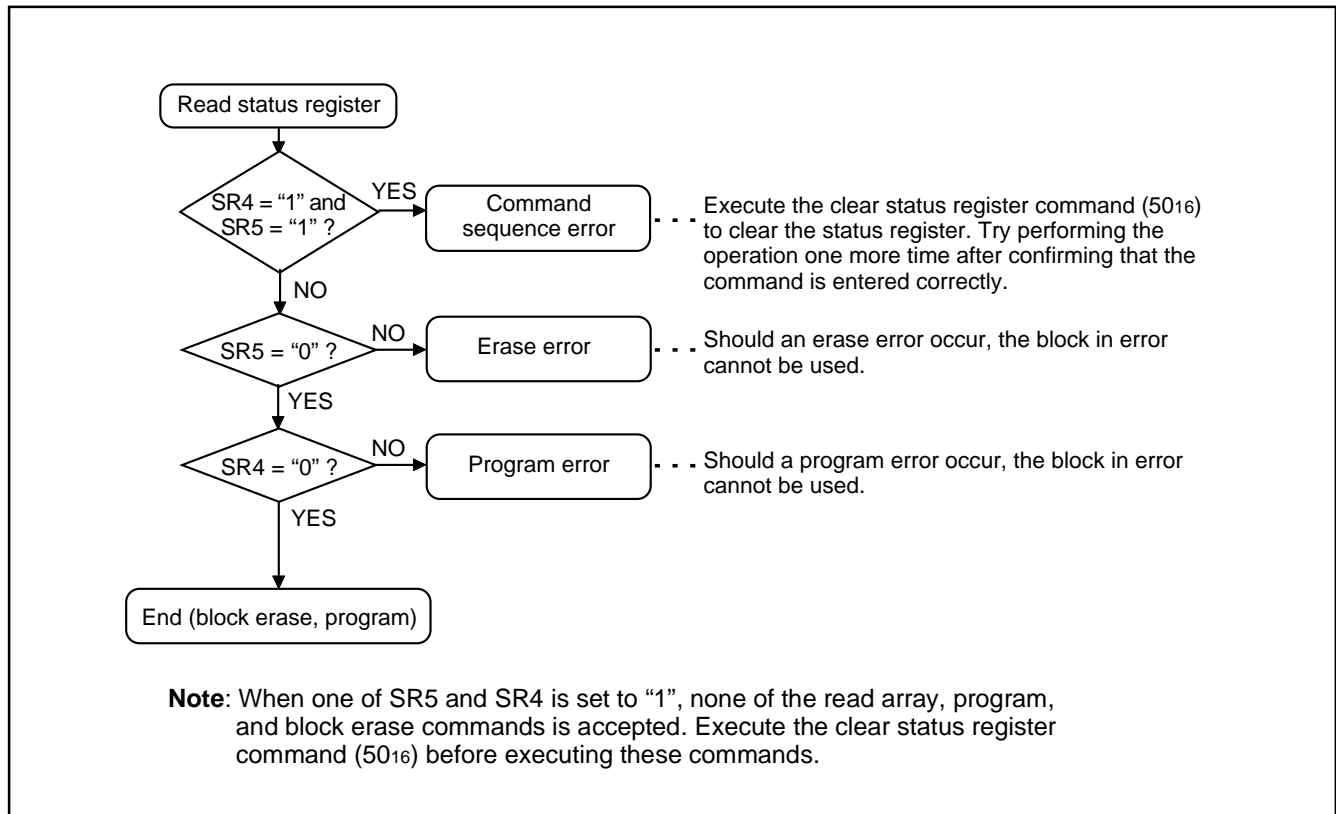

Fig. 71 Full status check flowchart and remedial procedure for errors

## ● Functions To Inhibit Rewriting Flash Memory Version

To prevent the contents of internal flash memory from being read out or rewritten easily, this MCU incorporates a ROM code protect function for use in parallel I/O mode and an ID code check function for use in standard serial I/O mode.

### (1) ROM Code Protect Function

The ROM code protect function is the function to inhibit reading out or modifying the contents of internal flash memory by using the ROM code protect control address (address FFDB<sub>16</sub>) in parallel I/O mode. Figure 72 shows the ROM code protect control address (address FFDB<sub>16</sub>). (This address exists in the User ROM area.)

If one or both of the pair of ROM code protect bits is set to "0", the ROM code protect is turned on, so that the contents of internal flash memory are protected against readout and modification. The ROM code protect is implemented in two levels. If level 2 is selected, the flash memory is protected even against readout by a shipment inspection LSI tester, etc. When an attempt is made to select both level 1 and level 2, level 2 is selected by default.

If both of the two ROM code protect reset bits are set to "00", the ROM code protect is turned off, so that the contents of internal flash memory can be readout or modified. Once the ROM code protect is turned on, the contents of the ROM code protect reset bits cannot be modified in parallel I/O mode. Use the serial I/O or CPU rewrite mode to rewrite the contents of the ROM code protect reset bits.

Rewriting of only the ROM code protect control address (address FFDB<sub>16</sub>) cannot be performed. When rewriting the ROM code protect reset bit, rewrite the whole user ROM area (block 0) containing the ROM code protect control address.

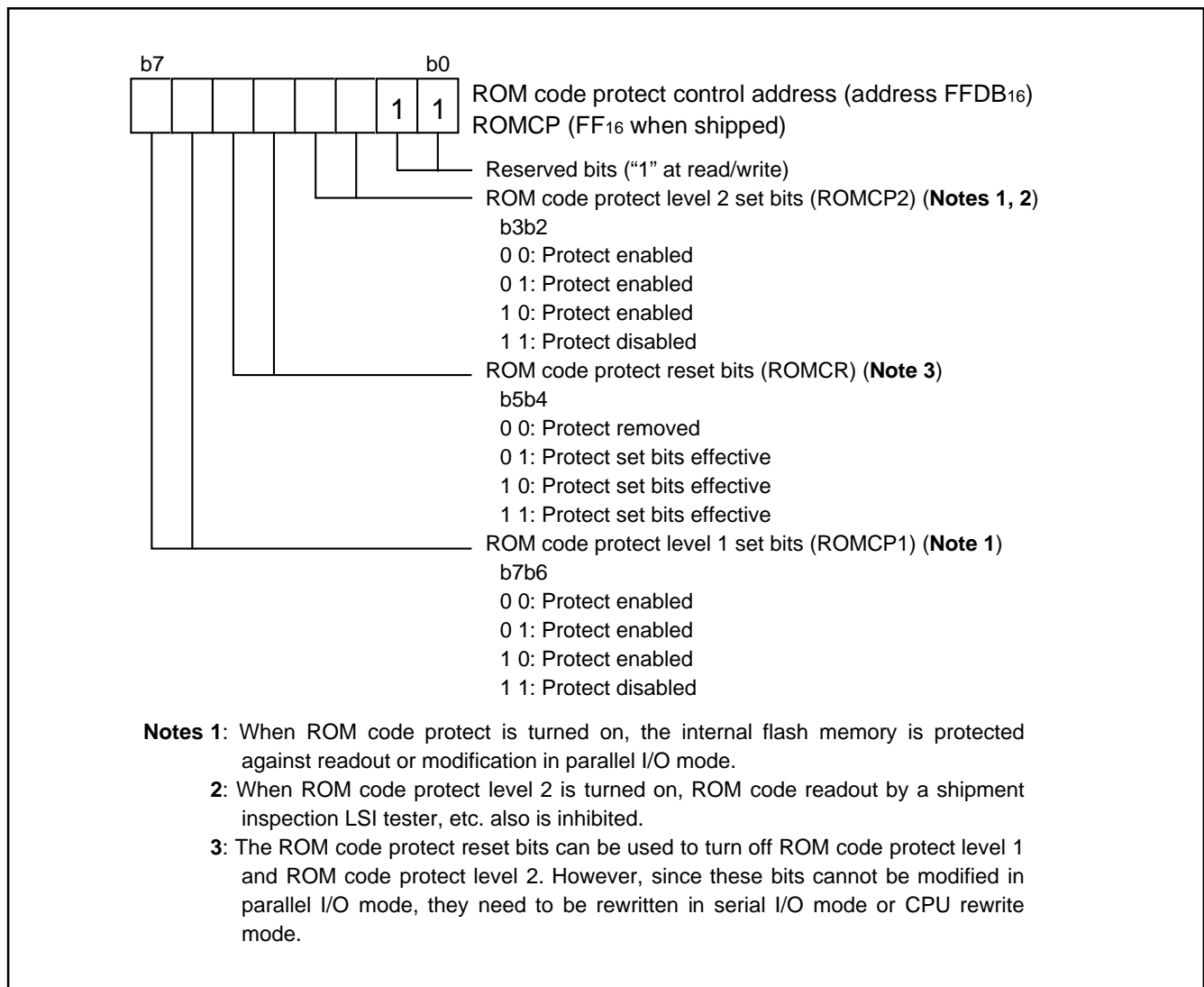
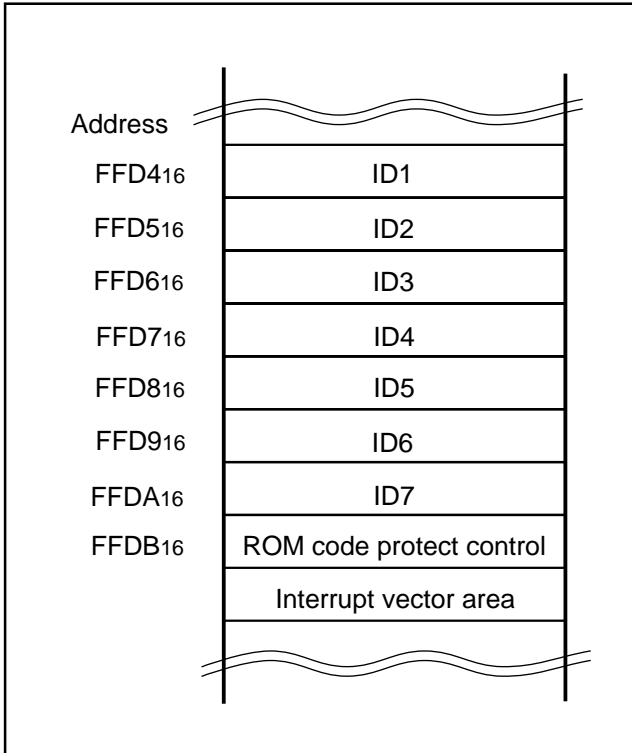

Fig. 72 Structure of ROM code protect control address

**(2) ID Code Check Function**

Use this function in standard serial I/O mode. When the contents of the flash memory are not blank, the ID code sent from the programmer is compared with the ID code written in the flash memory to see if they match. If the ID codes do not match, the commands sent from the programmer are not accepted. The ID code consists of 8-bit data, and its areas are FFD4<sub>16</sub> to FFDA<sub>16</sub>. Write a program which has had the ID code preset at these addresses to the flash memory.

**Fig. 73 ID code store addresses**

**● Parallel I/O Mode**

The parallel I/O mode is used to input/output software commands, address and data in parallel for operation (read, program and erase) to internal flash memory.

Use the external device (writer) only for 3803 Group (spec. H) flash memory version. For details, refer to the user's manual of each writer manufacturer.

**• User ROM and Boot ROM Areas**

In parallel I/O mode, the User ROM and Boot ROM areas shown in Figure 64 can be rewritten. Both areas of flash memory can be operated on in the same way.

The Boot ROM area is 4 Kbytes in size and located at addresses F000<sub>16</sub> through FFFF<sub>16</sub>. Make sure program and block erase operations are always performed within this address range. (Access to any location outside this address range is prohibited.)

In the Boot ROM area, an erase block operation is applied to only one 4 Kbyte block. The boot ROM area has had a standard serial I/O mode control program stored in it when shipped from the factory. Therefore, using the MCU in standard serial I/O mode, do not rewrite to the Boot ROM area.

## ● Standard serial I/O Mode

The standard serial I/O mode inputs and outputs the software commands, addresses and data needed to operate (read, program, erase, etc.) the internal flash memory. This I/O is clock synchronized serial. This mode requires a purpose-specific peripheral unit.

The standard serial I/O mode is different from the parallel I/O mode in that the CPU controls flash memory rewrite (uses the CPU rewrite mode), rewrite data input and so forth. The standard serial I/O mode is started by connecting "H" to the CNVss pin and "H" to the P45 (BOOTENT) pin, and releasing the reset operation. (In the ordinary microcomputer mode, set CNVss pin to "L" level.) This control program is written in the Boot ROM area when the product is shipped from Renesas. Accordingly, make note of the fact that the standard serial I/O mode cannot be used if the Boot ROM area is rewritten in parallel I/O mode. The standard serial I/O mode has standard serial I/O mode 1 of the clock synchronous serial and standard serial I/O mode 2 of the clock asynchronous serial. Tables 15 and 16 show description of pin function (standard serial I/O mode). Figures 74 to 77 show the pin connections for the standard serial I/O mode.

In standard serial I/O mode, only the User ROM area shown in Figure 64 can be rewritten. The Boot ROM area cannot be written. In standard serial I/O mode, a 7-byte ID code is used. When there is data in the flash memory, this function determines whether the ID code sent from the peripheral unit (programmer) and those written in the flash memory match. The commands sent from the peripheral unit (programmer) are not accepted unless the ID code matches.



**Table 15 Description of pin function (Flash Memory Serial I/O Mode 1)**

Pin name	Signal name	I/O	Function
Vcc,Vss	Power supply	I	Apply 2.7 to 5.5 V to the Vcc pin and 0 V to the Vss pin.
CNVss	CNVss	I	After input of port is set, input "H" level.
RESET	Reset input	I	Reset input pin. To reset the microcomputer, RESET pin should be held at an "L" level for 16 cycles or more of XIN.
XIN	Clock input	I	Connect an oscillation circuit between the XIN and XOUT pins.
XOUT	Clock output	O	As for the connection method, refer to the "clock generating circuit".
AVss	Analog power supply input		Connect AVss to Vss.
VREF	Reference voltage input	I	Apply reference voltage of A-D to this pin.
P00–P07,P10–P17, P20–P27,P30–P37, P40–P43,P50–P57, P60–P67	I/O port	I/O	Input "L" or "H" level, or keep open.
P44	RxD input	I	Serial data input pin.
P45	TxD output	O	Serial data output pin.
P46	SCLK input	I	Serial clock input pin.
P47	BUSY output	O	BUSY signal output pin.

**Table 16 Description of pin function (Flash Memory Serial I/O Mode 2)**

Pin name	Signal name	I/O	Function
Vcc,Vss	Power supply	I	Apply 2.7 to 5.5 V to the Vcc pin and 0 V to the Vss pin.
CNVss	CNVss	I	After input of port is set, input "H" level.
RESET	Reset input	I	Reset input pin. To reset the microcomputer, RESET pin should be held at an "L" level for 16 cycles or more of XIN.
XIN	Clock input	I	Connect an oscillation circuit between the XIN and XOUT pins.
XOUT	Clock output	O	As for the connection method, refer to the "clock generating circuit".
AVss	Analog power supply input		Connect AVss to Vss.
VREF	Reference voltage input	I	Apply reference voltage of A-D to this pin.
P00–P07,P10–P17, P20–P27,P30–P37, P40–P43,P50–P57, P60–P67	I/O port	I/O	Input "L" or "H" level, or keep open.
P44	RxD input	I	Serial data input pin.
P45	TxD output	O	Serial data output pin.
P46	SCLK input	I	Input "L" level.
P47	BUSY output	O	BUSY signal output pin.

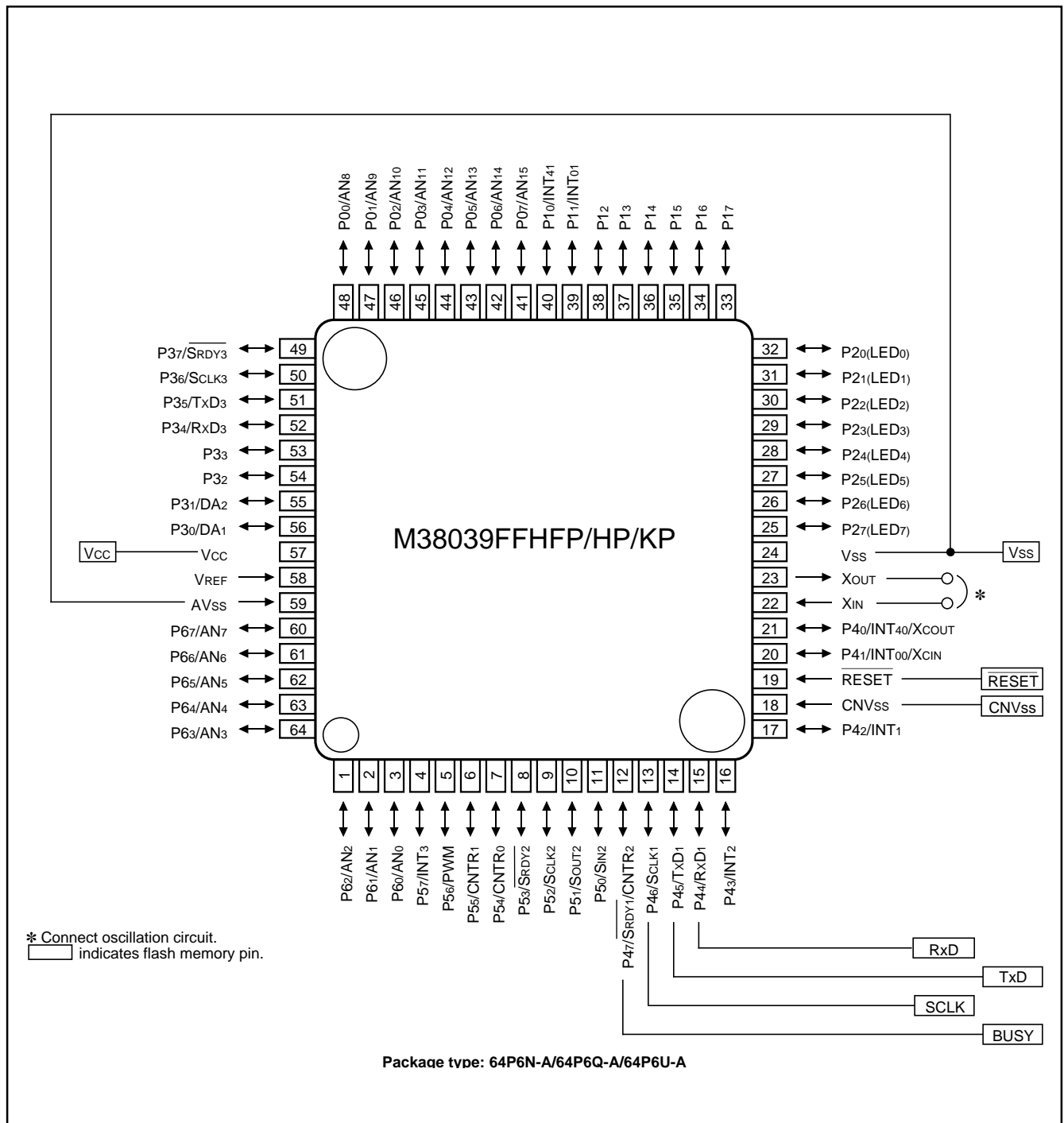

Fig. 74 Connection for standard serial I/O mode 1 (M38039FFHFP/HP/KP)

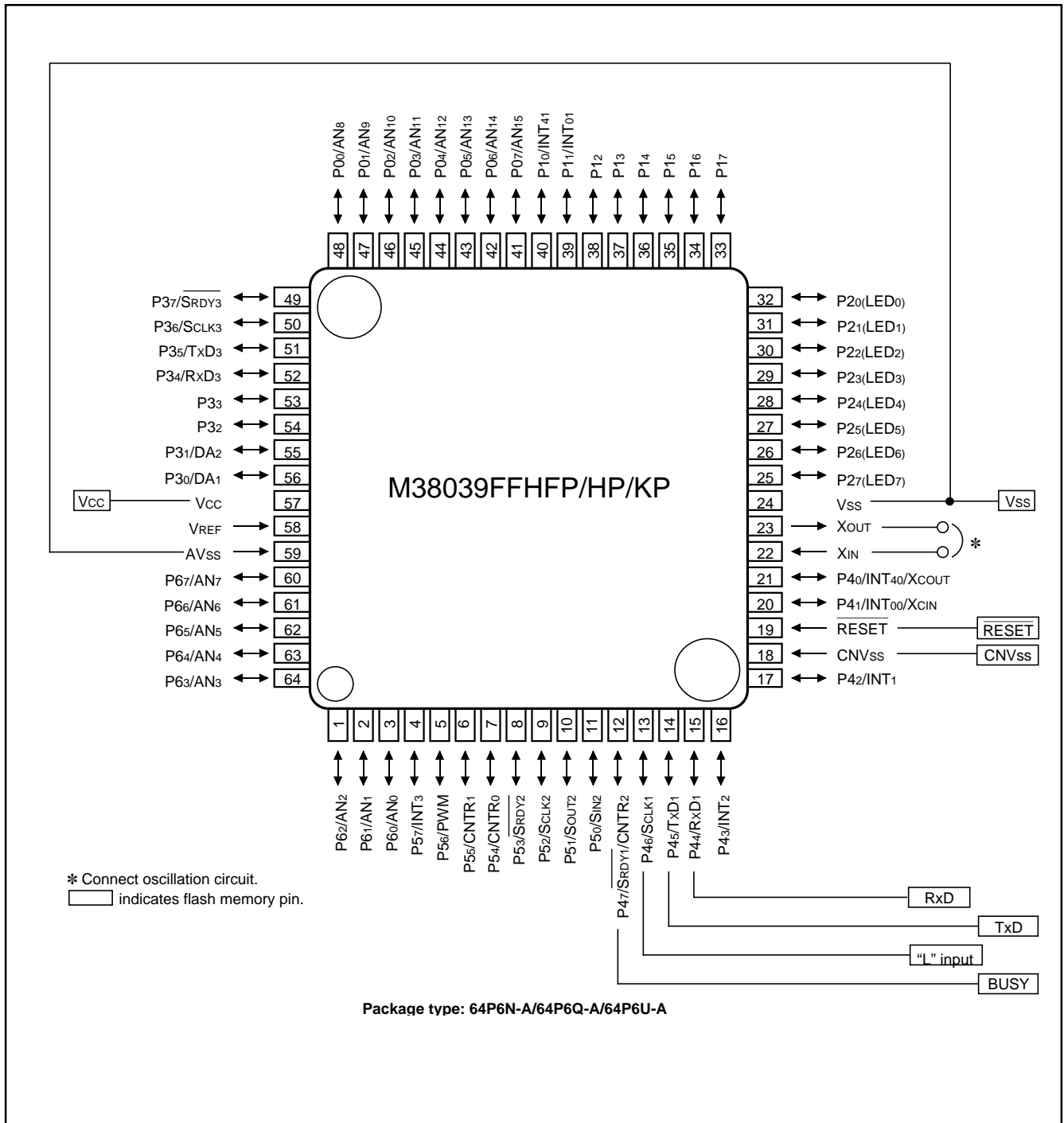

Fig. 75 Connection for standard serial I/O mode 2 (M38039FFHFP/HP/KP)

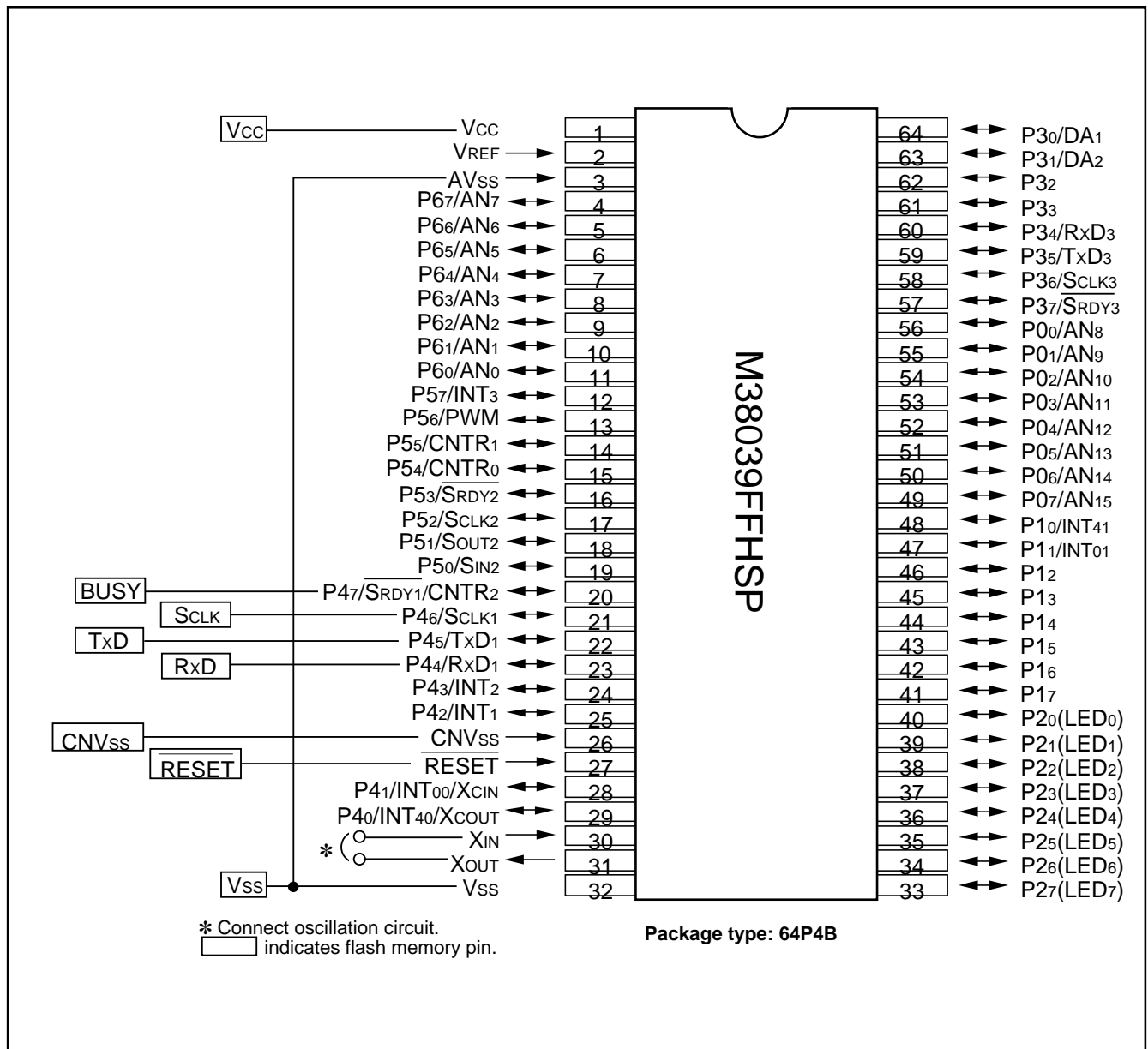

Fig. 76 Connection for standard serial I/O mode 1 (M38039FFHSP)

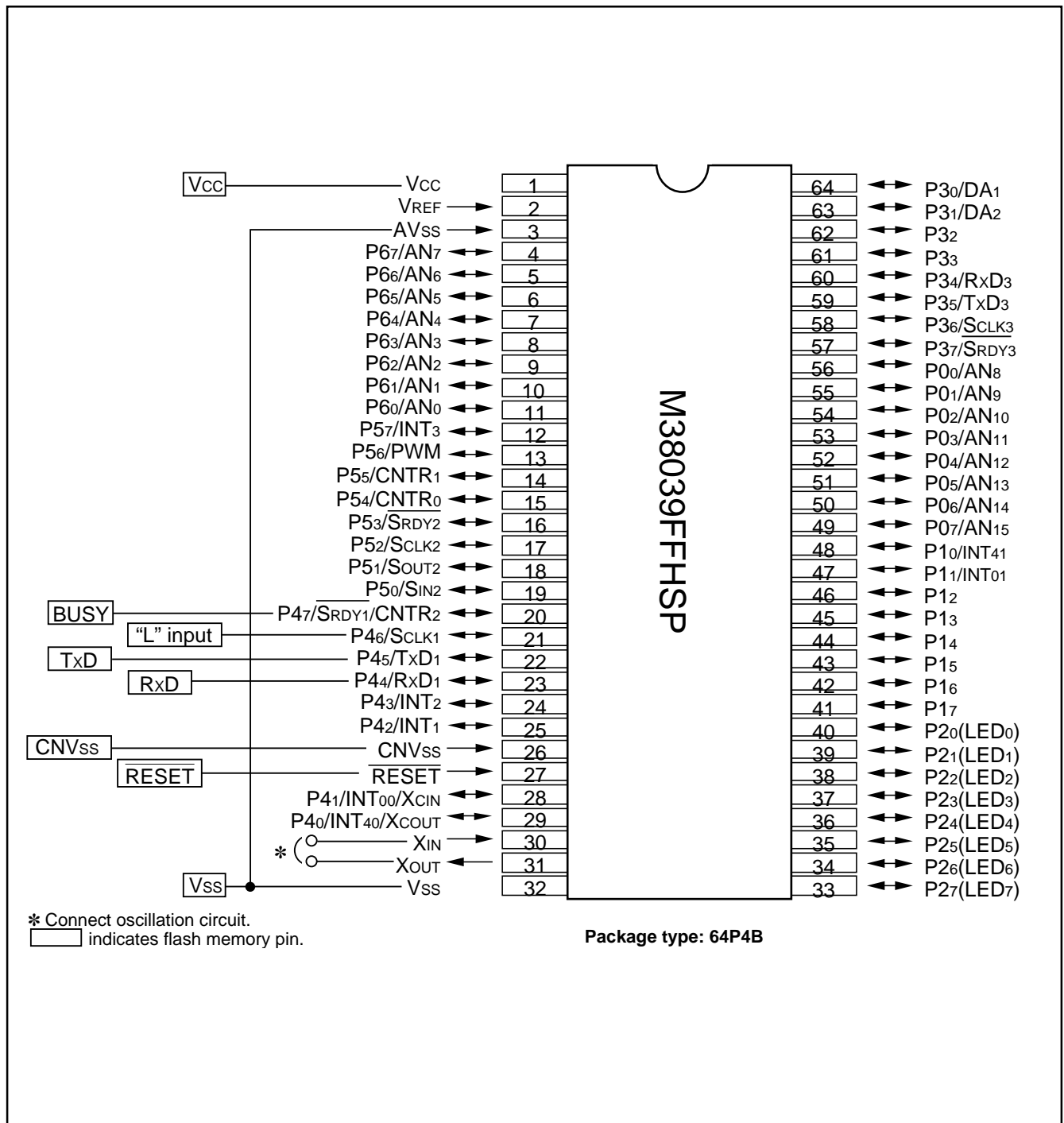

Fig. 77 Connection for standard serial I/O mode 2 (M38039FFHSP)

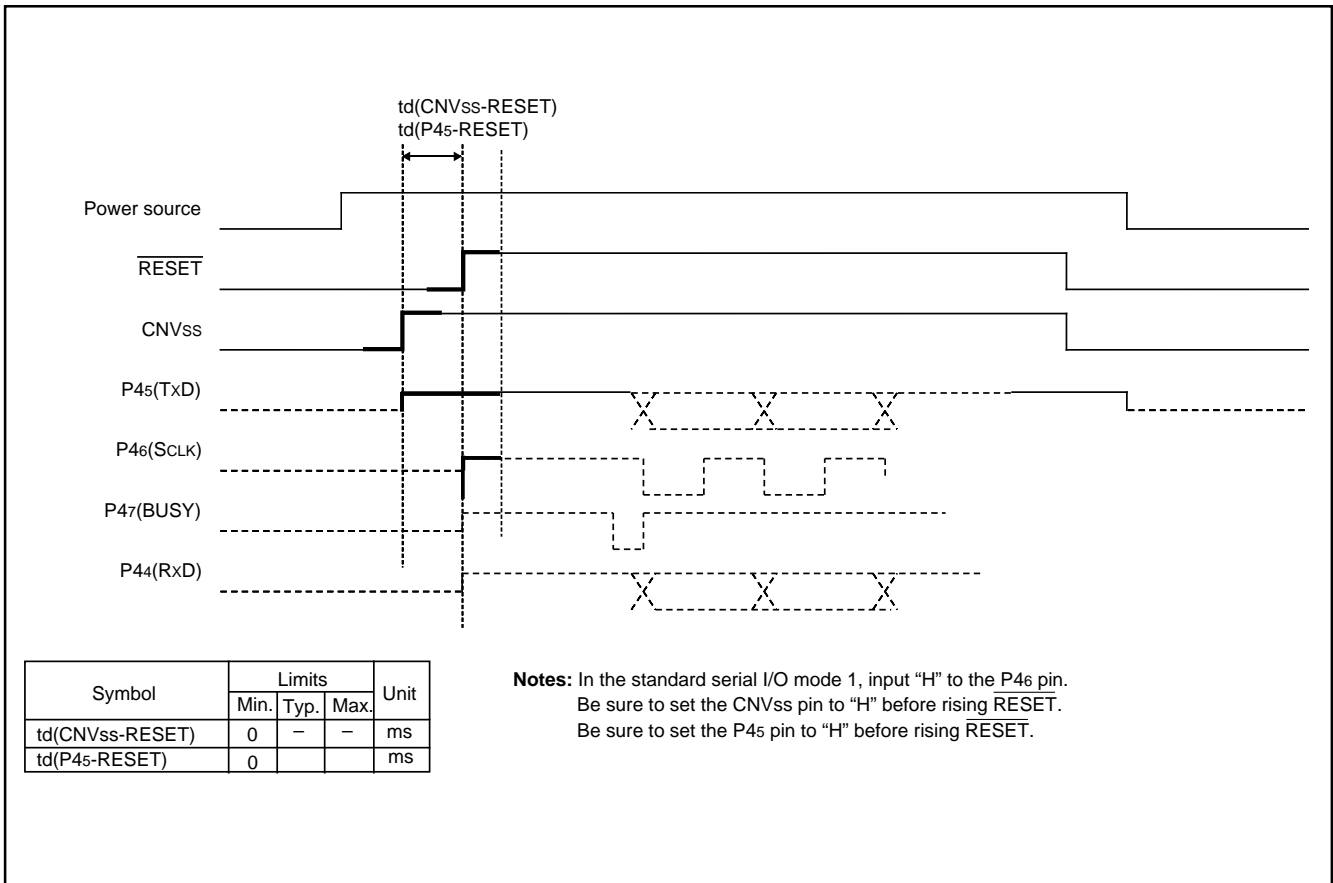

Fig. 78 Operating waveform for standard serial I/O mode 1

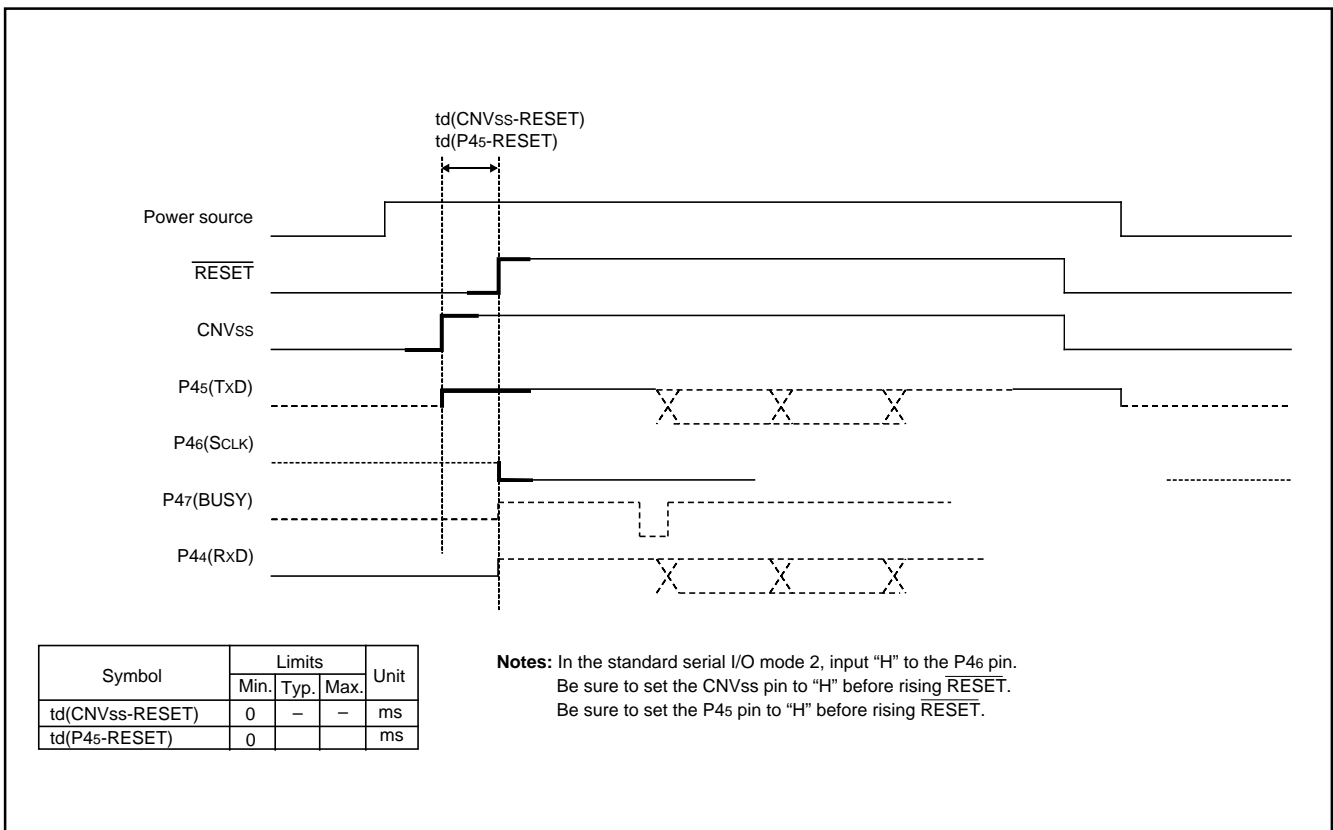

Fig. 79 Operating waveform for standard serial I/O mode 2

## NOTES ON PROGRAMMING

### Processor Status Register

The contents of the processor status register (PS) after a reset are undefined, except for the interrupt disable flag (I) which is "1." After a reset, initialize flags which affect program execution. In particular, it is essential to initialize the index X mode (T) and the decimal mode (D) flags because of their effect on calculations.

### Interrupts

The contents of the interrupt request bits do not change immediately after they have been written. After writing to an interrupt request register, execute at least one instruction before performing a BBC or BBS instruction.

### Decimal Calculations

- To calculate in decimal notation, set the decimal mode flag (D) to "1", then execute an ADC or SBC instruction. After executing an ADC or SBC instruction, execute at least one instruction before executing a SEC, CLC, or CLD instruction.
- In decimal mode, the values of the negative (N), overflow (V), and zero (Z) flags are invalid.

### Timers

If a value  $n$  (between 0 and 255) is written to a timer latch, the frequency division ratio is  $1/(n+1)$ .

### Multiplication and Division Instructions

- The index X mode (T) and the decimal mode (D) flags do not affect the MUL and DIV instruction.
- The execution of these instructions does not change the contents of the processor status register.

### Ports

The contents of the port direction registers cannot be read. The following cannot be used:

- The data transfer instruction (LDA, etc.)
- The operation instruction when the index X mode flag (T) is "1"
- The instruction with the addressing mode which uses the value of a direction register as an index
- The bit-test instruction (BBC or BBS, etc.) to a direction register
- The read-modify-write instructions (ROR, CLB, or SEB, etc.) to a direction register.

Use instructions such as LDM and STA, etc., to set the port direction registers.

### Serial I/O

In clock synchronous serial I/O, if the receive side is using an external clock and it is to output the  $\overline{\text{SRDY}}$  signal, set the transmit enable bit, the receive enable bit, and the  $\overline{\text{SRDY}}$  output enable bit to "1."

Serial I/O continues to output the final bit from the TxD pin after transmission is completed. SOUT2 pin for serial I/O2 goes to high impedance after transfer is completed.

When in serial I/Os 1 and 3 (clock-synchronous mode) or in serial I/O2, an external clock is used as synchronous clock, write transmission data to the transmit buffer register or serial I/O2 register, during transfer clock is "H."

### A-D Converter

The comparator uses capacitive coupling amplifier whose charge will be lost if the clock frequency is too low.

Therefore, make sure that  $f(\text{XIN})$  is at least on 500 kHz during an A-D conversion.

Do not execute the STP instruction during an A-D conversion.

### D-A Converter

The accuracy of the D-A converter becomes rapidly poor under the  $V_{CC} = 4.0 \text{ V}$  or less condition; a supply voltage of  $V_{CC} \geq 4.0 \text{ V}$  is recommended. When a D-A converter is not used, set all values of D-Ai conversion registers ( $i=1, 2$ ) to "0016."

### Instruction Execution Time

The instruction execution time is obtained by multiplying the period of the internal clock  $\phi$  by the number of cycles needed to execute an instruction.

The number of cycles required to execute an instruction is shown in the list of machine instructions.

The period of the internal clock  $\phi$  is double of the XIN period in high-speed mode.

## NOTES ON USAGE

### Handling of Power Source Pins

In order to avoid a latch-up occurrence, connect a capacitor suitable for high frequencies as bypass capacitor between power source pin (VCC pin) and GND pin (VSS pin), and between power source pin (VCC pin) and analog power source input pin (AVSS pin). Besides, connect the capacitor to as close as possible. For bypass capacitor which should not be located too far from the pins to be connected, a ceramic capacitor of 0.01  $\mu$ F–0.1  $\mu$ F is recommended.

### Power Source Voltage

When the power source voltage value of a microcomputer is less than the value which is indicated as the recommended operating conditions, the microcomputer does not operate normally and may perform unstable operation.

In a system where the power source voltage drops slowly when the power source voltage drops or the power supply is turned off, reset a microcomputer when the power source voltage is less than the recommended operating conditions and design a system not to cause errors to the system by this unstable operation.

### Flash Memory Version

The CNVss pin determines the flash memory mode. To improve the noise reduction, connect a track between CNVss pin and Vss pin or Vcc pin with 1 to 10 k $\Omega$  resistance. The mask ROM version track of CNVss pin has no operational interference even if it is connected to Vss pin or Vcc pin via a resistor.

### Electric Characteristic Differences Between Mask ROM and Flash Memory Version MCUs

There are differences in electric characteristics, operation margin, noise immunity, and noise radiation between Mask ROM and Flash Memory version MCUs due to the difference in the manufacturing processes, built-in ROM, and layout pattern etc. When manufacturing an application system with the Flash Memory version and then switching to use of the Mask ROM version, please conduct evaluations equivalent to the system evaluations conducted for the flash memory version.

## DATA REQUIRED FOR MASK ORDERS

The following are necessary when ordering a mask ROM production:

- 1.Mask ROM Confirmation Form \*
- 2.Mark Specification Form \*
- 3.Data to be written to ROM, in EPROM form (three identical copies)

\* For the mask ROM confirmation and the mark specifications, refer to the "Renesas Technology Corp." Homepage (<http://www.renesas.com/en/rom>).



## ELECTRICAL CHARACTERISTICS

## Absolute maximum ratings

Table 17 Absolute maximum ratings

Symbol	Parameter	Conditions	Ratings	Unit
V <sub>CC</sub>	Power source voltages	All voltages are based on V <sub>SS</sub> .	-0.3 to 6.5	V
V <sub>I</sub>	Input voltage P00-P07, P10-P17, P20-P27, P30, P31, P34-P37, P40-P47, P50-P57, P60-P67, V <sub>REF</sub>	Output transistors are cut off.	-0.3 to V <sub>CC</sub> +0.3	V
V <sub>I</sub>	Input voltage P32, P33		-0.3 to 5.8	V
V <sub>I</sub>	Input voltage RESET, X <sub>IN</sub>		-0.3 to V <sub>CC</sub> +0.3	V
V <sub>I</sub>	Input voltage CNV <sub>SS</sub>		-0.3 to V <sub>CC</sub> +0.3	V
V <sub>O</sub>	Output voltage P00-P07, P10-P17, P20-P27, P30, P31, P34-P37, P40-P47, P50-P57, P60-P67, X <sub>OUT</sub>		-0.3 to V <sub>CC</sub> +0.3	V
V <sub>O</sub>	Output voltage P32, P33		-0.3 to 5.8	V
P <sub>d</sub>	Power dissipation	T <sub>a</sub> = 25°C	1000 ( <b>Note</b> )	mW
T <sub>opr</sub>	Operating temperature		-20 to 85	°C
T <sub>stg</sub>	Storage temperature		-65 to 125	°C

**Note:** This value is 300 mW except SP package.

## Recommended operating conditions

Table 18 Recommended operating conditions (1) (Mask ROM version)

(Vcc = 1.8 to 5.5 V, Vss = 0V, Ta = -20 to 85 °C, unless otherwise noted)

Symbol	Parameter	Conditions	Limits			Unit	
			Min.	Typ.	Max.		
Vcc	Power source voltage (Note 1)	When start oscillating (Note 2)	2.2	5.0	5.5	V	
		High-speed mode $f(\phi) = f(X_{IN})/2$	$f(X_{IN}) \leq 2.1$ MHz	2.0	5.0	5.5	V
			$f(X_{IN}) \leq 4.2$ MHz	2.2	5.0	5.5	V
			$f(X_{IN}) \leq 8.4$ MHz	2.7	5.0	5.5	V
			$f(X_{IN}) \leq 12.5$ MHz	4.0	5.0	5.5	V
			$f(X_{IN}) \leq 16.8$ MHz	4.5	5.0	5.5	V
		Middle-speed mode $f(\phi) = f(X_{IN})/8$	$f(X_{IN}) \leq 6.3$ MHz	1.8	5.0	5.5	V
			$f(X_{IN}) \leq 8.4$ MHz	2.2	5.0	5.5	V
$f(X_{IN}) \leq 12.5$ MHz	2.7		5.0	5.5	V		
		$f(X_{IN}) \leq 16.8$ MHz	4.5	5.0	5.5	V	
Vss	Power source voltage			0		V	
VIH	"H" input voltage P00–P07, P10–P17, P20–P27, P30, P31, P34–P37, P40–P47, P50–P57, P60–P67	$1.8 \leq V_{cc} < 2.7$ V	0.85Vcc		Vcc	V	
		$2.7 \leq V_{cc} \leq 5.5$ V	0.8Vcc		Vcc	V	
VIH	"H" input voltage P32, P33	$1.8 \leq V_{cc} < 2.7$ V	0.85Vcc		5.5	V	
		$2.7 \leq V_{cc} \leq 5.5$ V	0.8Vcc		5.5	V	
VIH	"H" input voltage RESET, XIN, XCIN, CNVss	$1.8 \leq V_{cc} < 2.7$ V	0.85Vcc		Vcc	V	
		$2.7 \leq V_{cc} \leq 5.5$ V	0.8Vcc		Vcc	V	
VIL	"L" input voltage P00–P07, P10–P17, P20–P27, P30–P37, P40–P47, P50–P57, P60–P67	$1.8 \leq V_{cc} < 2.7$ V	0		0.16Vcc	V	
		$2.7 \leq V_{cc} \leq 5.5$ V	0		0.2Vcc	V	
VIL	"L" input voltage RESET, CNVss	$1.8 \leq V_{cc} < 2.7$ V	0		0.16Vcc	V	
		$2.7 \leq V_{cc} \leq 5.5$ V	0		0.2Vcc	V	
VIL	"L" input voltage XIN, XCIN	$1.8 \leq V_{cc} \leq 5.5$ V	0		0.16Vcc	V	

**Notes 1:** When using A-D converter, see A-D converter recommended operating conditions.**2:** The start voltage and the start time for oscillation depend on the using oscillator, oscillation circuit constant value and operating temperature range, etc.. Particularly a high-frequency oscillator might require some notes in the low voltage operation.

**Table 19 Recommended operating conditions (2) (Flash memory version)**  
(V<sub>CC</sub> = 2.7 to 5.5 V, V<sub>SS</sub> = 0V, T<sub>a</sub> = -20 to 85 °C, unless otherwise noted)

Symbol	Parameter	Conditions	Limits			Unit	
			Min.	Typ.	Max.		
V <sub>CC</sub>	Power source voltage (Note 1)	When start oscillating (Note 2)	2.7	5.0	5.5	V	
		High-speed mode $f(\phi) = f(X_{IN})/2$	$f(X_{IN}) \leq 8.4$ MHz	2.7	5.0	5.5	V
			$f(X_{IN}) \leq 12.5$ MHz	4.0	5.0	5.5	V
			$f(X_{IN}) \leq 16.8$ MHz	4.5	5.0	5.5	V
		Middle-speed mode $f(\phi) = f(X_{IN})/8$	$f(X_{IN}) \leq 12.5$ MHz	2.7	5.0	5.5	V
$f(X_{IN}) \leq 16.8$ MHz	4.5		5.0	5.5	V		
V <sub>SS</sub>	Power source voltage		0		V		
V <sub>IH</sub>	"H" input voltage P00–P07, P10–P17, P20–P27, P30, P31, P34–P37, P40–P47, P50–P57, P60–P67		0.8V <sub>CC</sub>		V <sub>CC</sub>	V	
V <sub>IH</sub>	"H" input voltage P32, P33		0.8V <sub>CC</sub>		5.5	V	
V <sub>IH</sub>	"H" input voltage RESET, X <sub>IN</sub> , CNV <sub>SS</sub>		0.8V <sub>CC</sub>		V <sub>CC</sub>	V	
V <sub>IH</sub>	"H" input voltage XC <sub>IN</sub>		2		V <sub>CC</sub>	V	
V <sub>IL</sub>	"L" input voltage P00–P07, P10–P17, P20–P27, P30–P37, P40–P47, P50–P57, P60–P67		0		0.2V <sub>CC</sub>	V	
V <sub>IL</sub>	"L" input voltage RESET, CNV <sub>SS</sub>		0		0.2V <sub>CC</sub>	V	
V <sub>IL</sub>	"L" input voltage X <sub>IN</sub>				0.16V <sub>CC</sub>	V	
V <sub>IL</sub>	"L" input voltage XC <sub>IN</sub>				0.4	V	

**Notes 1:** When using A-D converter, see A-D converter recommended operating conditions.**2:** The start voltage and the start time for oscillation depend on the using oscillator, oscillation circuit constant value and operating temperature range, etc.. Particularly a high-frequency oscillator might require some notes in the low voltage operation.

**Table 20 Recommended operating conditions (3) (Mask ROM version)****(Vcc = 1.8 to 5.5 V, Vss = 0V, Ta = -20 to 85 °C, unless otherwise noted)**

Symbol	Parameter	Conditions		Limits			Unit
				Min.	Typ.	Max.	
f(XIN)	Main clock input oscillation frequency ( <b>Note 1</b> )	High-speed mode f(φ) = f(XIN)/2	2.0 ≤ Vcc < 2.2 V			$\frac{(20 \times V_{CC} - 36) \times 1.05}{2}$	MHz
			2.2 ≤ Vcc < 2.7 V			$\frac{(24 \times V_{CC} - 40.8) \times 1.05}{3}$	MHz
			2.7 ≤ Vcc < 4.0 V			$\frac{(9 \times V_{CC} - 0.3) \times 1.05}{3}$	MHz
			4.0 ≤ Vcc < 4.5 V			$\frac{(24 \times V_{CC} - 60) \times 1.05}{3}$	MHz
			4.5 ≤ Vcc ≤ 5.5 V			16.8	MHz
		Middle-speed mode f(φ) = f(XIN)/8	1.8 ≤ Vcc < 2.2 V			$\frac{(15 \times V_{CC} - 9) \times 1.05}{3}$	MHz
			2.2 ≤ Vcc < 2.7 V			$\frac{(24 \times V_{CC} - 28.8) \times 1.05}{3}$	MHz
			2.7 ≤ Vcc < 4.5 V			$\frac{(15 \times V_{CC} + 39) \times 1.1}{7}$	MHz
4.5 ≤ Vcc ≤ 5.5 V				16.8	MHz		
f(XCIN)	Sub-clock input oscillation frequency ( <b>Notes 1, 2</b> )			32.768	50	kHz	

**Notes 1:** When the oscillation frequency has a duty cycle of 50%.**2:** When using the microcomputer in low-speed mode, set the sub-clock input oscillation frequency on condition that f(XCIN) < f(XIN)/3.

**Table 21 Recommended operating conditions (4) (Flash memory version)**  
(V<sub>CC</sub> = 2.7 to 5.5 V, V<sub>SS</sub> = 0V, T<sub>a</sub> = -20 to 85 °C, unless otherwise noted)

Symbol	Parameter	Conditions	Limits			Unit	
			Min.	Typ.	Max.		
f(X <sub>IN</sub> )	Main clock input oscillation frequency ( <b>Note 1</b> )	High-speed mode f(φ) = f(X <sub>IN</sub> )/2	2.7 ≤ V <sub>CC</sub> < 4.0 V			$\frac{(9 \times V_{CC} - 0.3) \times 1.05}{3}$	MHz
			4.0 ≤ V <sub>CC</sub> < 4.5 V			$\frac{(24 \times V_{CC} - 60) \times 1.05}{3}$	MHz
			4.5 ≤ V <sub>CC</sub> ≤ 5.5 V			16.8	MHz
		Middle-speed mode f(φ) = f(X <sub>IN</sub> )/8	2.7 ≤ V <sub>CC</sub> < 4.5 V			$\frac{(15 \times V_{CC} + 39) \times 1.1}{7}$	MHz
			4.5 ≤ V <sub>CC</sub> ≤ 5.5 V			16.8	MHz
f(X <sub>CIN</sub> )	Sub-clock input oscillation frequency ( <b>Notes 1, 2</b> )			32.768	50	kHz	

**Notes 1:** When the oscillation frequency has a duty cycle of 50%.**2:** When using the microcomputer in low-speed mode, set the sub-clock input oscillation frequency on condition that f(X<sub>CIN</sub>) < f(X<sub>IN</sub>)/3.

**Table 22 Recommended operating conditions (5)****(Mask ROM version: Vcc = 1.8 to 5.5 V, Vss = 0V, Ta = -20 to 85 °C, unless otherwise noted)****(Flash memory version: Vcc = 2.7 to 5.5 V, Vss = 0V, Ta = -20 to 85 °C, unless otherwise noted)**

Symbol	Parameter	Limits			Unit
		Min.	Typ.	Max.	
$\Sigma I_{OH(peak)}$	"H" total peak output current P00–P07, P10–P17, P20–P27, P30, P31, P34–P37 <b>(Note 1)</b>			–80	mA
$\Sigma I_{OH(peak)}$	"H" total peak output current P40–P47, P50–P57, P60–P67 <b>(Note 1)</b>			–80	mA
$\Sigma I_{OL(peak)}$	"L" total peak output current P00–P07, P10–P17, P30–P37 <b>(Note 1)</b>			80	mA
$\Sigma I_{OL(peak)}$	"L" total peak output current P20–P27 <b>(Note 1)</b>			80	mA
$\Sigma I_{OL(peak)}$	"L" total peak output current P40–P47, P50–P57, P60–P67 <b>(Note 1)</b>			80	mA
$\Sigma I_{OH(avg)}$	"H" total average output current P00–P07, P10–P17, P20–P27, P30, P31, P34–P37 <b>(Note 1)</b>			–40	mA
$\Sigma I_{OH(avg)}$	"H" total average output current P40–P47, P50–P57, P60–P67 <b>(Note 1)</b>			–40	mA
$\Sigma I_{OL(avg)}$	"L" total average output current P00–P07, P10–P17, P30–P37 <b>(Note 1)</b>			40	mA
$\Sigma I_{OL(avg)}$	"L" total average output current P20–P27 <b>(Note 1)</b>			40	mA
$\Sigma I_{OL(avg)}$	"L" total average output current P40–P47, P50–P57, P60–P67 <b>(Note 1)</b>			40	mA
$I_{OH(peak)}$	"H" peak output current P00–P07, P10–P17, P20–P27, P30, P31, P34–P37, P40–P47, P50–P57, P60–P67 <b>(Note 2)</b>			–10	mA
$I_{OL(peak)}$	"L" peak output current P00–P07, P10–P17, P30–P37, P40–P47, P50–P57, P60–P67 <b>(Note 2)</b>			10	mA
$I_{OL(peak)}$	"L" peak output current P20–P27 <b>(Note 2)</b>			20	mA
$I_{OH(avg)}$	"H" average output current P00–P07, P10–P17, P20–P27, P30, P31, P34–P37, P40–P47, P50–P57, P60–P67 <b>(Note 3)</b>			–5	mA
$I_{OL(avg)}$	"L" average output current P00–P07, P10–P17, P30–P37, P40–P47, P50–P57, P60–P67 <b>(Note 3)</b>			5	mA
$I_{OL(avg)}$	"L" average output current P20–P27 <b>(Note 3)</b>			10	mA

**Notes 1:** The total output current is the sum of all the currents flowing through all the applicable ports. The total average current is an average value measured over 100 ms. The total peak current is the peak value of all the currents.

**2:** The peak output current is the peak current flowing in each port.

**3:** The average output current  $I_{OL(avg)}$ ,  $I_{OH(avg)}$  are average value measured over 100 ms.

## Electrical characteristics

Table 23 Electrical characteristics (1)

(Mask ROM version:  $V_{CC} = 1.8$  to  $5.5$  V,  $V_{SS} = 0$  V,  $T_a = -20$  to  $85$  °C, unless otherwise noted)(Flash memory version:  $V_{CC} = 2.7$  to  $5.5$  V,  $V_{SS} = 0$  V,  $T_a = -20$  to  $85$  °C, unless otherwise noted)

Symbol	Parameter	Test conditions	Limits			Unit
			Min.	Typ.	Max.	
VOH	“H” output voltage P00–P07, P10–P17, P20–P27, P30, P31, P34–P37, P40–P47, P50–P57, P60–P67 (Note 1)	$I_{OH} = -10$ mA $V_{CC} = 4.0$ to $5.5$ V	$V_{CC} - 2.0$			V
		$I_{OH} = -1.0$ mA $V_{CC} = 1.8$ to $5.5$ V	$V_{CC} - 1.0$			V
VOL	“L” output voltage P00–P07, P10–P17, P20–P27, P30–P37, P40–P47, P50–P57, P60–P67	$I_{OL} = 10$ mA $V_{CC} = 4.0$ to $5.5$ V			2.0	V
		$I_{OL} = 1.6$ mA $V_{CC} = 1.8$ to $5.5$ V			1.0	V
VOL	“L” output voltage P20–P27	$I_{OL} = 20$ mA $V_{CC} = 4.0$ to $5.5$ V			2.0	V
		$I_{OL} = 1.6$ mA $V_{CC} = 1.8$ to $5.5$ V			0.4	V
VT+–VT–	Hysteresis CNTR0, CNTR1, CNTR2, INT0–INT4		0.4			V
VT+–VT–	Hysteresis RxD1, SCLK1, SIN2, SCLK2, RxD3, SCLK3		0.5			V
VT+–VT–	Hysteresis RESET		0.5			V
I <sub>IH</sub>	“H” input current P00–P07, P10–P17, P20–P27, P30–P37, P40–P47, P50–P57, P60–P67	$V_i = V_{CC}$ (Pin floating. Pull-up transistors “off”)			5.0	μA
I <sub>IH</sub>	“H” input current RESET, CNV <sub>SS</sub>	$V_i = V_{CC}$			5.0	μA
I <sub>IH</sub>	“H” input current X <sub>IN</sub>	$V_i = V_{CC}$	4.0			μA
I <sub>IL</sub>	“L” input current P00–P07, P10–P17, P20–P27, P30–P37, P40–P47, P50–P57, P60–P67	$V_i = V_{SS}$ (Pin floating. Pull-up transistors “off”)			–5.0	μA
I <sub>IL</sub>	“L” input current RESET, CNV <sub>SS</sub>	$V_i = V_{SS}$			–5.0	μA
I <sub>IL</sub>	“L” input current X <sub>IN</sub>	$V_i = V_{SS}$	–4.0			μA
I <sub>IL</sub>	“L” input current (at Pull-up) P00–P07, P10–P17, P20–P27, P30, P31, P34–P37, P40–P47, P50–P57, P60–P67	$V_i = V_{SS}$ $V_{CC} = 5.0$ V	–80	–210	–420	μA
		$V_i = V_{SS}$ $V_{CC} = 3.0$ V	–30	–70	–140	μA
VRAM	RAM hold voltage	When clock stopped	1.8		$V_{CC}$	V

**Note 1:** P35 is measured when the P35/TxD3 P-channel output disable bit of the UART3 control register (bit 4 of address 003316) is “0”.  
P45 is measured when the P45/TxD1 P-channel output disable bit of the UART1 control register (bit 4 of address 001B16) is “0”.

**Table 24 Electrical characteristics (2) (Mask ROM version)****(V<sub>CC</sub> = 1.8 to 5.5 V, T<sub>a</sub> = -20 to 85 °C, f(X<sub>CIN</sub>)=32.768kHz (Stopped in middle-speed mode), Output transistors “off”, AD converter not operated)**

Symbol	Parameter	Test conditions			Limits			Unit		
					Min.	Typ.	Max.			
I <sub>CC</sub>	Power source current	High-speed mode	V <sub>CC</sub> = 5V	f(X <sub>IN</sub> ) = 16.8 MHz		8.0	15.0	mA		
				f(X <sub>IN</sub> ) = 12.5 MHz		6.5	12.0	mA		
				f(X <sub>IN</sub> ) = 8.4 MHz		5.0	9.0	mA		
				f(X <sub>IN</sub> ) = 4.2 MHz		2.5	5.0	mA		
				f(X <sub>IN</sub> ) = 16.8 MHz (in WIT state)		2.0	3.6	mA		
			V <sub>CC</sub> = 3V	f(X <sub>IN</sub> ) = 8.4 MHz		1.9	3.8	mA		
				f(X <sub>IN</sub> ) = 4.2 MHz		1.0	2.0	mA		
				f(X <sub>IN</sub> ) = 2.1 MHz		0.6	1.2	mA		
				Middle-speed mode	V <sub>CC</sub> = 5V	f(X <sub>IN</sub> ) = 16.8 MHz		4.0	7.0	mA
						f(X <sub>IN</sub> ) = 12.5 MHz		3.0	6.0	mA
		V <sub>CC</sub> = 3V	f(X <sub>IN</sub> ) = 8.4 MHz			2.5	5.0	mA		
			f(X <sub>IN</sub> ) = 16.8 MHz (in WIT state)			1.8	3.3	mA		
		Low-speed mode	V <sub>CC</sub> = 5V	f(X <sub>IN</sub> ) = 12.5 MHz		1.5	3.0	mA		
				f(X <sub>IN</sub> ) = 8.4 MHz		1.2	2.4	mA		
				f(X <sub>IN</sub> ) = 6.3 MHz		1.0	2.0	mA		
				f(X <sub>IN</sub> ) = stopped		55	200	μA		
			V <sub>CC</sub> = 3V	In WIT state		40	70	μA		
				f(X <sub>IN</sub> ) = stopped		15	40	μA		
			V <sub>CC</sub> = 2V	In WIT state		8	15	μA		
				f(X <sub>IN</sub> ) = stopped		6	15	μA		
		In STP state (All oscillation stopped)		T <sub>a</sub> = 25 °C		0.1	1.0	μA		
T <sub>a</sub> = 85 °C					10	μA				
Increment when A-D conversion is executed		f(X <sub>IN</sub> ) = 16.8 MHz, V <sub>CC</sub> = 5V In Middle-, high-speed mode		500		μA				



**Table 25 Electrical characteristics (3) (Flash memory version)****(V<sub>CC</sub> = 2.7 to 5.5 V, T<sub>a</sub> = -20 to 85 °C, f(X<sub>CIN</sub>)=32.768kHz (Stoped in middle-speed mode), Output transistors "off", AD converter not operated)**

Symbol	Parameter	Test conditions			Limits			Unit		
					Min.	Typ.	Max.			
I <sub>CC</sub>	Power source current	High-speed mode	V <sub>CC</sub> = 5V	f(X <sub>IN</sub> ) = 16.8 MHz		5.5	8.3	mA		
				f(X <sub>IN</sub> ) = 12.5 MHz		4.5	6.8	mA		
				f(X <sub>IN</sub> ) = 8.4 MHz		3.5	5.3	mA		
				f(X <sub>IN</sub> ) = 4.2 MHz		2.2	3.3	mA		
				f(X <sub>IN</sub> ) = 16.8 MHz (in WIT state)		2.2	3.3	mA		
			V <sub>CC</sub> = 3V	f(X <sub>IN</sub> ) = 8.4 MHz		2.7	4.1	mA		
				f(X <sub>IN</sub> ) = 4.2 MHz		1.8	2.7	mA		
				f(X <sub>IN</sub> ) = 2.1 MHz		1.1	1.7	mA		
				Middle-speed mode	V <sub>CC</sub> = 5V	f(X <sub>IN</sub> ) = 16.8 MHz		3.0	4.5	mA
						f(X <sub>IN</sub> ) = 12.5 MHz		2.4	3.6	mA
		V <sub>CC</sub> = 3V	f(X <sub>IN</sub> ) = 8.4 MHz			2.0	3.0	mA		
			f(X <sub>IN</sub> ) = 16.8 MHz (in WIT state)			2.1	3.2	mA		
		Low-speed mode	V <sub>CC</sub> = 5V	f(X <sub>IN</sub> ) = stopped		410	630	μA		
				In WIT state		4.5	6.8	μA		
				V <sub>CC</sub> = 3V	f(X <sub>IN</sub> ) = stopped		400	600	μA	
			In WIT state			3.7	5.6	μA		
			In STP state (All oscillation stopped)		T <sub>a</sub> = 25 °C		0.55	3.0	μA	
				T <sub>a</sub> = 85 °C		0.75		μA		
		Increment when A-D conversion is executed	f(X <sub>IN</sub> ) = 16.8 MHz, V <sub>CC</sub> = 5V In Middle-, high-speed mode		1000		μA			

**A-D converter characteristics****Table 26 A-D converter recommended operating conditions (Mask ROM version)**(V<sub>CC</sub> = 2.0 to 5.5 V, V<sub>SS</sub> = AV<sub>SS</sub> = 0 V, T<sub>a</sub> = -20 to 85 °C, unless otherwise noted)

Symbol	Parameter	Conditions	Limits			Unit
			Min.	Typ.	Max.	
V <sub>CC</sub>	Power source voltage (When A-D converter is used)	8-bit A-D mode ( <b>Note 1</b> )	2.0	5.0	5.5	V
		10-bit A-D mode ( <b>Note 2</b> )	2.2	5.0	5.5	
V <sub>REF</sub>	Analog reference voltage		2.0		V <sub>CC</sub>	V
AV <sub>SS</sub>	Analog power source voltage			0		V
V <sub>IA</sub>	Analog input voltage		0		V <sub>CC</sub>	V
f(XIN)	Main clock oscillation frequency (When A-D converter is used)	2.0 ≤ V <sub>CC</sub> < 2.2 V	0.5		$\frac{(20 \times V_{CC} - 36) \times 1.05}{2}$	MHz
		2.2 ≤ V <sub>CC</sub> < 2.7 V	0.5		$\frac{(24 \times V_{CC} - 40.8) \times 1.05}{3}$	
		2.7 ≤ V <sub>CC</sub> < 4.0 V	0.5		$\frac{(9 \times V_{CC} - 0.3) \times 1.05}{3}$	
		4.0 ≤ V <sub>CC</sub> < 4.5 V	0.5		$\frac{(24 \times V_{CC} - 60) \times 1.05}{3}$	
		4.5 ≤ V <sub>CC</sub> ≤ 5.5 V	0.5		16.8	

**Notes 1:** 8-bit A-D mode: When the conversion mode selection bit (bit 7 of address 003816) is "1".**2:** 10-bit A-D mode: When the conversion mode selection bit (bit 7 of address 003816) is "0".**Table 27 A-D converter characteristics (Mask ROM version)**(V<sub>CC</sub> = 2.0 to 5.5 V, V<sub>SS</sub> = AV<sub>SS</sub> = 0 V, T<sub>a</sub> = -20 to 85 °C, unless otherwise noted)

Symbol	Parameter	Test conditions	Limits			Unit	
			Min.	Typ.	Max.		
-	Resolution	8-bit A-D mode ( <b>Note 1</b> )			8	bit	
		10-bit A-D mode ( <b>Note 2</b> )			10		
-	Absolute accuracy (excluding quantization error)	8-bit A-D mode ( <b>Note 1</b> )	2.0 ≤ V <sub>REF</sub> < 2.2 V		±3	LSB	
			2.2 ≤ V <sub>REF</sub> ≤ 5.5 V		±2		
		10-bit A-D mode ( <b>Note 2</b> )	2.2 ≤ V <sub>REF</sub> < 2.7 V		±5		
			2.7 ≤ V <sub>REF</sub> ≤ 5.5 V		±4		
t <sub>CONV</sub>	Conversion time	8-bit A-D mode ( <b>Note 1</b> )			50	2t <sub>c</sub> (XIN)	
		10-bit A-D mode ( <b>Note 2</b> )			61		
RLADDER	Ladder resistor		12	35	100	kΩ	
I <sub>VREF</sub>	Reference power source input current	at A-D converter operated	V <sub>REF</sub> = 5.0 V	50	150	200	μA
		at A-D converter stopped	V <sub>REF</sub> = 5.0 V			5	μA
I <sub>I(AD)</sub>	A-D port inout current				5	μA	

**Notes 1:** 8-bit A-D mode: When the conversion mode selection bit (bit 7 of address 003816) is "1".**2:** 10-bit A-D mode: When the conversion mode selection bit (bit 7 of address 003816) is "0".**D-A converter characteristics****Table 28 D-A converter characteristics (Mask ROM version)**(V<sub>CC</sub> = 2.7 to 5.5 V, V<sub>REF</sub> = 2.7 V to V<sub>CC</sub>, V<sub>SS</sub> = AV<sub>SS</sub> = 0 V, T<sub>a</sub> = -20 to 85 °C, unless otherwise noted)

Symbol	Parameter	Test conditions	Limits			Unit
			Min.	Typ.	Max.	
-	Resolution				8	bit
-	Absolute accuracy	4.0 ≤ V <sub>REF</sub> ≤ 5.5 V			1.0	%
		2.7 ≤ V <sub>REF</sub> < 4.0 V			2.5	%
t <sub>su</sub>	Setting time				3	μs
RO	Output resistor		2	3.5	5	kΩ
I <sub>VREF</sub>	Reference power source input current ( <b>Note 1</b> )				3.2	mA

**Note 1:** Using one D-A converter, with the value in the D-A conversion register of the other D-A converter being "0016".

## 3803 Group (Spec. H) Flash Memory Version

**Table 29 A-D converter recommended operating conditions (Flash memory version)**(V<sub>CC</sub> = 2.7 to 5.5 V, V<sub>SS</sub> = AV<sub>SS</sub> = 0 V, T<sub>a</sub> = -20 to 85 °C, unless otherwise noted)

Symbol	Parameter	Conditions	Limits			Unit
			Min.	Typ.	Max.	
V <sub>CC</sub>	Power source voltage (When A-D converter is used)	8-bit A-D mode ( <b>Note 1</b> )	2.7	5.0	5.5	V
		10-bit A-D mode ( <b>Note 2</b> )	2.7	5.0	5.5	
V <sub>REF</sub>	Analog reference voltage		2.0		V <sub>CC</sub>	V
AV <sub>SS</sub>	Analog power source voltage			0		V
V <sub>IA</sub>	Analog input voltage		0		V <sub>CC</sub>	V
f(XIN)	Main clock oscillation frequency (When A-D converter is used)	2.7 ≤ V <sub>CC</sub> < 4.0 V	0.5		$\frac{(9 \times V_{CC} - 0.3) \times 1.05}{3}$	MHz
		4.0 ≤ V <sub>CC</sub> < 4.5 V	0.5		$\frac{(24 \times V_{CC} - 60) \times 1.05}{3}$	
		4.5 ≤ V <sub>CC</sub> ≤ 5.5 V	0.5		16.8	

**Note 1:** 8-bit A-D mode: When the conversion mode selection bit (bit 7 of address 003816) is "1".**Note 2:** 10-bit A-D mode: When the conversion mode selection bit (bit 7 of address 003816) is "0".**Table 30 A-D converter characteristics (Flash memory version)**(V<sub>CC</sub> = 2.7 to 5.5 V, V<sub>SS</sub> = AV<sub>SS</sub> = 0 V, T<sub>a</sub> = -20 to 85 °C, unless otherwise noted)

Symbol	Parameter		Test conditions	Limits			Unit
				Min.	Typ.	Max.	
-	Resolution		8-bit A-D mode ( <b>Note 1</b> )			8	bit
			10-bit A-D mode ( <b>Note 2</b> )			10	
-	Absolute accuracy (excluding quantization error)		8-bit A-D mode ( <b>Note 1</b> ) 2.7 ≤ V <sub>REF</sub> ≤ 5.5 V			±2	LSB
			10-bit A-D mode ( <b>Note 2</b> ) 2.7 ≤ V <sub>REF</sub> ≤ 5.5 V			±4	
t <sub>CONV</sub>	Conversion time		8-bit A-D mode ( <b>Note 1</b> )			50	2t <sub>c</sub> (XIN)
			10-bit A-D mode ( <b>Note 2</b> )			61	
RLADDER	Ladder resistor			12	35	100	kΩ
I <sub>VREF</sub>	Reference power source input current	at A-D converter operated	V <sub>REF</sub> = 5.0 V	50	150	200	μA
		at A-D converter stopped	V <sub>REF</sub> = 5.0 V			5	μA
I <sub>I(AD)</sub>	A-D port in/out current					5	μA

**Note 1:** 8-bit A-D mode: When the conversion mode selection bit (bit 7 of address 003816) is "1".**Note 2:** 10-bit A-D mode: When the conversion mode selection bit (bit 7 of address 003816) is "0".**D-A converter characteristics****Table 31 D-A converter characteristics (Flash memory version)**(V<sub>CC</sub> = 2.7 to 5.5 V, V<sub>REF</sub> = 2.7 V to V<sub>CC</sub>, V<sub>SS</sub> = AV<sub>SS</sub> = 0 V, T<sub>a</sub> = -20 to 85 °C, unless otherwise noted)

Symbol	Parameter		Test conditions	Limits			Unit
				Min.	Typ.	Max.	
-	Resolution					8	bit
-	Absolute accuracy	4.0 ≤ V <sub>REF</sub> ≤ 5.5 V				1.0	%
		2.7 ≤ V <sub>REF</sub> < 4.0 V				2.5	%
t <sub>su</sub>	Setting time					3	μs
RO	Output resistor			2	3.5	5	kΩ
I <sub>VREF</sub>	Reference power source input current ( <b>Note 1</b> )					3.2	mA

**Note 1:** Using one D-A converter, with the value in the D-A conversion register of the other D-A converter being "0016".**Power source circuit timing characteristics****Table 32 Power source circuit timing characteristics (Flash memory version)**(V<sub>CC</sub> = 2.7 to 5.5 V, V<sub>REF</sub> = 2.7 V to V<sub>CC</sub>, V<sub>SS</sub> = AV<sub>SS</sub> = 0 V, T<sub>a</sub> = -20 to 85 °C, unless otherwise noted)

Symbol	Parameter	Test conditions	Limits			Unit
			Min.	Typ.	Max.	
td(P-R)	Internal power source stable time at power-on	2.7 ≤ V <sub>CC</sub> < 5.5 V			2	ms

## Timing requirements and switching characteristics

Table 33 Timing requirements (1)

(Mask ROM version:  $V_{CC} = 2.0$  to  $5.5$  V,  $V_{SS} = 0$  V,  $T_a = -20$  to  $85$  °C, unless otherwise noted)(Flash memory version:  $V_{CC} = 2.7$  to  $5.5$  V,  $V_{SS} = 0$  V,  $T_a = -20$  to  $85$  °C, unless otherwise noted)

Symbol	Parameter		Limits			Unit
			Min.	Typ.	Max.	
tw(RESET)	Reset input "L" pulse width (Mask ROM version)		16			XIN cycle
	Reset input "L" pulse width (Flash memory version)		td(P-R) ms + 16			
tc(XIN)	Main clock XIN input cycle time	$4.5 \leq V_{CC} \leq 5.5$ V	59.5			ns
		$4.0 \leq V_{CC} < 4.5$ V	$10000 / (86V_{CC} - 219)$			
		$2.7 \leq V_{CC} < 4.0$ V	$26 \times 10^3 / (82V_{CC} - 3)$			
		$2.2 \leq V_{CC} < 2.7$ V	$10000 / (84V_{CC} - 143)$			
		$2.0 \leq V_{CC} < 2.2$ V	$10000 / (105V_{CC} - 189)$			
twh(XIN)	Main clock XIN input "H" pulse width	$4.5 \leq V_{CC} \leq 5.5$ V	25			ns
		$4.0 \leq V_{CC} < 4.5$ V	$4000 / (86V_{CC} - 219)$			
		$2.7 \leq V_{CC} < 4.0$ V	$10000 / (82V_{CC} - 3)$			
		$2.2 \leq V_{CC} < 2.7$ V	$4000 / (84V_{CC} - 143)$			
		$2.0 \leq V_{CC} < 2.2$ V	$4000 / (105V_{CC} - 189)$			
twl(XIN)	Main clock XIN input "L" pulse width	$4.5 \leq V_{CC} \leq 5.5$ V	25			ns
		$4.0 \leq V_{CC} < 4.5$ V	$4000 / (86V_{CC} - 219)$			
		$2.7 \leq V_{CC} < 4.0$ V	$10000 / (82V_{CC} - 3)$			
		$2.2 \leq V_{CC} < 2.7$ V	$4000 / (84V_{CC} - 143)$			
		$2.0 \leq V_{CC} < 2.2$ V	$4000 / (105V_{CC} - 189)$			
tc(XCIN)	Sub-clock XCIN input cycle time		20			$\mu$ s
twh(XCIN)	Sub-clock XCIN input "H" pulse width		5			$\mu$ s
twl(XCIN)	Sub-clock XCIN input "L" pulse width		5			$\mu$ s
tc(CNTR)	CNTR0–CNTR2 input cycle time	$4.5 \leq V_{CC} \leq 5.5$ V	120			ns
		$4.0 \leq V_{CC} < 4.5$ V	160			
		$2.7 \leq V_{CC} < 4.0$ V	250			
		$2.2 \leq V_{CC} < 2.7$ V	500			
		$2.0 \leq V_{CC} < 2.2$ V	1000			
twh(CNTR)	CNTR0–CNTR2 input "H" pulse width	$4.5 \leq V_{CC} \leq 5.5$ V	48			ns
		$4.0 \leq V_{CC} < 4.5$ V	64			
		$2.7 \leq V_{CC} < 4.0$ V	115			
		$2.2 \leq V_{CC} < 2.7$ V	230			
		$2.0 \leq V_{CC} < 2.2$ V	460			
twl(CNTR)	CNTR0–CNTR2 input "L" pulse width	$4.5 \leq V_{CC} \leq 5.5$ V	48			ns
		$4.0 \leq V_{CC} < 4.5$ V	64			
		$2.7 \leq V_{CC} < 4.0$ V	115			
		$2.2 \leq V_{CC} < 2.7$ V	230			
		$2.0 \leq V_{CC} < 2.2$ V	460			
twh(INT)	INT00, INT01, INT1, INT2, INT3, INT40, INT41 input "H" pulse width	$4.5 \leq V_{CC} \leq 5.5$ V	48			ns
		$4.0 \leq V_{CC} < 4.5$ V	64			
		$2.7 \leq V_{CC} < 4.0$ V	115			
		$2.2 \leq V_{CC} < 2.7$ V	230			
		$2.0 \leq V_{CC} < 2.2$ V	460			
twl(INT)	INT00, INT01, INT1, INT2, INT3, INT40, INT41 input "L" pulse width	$4.5 \leq V_{CC} \leq 5.5$ V	48			ns
		$4.0 \leq V_{CC} < 4.5$ V	64			
		$2.7 \leq V_{CC} < 4.0$ V	115			
		$2.2 \leq V_{CC} < 2.7$ V	230			
		$2.0 \leq V_{CC} < 2.2$ V	460			

**Table 34 Timing requirements (2)****(Mask ROM version: Vcc = 2.0 to 5.5 V, Vss = 0V, Ta = -20 to 85 °C, unless otherwise noted)****(Flash memory version: Vcc = 2.7 to 5.5 V, Vss = 0V, Ta = -20 to 85 °C, unless otherwise noted)**

Symbol	Parameter	Limits			Unit
		Min.	Typ.	Max.	
tc(SCLK1), tc(SCLK3)	Serial I/O1, serial I/O3 clock input cycle time <b>(Note)</b>	4.5≤Vcc≤5.5 V	250		ns
		4.0≤Vcc<4.5 V	320		
		2.7≤Vcc<4.0 V	500		
		2.2≤Vcc<2.7 V	1000		
		2.0≤Vcc<2.2 V	2000		
twh(SCLK1), twh(SCLK3)	Serial I/O1, serial I/O3 clock input "H" pulse width <b>(Note)</b>	4.5≤Vcc≤5.5 V	120		ns
		4.0≤Vcc<4.5 V	150		
		2.7≤Vcc<4.0 V	240		
		2.2≤Vcc<2.7 V	480		
		2.0≤Vcc<2.2 V	950		
twl(SCLK1), twl(SCLK3)	Serial I/O1, serial I/O3 clock input "L" pulse width <b>(Note)</b>	4.5≤Vcc≤5.5 V	120		ns
		4.0≤Vcc<4.5 V	150		
		2.7≤Vcc<4.0 V	240		
		2.2≤Vcc<2.7 V	480		
		2.0≤Vcc<2.2 V	950		
tsu(RxD1-SCLK1), tsu(RxD3-SCLK3)	Serial I/O1, serial I/O3 clock input setup time	4.5≤Vcc≤5.5 V	70		ns
		4.0≤Vcc<4.5 V	90		
		2.7≤Vcc<4.0 V	100		
		2.2≤Vcc<2.7 V	200		
		2.0≤Vcc<2.2 V	400		
th(SCLK1-RxD1), th(SCLK3-RxD3)	Serial I/O1, serial I/O3 clock input hold time	4.5≤Vcc≤5.5 V	32		ns
		4.0≤Vcc<4.5 V	40		
		2.7≤Vcc<4.0 V	50		
		2.2≤Vcc<2.7 V	100		
		2.0≤Vcc<2.2 V	200		
tc(SCLK2)	Serial I/O2 clock input cycle time	4.5≤Vcc≤5.5 V	500		ns
		4.0≤Vcc<4.5 V	650		
		2.7≤Vcc<4.0 V	1000		
		2.2≤Vcc<2.7 V	2000		
		2.0≤Vcc<2.2 V	4000		
twh(SCLK2)	Serial I/O2 clock input "H" pulse width	4.5≤Vcc≤5.5 V	200		ns
		4.0≤Vcc<4.5 V	260		
		2.7≤Vcc<4.0 V	400		
		2.2≤Vcc<2.7 V	950		
		2.0≤Vcc<2.2 V	2000		
twl(SCLK2)	Serial I/O2 clock input "L" pulse width	4.5≤Vcc≤5.5 V	200		ns
		4.0≤Vcc<4.5 V	260		
		2.7≤Vcc<4.0 V	400		
		2.2≤Vcc<2.7 V	950		
		2.0≤Vcc<2.2 V	2000		
tsu(SIN2-SCLK2)	Serial I/O2 clock input setup time	4.5≤Vcc≤5.5 V	100		ns
		4.0≤Vcc<4.5 V	130		
		2.7≤Vcc<4.0 V	200		
		2.2≤Vcc<2.7 V	400		
		2.0≤Vcc<2.2 V	800		
th(SCLK2-SIN2)	Serial I/O2 clock input hold time	4.5≤Vcc≤5.5 V	100		ns
		4.0≤Vcc<4.5 V	130		
		2.7≤Vcc<4.0 V	150		
		2.2≤Vcc<2.7 V	300		
		2.0≤Vcc<2.2 V	600		

**Note :** When bit 6 of address 001A16 and bit 6 of address 003216 are "1" (clock synchronous).

Divide this value by four when bit 6 of address 001A16 and bit 6 of address 003216 are "0" (UART).

Table 35 Switching characteristics (1)

(Mask ROM version:  $V_{CC} = 2.0$  to  $5.5$  V,  $V_{SS} = 0$  V,  $T_a = -20$  to  $85$  °C, unless otherwise noted)(Flash memory version:  $V_{CC} = 2.7$  to  $5.5$  V,  $V_{SS} = 0$  V,  $T_a = -20$  to  $85$  °C, unless otherwise noted)

Symbol	Parameter	Test conditions	Limits			Unit	
			Min.	Typ.	Max.		
t <sub>WH</sub> (SCLK1) t <sub>WH</sub> (SCLK3)	Serial I/O1, serial I/O3 clock output "H" pulse width	4.5 ≤ V <sub>CC</sub> ≤ 5.5 V 4.0 ≤ V <sub>CC</sub> < 4.5 V 2.7 ≤ V <sub>CC</sub> < 4.0 V 2.2 ≤ V <sub>CC</sub> < 2.7 V 2.0 ≤ V <sub>CC</sub> < 2.2 V	Fig. 80	tC(SCLK1)2-30, tC(SCLK3)2-30			ns
				tC(SCLK1)2-35, tC(SCLK3)2-35			
				tC(SCLK1)2-40, tC(SCLK3)2-40			
				tC(SCLK1)2-45, tC(SCLK3)2-45			
				tC(SCLK1)2-50, tC(SCLK3)2-50			
t <sub>WL</sub> (SCLK1) t <sub>WL</sub> (SCLK3)	Serial I/O1, serial I/O3 clock output "L" pulse width	4.5 ≤ V <sub>CC</sub> ≤ 5.5 V 4.0 ≤ V <sub>CC</sub> < 4.5 V 2.7 ≤ V <sub>CC</sub> < 4.0 V 2.2 ≤ V <sub>CC</sub> < 2.7 V 2.0 ≤ V <sub>CC</sub> < 2.2 V	Fig. 80	tC(SCLK1)2-30, tC(SCLK3)2-30			ns
				tC(SCLK1)2-35, tC(SCLK3)2-35			
				tC(SCLK1)2-40, tC(SCLK3)2-40			
				tC(SCLK1)2-45, tC(SCLK3)2-45			
				tC(SCLK1)2-50, tC(SCLK3)2-50			
t <sub>d</sub> (SCLK1-TxD1) t <sub>d</sub> (SCLK3-TxD3)	Serial I/O1, serial I/O3 output delay time (Note)	4.5 ≤ V <sub>CC</sub> ≤ 5.5 V 4.0 ≤ V <sub>CC</sub> < 4.5 V 2.7 ≤ V <sub>CC</sub> < 4.0 V 2.2 ≤ V <sub>CC</sub> < 2.7 V 2.0 ≤ V <sub>CC</sub> < 2.2 V	Fig. 80			140	ns
						200	
						350	
						400	
						420	
t <sub>v</sub> (SCLK1-TxD1) t <sub>v</sub> (SCLK3-TxD3)	Serial I/O1, serial I/O3 output valid time (Note)	4.5 ≤ V <sub>CC</sub> ≤ 5.5 V 4.0 ≤ V <sub>CC</sub> < 4.5 V 2.7 ≤ V <sub>CC</sub> < 4.0 V 2.2 ≤ V <sub>CC</sub> < 2.7 V 2.0 ≤ V <sub>CC</sub> < 2.2 V	Fig. 80	-30			ns
				-30			
				-30			
				-30			
				-30			
t <sub>r</sub> (SCLK1) t <sub>r</sub> (SCLK3)	Serial I/O1, serial I/O3 rise time of clock output	4.5 ≤ V <sub>CC</sub> ≤ 5.5 V 4.0 ≤ V <sub>CC</sub> < 4.5 V 2.7 ≤ V <sub>CC</sub> < 4.0 V 2.2 ≤ V <sub>CC</sub> < 2.7 V 2.0 ≤ V <sub>CC</sub> < 2.2 V	Fig. 80			30	ns
						35	
						40	
						45	
						50	
t <sub>f</sub> (SCLK1) t <sub>f</sub> (SCLK3)	Serial I/O1, serial I/O3 fall time of clock output	4.5 ≤ V <sub>CC</sub> ≤ 5.5 V 4.0 ≤ V <sub>CC</sub> < 4.5 V 2.7 ≤ V <sub>CC</sub> < 4.0 V 2.2 ≤ V <sub>CC</sub> < 2.7 V 2.0 ≤ V <sub>CC</sub> < 2.2 V	Fig. 80			30	ns
						35	
						40	
						45	
						50	
t <sub>WH</sub> (SCLK2)	Serial I/O2 clock output "H" pulse width	4.5 ≤ V <sub>CC</sub> ≤ 5.5 V 4.0 ≤ V <sub>CC</sub> < 4.5 V 2.7 ≤ V <sub>CC</sub> < 4.0 V 2.2 ≤ V <sub>CC</sub> < 2.7 V 2.0 ≤ V <sub>CC</sub> < 2.2 V	Fig. 80	tC(SCLK2)2-160			ns
				tC(SCLK2)2-200			
				tC(SCLK2)2-240			
				tC(SCLK2)2-260			
				tC(SCLK2)2-280			
t <sub>WL</sub> (SCLK2)	Serial I/O2 clock output "L" pulse width	4.5 ≤ V <sub>CC</sub> ≤ 5.5 V 4.0 ≤ V <sub>CC</sub> < 4.5 V 2.7 ≤ V <sub>CC</sub> < 4.0 V 2.2 ≤ V <sub>CC</sub> < 2.7 V 2.0 ≤ V <sub>CC</sub> < 2.2 V	Fig. 80	tC(SCLK2)2-160			ns
				tC(SCLK2)2-200			
				tC(SCLK2)2-240			
				tC(SCLK2)2-260			
				tC(SCLK2)2-280			
t <sub>d</sub> (SCLK2-SOUT2)	Serial I/O2 output delay time	4.5 ≤ V <sub>CC</sub> ≤ 5.5 V 4.0 ≤ V <sub>CC</sub> < 4.5 V 2.7 ≤ V <sub>CC</sub> < 4.0 V 2.2 ≤ V <sub>CC</sub> < 2.7 V 2.0 ≤ V <sub>CC</sub> < 2.2 V	Fig. 80			200	ns
						250	
						300	
						350	
						400	
t <sub>v</sub> (SCLK2-SOUT2)	Serial I/O2 output valid time	4.5 ≤ V <sub>CC</sub> ≤ 5.5 V 4.0 ≤ V <sub>CC</sub> < 4.5 V 2.7 ≤ V <sub>CC</sub> < 4.0 V 2.2 ≤ V <sub>CC</sub> < 2.7 V 2.0 ≤ V <sub>CC</sub> < 2.2 V	Fig. 80		0		ns
					0		
					0		
					0		
					0		

Note: When the P45/TxD1 P-channel output disable bit of the UART1 control register (bit 4 of address 001B16) is "0".

**Table 36 Switching characteristics (2)****(Mask ROM version: V<sub>CC</sub> = 2.0 to 5.5 V, V<sub>SS</sub> = 0V, T<sub>a</sub> = -20 to 85 °C, unless otherwise noted)****(Flash memory version: V<sub>CC</sub> = 2.7 to 5.5 V, V<sub>SS</sub> = 0V, T<sub>a</sub> = -20 to 85 °C, unless otherwise noted)**

Symbol	Parameter	Test conditions	Limits			Unit
			Min.	Typ.	Max.	
tr(SCLK2)	Serial I/O2 fall time of clock output	Fig. 80	4.5 ≤ V <sub>CC</sub> ≤ 5.5 V		30	ns
			4.0 ≤ V <sub>CC</sub> < 4.5 V		35	
			2.7 ≤ V <sub>CC</sub> < 4.0 V		40	
			2.2 ≤ V <sub>CC</sub> < 2.7 V		45	
			2.0 ≤ V <sub>CC</sub> < 2.2 V		50	
tr(CMOS)	CMOS rise time of output <b>(Note)</b>	Fig. 80	4.5 ≤ V <sub>CC</sub> ≤ 5.5 V	10	30	ns
			4.0 ≤ V <sub>CC</sub> < 4.5 V	12	35	
			2.7 ≤ V <sub>CC</sub> < 4.0 V	15	40	
			2.2 ≤ V <sub>CC</sub> < 2.7 V	17	45	
			2.0 ≤ V <sub>CC</sub> < 2.2 V	20	50	
tr(CMOS)	CMOS fall time of output <b>(Note)</b>	Fig. 80	4.5 ≤ V <sub>CC</sub> ≤ 5.5 V	10	30	ns
			4.0 ≤ V <sub>CC</sub> < 4.5 V	12	35	
			2.7 ≤ V <sub>CC</sub> < 4.0 V	15	40	
			2.2 ≤ V <sub>CC</sub> < 2.7 V	17	45	
			2.0 ≤ V <sub>CC</sub> < 2.2 V	20	50	

**Note:** When the P35/TxD3 P4-channel output disable bit of the UART3 control register (bit 4 of address 003316) is "0".

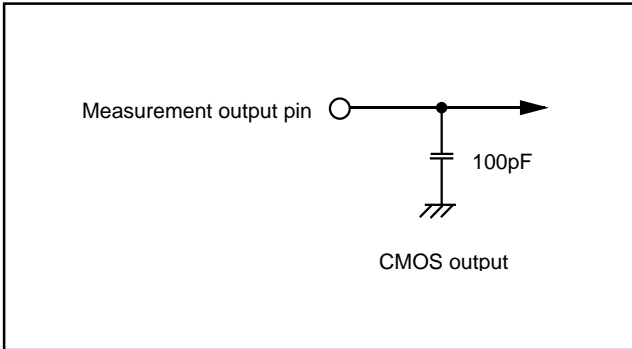

Fig.80 Circuit for measuring output switching characteristics (1)

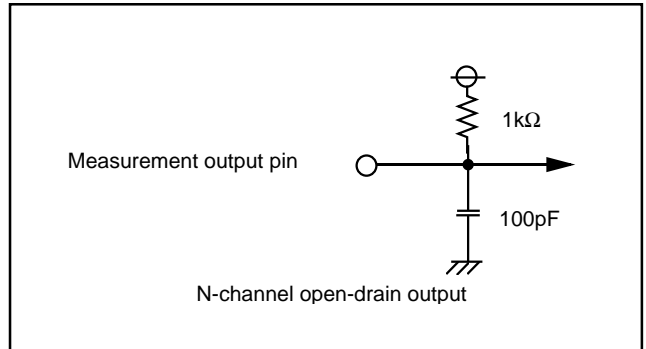

Fig.81 Circuit for measuring output switching characteristics (2)



Single-chip mode timing diagram

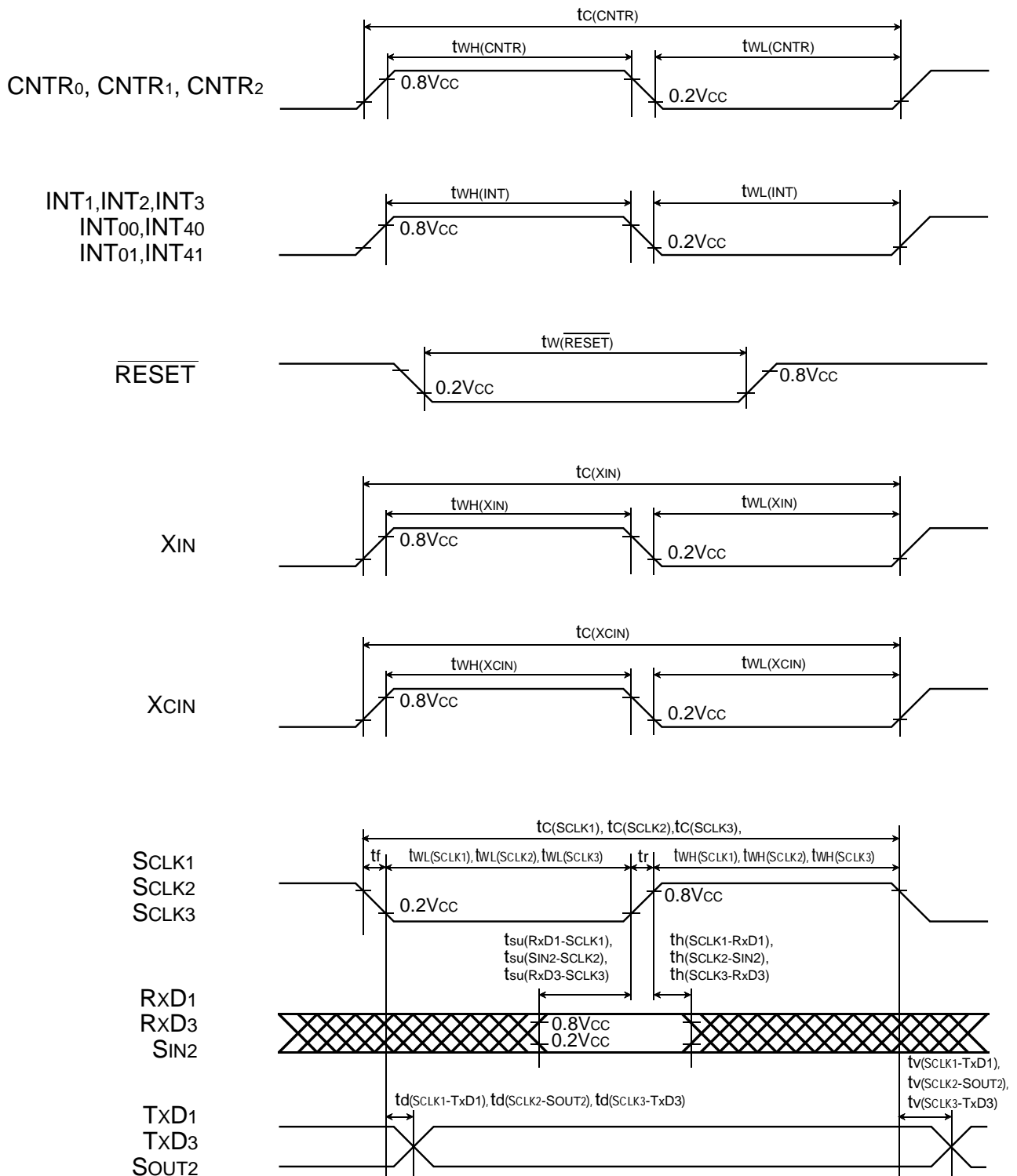
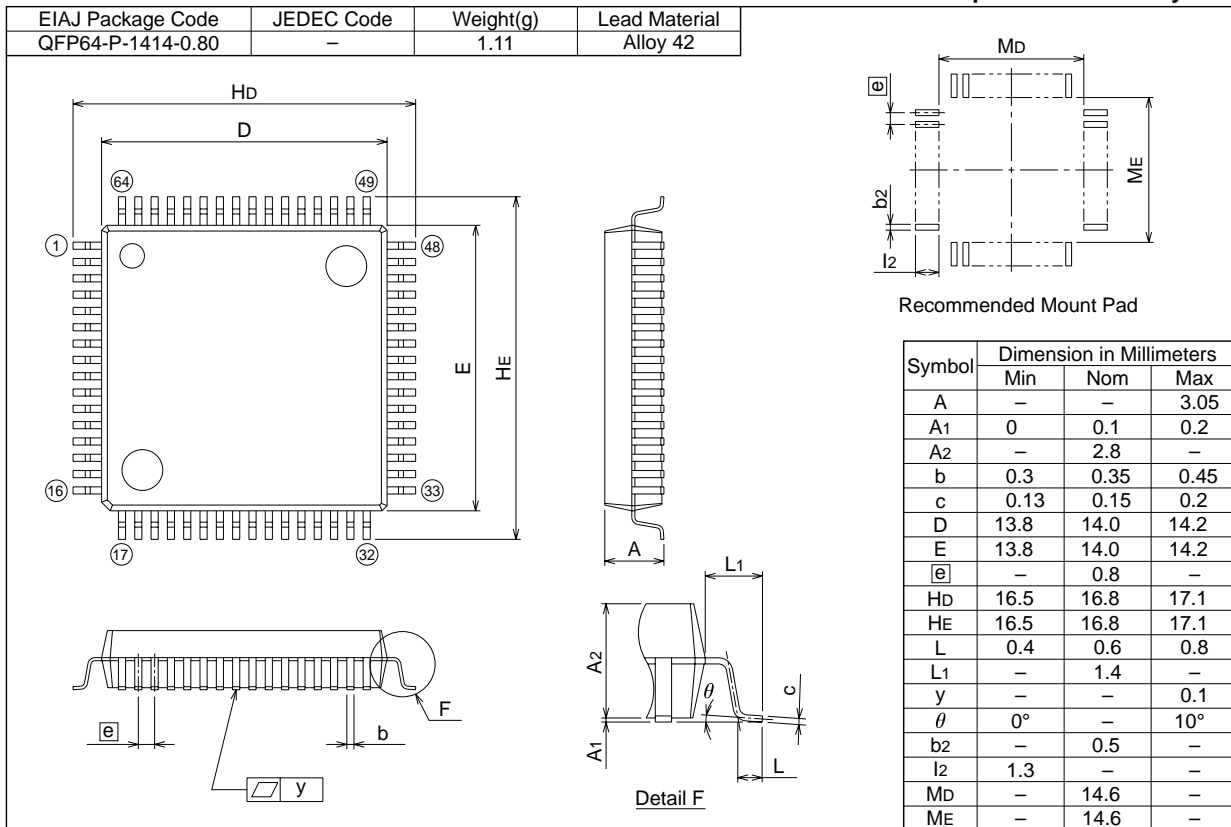

Fig. 82 Timing diagram (in single-chip mode)

PACKAGE OUTLINE

64P6N-A

Plastic 64pin 14X14mm body QFP



64P4B

Plastic 64pin 750mil SDIP

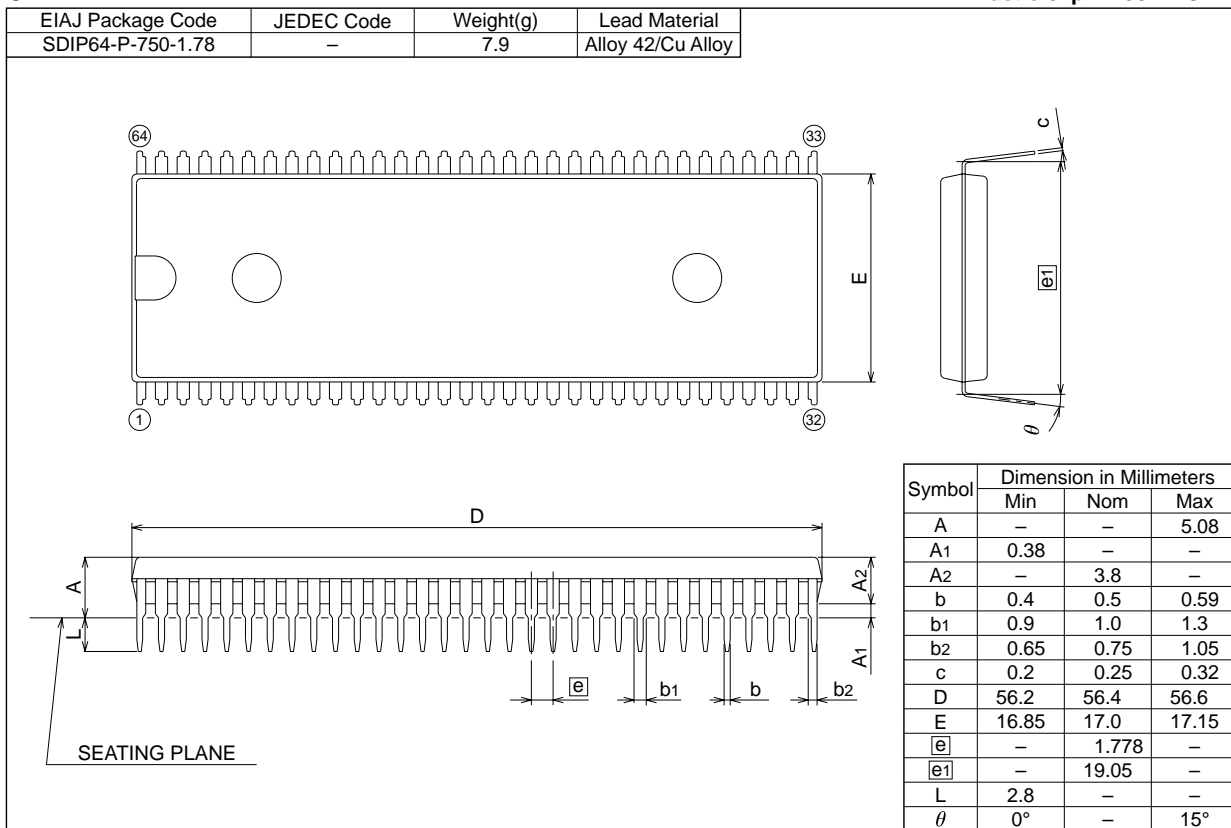

3803 Group (Spec. H)

64P6Q-A

Plastic 64pin 10X10mm body LQFP

EIAJ Package Code	JEDEC Code	Weight(g)	Lead Material
LQFP64-P-1010-0.5	—	—	Cu Alloy

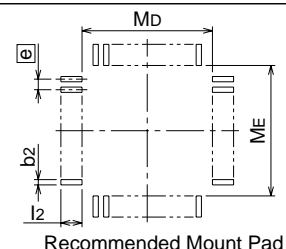
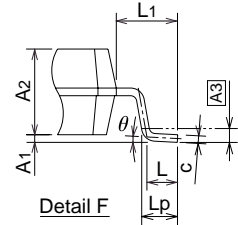
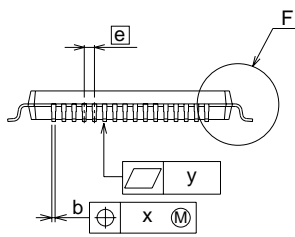
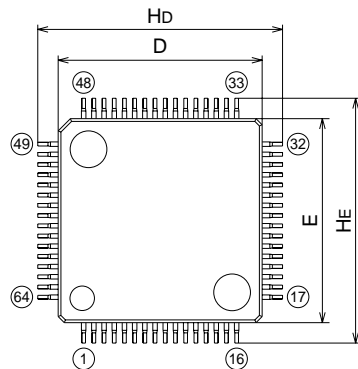

Symbol	Dimension in Millimeters		
	Min	Nom	Max
A	—	—	1.7
A1	0	0.1	0.2
A2	—	1.4	—
b	0.13	0.18	0.28
c	0.105	0.125	0.175
D	9.9	10.0	10.1
E	9.9	10.0	10.1
e	—	0.5	—
Hd	11.8	12.0	12.2
HE	11.8	12.0	12.2
L	0.3	0.5	0.7
L1	—	1.0	—
Lp	0.45	0.6	0.75
A3	—	0.25	—
x	—	—	0.08
y	—	—	0.1
θ	0 <sub>j</sub>	—	10 <sub>j</sub>
b2	—	0.225	—
l2	1.0	—	—
Md	—	10.4	—
ME	—	10.4	—

64P6U-A

Plastic 64pin 14X14mm body LQFP

EIAJ Package Code	JEDEC Code	Weight(g)	Lead Material
LQFP64-P-1414-0.8	—	—	Cu Alloy

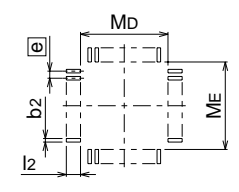
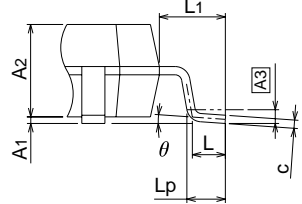
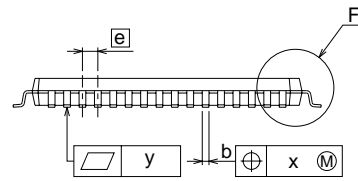
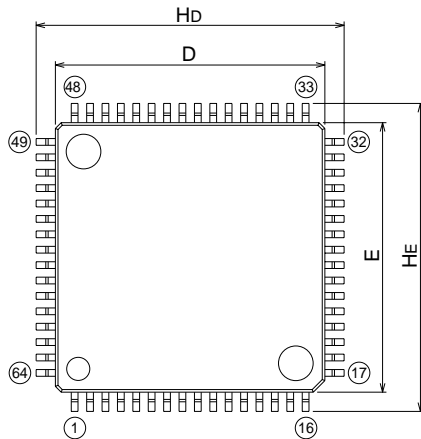

Symbol	Dimension in Millimeters		
	Min	Nom	Max
A	—	—	1.7
A1	0	0.1	0.2
A2	—	1.4	—
b	0.32	0.37	0.45
c	0.105	0.125	0.175
D	13.9	14.0	14.1
E	13.9	14.0	14.1
e	—	0.8	—
Hd	15.8	16.0	16.2
HE	15.8	16.0	16.2
L	0.3	0.5	0.7
L1	—	1.0	—
Lp	0.45	0.6	0.75
A3	—	0.25	—
x	—	—	0.2
y	—	—	0.1
θ	0°	—	8°
b2	—	0.5	—
l2	0.95	—	—
Md	—	14.4	—
ME	—	14.4	—



REVISION HISTORY

3803 Group (Spec.H) Data Sheet

Rev.	Date	Description	
		Page	Summary
1.00	Sep. 3, 2001	–	First edition issued
2.00	May. 28, 2003	1,2,6,7 5 7 23 64  68 69 73  75 75,77 76,78  79	<ul style="list-style-type: none"> <li>•Delete the following : “*:KP package is under development.”</li> <li>•Table 4 pin description VCC,VSS Apply voltage of 2.7–5.5V → 1.8V–5.5V</li> <li>•Fig.5 Memory expansion plan As of Dec. 2002 → As of Mar. 2003</li> <li>•Notes (address 3A16) → (address 003A16), (address 2316) → (address 002316), (address 2A16) → (address 002A16), (address 3916) → (address 003916)</li> <li>•Fig.61 System clock generating circuit block diagram</li> </ul> <ul style="list-style-type: none"> <li>•Table 10 Recommended operating conditions Add : VIL “L” input voltage XIN, XCIN 1.8≤VCC≤5.5V Min. → 0</li> <li>•Table 11 Recommended operating conditions f(XIN) High-speed mode f(φ)=f(XIN)/2 2.2≤VCC≤4.0V → 2.7≤VCC≤4.0V</li> <li>•Table 16 A-D converter characteristics VCC 8bit A-D mode, 10bit A-D mode Max. 5.0 → 5.5</li> <li>•Table 17 D-A converter characteristics VCC = 4.0 to 5.5V → 4.0≤VCC≤5.5V, VCC = 2.7 to 4.0V → 2.7≤VCC&lt;4.0V</li> <li>•Table 16 A-D converter characteristics, Table 17 D-A converter characteristics Resolution Unit Bits → bit</li> <li>•Table 18 Timing requirements (1) (In high-speed mode) tc(XIN) Main clock XIN input cycle time 2.7≤VCC&lt;4.0 Min. 2.6×10<sup>3</sup>/(82VCC-3) → 26×10<sup>3</sup>/(82VCC-3)</li> <li>•Table 18 Timing requirements (1) (In high-speed mode), Table 20 Timing requirements (3) (In middle-speed mode) tWH(XCIN) Sub-clock input “H” pulse width → Sub-clock XCIN input “H” pulse width tWL(XCIN) Sub-clock input “L” pulse width → Sub-clock XCIN input “L” pulse width</li> <li>•Table 19 Timing requirements (2) (In high-speed mode), Table 20 Timing requirements (4) (In middle-speed mode) tCL(SCLK2) → tWL(SCLK2)</li> <li>•Fig.63 Timing diagram (in single-chip mode) Delete the following underline parts : SCLK1 SCLK2 SCLK3 <u>t<sub>f</sub></u>, <u>t<sub>r</sub></u> TXD1 TXD3 SOUT2 <u>td(SCLK1-TXD1)</u>, <u>td(SCLK2-SOUT2)</u>, <u>td(SCLK3-TXD3)</u> <u>tv(SCLK1-TXD1)</u>, <u>tv(SCLK2-SOUT2)</u>, <u>tv(SCLK3-TXD3)</u></li> </ul>
3.00	Oct. 14, 2003		Flash memory version is added.
3.01	Jun.25, 2004	6 15 16	Table 5 Pin description is partly revised. Figure 11 Memory map of special function register (SFR) is partly revised. Table 8 I/O port function is partly revised.

REVISION HISTORY

3803 Group (Spec.H) Data Sheet

Rev.	Date	Description	
		Page	Summary
3.01	Jun.25, 2004	61	Explanations of "RESET CIRCUIT" are partly revised.
		61	Figure 56 Reset circuit example is partly revised.
		63	Explanations of "(1) Stop mode" of "Oscillation control" are partly added.
		65	Figure 56 Reset circuit example is partly revised.
		69	Explanations of "Outline Performance" are partly revised.
		69	Figure 64 Structure of flash memory control register 0 is partly revised.
		70	Figure 66 is partly revised.
		70	Table 11 is partly revised.
		70	Figure 67 is partly revised.
		80	P46 of Table 15 is revised.
		86	"NOTES ON PROGRAMMING" is added.
		87	"DATA REQUIRED FOR MASK ORDERS" is added.
		88	Note of Table 16 is partly revised.
		97	Table 26 A-D converter characteristics (Mask ROM version) is partly revised.
		97	Table 27 D-A converter characteristics (Mask ROM version) is partly revised.
		98	Table 29 A-D converter characteristics (Flash memory version) is partly revised.
		98	Table 30 D-A converter characteristics (Flash memory version) is partly revised.
98	Table 31 Power source circuit timing characteristics (Flash memory version) is added.		
99	tw(RESET) of Table 32 is revised.		
101	Table 33 and Table 34 of Rev.3.00 are eliminated.		
3.02	Nov.05, 2004	1	Memory size ROM....16 K to 32 K bytes → 16 K to 60 K bytes RAM....640 to 1024 bytes → 640 to 2048 bytes
		1,2,5,8,9	WG version is added.
		9	Fig.6 is partly eliminated.
		35	(5) Pulse width measurement mode is partly revised.
		62	Fig.58 is partly revised.
		64	CLOCK GENERATING CIRCUIT is partly revised.
		65	Fig.60 is partly revised.
		66	Note 4 of Fig.62 is added.
		77	Functions To Inhibit Rewriting Flash Memory Version is partly added.
		80	Standard serial I/O Mode is partly revised.
			Outline Performance (Standard Serial I/O Mode) is eliminated.
		95	Table 23 Electrical characteristics (1) "VOL "L" output voltage P20-P27" is added.
		100,101	Table 33 Timing requirements (1), Table 34 Timing requirements (2) (In high-speed mode) is deleted.
		102,103	Mask ROM version: Vcc = 1.8 to 5.5V → Vcc = 2.0 to 5.5V Table 35 Switching characteristics (1), Table 36 Switching characteristics (2) are added.
104	Fig.80 Circuit for measuring output switching characteristics (1), Fig.81 Circuit for measuring output switching characteristics (2) are added.		
105	Fig.82 Timing diagram (in single-chip mode) is revised.		
108	PACKAGE OUTLINE 64F0G is added.		

## Renesas Technology Corp. Sales Strategic Planning Div. Nippon Bldg., 2-6-2, Ohte-machi, Chiyoda-ku, Tokyo 100-0004, Japan

Keep safety first in your circuit designs!

1. Renesas Technology Corp. puts the maximum effort into making semiconductor products better and more reliable, but there is always the possibility that trouble may occur with them. Trouble with semiconductors may lead to personal injury, fire or property damage.  
Remember to give due consideration to safety when making your circuit designs, with appropriate measures such as (i) placement of substitutive, auxiliary circuits, (ii) use of nonflammable material or (iii) prevention against any malfunction or mishap.

Notes regarding these materials

1. These materials are intended as a reference to assist our customers in the selection of the Renesas Technology Corp. product best suited to the customer's application; they do not convey any license under any intellectual property rights, or any other rights, belonging to Renesas Technology Corp. or a third party.
2. Renesas Technology Corp. assumes no responsibility for any damage, or infringement of any third-party's rights, originating in the use of any product data, diagrams, charts, programs, algorithms, or circuit application examples contained in these materials.
3. All information contained in these materials, including product data, diagrams, charts, programs and algorithms represents information on products at the time of publication of these materials, and are subject to change by Renesas Technology Corp. without notice due to product improvements or other reasons. It is therefore recommended that customers contact Renesas Technology Corp. or an authorized Renesas Technology Corp. product distributor for the latest product information before purchasing a product listed herein.  
The information described here may contain technical inaccuracies or typographical errors.  
Renesas Technology Corp. assumes no responsibility for any damage, liability, or other loss rising from these inaccuracies or errors.  
Please also pay attention to information published by Renesas Technology Corp. by various means, including the Renesas Technology Corp. Semiconductor home page (<http://www.renesas.com>).
4. When using any or all of the information contained in these materials, including product data, diagrams, charts, programs, and algorithms, please be sure to evaluate all information as a total system before making a final decision on the applicability of the information and products. Renesas Technology Corp. assumes no responsibility for any damage, liability or other loss resulting from the information contained herein.
5. Renesas Technology Corp. semiconductors are not designed or manufactured for use in a device or system that is used under circumstances in which human life is potentially at stake. Please contact Renesas Technology Corp. or an authorized Renesas Technology Corp. product distributor when considering the use of a product contained herein for any specific purposes, such as apparatus or systems for transportation, vehicular, medical, aerospace, nuclear, or undersea repeater use.
6. The prior written approval of Renesas Technology Corp. is necessary to reprint or reproduce in whole or in part these materials.
7. If these products or technologies are subject to the Japanese export control restrictions, they must be exported under a license from the Japanese government and cannot be imported into a country other than the approved destination.  
Any diversion or reexport contrary to the export control laws and regulations of Japan and/or the country of destination is prohibited.
8. Please contact Renesas Technology Corp. for further details on these materials or the products contained therein.



### RENESAS SALES OFFICES

<http://www.renesas.com>

Refer to "<http://www.renesas.com/en/network>" for the latest and detailed information.

#### **Renesas Technology America, Inc.**

450 Holger Way, San Jose, CA 95134-1368, U.S.A  
Tel: <1> (408) 382-7500, Fax: <1> (408) 382-7501

#### **Renesas Technology Europe Limited**

Dukes Meadow, Millboard Road, Bourne End, Buckinghamshire, SL8 5FH, U.K.  
Tel: <44> (1628) 585-100, Fax: <44> (1628) 585-900

#### **Renesas Technology Hong Kong Ltd.**

7th Floor, North Tower, World Finance Centre, Harbour City, 1 Canton Road, Tsimshatsui, Kowloon, Hong Kong  
Tel: <852> 2265-6688, Fax: <852> 2730-6071

#### **Renesas Technology Taiwan Co., Ltd.**

10th Floor, No.99, Fushing North Road, Taipei, Taiwan  
Tel: <886> (2) 2715-2888, Fax: <886> (2) 2713-2999

#### **Renesas Technology (Shanghai) Co., Ltd.**

Unit2607 Ruijing Building, No.205 Maoming Road (S), Shanghai 200020, China  
Tel: <86> (21) 6472-1001, Fax: <86> (21) 6415-2952

#### **Renesas Technology Singapore Pte. Ltd.**

1 Harbour Front Avenue, #06-10, Keppel Bay Tower, Singapore 098632  
Tel: <65> 6213-0200, Fax: <65> 6278-8001