**Features**

- Fast Acquisition: 100ns wide 1V pulse, 200ns wide 10V pulse
- High Slew Rate: 50 V/ μ s
- Low Droop Rate: 1 mV/ μ s max with $C_x = 1000\text{pF}$
- Wide Temperature Operation: -55°C to $+125^\circ\text{C}$ (AH503DS)

Applications

- Data Acquisition
- Pulse Stretcher
- Noise Measurement
- Video Peak Sense

The AH503 and AH504 peak detectors are designed for rapid acquisition of very narrow pulses. They combine high slew rates and fast settling to capture individual 1V pulses as narrow as 100ns to within $\pm 10\text{mV}$. For general applications where narrow pulses need to be acquired for analysis or processing, the lower cost AH503DK is ideal. Where the time interval for the sampling needs to be more precisely defined, the faster reset and switching times of the AH504DK may be required. When operation over the full MIL temperature range is required (-55°C to $+125^\circ\text{C}$), the AH503DS, with slightly higher droop rate, will be appropriate.

The AH503 and AH504, in standard 14 pin ceramic DIP packages, reduce board space 90% over the only previously available peak detectors in this speed range. Use of standard thin-film hybrid technology also enhances the reliability of these devices.

The only external component required for capturing pulses with the AH503 and AH504 is the hold capacitor, which the designer needs to optimize for the particular application, considering the trade-off between acquisition time and memory decay rate. This helps minimize design time and simplify overall circuit design.

AH503/AH504 Specifications

Specifications at $T_A = +25^\circ\text{C}$ and $V_{CC} = \pm 15\text{V DC}$ unless otherwise specified

Parameter	Condition	www.DataSheet4U.com			Units
		AH503DK	AH504DK	AH503DS	
Input					
Voltage	$V_{in} = 1\text{MHz AC}, C_x = 1000\text{pF}$ Sensing Range, $T_A = +25^\circ\text{C}$ Sensing Range, $T_A = \text{Full}$ Operating Range	+0.03/+10	*	*	V_{min} range
Resistance	Gate Lo Gate Hi	1 500	*	*	$K\Omega$ min $K\Omega$ typ
Reset Command	$T_A = \text{Full Operating Range}$	0.8	*	*	V_{max}
Gate Open	$T_A = \text{Full Operating Range}$	0.8	*	*	V_{max}
Peak Sense Command	$T_A = \text{Full Operating Range}$	2.4	*	*	V_{min}
Command Load	Gate = Reset = 0V or 5V $T_A = \text{Full Operating Range}$	2	*	*	mA max
Output					
Voltage	$V_{in} = 10\text{V peak AC}, 1\text{MHz}$ $C_x = 330\text{pF}, R_L = 1K\Omega$ $T_A = \text{Full Operating Range}$	9.9 9.8	*	*	V_{min} V_{min}
Current	$V_{out} = +10\text{V}$	10	*	*	mA min
Resistance		1	*	*	Ω typ
Overshoot	$V_{in} = +10\text{V step}, C_x = 330\text{pF}$	10	*	*	% typ
Dynamic Response					
Slew Rate	$C_x = 100\text{pF}$ -3dB point, $V_{in} = 5\text{V peak AC},$ $R_L = 1K\Omega, C_x = 330\text{pF}$	50 10	*	*	$V/\mu\text{s}$ typ MHz min
Continuous Sinusoidal	$T_A = \text{Full Operating Range}$	9.5	*	*	MHz min
Acquisition Time (Minimum Pulse Width)	$V_{in} = 10\text{V pulse}, C_x = 330\text{pF}$ $R_L = 1K\Omega$, Settling to within $\pm 100\text{mV}$ $T_A = \text{Full Operating Range}$	200	*	*	ns max
Reset Time	$V_{in} = 1\text{V pulse}, C_x = 100\text{pF}$ $R_L = 1K\Omega$, Settling to within $\pm 10\text{mV}$	100	*	*	ns max
Gate Turn On Time	$V_{out} = +10\text{V to under } +30\text{mV},$ $C_x = 330\text{pF}, \text{Gate} = \text{Lo}$	500	300	500	ns max
Gate Turn Off Time	$V_{in} = +10\text{V DC}, \text{Reset} = \text{Hi},$ Observe at C_x	500	300	500	ns max
	$V_{in} = +10\text{V DC}, \text{Reset} = \text{Hi},$ Observe at input	500	300	300	ns max
Error Sources					
Offset Voltage	Reset = Lo $T_A = \text{Full Operating Range}$	± 30	*	*	mV max
Gain Error	$V_{in} = +10\text{V DC}, C_x = 330\text{pF},$ $R_L = 1K\Omega$ $T_A = \text{Full Operating Range}$	± 0.5 ± 1	*	*	% max % max
Memory Decay Rate					
	$C_x = 1000\text{pF}$	1	1	7	$\text{mV}/\mu\text{s}$ max
	$T_A = \text{Full Operating Range}$	2	2	7	$\text{mV}/\mu\text{s}$ max
Temperature Range					
Operating		0/70	0/70	-55/125	$^\circ\text{C}$
Derated Performance		-25/100	-25/100	-55/125	$^\circ\text{C}$
Storage		-65/150	*	*	$^\circ\text{C}$
Power Supply Requirements					
Rated Voltage		± 15	*	*	V
Operating Range		$\pm 9/\pm 18$	*	*	V
Quiescent Current	$T_A = \text{Full Operating Range}$	+30/-10	+35/-15	+30/-10	mA max

Typical Performance Curves

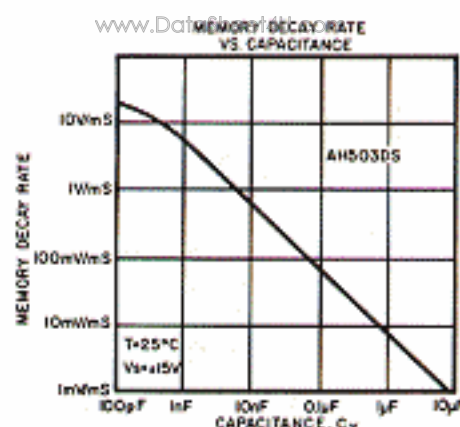
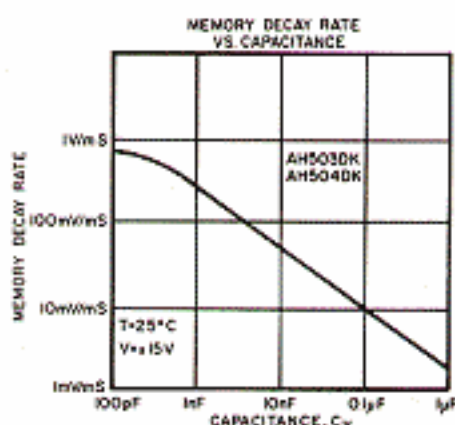
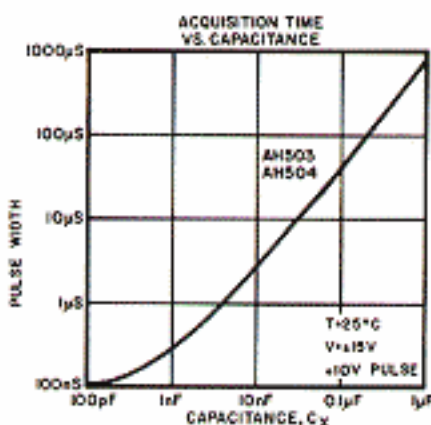

Mechanical Description

The AH503/AH504 package is a standard 14-pin bottom brazed ceramic dual-in-line package. The AH503DS is hermetically sealed.

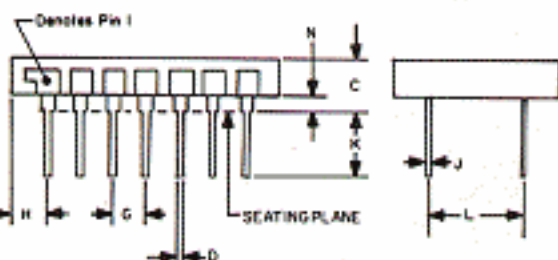
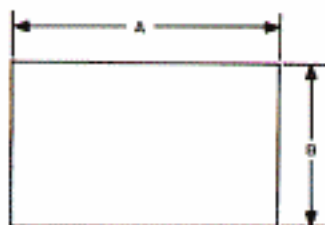

Bottom View

Pin Numbers shown for reference only. Numbers are not marked on Package.

- 1) Reset
- 2) Gate
- 3) No Connection (NC)
- 4) Digital Common
- 5) NC
- 6) Analog Common
- 7) Offset Adjust
- 8) Analog Output
- 9) Offset Adjust

O14	10
O13	20
O12	30
O11	40
O10	50
O9	60
O8	70

- 10) C_x
- 11) +V_{CC}
- 12) NC
- 13) Analog input
- 14) -V_{CC}

Dim	Inches		Millimeters	
	Min	Max	Min	Max
A	.770	.810	19.56	20.57
B	.480	.500	12.19	12.70
C	.155	.215	3.94	5.46
D	.016	.020	.41	.51
G	0.100 Nom.		2.54 Nom.	
H	.080	.110	2.03	2.79
J	.009	.012	.23	.30
K	.150	.210	3.81	5.33
L	.300 Nom.		7.62 Nom.	
N	.015	.035	.38	.89

Note

1) Leads in true position within .010" (.255 mm)

Absolute Maximum Ratings

Supply	± 20V DC
Input Voltage ¹	± 15V DC
Storage Temperature Range	- 65°C to 150°C
Operating Temperature Range	- 55°C to 125°C
Lead Temperature (Soldering 10 seconds)	+ 300°C
Output Short Circuit Duration ²	Continuous

Notes

- 1) For supply voltages less than ± 15V DC, the absolute maximum input is equal to the supply voltage.
- 2) Short circuit to ground only.

Application Information

Figure 1: Functional Block Diagram

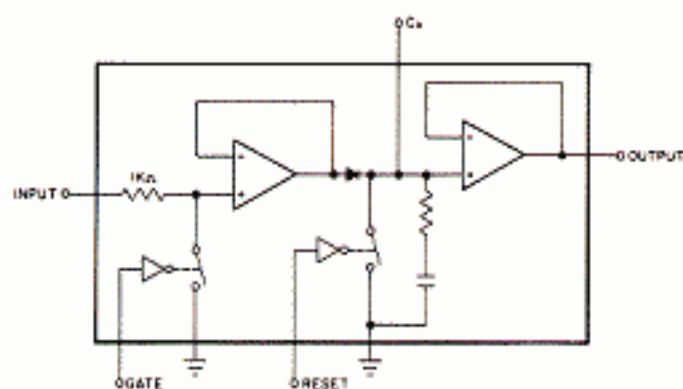

The basic difference between the AH503 and the AH504 is the speed of the internal switches used for gating and resetting the unit. The AH504 resets and gates approximately 40% faster than the AH503, allowing the user to more precisely define the specific time interval when peak detection is required.

To provide predictable, reliable performance from -55°C to 125°C , the AH503DS had to be modified internally. The required modification also resulted in an increased memory decay rate, as specified. When actual operating temperatures do not exceed 100°C , the AH503DK is preferable.

Basic Operation

Figure 1 shows a block diagram of the basic operation of the AH503 and AH504. A diode is incorporated internally to prevent damage to the circuit from negative inputs. The two amplifier stages are each in a unity-gain follower configuration, to provide an accurate overall gain of 1. The diode shown after the input amp (actually an open-collector arrangement) allows the hold capacitor to track positive-going signals, but blocks negative-going signals. Once the peak is acquired, the FET input of the output amplifier minimizes the rate of discharge of the hold capacitor.

Acquisition time on the AH503 and AH504 relates to the width of the pulse they can capture, and not to the timing of the output. Typically, the delay between the input reaching peak value and the output settling to that value will be 500ns. This obviously varies with the value of the hold capacitor, C_{H} , and needs to be considered in overall circuit timing.

Figure 2: Timing Diagram

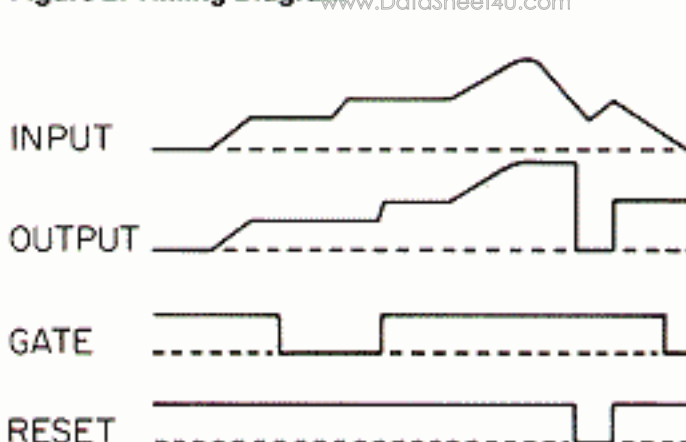

Figure 2 shows the basic timing of the AH503 and AH504. With the gate and reset high, the output will track the input as long as it goes positive. Changing the gate to low blocks further input rises from charging the hold capacitor. When the gate returns high, the output again tracks a positive-going input, and holds the peak level attained (disregarding the memory decay rate) until reset.

The gate and reset switches require standard TTL logic levels, and both switches are normally closed. Whenever possible, the input gate should be closed (logic level low) when resetting (also logic level low) since a positive input signal when resetting could prevent the hold capacitor from fully discharging.

For optimum operation, the end of the reset command should precede the end of the gate command by approximately 150ns. This timing is only critical when the target pulse can occur within 150ns of activating the gate to start sensing.

While all of the applications shown below are designed to capture pulses which are positive relative to ground, pin 6 (Analog Common) can actually be used to set a threshold level, above which any pulse would be captured. Pin 6 can even be tied to a negative voltage, as long as the delta between pin 6 and $+V_{\text{CC}}$ does not exceed 20V.

Figure 3: Typical +10V Pulse Application

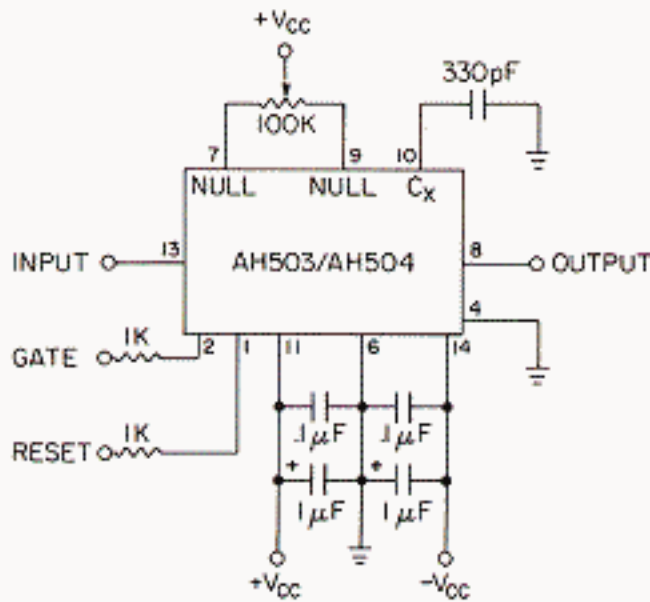
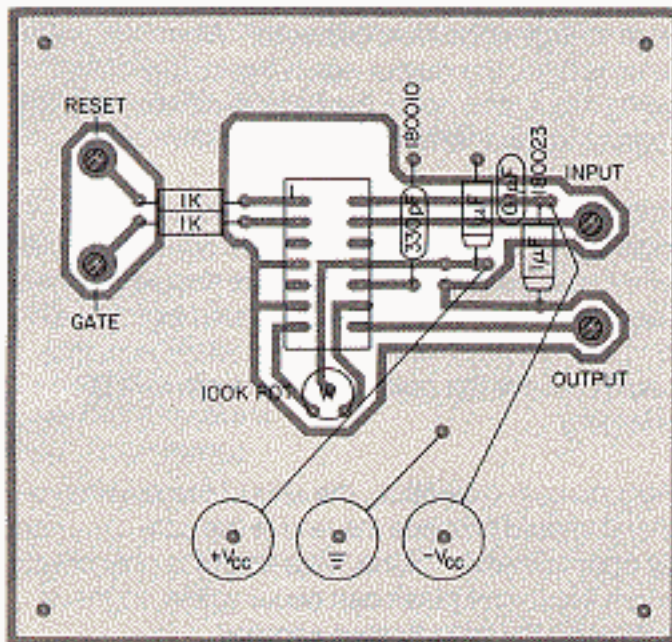

Figure 4: Suggested Board Layout



Circuit Layout

A typical circuit for the AH503 and AH504 is shown in Figure 3, with an appropriate printed circuit board layout shown in Figure 4.

A hold capacitor, C_x , of 330pF is optimal for acquiring a full +10V pulse, when slew rate, settling time, overshoot, etc., are all considered. For smaller pulses, the hold capacitor can be reduced, hence reducing acquisition time without sacrificing accuracy.

Figure 5: Peak Detector With Gain

www.DataSheet4U.com

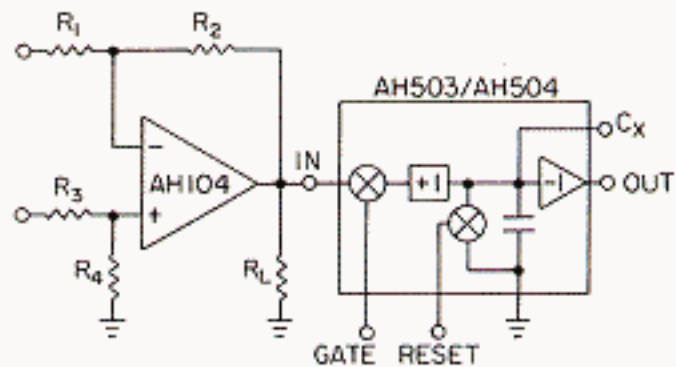

As on any high speed device, grounding is critical on the AH503 and AH504. Whenever possible, a ground plane should be used, covering as much of the circuit board as possible to provide low resistance and low impedance paths for all signal and power common returns.

If the digital supplies or common are susceptible to surges, as is common in digital systems, the digital and analog grounds need to be isolated, and power supply bypassing becomes critical.

Power supply bypassing should be used in all applications, since the AH503 and AH504 are not internally bypassed. The capacitors needed will depend on the quality of the supply, but in any case, the bypassing should be done as close as possible to the device pins.

Offset Null

If detection of peaks below +30mV is needed, the offset null circuit shown in Figure 3 can be used. Sine waves as low as +10mV peak have been captured in this method.

Adjustment should be done with the input grounded, after a reset command and with gate and reset both at +5V, so that the trimming can also adjust out any digital feed through from the logic signals.

