

## MECHANICAL DATA

Dimensions in mm.

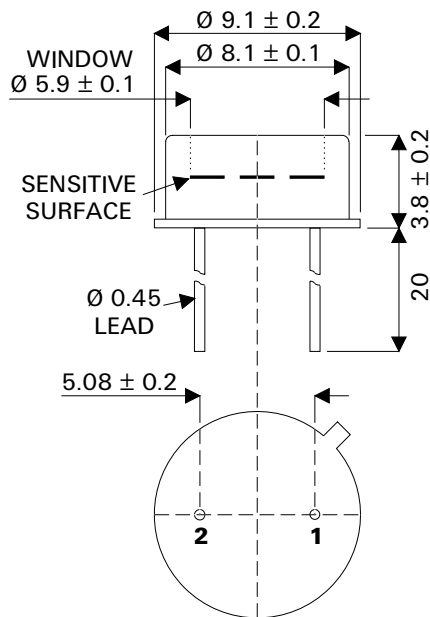

### TO-39 Package

Pin 1 – Anode

Pin 2 – Cathode & Case

## P.I.N. PHOTODIODE

### FEATURES

- ASYMMETRIC RECEIVING ANGLES
- EYE RESPONSE DETECTION
- EXCELLENT LINEARITY
- LOW NOISE
- WIDE SPECTRAL RESPONSE
- LOW LEAKAGE CURRENT
- LOW CAPACITANCE
- BG18 INTEGRAL OPTICAL FILTER
- TO39 HERMETIC METAL CAN PACKAGE
- EMI SCREENING MESH AVAILABLE

### DESCRIPTION

The SMP525G-FL is a Silicon P.I.N. photodiode incorporated in a hermetic metal can package. The electrical terminations are via two leads of diameter 0.018" on a pitch centre diameter of 0.2". The can structure incorporates an photoptic response optical filter with peak transmission at 510nm. The cathode of the photodiode is electrically connected to the package.

The photodiode active area provides asymmetric viewing angles in two orthogonal directions. The photodiode structure has been optimised for high sensitivity, asymmetric light measurement applications. The metal can and optional screening mesh ensure a rugged device with a high degree of immunity to radiated electrical interference.

### ABSOLUTE MAXIMUM RATINGS (T<sub>case</sub> = 25°C unless otherwise stated)

Operating temperature range	-40°C to +70°C
Storage temperature range	-45°C to +80°C
Temperature coefficient of responsivity	0.35% per °C
Temperature coefficient of dark current	x2 per 8°C rise
Reverse breakdown voltage	60V

**CHARACTERISTICS** ( $T_{amb}=25^{\circ}\text{C}$  unless otherwise stated)

Characteristic	Test Conditions.	Min.	Typ.	Max.	Units
Responsivity	$\lambda$ at 900nm	0.45	0.55		A/W
Active Area			2.05		mm <sup>2</sup>
Dark Current	E = 0 Dark 1V Reverse		0.25	4	nA
	E = 0 Dark 10V Reverse		4	10	
Breakdown Voltage	E = 0 Dark 10 $\mu$ A Reverse	60	80		V
Capacitance	E = 0 Dark 0V Reverse		45		pF
	E = 0 Dark 20V Reverse		6		
Rise Time	30V Reverse 50 $\Omega$				ns
NEP	900nm			0.45	W/ $\sqrt{\text{Hz}}$

**Spectral Response**

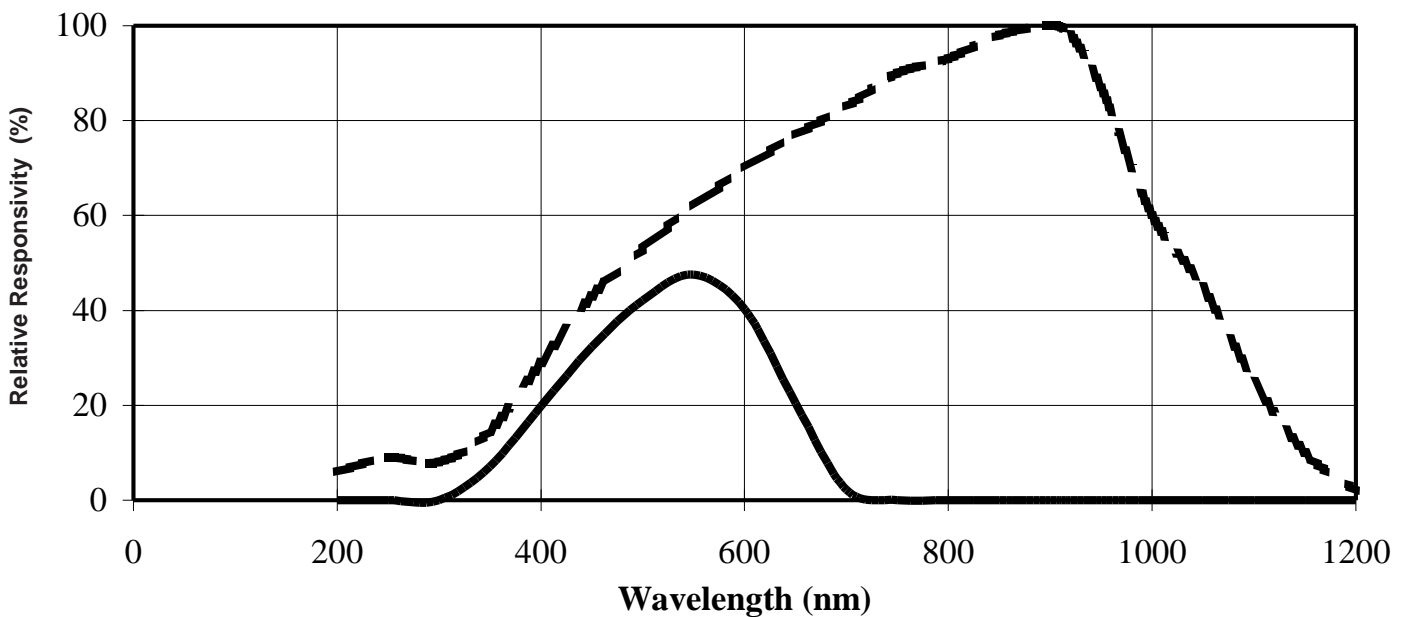

**Directional Characteristics**

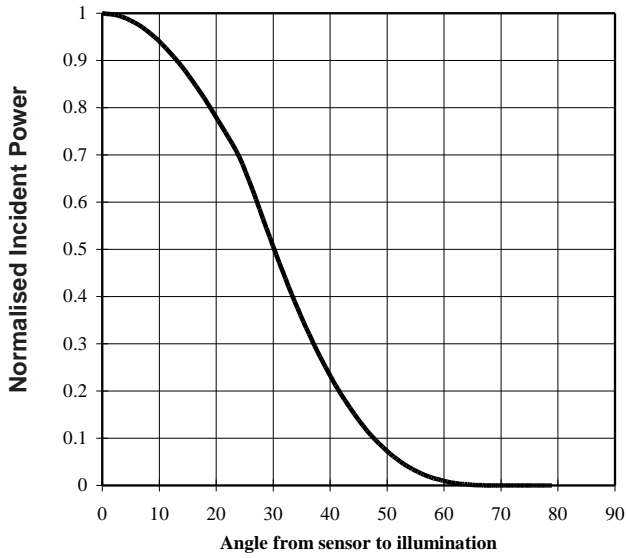

**Directional Characteristics**

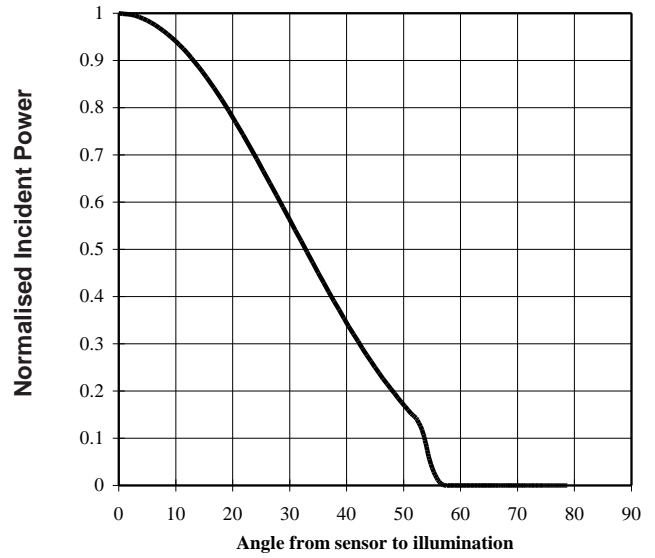

**Directional characteristics**

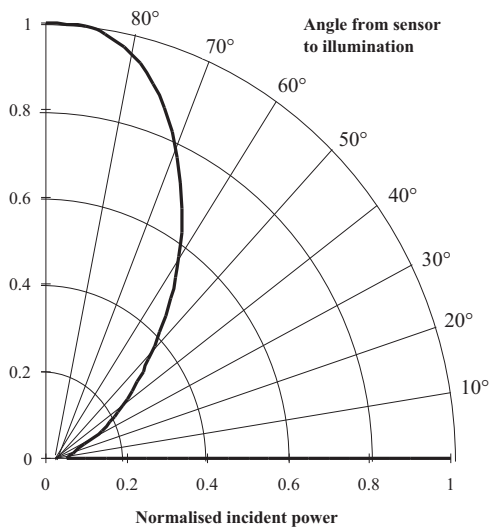

**Directional characteristics**

