

Product Specification

www.DataSheet4U.com

SPECIFICATION FOR APPROVAL

(●) Preliminary Specification

() Final Specification

Title	42.0" WUXGA TFT LCD
-------	---------------------

BUYER	
MODEL	

SUPPLIER	LG.Philips LCD Co., Ltd.
*MODEL	LC420WU2
SUFFIX	SLA1 (RoHS Verified)

*When you obtain standard approval,
please use the above model name without suffix

APPROVED BY	SIGNATURE DATE
/	
/	
/	

APPROVED BY	SIGNATURE DATE
J.H.Yoon / Senior.Manager	
REVIEWED BY	
B. Y. Park / Manager	
PREPARED BY	
K.W.Yang / Engineer	

Please return 1 copy for your confirmation with
your signature and comments.

**TV Product Development Dept.
LG. Philips LCD Co., Ltd**

Product Specification
CONTENTS
www.DataSheet4U.com

Number	ITEM	Page
	COVER	1
	CONTENTS	2
	RECORD OF REVISIONS	3
1	GENERAL DESCRIPTION	4
2	ABSOLUTE MAXIMUM RATINGS	5
3	ELECTRICAL SPECIFICATIONS	6
3-1	ELECTRICAL CHARACTERISTICS	6
3-2	INTERFACE CONNECTIONS	8
3-3	SIGNAL TIMING SPECIFICATIONS	12
3-4	SIGNAL TIMING WAVEFORMS	13
3-5	COLOR DATA REFERENCE	14
3-6	POWER SEQUENCE	15
4	OPTICAL SPECIFICATIONS	17
5	MECHANICAL CHARACTERISTICS	21
6	RELIABILITY	24
7	INTERNATIONAL STANDARDS	25
7-1	SAFETY	25
7-2	EMC	25
8	PACKING	26
8-1	DESIGNATION OF LOT MARK	26
8-2	PACKING FORM	26
9	PRECAUTIONS	27
9-1	MOUNTING PRECAUTIONS	27
9-2	OPERATING PRECAUTIONS	27
9-3	ELECTROSTATIC DISCHARGE CONTROL	28
9-4	PRECAUTIONS FOR STRONG LIGHT EXPOSURE	28
9-5	STORAGE	28
9-6	HANDLING PRECAUTIONS FOR PROTECTION FILM	28

Product Specification

1. General Description

www.DataSheet4U.com

The LC420WU2 is a Color Active Matrix Liquid Crystal Display with an integral Cold Cathode Fluorescent Lamp(CCFL) backlight system. The matrix employs a-Si Thin Film Transistor as the active element. It is a transmissive display type which is operating in the normally black mode. It has a 42.02 inch diagonally measured active display area with WUXGA resolution (1080 vertical by 1920 horizontal pixel array). Each pixel is divided into Red, Green and Blue sub-pixels or dots which are arrayed in vertical stripes. Gray scale or the luminance of the sub-pixel color is determined with a 8-bit gray scale signal for each dot. Therefore, it can present a palette of more than 16.7M(true) colors.

It has been designed to apply the 8-bit 2-port LVDS interface.

It is intended to support LCD TV, PCTV where high brightness, super wide viewing angle, high color gamut, high color depth and fast response time are important.

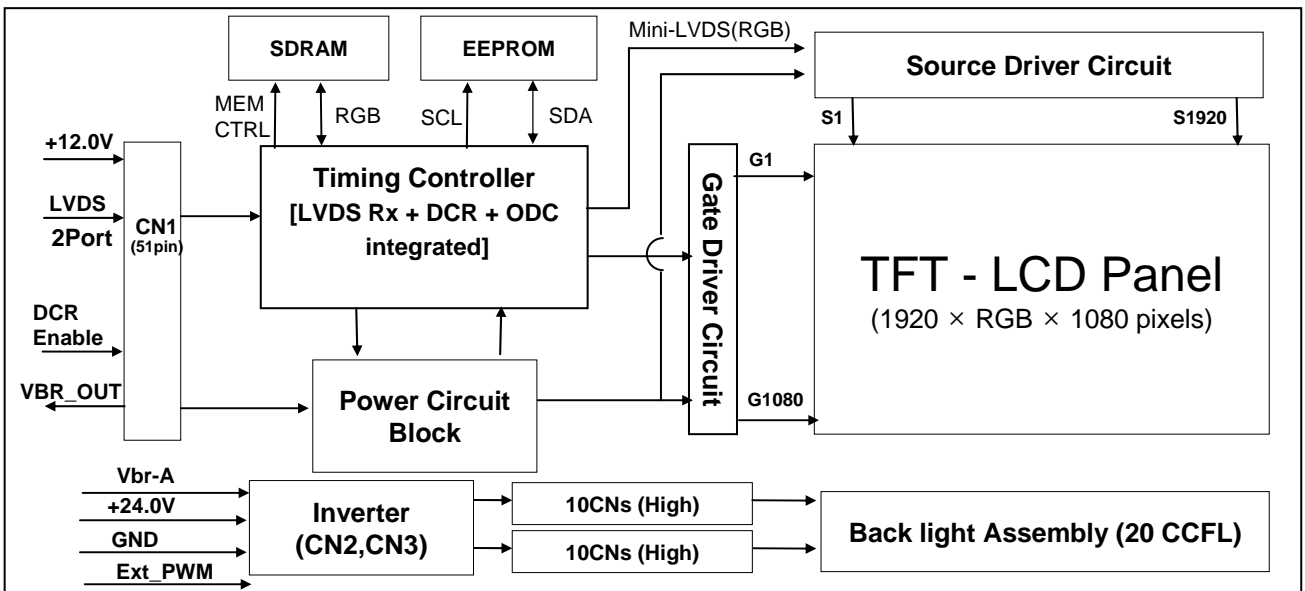

General Features

Active Screen Size	42.02 inches(1067.31mm) diagonal
Outline Dimension	983.0(H) x 576.0 (V) x 51.0 mm(D) (Typ.)
Pixel Pitch	0.4845 mm x 0.4845 mm
Pixel Format	1920 horiz. by 1080 vert. Pixels, RGB stripe arrangement
Color Depth	8-bit, 16.7 M colors
Luminance, White	550 cd/m ² (Center 1point ,Typ.)
Viewing Angle (CR>10)	Viewing angle free (R/L 178 (Typ.), U/D 178 (Typ.))
Power Consumption	Total 167.3 W (Typ.) (Logic=7.3 W, Inverter=160W [I _{BL} =6.0 mA])
Weight	13.0K g (Typ.)
Display Mode	Transmissive mode, Normally black
Surface Treatment	Hard coating(3H), Anti-glare treatment of the front polarizer (Haze 13%)

Product Specification

www.DataSheet4U.com

2. Absolute Maximum Ratings

The following items are maximum values which, if exceeded, may cause faulty operation or damage to the LCD module.

Table 1. ABSOLUTE MAXIMUM RATINGS

Parameter		Symbol	Value		Unit	Remark
			Min	Max		
Power Input Voltage	LCM	VLCD	-0.3	+14.0	Vdc	at 25 ± 2 °C
	Backlight inverter	VBL	+21.6	+28.0	Vdc	
ON/OFF Control Voltage		VON/OFF	-0.3	+5.25	Vdc	
Brightness Control Voltage		VBr	0	+5.0	Vdc	
Operating Temperature		TOP	0	+50	°C	Note 1
Storage Temperature		TST	-20	+50	°C	
Operating Ambient Humidity		HOP	10	90	%RH	
Storage Humidity		HST	10	90	%RH	

Note : 1. Temperature and relative humidity range are shown in the figure below.
Wet bulb temperature should be 39 °C Max. and no condensation of water.
2. Gravity mura can be guaranteed under 40 °C condition.

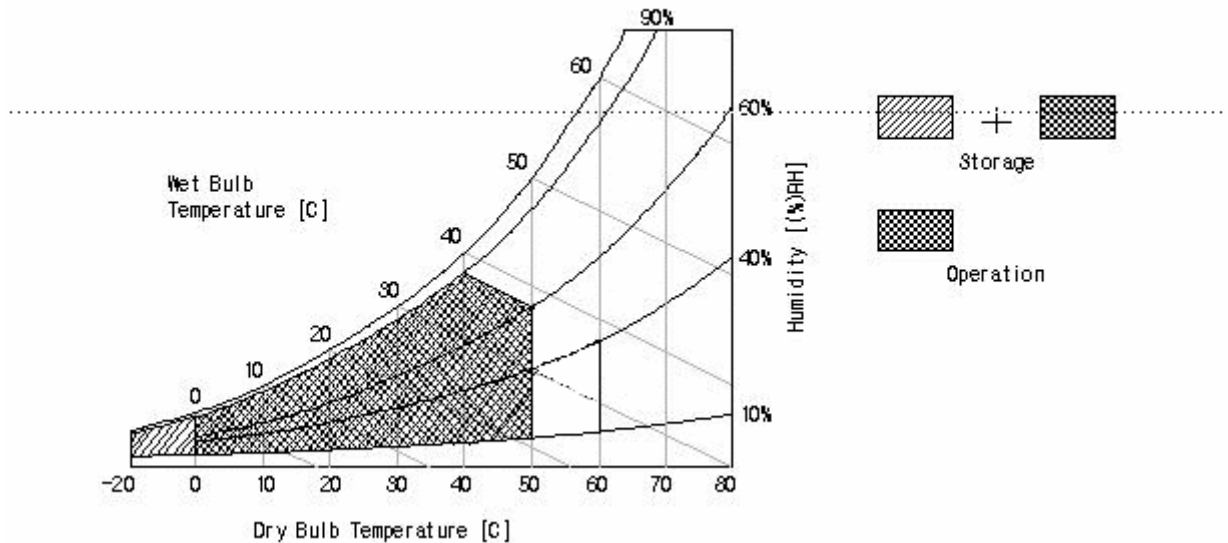

Product Specification

www.DataSheet4U.com

3. Electrical Specifications

3-1. Electrical Characteristics

It requires two power inputs. One is employed to power for the LCD circuit. The other is used for the CCFL backlight and inverter circuit.

Table 2. ELECTRICAL CHARACTERISTICS

Parameter	Symbol	Value			Unit	Note
		Min	Typ	Max		
Circuit :						
Power Input Voltage	V _{LCD}	11.4	12.0	12.6	V _{DC}	
Power Input Current	I _{LCD}	-	610	793	mA	1
		-	820	1066	mA	2
Power Consumption	P _{LCD}	-	7.3	9.5	Watt	1
Rush current	I _{RUSH}	-	-	3.0	A	3

- Note :
1. The specified current and power consumption are under the $V_{LCD}=12.0V$, $25 \pm 2^{\circ}C$, $f_v=60Hz$ condition whereas mosaic pattern(8 x 6) is displayed and f_v is the frame frequency.
 2. The current is specified at the maximum current pattern.
 3. The duration of rush current is about 2ms and rising time of power input is 1ms (min.).

White : 255Gray
Black : 0Gray

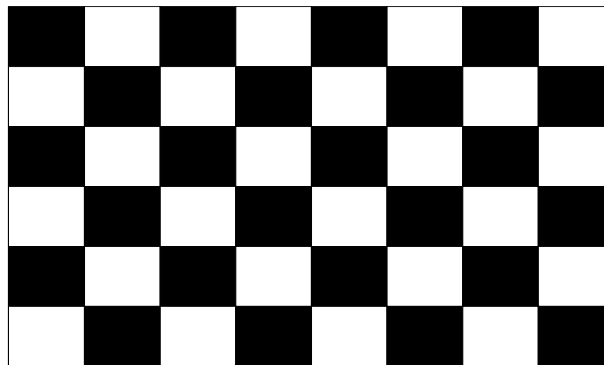

Mosaic Pattern(8 x 6)

Product Specification
Table 3. ELECTRICAL CHARACTERISTICS (Continued)

Parameter	Symbol	Values			Unit	Notes		
		Min	Typ	Max				
Inverter :								
Power Supply Input Voltage	VBL	22.8	24.0	26.2	Vdc	1		
Unloading Input Voltage				28	Vdc			
Power Supply Input Voltage Ripple		-0.2		0.2	Vp-p	1		
Power Supply Input Current	IBL	-	6.7	7.3	A	ExtVbr-B = 100% Boost = 1.65V 1		
		-	7.9	8.5	A	ExtVbr-B = 100% Boost = 3.3V 1		
Power Supply Input Current(In-Rush)	Irush	-	-	13	A	VBL = 22.8V EXTVbr-B=100% Boost = 1.65V 5		
Power Consumption	PBL	-	160	175	W	1		
Input Voltage for Control System Signals	Brightness Adjust	VBR	0.0	-	3.3	Vdc	2	
	On/Off	On	V on	2.5	-	5.0	Vdc	
		Off	V off	-0.3	0.0	0.8	Vdc	
Brightness Adj(Burst mode)	EXTVbr-B	20		100	%			
PWM Frequency for NTSC & PAL	NTSC/PAL	145		245	Hz	3		
Pulse Duty(PWM) (Burst mode)	High Level	2.5	-	5.0	V _{DC}			
	Low Level	0.0	-	0.6	V _{DC}			
Lamp Voltage (ExtVbr-B = 100%)	Vout	480	610	760	V(rms)	Boost = Typ		
Lamp Current (ExtVbr-B = 100%)	IO-MAX	6.5	7.0	7.5	mA(rms)	Boost = Max		
	IO-TYP	5.5	6.0	6.5	mA(rms)	Boost = TYP		
	IO-MIN	4.5	5.0	5.5	mA(rms)	Boost = Min		
Life Time	Boost =1.65V	50,000			Hrs	4		
	Boost = 3.3V	40,000						

Notes :

- Electrical characteristics are determined after the unit has been 'ON' and stable for approximately 120 minutes at $25 \pm 2^\circ\text{C}$. The specified current and power consumption are under the typical supply Input voltage 24V and Vbr 1.65V, it is total power consumption. The ripple voltage of the power supply input voltage is under 0.4 Vp-p. LPL recommend Input Voltage is $24.0V \pm 5\%$.
- Brightness Control. This VBR Voltage control brightness.

VBR Voltage	Function
3.3V	Maximum Brightness (110%)
0V	Minimum Brightness (90%)

- LPL recommend that the PWM freq. is synchronized with the treble harmonic of Vsync signal of system.
- Specified Values are for a single lamp which is aligned horizontally.
The life Time is determined as the time which luminance of the lamp is 50% compared to that of initial value at the typical/ maximum lamp current (Boost = 1.65V / 3.3V) on condition of continuous operating at $25 \pm 2^\circ\text{C}$
- The duration of rush current is about 10ms.

Product Specification

3-2. Interface Connections

www.DataSheet4U.com

This LCD module employs two kinds of interface connection, a 51-pin connector is used for the module electronics and two 12-pin connectors are used for the integral backlight system.

3-2-1. LCD Module

- LCD Connector(CN1): FI-R51S-HF(manufactured by JAE) or KN25-51P-0.5SH(manufactured by Hirose)
- Mating Connector : FI-R51HL(JAE) or compatible

Table 4. MODULE CONNECTOR(CN1) PIN CONFIGURATION

No	Symbol	Description	No	Symbol	Description
1	Reserved(NC)	No connection	27	GND	GND
2	Reserved (NC)	No connection(Reserved for I ² C)	28	RE0N	SECOND CHANNEL 0-
3	Reserved (NC)	No connection(Reserved for I ² C)	29	RE0P	SECOND CHANNEL 0+
4	Reserved (NC)	No connection	30	RE1N	SECOND CHANNEL 1-
5	Reserved (NC)	No connection	31	RE1P	SECOND CHANNEL 1+
6	Reserved (NC)	No connection	32	RE2N	SECOND CHANNEL 2-
7	Reserved (NC)	No connection	33	RE2P	SECOND CHANNEL 2+
8	Reserved (NC)	No connection	34	GND	Ground
9	Reserved (NC)	No connection	35	RECLKN	SECOND CLOCK CHANNEL C-
10	Reserved (NC)	No connection	36	RECLKP	SECOND CLOCK CHANNEL C+
11	GND	Ground	37	GND	Ground
12	RO0N	FIRST CHANNEL 0-	38	RE3N	SECOND CHANNEL 3-
13	RO0P	FIRST CHANNEL 0+	39	RE3P	SECOND CHANNEL 3+
14	RO1N	FIRST CHANNEL 1-	40	Reserved (NC)	No connection(Res for 10Bits)
15	RO1P	FIRST CHANNEL 1+	41	Reserved (NC)	No connection(Res for 10Bits)
16	RO2N	FIRST CHANNEL 2-	42	GND	GND
17	RO2N	FIRST CHANNEL 2+	43	GND	GND
18	GND	Ground	44	GND	Ground
19	ROCLKN	FIRST CLOCK CHANNEL C-	45	GND	Ground
20	ROCLKP	FIRST CLOCK CHANNEL C+	46	GND	Ground
21	GND	Ground	47	NC	NC
22	RO3N	FIRST CHANNEL 3-	48	VLCD	Power Supply +12.0V
23	RO3P	FIRST CHANNEL 3+	49	VLCD	Power Supply +12.0V
24	Reserved (NC)	No connection(Res for 10Bits)	50	VLCD	Power Supply +12.0V
25	Reserved (NC)	No connection(Res for 10Bits)	51	VLCD	Power Supply +12.0V
26	GND	GND	-	-	-

Note :

1. The pin no 44 is LCD Test option.

“AGP” (Auto Generation LCM operates Pattern) or “NSB” (No Signal Black) is case that LVDS signals are out of frequency or abnormal condition in spite of 12 volt power supply.

LPL recommends “NSB”. (AGP : “VCC” or “OPEN” / NSB : “GND”)

2. All GND(ground) pins should be connected together to the LCD module’s metal frame.
3. All VLCD (power input) pins should be connected together.
4. All Input levels of LVDS signals are based on the IEA 664 Standard.
5. Specific pins(pin No. #1~#10) are used for internal data process of the LCD module.

If not used, these pins are no connection.

Product Specification

Table 5. Required signal assignment for Flat Link (Thine : THC63LVD823) Transmitter(Pin7="L")

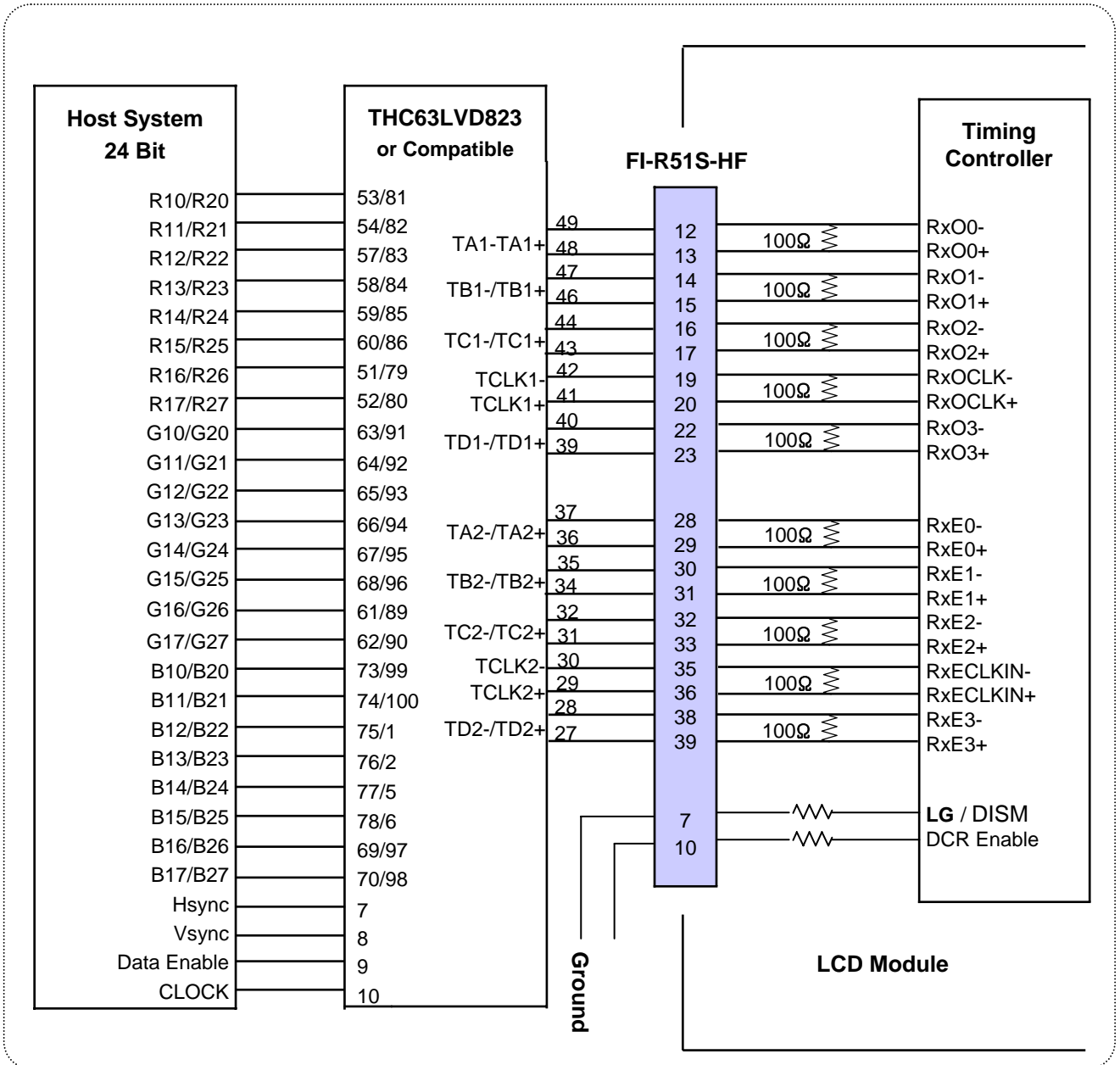

- Note:
1. The LCD module uses a 100 Ohm(Ω) resistor between positive and negative lines of each receiver input.
 2. Refer to LVDS transmitter data sheet for detail descriptions. (THC63LVD823 or Compatible)
 3. '7' means MSB and '0' means LSB at R,G,B pixel data.

Product Specification
3-2-2. Backlight Inverter
www.DataSheet4U.com
Master

- Inverter Connector : S14B-PH-SMC
(manufactured by JST) or Equivalent
- Mating Connector : PHR-14 or Equivalent

Slave

- Inverter Connector : S12B-PH-SMC
(manufactured by JST) or Equivalent
- Mating Connector : PHR-12 or Equivalent

Table 7. INVERTER CONNECTOR PIN CONFIGURATION

Pin No	Symbol	Description	Master	Slave	Note
1	VBL	Power Supply +24.0V	VBL	VBL	
2	VBL	Power Supply +24.0V	VBL	VBL	
3	VBL	Power Supply +24.0V	VBL	VBL	
4	VBL	Power Supply +24.0V	VBL	VBL	
5	VBL	Power Supply +24.0V	VBL	VBL	
6	GND	POWER GND	GND	GND	
7	GND	POWER GND	GND	GND	
8	GND	POWER GND	GND	GND	1
9	GND	POWER GND	GND	GND	
10	GND	POWER GND	GND	GND	
11	Boost	0.0V ~ 3.3V	VBR	Don't care	2
12	VON/OFF	0.0V ~ 5.0V	On/Off	Don't care	3, Open/High for B/L on as default
13	EXTVBR-B	0.0V ~ 3.3V	External PWM	-	4
14	GND	POWER GND	GND	-	5

Note : 1. GND should be connected to the LCD module's metal frame.

2. Minimum Brightness : Boost = 0.0V Maximum Brightness : Boost = 3.3V
 "OPEN" : Boost = 1.65V

3. Rising Edge : Lamp "ON" / Falling Edge : Lamp "OFF"

4. Pin#13 can be opened. (if Pin #13 is open , EXTVBR-B is 100%)

5. Pin#14 can be opened. (Even though Pin #14 is GND or no connection, there is no effect on inverter operating)

6. Each impedance of pin #11, 12 and 13 is 33 [MΩ] , 37 [KΩ] and 596 [KΩ].

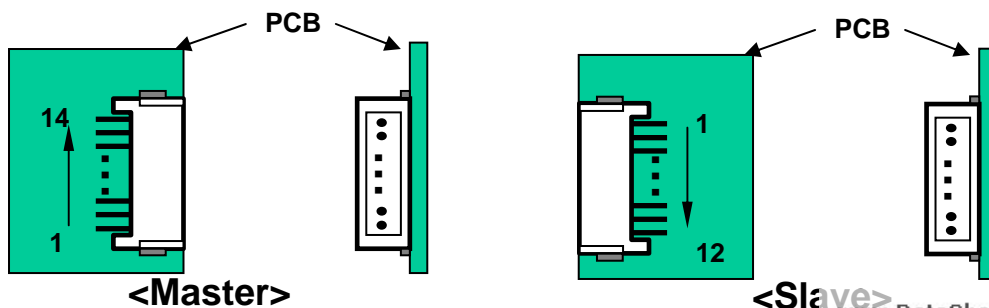
◆ Rear view of LCM

<Master>
<Slave>
www.DataSheet4U.com

Product Specification

3-3. Signal Timing Specifications
www.DataSheet4U.com

Table 8 shows the signal timing required at the input of the LVDS transmitter. All of the interface signal timing should be satisfied with the following specification for normal operation.

Table 8. TIMING TABLE for NTSC & PAL
[DE (Data Enable) Only]

ITEM	Symbol		Min	Typ	Max	Unit	Note
DCLK	Period	tCLK	12.98	13.47	16.77	ns	
	Frequency	-	59.63	74.25	77	MHz	=148.5/2
Hsync	Period	tHP	1060	1100	1300	tCLK	
	Horizontal Valid	tHV	960	960	960	tCLK	
	Horizontal Blank	-	tHP- tHV	140	tHP- tHV		
	Frequency	fH	55.25	67.5	68.9	KHz	
	Width	tWH	-	22	-	tCLK	
	Horizontal Back Porch	tHBP	12	88	-		
	Horizontal Front Porch	tHFP	14	30	-		
Vsync	Period	tVP	1091	1125	1149	tHP	Note 1) PAL : 47~53Hz NTSC : 57~63Hz
	Vertical Valid	tVV	-	1080		tHP	
	Vertical Blank	-	tVP- tVV	45	tVP- tVV	tHP	
	Frequency	fV	47	60	63	Hz	
	Width	tWV	-	12	-	tHP	
	Vertical Back Porch	tVBP	6	25	-	Hz	
	Vertical Front Porch	tVFP	3	8	-	tHP	

Note: 1. The performance of the electro-optical characteristics may be influenced by variance of the vertical refresh rate.

2. Above Timing Tables are only valid for DE Mode.

Product Specification

3-4. Signal Timing Waveforms

www.DataSheet4U.com

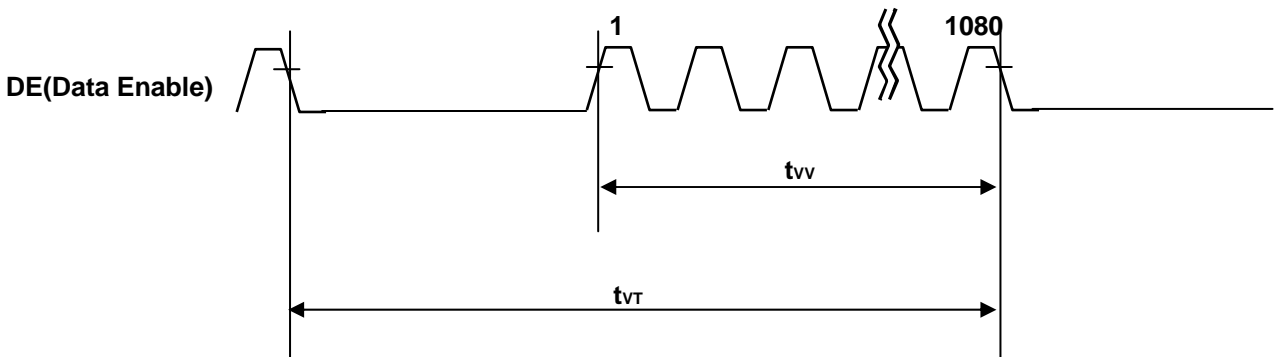
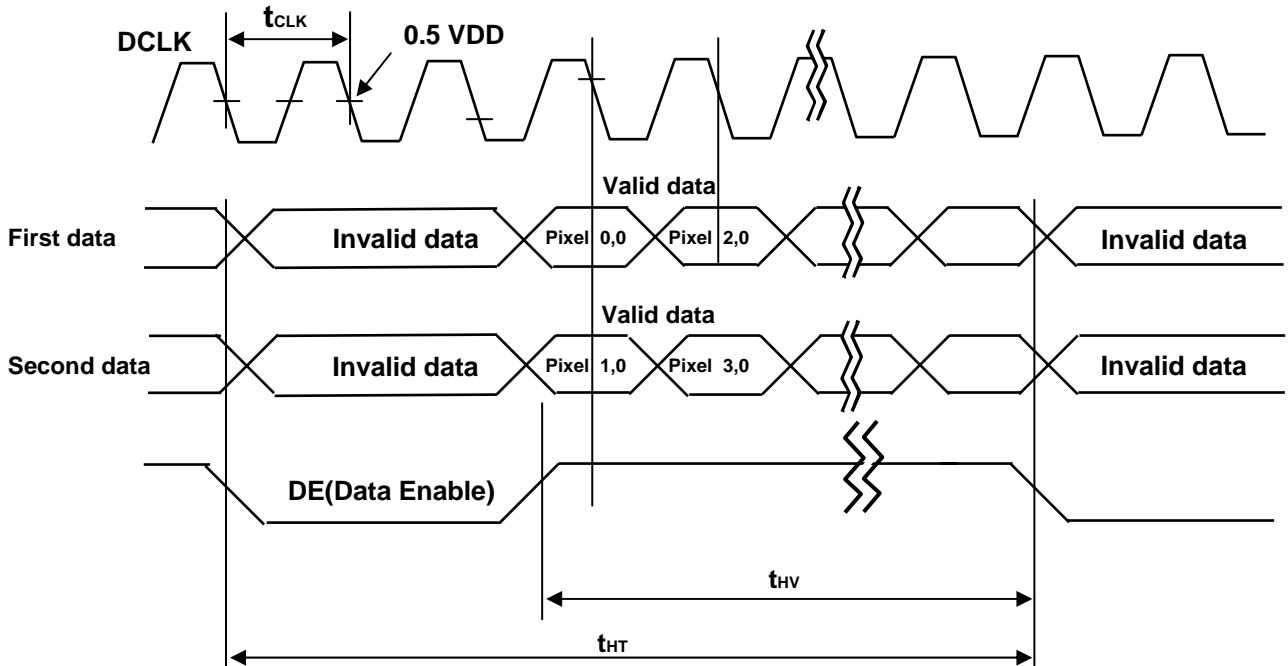
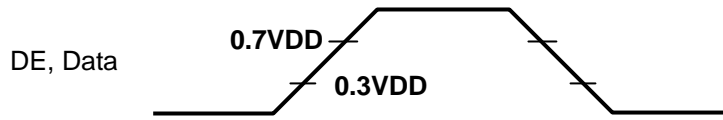

Product Specification
3-5. Color Data Reference
www.DataSheet4U.com

The brightness of each primary color (red, green, blue) is based on the 8-bit gray scale data input for the color. The higher binary input, the brighter the color. Table 9 provides a reference for color versus data input.

Table 9. COLOR DATA REFERENCE

Color		Input Color Data																							
		RED								GREEN								BLUE							
		MSB	LSB						MSB	LSB						MSB	LSB								
		R7	R6	R5	R4	R3	R2	R1	R0	G7	G6	G5	G4	G3	G2	G1	G0	B7	B6	B5	B4	B3	B2	B1	B0
Basic Color	Black	0	0	0	0	0	0	0	0	0	0	0	0	0	0	0	0	0	0	0	0	0	0	0	0
	Red (255)	1	1	1	1	1	1	1	1	0	0	0	0	0	0	0	0	0	0	0	0	0	0	0	0
	Green (255)	0	0	0	0	0	0	0	0	1	1	1	1	1	1	1	1	0	0	0	0	0	0	0	0
	Blue (255)	0	0	0	0	0	0	0	0	0	0	0	0	0	0	0	0	1	1	1	1	1	1	1	1
	Cyan	0	0	0	0	0	0	0	0	1	1	1	1	1	1	1	1	1	1	1	1	1	1	1	1
	Magenta	1	1	1	1	1	1	1	1	0	0	0	0	0	0	0	0	1	1	1	1	1	1	1	1
	Yellow	1	1	1	1	1	1	1	1	1	1	1	1	1	1	1	1	0	0	0	0	0	0	0	0
	White	1	1	1	1	1	1	1	1	1	1	1	1	1	1	1	1	1	1	1	1	1	1	1	1
RED	RED (000) Dark	0	0	0	0	0	0	0	0	0	0	0	0	0	0	0	0	0	0	0	0	0	0	0	0
	RED (001)	0	0	0	0	0	0	0	1	0	0	0	0	0	0	0	0	0	0	0	0	0	0	0	0
							
	RED (254)	1	1	1	1	1	1	1	0	0	0	0	0	0	0	0	0	0	0	0	0	0	0	0	0
	RED (255)	1	1	1	1	1	1	1	1	0	0	0	0	0	0	0	0	0	0	0	0	0	0	0	0
GREEN	GREEN (000) Dark	0	0	0	0	0	0	0	0	0	0	0	0	0	0	0	0	0	0	0	0	0	0	0	0
	GREEN (001)	0	0	0	0	0	0	0	0	0	0	0	0	0	0	0	1	0	0	0	0	0	0	0	0
							
	GREEN (254)	0	0	0	0	0	0	0	0	1	1	1	1	1	1	1	0	0	0	0	0	0	0	0	0
	GREEN (255)	0	0	0	0	0	0	0	0	1	1	1	1	1	1	1	1	0	0	0	0	0	0	0	0
BLUE	BLUE (000) Dark	0	0	0	0	0	0	0	0	0	0	0	0	0	0	0	0	0	0	0	0	0	0	0	0
	BLUE (001)	0	0	0	0	0	0	0	0	0	0	0	0	0	0	0	0	0	0	0	0	0	0	0	1
							
	BLUE (254)	0	0	0	0	0	0	0	0	0	0	0	0	0	0	0	0	1	1	1	1	1	1	1	0
	BLUE (255)	0	0	0	0	0	0	0	0	0	0	0	0	0	0	0	0	1	1	1	1	1	1	1	1

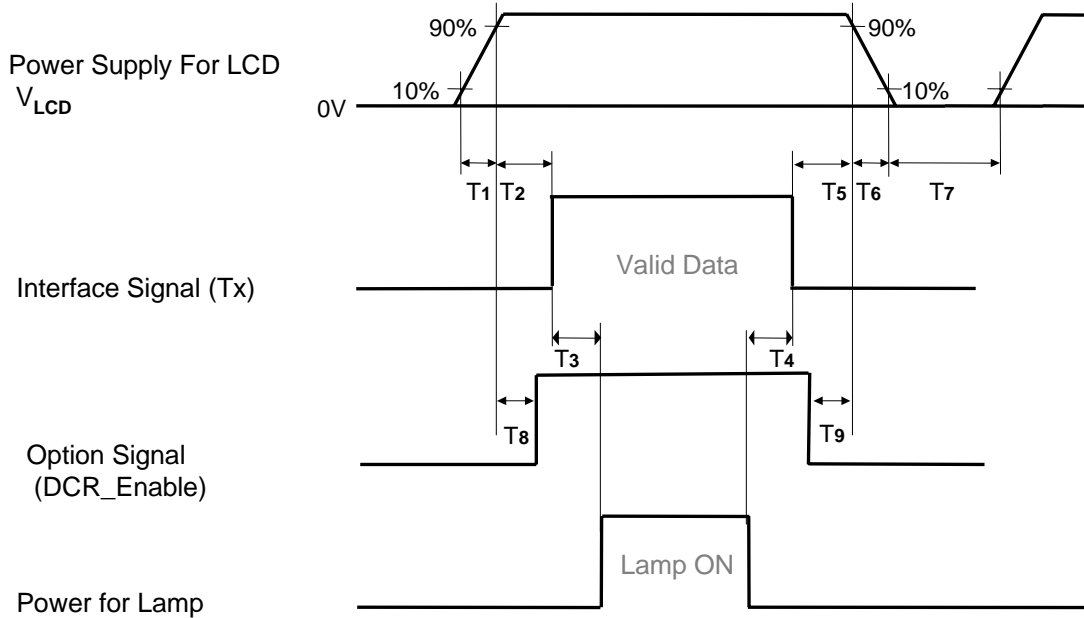
Product Specification
3-6. Power Sequence
www.DataSheet4U.com
3-6-1. LCD Driving circuit

Table 10. POWER SEQUENCE

Parameter	Value			Unit
	Min	Typ	Max	
T1	0.5	-	10	ms
T2	0.5	-	50	ms
T3	200	-	-	ms
T4	200	-	-	ms
T5	0.5	-	50	ms
T6	0.01	-	300	ms
T7	1.0	-	-	s
T8	0 < T8 < T2			ms
T9	0 < T9 < T5			ms

- Note :
1. Please avoid floating state of interface signal at invalid period.
 2. When the interface signal is invalid, be sure to pull down the power supply V_{LCD} to 0V.
 3. The case when the T2/T5 exceed maximum specification, it operates protection pattern(Black pattern) till valid signal inputted. There is no reliability problem.
 4. The T3/T4 is recommended value, the case when failed to meet a minimum specification, abnormal display would be shown. There is no reliability problem.
 5. If the on time of option signal(DISM or AI_Enable) precedes the on time of Power(VLCD), check the LCD logic Power(Vcc) is under 0.8V, otherwise it will be happened abnormal display.
 6. Flicker would come out when power on-off(T7=under 1s) is continuously tested over several ten-times

Product Specification

www.DataSheet4U.com

3-6-2. Sequence for Inverter

Power Supply For Inverter

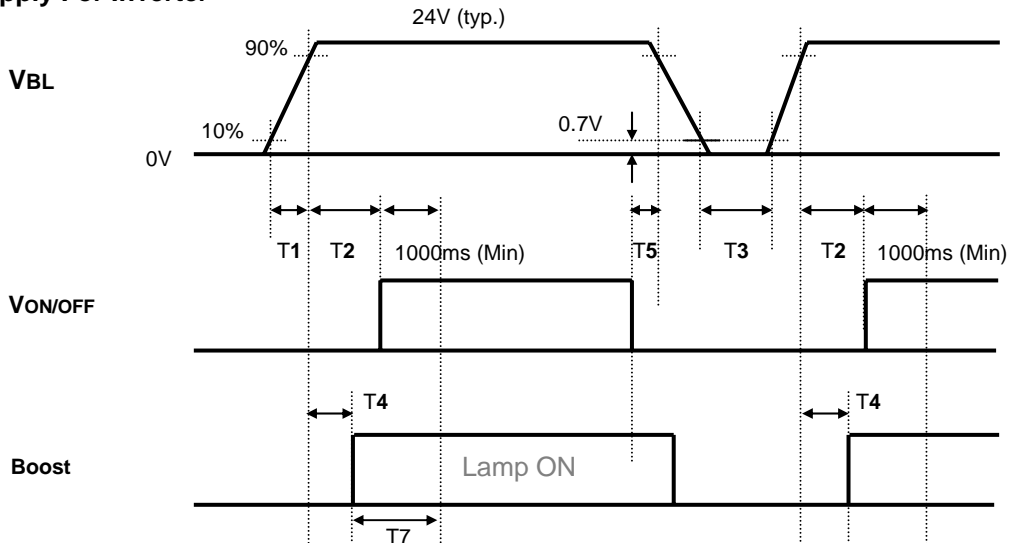

EXTVBR-B : 1. Lamp ON at PWM Rising Edge and Lamp OFF at PWM Falling Edge.
2. EXTVBR-B has Same sequence with **Boost**

3-6-3. Deep condition for Inverter

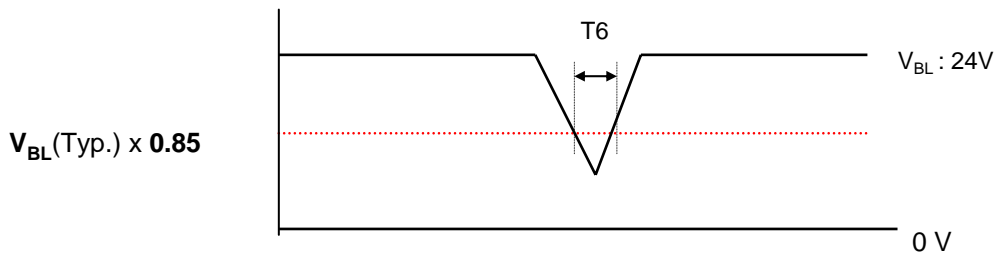

Table 11. Power Sequence for Inverter

Parameter	Values			Units	Remarks
	Min	Typ	Max		
T1	20	-	-	ms	1
T2	500	-	-	ms	
T3	200	-	-	ms	
T4	0	-	-	ms	2
T5	10	-	-	ms	
T6	-	-	10	ms	$V_{BL}(Typ) \times 0.85$
T7	1000	-	-	ms	3

- Notes : 1. T1 describes rising time of 0V to 24V and is not applied at restarting time.
2. T4(max) is less than T2.
3. In T7 section, EXTVBR-B should be duty 100%.
4. When $V_{BL}[24V]$ is supplied always, there is no reliability problem.

www.DataSheet4U.com

Product Specification

4. Optical Specification

www.DataSheet4U.com

Optical characteristics are determined after the unit has been 'ON' and stable for approximately 2 Hrs in a dark environment at $25 \pm 2^\circ\text{C}$. The specified optical values are measured at an approximate 50cm distance from the LCD surface on condition that viewing angle of Φ and θ equal to 0° .

FIG. 1 shows additional information concerning the measurement equipment and method.

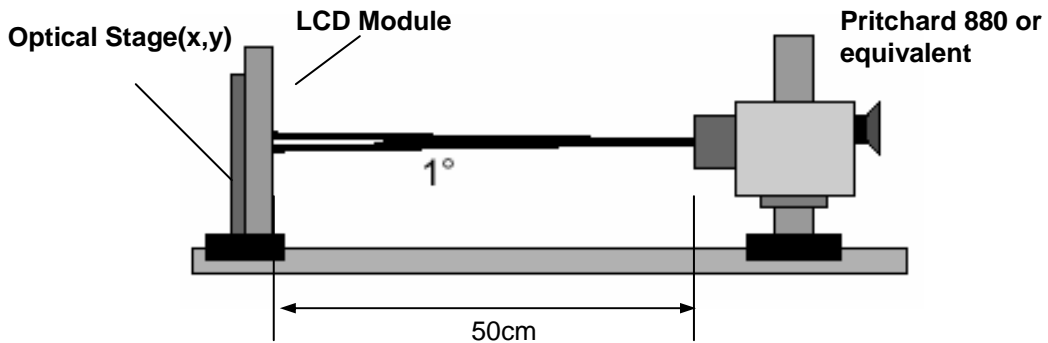

FIG. 1 Optical Characteristic Measurement Equipment and Method

Table 12. OPTICAL CHARACTERISTICS

$T_a = 25 \pm 2^\circ\text{C}$, $V_{LCD} = 12.0\text{V}$, $f_v = 60\text{Hz}$, $D_{clk} = 148.5\text{MHz}$, $VBR = 1.65\text{V}$

Parameter	Symbol	Value			Unit	Note	
		Min	Typ	Max			
Contrast Ratio	CR	600	800	-		1	
Surface Luminance, white	L_{WH}	400	550	-	cd/m^2	2	
Luminance Variation	δ_{WHITE} 5P	-	-	1.6		3	
	δ_{BLACK} 5P	-	-	1.7			
Response Time (Gray-to-Gray)	Gray-to-Gray	G to G	-	8	16	ms	4
	Rise + decay	$T_{R+} + T_{RD}$	-	18	32		
Color Coordinates [CIE1931]	RED	Rx	Typ -0.03	0.638	Typ +0.03		
		Ry		0.340			
	GREEN	Gx		0.279			
		Gy		0.611			
	BLUE	Bx		0.146			
		By		0.062			
	WHITE	Wx		0.285			
	Wy	0.293					
Viewing Angle (CR>10)							
	x axis, right ($\phi=0^\circ$)	θ_r	85	89	-	degree	5
	x axis, left ($\phi=180^\circ$)	θ_l	85	89	-		
	y axis, up ($\phi=90^\circ$)	θ_u	85	89	-		
	y axis, down ($\phi=270^\circ$)	θ_d	85	89	-		
Gray Scale			2.2			6	

Product Specification
Note :

1. Contrast Ratio(CR) is defined mathematically as :

www.DataSheet4U.com

$$\text{Contrast Ratio} = \frac{\text{Surface Luminance with all white pixels}}{\text{Surface Luminance with all black pixels}}$$

Measure Position : Center 1-point

2. Surface Luminance(L_{WH}) is the luminance value measured at an approximate 50cm distance from the center 1-point of LCD surface as all pixels displaying white. See FIG. 2 for more information.
3. The variation of surface luminance , δ WHITE and δ BLACK are defined as :

$$\delta \text{ WHITE}(5P) = \text{Maximum}(L_{on1}, L_{on2}, L_{on3}, L_{on4}, L_{on5}) / \text{Minimum}(L_{on1}, L_{on2}, L_{on3}, L_{on4}, L_{on5})$$

$$\delta \text{ BLACK}(5P) = \text{Maximum}(L_{on1}, L_{on2}, L_{on3}, L_{on4}, L_{on5}) / \text{Minimum}(L_{on1}, L_{on2}, L_{on3}, L_{on4}, L_{on5})$$

Where L_{on1} to L_{on5} are the luminance with all pixels displaying white at 5 locations .
 For more information, see the FIG. 2.

4. Response time is defined as the required time for the transition from G(N) to G(M) (Rise Time, Tr_R) and from G(M) to G(N) (Decay Time, Tr_D). For additional information see the FIG. 3. ($N < M$)
5. Viewing angle is the angle at which the contrast ratio is greater than 10. The angles are determined for the horizontal or x axis and the vertical or y axis with respect to the z axis which is normal to the LCD module surface. For more information, see the FIG. 4.
6. Gray scale specification
 Gamma Value is approximately 2.2. For more information, see the Table 13.

Table 13. GRAY SCALE SPECIFICATION

Gray Level	Luminance [%] (Typ.)
L0	0.19
L15	0.39
L31	1.16
L47	2.61
L63	4.80
L79	7.77
L95	11.6
L111	16.2
L127	21.7
L143	28.2
L159	35.5
L175	43.8
L191	53.0
L207	63.3
L223	74.5
L239	86.7
L255	100

Product Specification

Measuring point for surface luminance & measuring point for luminance variation.

www.DataSheet4U.com

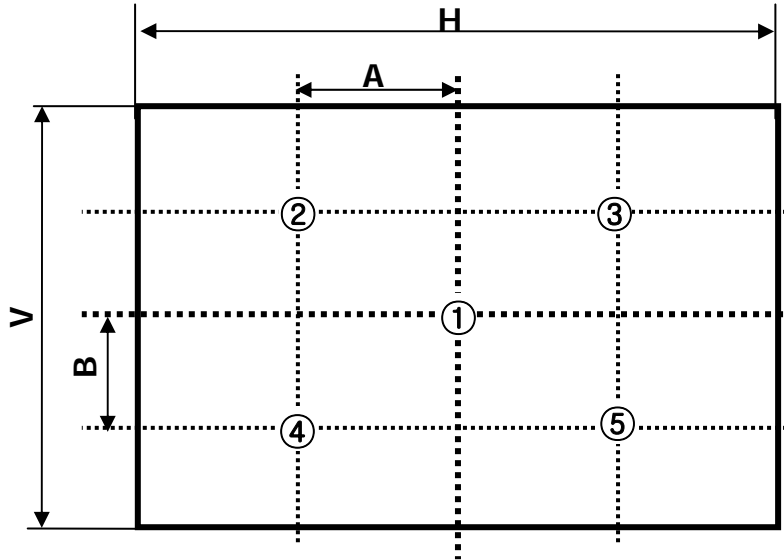

A : $H / 4$ mm
 B : $V / 4$ mm
 H : 930.24 mm
 V : 523.26 mm
 @ H,V : Active Area

FIG. 2 5 Points for Luminance Measure

Response time is defined as the following figure and shall be measured by switching the input signal for "Gray(N)" and "Gray(M)".

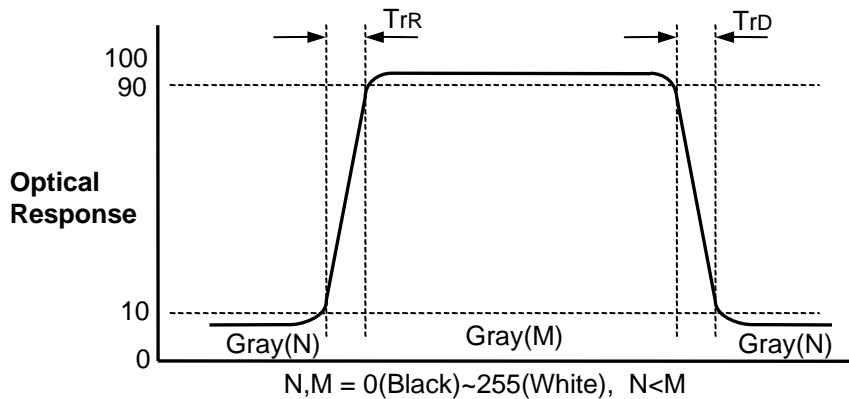

FIG. 3 Response Time

Product Specification

www.DataSheet4U.com

Dimension of viewing angle range

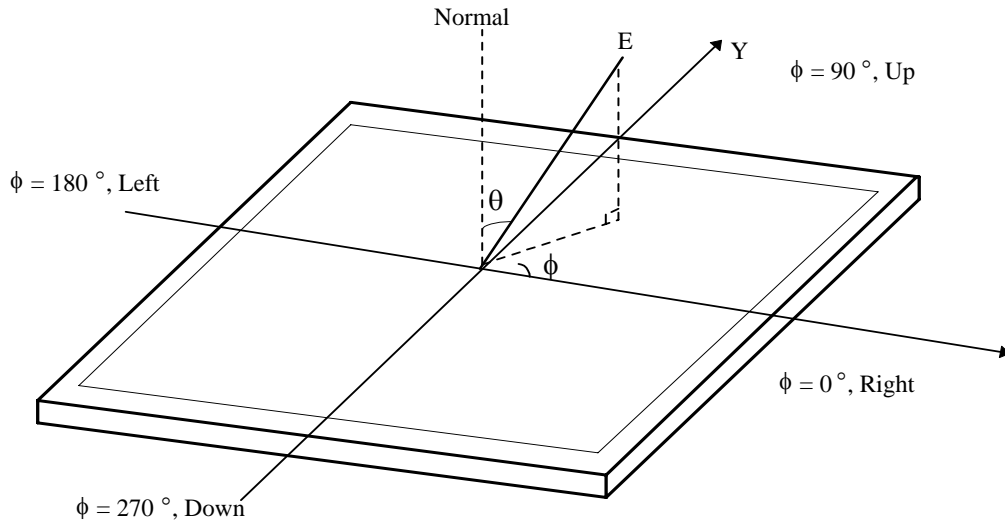

FIG. 4 Viewing Angle

Product Specification

www.DataSheet4U.com

5. Mechanical Characteristics

The contents provide general mechanical characteristics. In addition the figures in the next page are detailed mechanical drawing of the LCD module.

Table 14. MECHANICAL CHARACTERISTICS

Item	Value	
Outline Dimension	Horizontal	983.0 mm
	Vertical	576.0 mm
	Depth	51.0 mm
Bezel Area	Horizontal	939.0 mm
	Vertical	531.0 mm
Active Display Area	Horizontal	930.24 mm
	Vertical	523.26 mm
Weight	13.0Kg (Typ.), 14.0Kg (Max.)	
Surface Treatment	Hard coating(3H) Anti-glare treatment of the front polarizer (Haze 13%)	

Note : 1.Please refer to a mechanic drawing in terms of tolerance at the next page.

Product Specification

www.DataSheet4U.com

<FRONT VIEW>

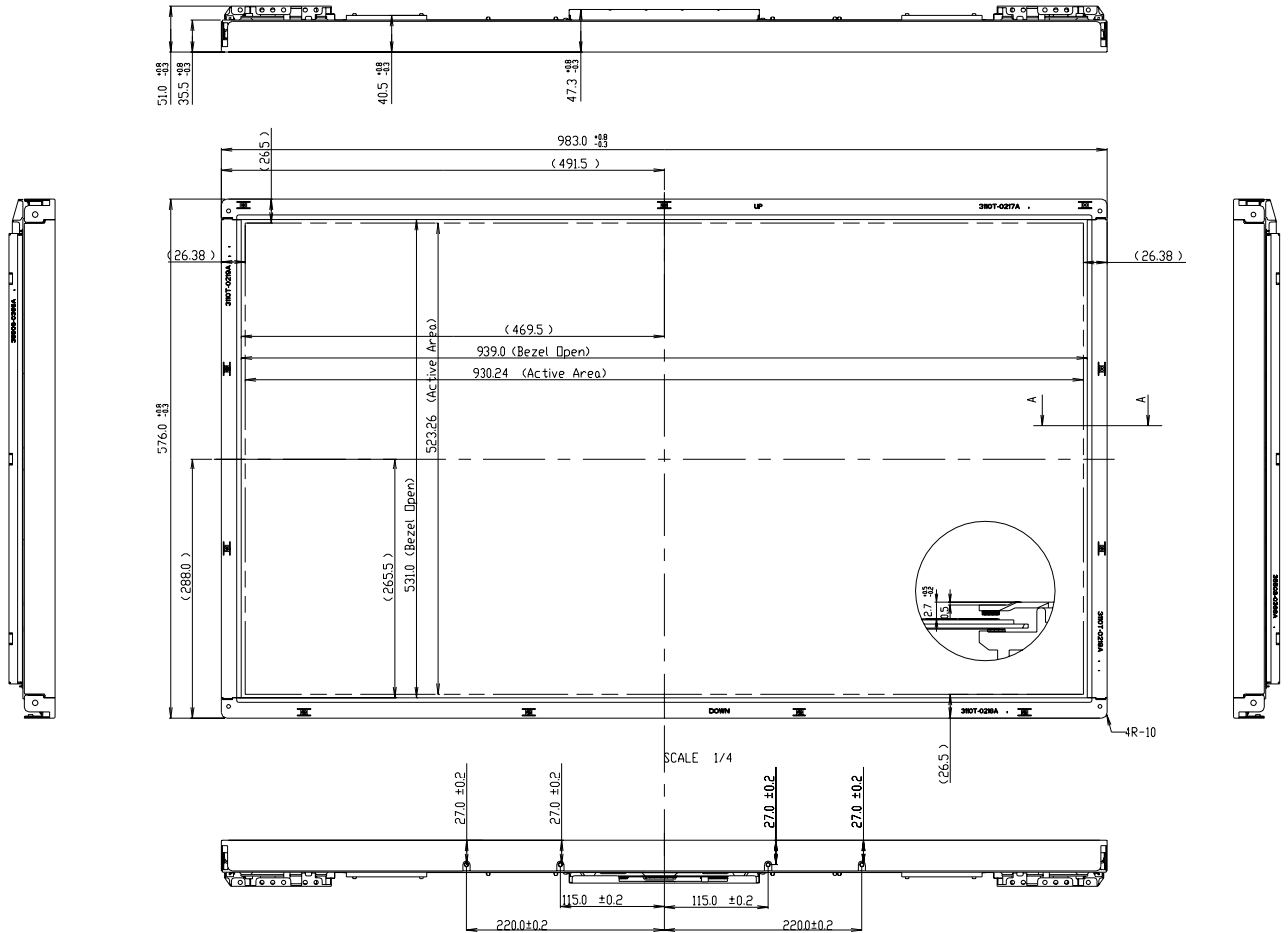

NOTE

1. Unspecified tolerance is $\pm 1.0\text{mm}$
2. Gap between top case pad and pol is $0.7^{+0.05}_{-0.02}$
3. Tilt and partial disposition tolerance of display area as follow
 - 1) Y-direction : $ABS(A-B) \times 1.5$
 - 2) X-direction : $ABS(C-D) \times 1.5$

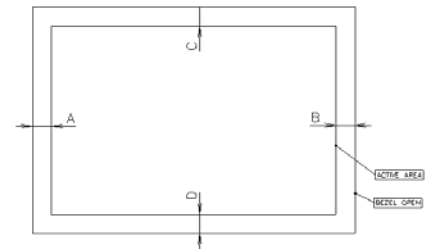

Product Specification

6. Reliability

www.DataSheet4U.com

Table 15. ENVIRONMENT TEST CONDITION

No.	Test Item	Condition
1	High temperature storage test	Ta= 50°C 240h
2	Low temperature storage test	Ta= -20°C 240h
3	High temperature operation test	Ta= 50°C 50%RH 240h
4	Low temperature operation test	Ta= 0°C 240h
5	Vibration test (operating)	Wave form : random Vibration level : 1.0Grms Bandwidth : 10-300Hz Duration : X,Y,Z, 30 min One time each direction
6	Shock test (operating)	Shock level : 50Grms Waveform : half sine wave, 11ms Direction : ±X, ±Y, ±Z One time each direction
7	Humidity condition Operation	Ta= 40 °C ,90%RH
8	Altitude operating storage / shipment	0 - 14,000 feet(4267.2m) 0 - 40,000 feet(12192m)

7. International Standards

7-1. Safety

- a) UL 60065, 7th Edition, dated June 30, 2003, Underwriters Laboratories, Inc., Standard for Audio, Video and Similar Electronic Apparatus.
- b) CAN/CSA C22.2, No. 60065:03, Canadian Standards Association, Standard for Audio, Video and Similar Electronic Apparatus.
- c) IEC60065:2001, 7th Edition CB-scheme and EN 60065:2002, Safety requirements for Audio, Video and Similar Electronic Apparatus..

7-2. EMC

- a) ANSI C63.4 "Methods of Measurement of Radio-Noise Emissions from Low-Voltage Electrical and Electrical Equipment in the Range of 9kHz to 40GHz." American National Standards Institute(ANSI), 1992
- b) CISPR22 "Limits and Methods of Measurement of Radio Interface Characteristics of Information Technology Equipment." International Special Committee on Radio Interference.
- c) EN 55022 "Limits and Methods of Measurement of Radio Interface Characteristics of Information Technology Equipment." European Committee for Electrotechnical Standardization.(CENELEC), 1998 (Including A1: 2000)

Product Specification
www.DataSheet4U.com
8. Packing
8-1. Designation of Lot Mark

a) Lot Mark

A	B	C	D	E	F	G	H	I	J	K	L	M
---	---	---	---	---	---	---	---	---	---	---	---	---

A,B,C : SIZE(INCH)

D : YEAR

F : PANEL CODE

H : ASSEMBLY CODE

E : MONTH

G : FACTORY CODE

I,J,K,L,M : SERIAL NO.

Note

1. YEAR

Year	97	98	99	2000	2001	2002	2003	2004	2005	2006	2007
Mark	7	8	9	0	1	2	3	4	5	6	7

2. MONTH

Month	Jan	Feb	Mar	Apr	May	Jun	Jul	Aug	Sep	Oct	Nov	Dec
Mark	1	2	4	4	5	6	7	8	9	A	B	C

b) Location of Lot Mark

Serial NO. is printed on the label. The label is attached to the backside of the LCD module.
 This is subject to change without prior notice.

8-2. Packing Form

a) Package quantity in one Pallet : 12 pcs

b) Pallet Size : 1150 mm X 1000 mm X 820 mm.

Product Specification

www.DataSheet4U.com

9. Precautions

Please pay attention to the followings when you use this TFT LCD module.

9-1. Mounting Precautions

- (1) You must mount a module using holes arranged in four corners or four sides.
- (2) You should consider the mounting structure so that uneven force (ex. Twisted stress) is not applied to the module. And the case on which a module is mounted should have sufficient strength so that external force is not transmitted directly to the module.
- (3) Please attach the surface transparent protective plate to the surface in order to protect the polarizer. Transparent protective plate should have sufficient strength in order to resist external force.
- (4) You should adopt radiation structure to satisfy the temperature specification.
- (5) Acetic acid type and chlorine type materials for the cover case are not desirable because the former generates corrosive gas of attacking the polarizer at high temperature and the latter causes circuit break by electro-chemical reaction.
- (6) Do not touch, push or rub the exposed polarizers with glass, tweezers or anything harder than HB pencil lead. And please do not rub with dust clothes with chemical treatment. Do not touch the surface of polarizer for bare hand or greasy cloth.(Some cosmetics are detrimental to the polarizer.)
- (7) When the surface becomes dusty, please wipe gently with absorbent cotton or other soft materials like chamois soaks with petroleum benzene. Normal-hexane is recommended for cleaning the adhesives used to attach front / rear polarizers. Do not use acetone, toluene and alcohol because they cause chemical damage to the polarizer.
- (8) Wipe off saliva or water drops as soon as possible. Their long time contact with polarizer causes deformations and color fading.
- (9) Do not open the case because inside circuits do not have sufficient strength.

9-2. Operating Precautions

- (1) The spike noise causes the mis-operation of circuits. It should be lower than following voltage :
 $V = \pm 200\text{mV}$ (Over and under shoot voltage)
- (2) Response time depends on the temperature.(In lower temperature, it becomes longer.)
- (3) Brightness depends on the temperature. (In lower temperature, it becomes lower.)
And in lower temperature, response time(required time that brightness is stable after turned on) becomes longer.
- (4) Be careful for condensation at sudden temperature change. Condensation makes damage to polarizer or electrical contacted parts. And after fading condensation, smear or spot will occur.
- (5) When fixed patterns are displayed for a long time, remnant image is likely to occur.
- (6) Module has high frequency circuits. Sufficient suppression to the electromagnetic interference shall be done by system manufacturers. Grounding and shielding methods may be important to minimized the interference.
- (7) Please do not give any mechanical and/or acoustical impact to LCM. Otherwise, LCM can't be operated its full characteristics perfectly.
- (8) A screw which is fastened up the steels should be a machine screw.
(if not, it causes metallic foreign material and deal LCM a fatal blow)
- (9) Please do not set LCD on its edge.

Product Specification

www.DataSheet4U.com**9-3. Electrostatic Discharge Control**

Since a module is composed of electronic circuits, it is not strong to electrostatic discharge. Make certain that treatment persons are connected to ground through wrist band etc. And don't touch interface pin directly.

9-4. Precautions for Strong Light Exposure

Strong light exposure causes degradation of polarizer and color filter.

9-5. Storage

When storing modules as spares for a long time, the following precautions are necessary.

- (1) Store them in a dark place. Do not expose the module to sunlight or fluorescent light. Keep the temperature between 5°C and 35°C at normal humidity.
- (2) The polarizer surface should not come in contact with any other object.
It is recommended that they be stored in the container in which they were shipped.

9-6. Handling Precautions for Protection Film

- (1) The protection film is attached to the bezel with a small masking tape.
When the protection film is peeled off, static electricity is generated between the film and polarizer.
This should be peeled off slowly and carefully by people who are electrically grounded and with well ion-blown equipment or in such a condition, etc.
- (2) When the module with protection film attached is stored for a long time, sometimes there remains a very small amount of glue still on the bezel after the protection film is peeled off.
- (3) You can remove the glue easily. When the glue remains on the bezel surface or its vestige is recognized, please wipe them off with absorbent cotton waste or other soft material like chamois soaked with normal-hexane.