

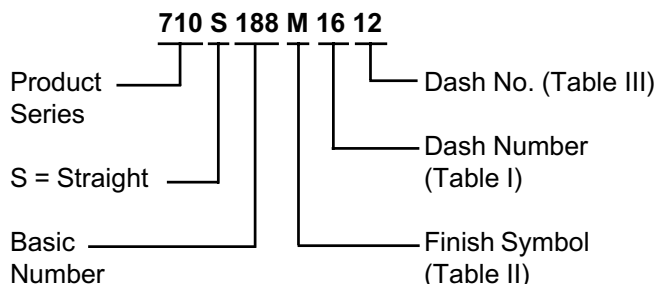

710-188 Non-Environmental User-Installable Transition Fitting for Series 72 Annular Convulsed Tubing

TYPE A



**TO BE USED WITH ADAPTERS
AND TRANSITIONS SHOWN ON
PAGES G-1 THROUGH G-19**

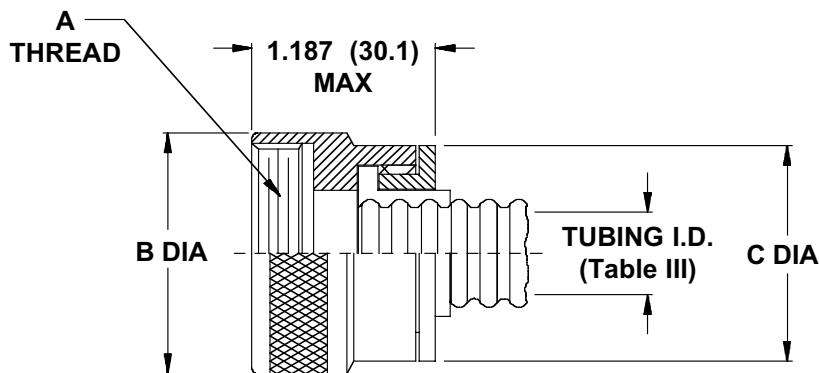

TABLE I		
DASH NO.	A THREAD CLASS 2B	B DIA MAX
09	9/16 - 24 UNEF	.717 (18.2)
12	5/8 - 24 UNEF	.780 (19.8)
16	3/4 - 20 UNEF	.905 (23.0)
20	7/8 - 20 UNEF	1.030 (26.2)
24	1 - 20 UNEF	1.155 (29.3)
28	1 3/16 - 18 UNEF	1.342 (34.1)
32	1 5/16 - 18 UNEF	1.467 (37.3)
40	1 1/2 - 18 UNEF	1.655 (42.0)

TABLE II	
SYMBOL	FINISH
B	Olive Drab over Cadmium Plate
J	Gold Iridite over Cadmium Plate over Nickel
M	Electroless Nickel
N	Olive Drab over Cadmium Plate over Nickel
NF	Olive Drab over Cadmium Plate over Electroless Nickel (500 Hour Salt Spray)
T	Bright Dip Cadmium Plate over Nickel
NC	Zinc-Cobalt, Olive Drab

TABLE III			
DASH NO.	C DIA MAX	TUBING I.D.	
		MIN	MAX
09	.875 (22.2)	.24 (6.1)	.28 (7.1)
12	1.020 (25.9)	.33 (8.4)	.37 (9.4)
16	1.135 (28.8)	.45 (11.4)	.50 (12.7)
20	1.270 (32.3)	.57 (14.5)	.62 (15.7)
24	1.458 (37.0)	.69 (17.5)	.75 (19.1)
28	1.645 (41.8)	.81 (20.6)	.87 (22.1)
32	1.770 (45.0)	.93 (23.6)	1.00 (25.4)
40	2.020 (51.3)	1.18 (30.0)	1.25 (31.8)

Metric dimensions (mm) are in parentheses.
Tubing shown for reference only.