



SANYO Semiconductors

DATA SHEET

LC877C64C, LC877C56C
LC877C48C, LC877C40C
LC877C32C, LC877C24C

CMOS IC
 Internal 64K/56K/48K/40K/32K/24K-byte ROM
 and 2048/1536-byte RAM

8-bit 1-chip Microcontroller

Overview

The LC877C00 series are an 8-bit single chip microcontroller with the following on-chip functional blocks. :

- CPU: operable at a minimum bus cycle time of 83.3ns
- On-chip 64K-24K bytes ROM
- On-chip RAM: 2048/1536 bytes
- LCD controller / driver
- 16 bit timer/counters (can be divided into 8-bit units)
- 16 bit timer / PWM (can be divided into two 8-bit timers)
- Four 8-bit timer with prescalers
- Timer for use as date / time clock
- Synchronous serial I/O port (with automatic block transmit / receive function)
- Asynchronous / synchronous serial I/O port
- 2 channel 12bit PWM
- 12-channel × 8-bit AD converter
- High-speed clock counter
- System clock divider
- Small signal detector
- 20 source 10-vectored interrupt system

All of the above functions are fabricated on a single chip.

Features

■ROM

- 65536 × 8 bits (LC877C64C)
- 57344 × 8 bits (LC877C56C)
- 49152 × 8 bits (LC877C48C)
- 40960 × 8 bits (LC877C40C)
- 32768 × 8 bits (LC877C32C)
- 24576 × 8 bits (LC877C24C)

■ Any and all SANYO Semiconductor products described or contained herein do not have specifications that can handle applications that require extremely high levels of reliability, such as life-support systems, aircraft's control systems, or other applications whose failure can be reasonably expected to result in serious physical and/or material damage. Consult with your SANYO Semiconductor representative nearest you before using any SANYO Semiconductor products described or contained herein in such applications.

■ SANYO Semiconductor assumes no responsibility for equipment failures that result from using products at values that exceed, even momentarily, rated values (such as maximum ratings, operating condition ranges, or other parameters) listed in products specifications of any and all SANYO Semiconductor products described or contained herein.

SANYO Semiconductor Co., Ltd.

TOKYO OFFICE Tokyo Bldg., 1-10, 1 Chome, Ueno, Taito-ku, TOKYO, 110-8534 JAPAN

LC877C64C/56C/48C/40C/32C/24C

■RAM

- 2048 × 9 bits (LC877C64C/56C)
- 1536 × 9 bits (LC877C48C/40C/32C/24C)

■Minimum Instruction Cycle Time

- 250 ns (12MHz) $V_{DD}=4.5$ to 5.5V
- 300 ns (10MHz) $V_{DD}=2.8$ to 5.5V
- 750 ns (4MHz) $V_{DD}=2.2$ to 5.5V

■Ports

- Input/output ports
 - Data direction programmable for each bit individually: 20 (P1n, P70 to P73, P8n)
 - Data direction programmable in nibble units: 8 (P0n)
(When N-channel open drain output is selected, data can be input in bit units.)
- Input ports: 2 (XT1, XT2)
- Output ports: 2 (PWM2, PWM3)
- LCD ports
 - Segment output: 32 (S00 to S15, S24 to S39)
 - Common output: 4 (COM0 to COM3)
 - Bias terminals for LCD driver: 3 (V1 to V3)
- Other functions
 - Input/output ports: 32 (PAn, PBn, PDn, PEn)
 - Input ports: 7 (PLn)
- Oscillator pins: 2 (CF1, CF2)
- Reset pin: 1 (RES)
- Power supply: 6 (V_{SS1-3} , V_{DD1-3})

■LCD Controller

- Seven display modes are available (static, 1/2, 1/3, 1/4 duty × 1/2, 1/3 bias)
- Segment output and common output can be switched to general purpose input/output ports.

■Small Signal Detection (MIC signals etc)

- Counts pulses with the level which is greater than a preset value
- 2 bit counter

■Timers

- Timer 0: 16 bit timer / counter with capture register
 - Mode 0: 2 channel 8-bit timer with programmable 8 bit prescaler and 8 bit capture register
 - Mode 1: 8 bit timer with 8 bit programmable prescaler and 8 bit capture register
+ 8 bit Counter with 8-bit capture register
 - Mode 2: 16 bit timer with 8 bit programmable prescaler and 16 bit capture register
 - Mode 3: 16 bit counter with 16 bit capture register
- Timer 1: PWM / 16 bit timer/ counter with toggle output function
 - Mode 0: 8-bit timer with 8-bit prescaler (and toggle output) + 8-bit timer / counter with 8-bit prescaler
(and toggle output)
 - Mode 1: 2 channel 8-bit PWM with 8-bit prescaler
 - Mode 2: 16-bit timer / counter with 8-bit prescaler (and toggle output)
(Toggle output also possible using the lower order 8 bits)
 - Mode 3: 16-bit timer with 8-bit prescaler (and toggle output)
(The lower order 8 bits can be used as PWM output)
- Timer 4: 8-bit timer with 6-bit prescaler
- Timer 5: 8-bit timer with 6-bit prescaler
- Timer 6: 8-bit timer with 6-bit prescaler (and toggle output)
- Timer 7: 8-bit timer with 6-bit prescaler (and toggle output)
- Base Timer
 - 1) The clock signal can be selected from any of the following :
Sub-clock (32.768kHz crystal oscillator), system clock, and prescaler output from timer 0
 - 2) Interrupts of five different time intervals are possible.

LC877C64C/56C/48C/40C/32C/24C

■ High-speed Clock Counter

- Countable up to 20MHz clock (when using 10MHz main clock)
- Real time output

■ SIO

- SIO 0: 8 bit synchronous serial interface
 - 1) LSB first / MSB first is selectable
 - 2) Internal 8 bit baud-rate generator (fastest clock period 4 / 3 tCYC)
 - 3) Consecutive automatic data communication (1 to 256 bits)
- SIO 1: 8 bit asynchronous / synchronous serial interface
 - Mode 0: Synchronous 8 bit serial IO (2-wire or 3-wire, transmit clock 2 to 512 tCYC)
 - Mode 1: Asynchronous serial IO (half duplex, 8 data bits, 1 stop bit, baud rate 8 to 2048 tCYC)
 - Mode 2: Bus mode 1 (start bit, 8 data bits, transmit clock 2 to 512 tCYC)
 - Mode 3: Bus mode 2 (start detection, 8 data bits, stop detection)

■ AD Converter: 8 bits × 12 channels

■ PWM: 2 Channels Multi-frequency 12-bit PWM

■ Remote Control Receiver Circuit (connected to P73 / INT3 / T0IN terminal)

- Noise rejection function (noise rejection filter's time constant can be selected from 1 / 32 / 128 tCYC)

■ Watchdog Timer

- The watching time period is determined by an external RC.
- Watchdog timer can produce interrupt or system reset

■ Interrupts: 20 sources, 10 vectors

- 1) Three priority (low, high and highest) multiple interrupts are supported. During interrupt handling, an equal or lower priority interrupt request is postponed.
- 2) If interrupt requests to two or more vector addresses occur at once, the higher priority interrupt takes precedence. In the case of equal priority levels, the vector with the lowest address takes precedence.

No.	Vector Address	Level	Interrupt Source
1	00003H	X or L	INT0
2	0000BH	X or L	INT1
3	00013H	H or L	INT2/T0L
4	0001BH	H or L	INT3/Base timer0 /Base timer1
5	00023H	H or L	T0H
6	0002BH	H or L	T1L/T1H
7	00033H	H or L	SIO0
8	0003BH	H or L	SIO1
9	00043H	H or L	ADC/MIC/T6/T7
10	0004BH	H or L	Port 0/T4/T5/PWM2, PWM3

- Priority level: X > H > L
- For equal priority levels, vector with lowest address takes precedence.

■ Subroutine Stack Levels: 1024 levels max (LC877C64C/56C)

768 levels max (LC877C48C/40C/32C/24C)

Stack is located in RAM.

■High-speed Multiplication/Division Instructions

- 16 bits × 8 bits (5 tCYC execution time)
- 24 bits × 16 bits (12 tCYC execution time)
- 16 bits ÷ 8 bits (8 tCYC execution time)
- 24 bits ÷ 16 bits (12 tCYC execution time)

■Oscillation Circuits

- On-chip RC oscillation for system clock use.
- CF oscillation for system clock use. (Rf built in, Rd external)
- Crystal oscillation low speed system clock use. (Rf built in, Rd external)
- On-chip frequency variable RC oscillation circuit for system clock use.

■System Clock Divider

- Low power consumption operation is available
- Minimum instruction cycle time (300ns, 600ns, 1.2μs, 2.4μs, 4.8μs, 9.6μs, 19.2μs, 38.4μs, 76.8μs can be switched by program (when using 10MHz main clock)

■Standby Function

• HALT mode

HALT mode is used to reduce power consumption. During the HALT mode, program execution is stopped but peripheral circuits keep operating (some parts of serial transfer operation stop).

- 1) Oscillation circuits are not stopped automatically.
- 2) Released by the system reset or interrupts.

• HOLD mode

HOLD mode is used to reduce power consumption. Program execution and peripheral circuits are stopped.

- 1) CF, RC, X'tal and multi-frequency RC oscillation circuits stop automatically.
- 2) Released by any of the following conditions.
 - (1) Low level input to the reset pin
 - (2) Specified level input to one of INT0, INT1, INT2
 - (3) Port 0 interrupt

• X'tal HOLD mode

X'tal HOLD mode is used to reduce power consumption. Program execution is stopped.

All peripheral circuits except the base timer are stopped.

- 1) CF, RC and multi-frequency RC oscillation circuits stop automatically.
- 2) Crystal oscillator operation is kept in its state at HOLD mode inception.
- 3) Released by any of the following conditions
 - (1) Low level input to the reset pin
 - (2) Specified level input to one of INT0, INT1, INT2
 - (3) Port 0 interrupt
 - (4) Base-timer interrupt

■Package Form

- QFP80 (14 × 14): Lead-free type
- TQFP80J (12 × 12): Lead-free type

■Development Tools

- Evaluation chip: LC87EV690
- Emulator: EVA62S + ECB876600D + SUB877100 + POD80QFP(14 × 14) or POD80SQFP
ICE-B877300 + SUB877100 + POD80QFP(14 × 14) or POD80SQFP
- Flash ROM Version: LC87F7CC8A

LC877C64C/56C/48C/40C/32C/24C

Package Dimensions

unit : mm (typ)
3255

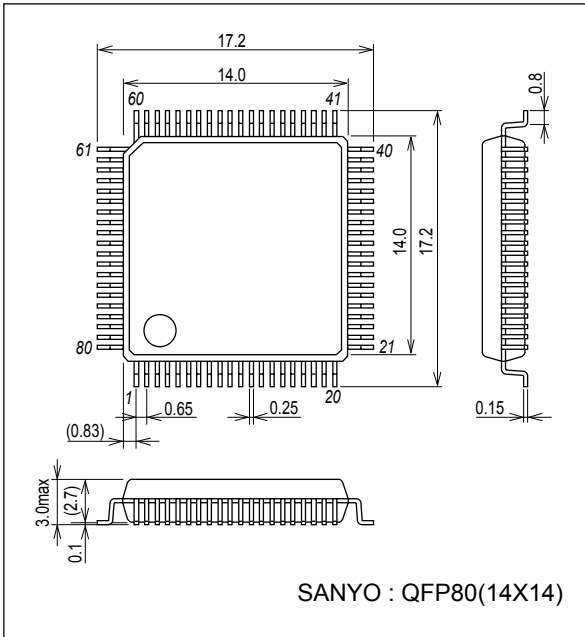

Package Dimensions

unit : mm (typ)
3290

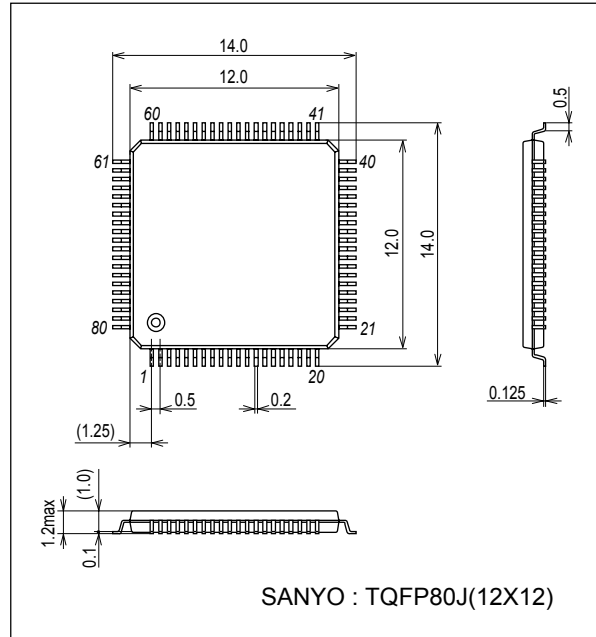

Pin Assignment

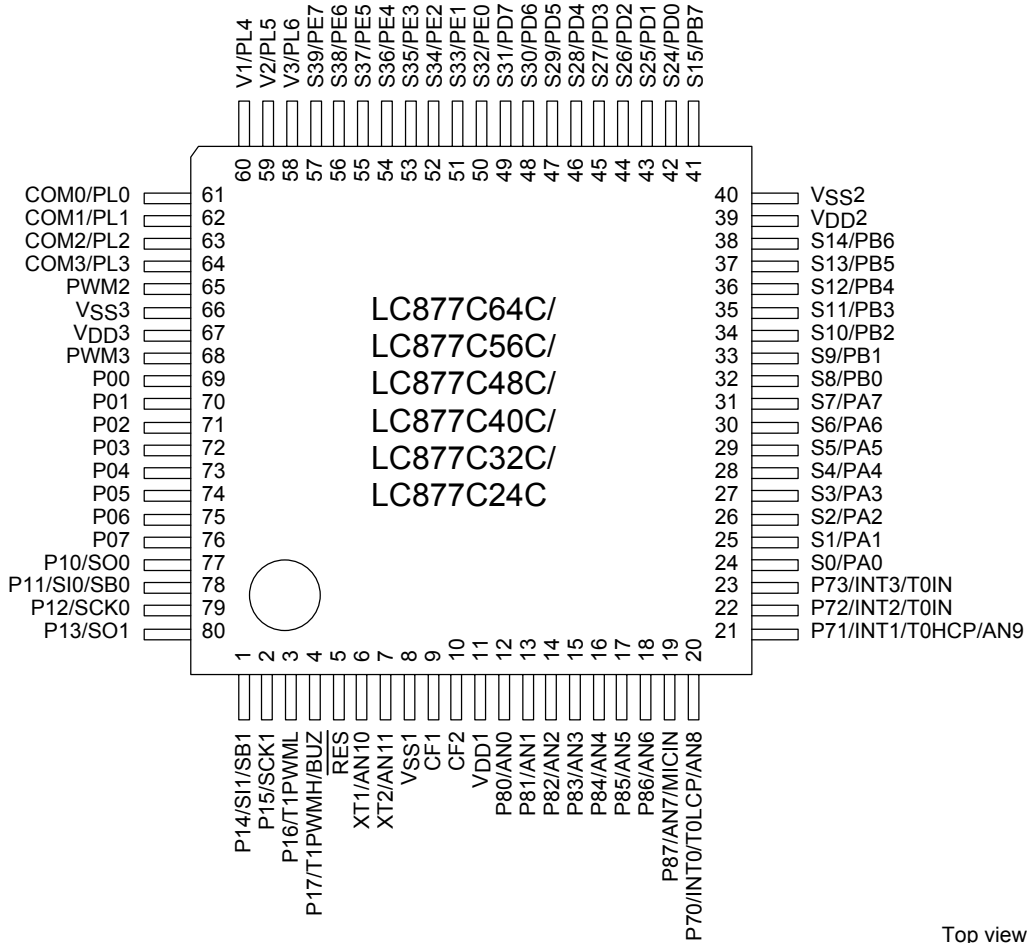

SANYO : QFP80 (14 × 14)

SANYO : TQFP80J (12 × 12)

“Lead-free Type”

“Lead-free Type”

System Block Diagram

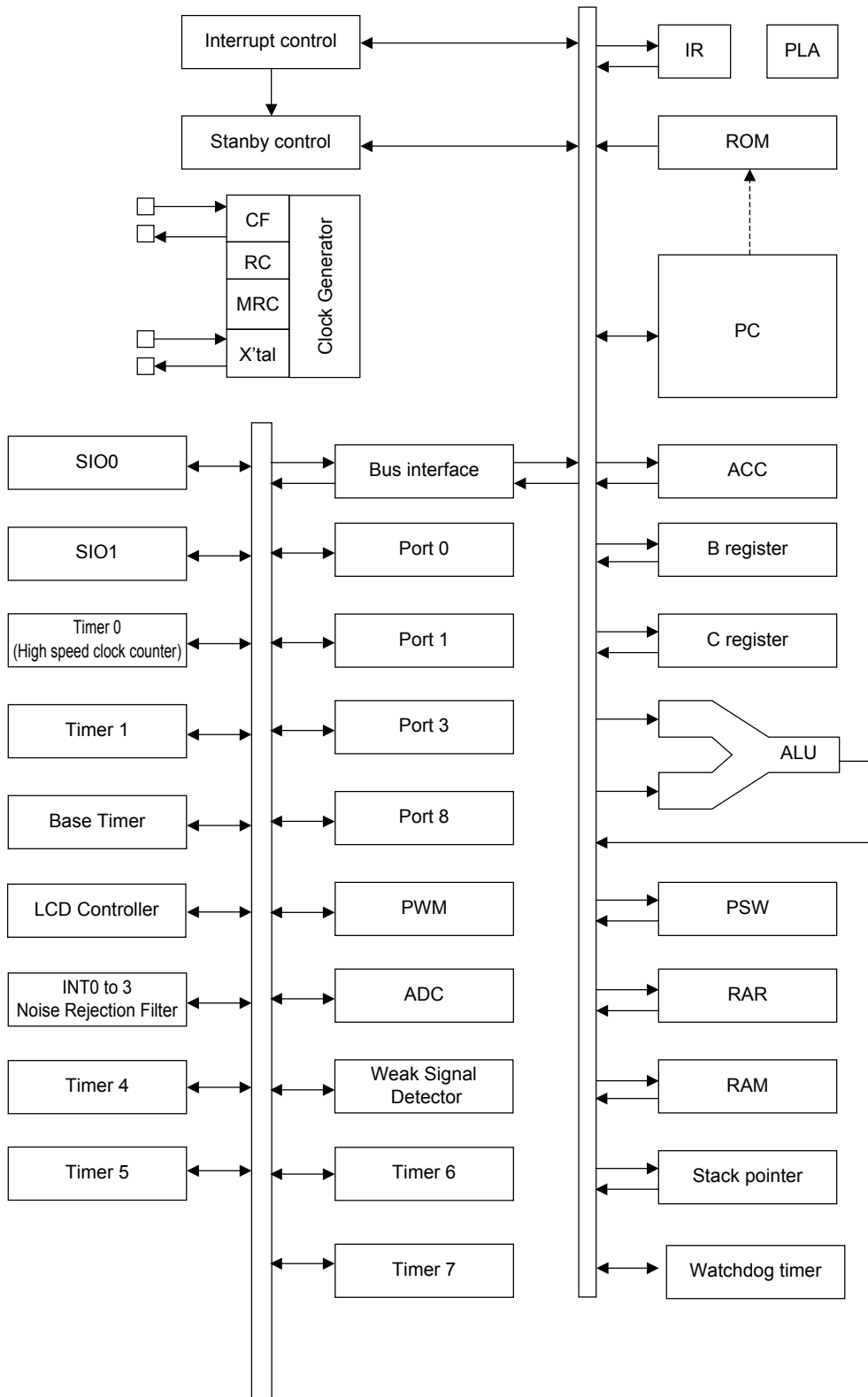

LC877C64C/56C/48C/40C/32C/24C

Pin Description

Pin name	I/O	Function	Option																														
V _{SS} 1, V _{SS} 2, V _{SS} 3	-	• Power supply (-)	No																														
V _{DD} 1, V _{DD} 2, V _{DD} 3	-	• Power supply (+)	No																														
PORT0 P00 to P07	I/O	<ul style="list-style-type: none"> • 8bit input/output port • Data direction programmable in nibble units • Use of pull-up resistor can be specified in nibble units • Input for HOLD release • Input for port 0 interrupt • Other functions P05: clock output (system clock / can selected from sub clock) P06: timer 6 toggle output P07: timer 7 toggle output	Yes																														
PORT1 P10 to P17	I/O	<ul style="list-style-type: none"> • 8bit input/output port • Data direction programmable for each bit • Use of pull-up resistor can be specified for each bit individually • Other pin functions P10 SIO0 data output P11 SIO0 data input or bus input/output P12 SIO0 clock input/output P13 SIO1 data output P14 SIO1 data input or bus input/output P15 SIO1 clock input/output P16: Timer 1 PWML output P17: Timer 1 PWMH output/Buzzer output	Yes																														
PORT7 P70 to P73	I/O	<ul style="list-style-type: none"> • 4bit Input/output port • Data direction can be specified for each bit • Use of pull-up resistor can be specified for each bit individually • Other functions P70: INT0 input/HOLD release input/Timer0L capture input/output for watchdog timer P71: INT1 input/HOLD release input/Timer0H capture input P72: INT2 input/HOLD release input/timer 0 event input/Timer0L capture input P73: INT3 input(noise rejection filter attached)/timer 0 event input/Timer0H capture input AD input port: AN8(P70), AN9(P71)	No																														
		<ul style="list-style-type: none"> • Interrupt detection selection <table border="1" style="margin-left: 20px;"> <thead> <tr> <th></th> <th>Rising</th> <th>Falling</th> <th>Rising and falling</th> <th>H level</th> <th>L level</th> </tr> </thead> <tbody> <tr> <td>INT0</td> <td>enable</td> <td>enable</td> <td>disable</td> <td>enable</td> <td>enable</td> </tr> <tr> <td>INT1</td> <td>enable</td> <td>enable</td> <td>disable</td> <td>enable</td> <td>enable</td> </tr> <tr> <td>INT2</td> <td>enable</td> <td>enable</td> <td>enable</td> <td>disable</td> <td>disable</td> </tr> <tr> <td>INT3</td> <td>enable</td> <td>enable</td> <td>enable</td> <td>disable</td> <td>disable</td> </tr> </tbody> </table>		Rising	Falling	Rising and falling	H level	L level	INT0	enable	enable	disable	enable	enable	INT1	enable	enable	disable	enable	enable	INT2	enable	enable	enable	disable	disable	INT3	enable	enable	enable	disable	disable	
	Rising	Falling	Rising and falling	H level	L level																												
INT0	enable	enable	disable	enable	enable																												
INT1	enable	enable	disable	enable	enable																												
INT2	enable	enable	enable	disable	disable																												
INT3	enable	enable	enable	disable	disable																												

Continued on next page.

LC877C64C/56C/48C/40C/32C/24C

Continued from preceding page.

Pin name	I/O	Function description	Option
PORT8 P80 to P87	I/O	<ul style="list-style-type: none"> • 8bit Input/output port • Input/output can be specified for each bit individually • Other functions: AD input port: AN0 to AN7 Small signal detector input port: MICIN(P87) 	No
S0/PA0 to S7/PA7	I/O	<ul style="list-style-type: none"> • Segment output for LCD • Can be used as general purpose input/output port (PA) 	No
S8/PB0 to S15/PB7	I/O	<ul style="list-style-type: none"> • Segment output for LCD • Can be used as general purpose input/output port (PB) 	No
S24 /PD0 to S31/PD7	I/O	<ul style="list-style-type: none"> • Segment output for LCD • Can be used as general purpose input/output port (PD) 	No
S32/PE0 to S39/PE7	I/O	<ul style="list-style-type: none"> • Segment output for LCD • Can be used as general purpose input/output port (PE) 	No
COM0/PL0 to COM3/PL3	I/O	<ul style="list-style-type: none"> • Common output for LCD • Can be used as general purpose input port (PL) 	No
V1/PL4 to V3/PL6	I/O	<ul style="list-style-type: none"> • LCD output bias power supply • Can be used as general purpose input port (PL) 	No
PWM2	O	PWM2 output port	No
PWM3	O	PWM3 output port	No
$\overline{\text{RES}}$	I	Reset terminal	No
XT1	I	<ul style="list-style-type: none"> • Input for 32.768kHz crystal oscillation • Other functions: General-purpose input port AD input port: AN10 • When not in use, connect to V_{DD1} 	No
XT2	I/O	<ul style="list-style-type: none"> • Output for 32.768kHz crystal oscillation • Other functions: General purpose input port AD input port: AN11 • When not in use, set to oscillation mode and leave open 	No
CF1	I	Input terminal for ceramic oscillator	No
CF2	O	Output terminal for ceramic oscillator	No

Port Output Types

Port form and pull-up resistor options are shown in the following table.

Port status can be read even when port is set to output mode.

Port Name	Option Selected in Units of	Option Type	Output Type	Pull-up Resistor
P00 to P07	each bit	1	CMOS	Programmable (Note 1)
		2	Nch-open drain	None
P10 to P17	each bit	1	CMOS	Programmable
		2	Nch-open drain	Programmable
P70	-	None	Nch-open drain	Programmable
P71 to P73	-	None	CMOS	Programmable
P80 to P87	-	None	Nch-open drain	None
S0/PA0 to S15/PB7 S24/PD7 to S39/PE7	-	None	CMOS	Programmable
COM0/PL0 to COM3/PL3	-	None	Input only	None
V1/PL4 to V3/PL6	-	None	Input only	None
PWM2, PWM3	-	None	CMOS	None
XT1	-	None	Input only	None
XT2	-	None	Output for 32.768kHz crystal oscillation	None

Note 1: Attachment of Port0 programmable pull-up resistors is controllable in nibble units (P00 to 03, P04 to 07).

*1: Connect as follows to reduce noise on V_{DD} .

V_{SS1} , V_{SS2} and V_{SS3} must be connected together and grounded.

*2: The power supply for the internal memory is V_{DD1} but it uses the V_{DD2} as the power supply for ports.

When the V_{DD2} is not backed up, the port level does not become "H" even if the port latch is in the "H" level.

Therefore, when the V_{DD2} is not backed up and the port latch is "H" level, the port level is unstable in the HOLD

mode, and the back up time becomes shorter because the through current runs from V_{DD} to GND in the input buffer.

If V_{DD2} is not backed up, output "L" by the program or pull the port to "L" by the external circuit in the HOLD

mode so that the port level becomes "L" level and unnecessary current consumption is prevented.

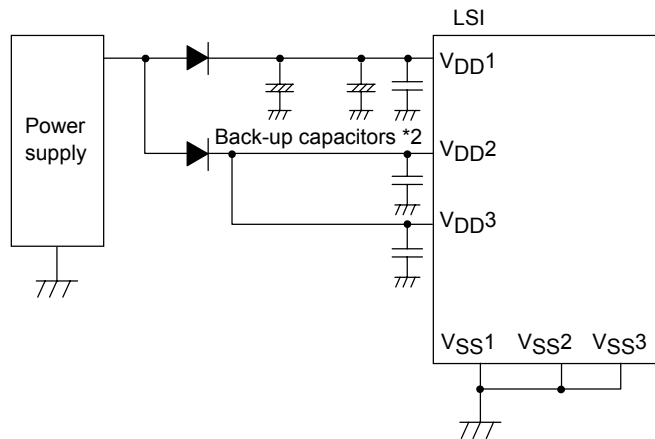

LC877C64C/56C/48C/40C/32C/24C

Absolute Maximum Ratings at Ta = 25°C, VSS1 = VSS2 = VSS3 = 0V

Parameter	Symbol	Pin/Remarks	Conditions	Specification				unit	
				VDD [V]	min	typ	max		
Supply voltage	VDD max	VDD1, VDD2, VDD3	VDD1=VDD2=VDD3		-0.3		+6.5	V	
Supply voltage for LCD	VLCD	V1/PL4, V2/PL5, V3/PL6	VDD1=VDD2=VDD3		-0.3		VDD		
Input voltage	VI	Port L XT1, XT2, CF1, \overline{RES}			-0.3		VDD+0.3		
Input/Output voltage	VI/O(1)	• Ports 0, 1, 7, 8 • Ports A, B, D, E • PWM2, PWM3			-0.3		VDD+0.3	mA	
High level output current	Peak output current	IOPH(1)	Ports 0,1	• CMOS output selected • Current at each pin		-10			
		IOPH(2)	Ports 71,72,73	Current at each pin		-5			
		IOPH(3)	• Ports A, B, D, E • PWM2, PWM3	Current at each pin		-5			
	Average output current (Note 1-1)	IOMH(1)	Ports 0,1	• CMOS output selected • Current at each pin		-7.5			
		IOMH(2)	Ports 71, 72, 73	Current at each pin		-3			
		IOMH(3)	• Ports A, B, D, E • PWM2, PWM3	Current at each pin		-3			
	Total output current	Σ IOAH(1)	• Ports 0, 1 • PWM2, PWM3	Total of all pins		-25			
			Σ IOAH(2)	Port 7	Total of all pins		-10		
			Σ IOAH(3)	Ports A, B,	Total of all pins		-25		
Σ IOAH(4)			Ports D, E	Total of all pins		-25			
Σ IOAH(5)			Ports A, B, D, E	Total of all pins		-45			
Low level output current	Peak output current	IOPL(1)	Ports 0, 1	Current at each pin			20		
		IOPL(2)	Ports 7,8	Current at each pin			10		
		IOPL(3)	• Ports A, B, D, E • PWM2, PWM3	Current at each pin			10		
	Average output current (Note 1-1)	IOML(1)	Ports 0, 1	Current at each pin			15		
		IOML(2)	Ports 7, 8	Current at each pin			7.5		
		IOML(3)	• Ports A, B, D, E • PWM2, PWM3	Current at each pin			7.5		
	Total output current	Σ IOAL(1)	• Ports 0, 1 • PWM2, PWM3	Total of all pins			45		
			Σ IOAL(2)	Ports 7, 8	Total of all pins		15		
			Σ IOAL(3)	Ports A, B	Total of all pins		45		
			Σ IOAL(4)	Ports D, E	Total of all pins		45		
Σ IOAL(5)			Ports A, B, D, E	Total of all pins		80			
Maximum power consumption	Pd max	QFP80(14×14)	Ta = -30 to +70°C				381	mW	
		TQFP80J(12×12)					325		
Operating temperature range	Topr				-30		+70	°C	
Storage temperature range	Tstg				-55		+125		

Note 1-1: Average output current indicates average value for 100ms term.

LC877C64C/56C/48C/40C/32C/24C

Allowable Operating Range at Ta = -30°C to +70°C, VSS1 = VSS2 = VSS3 = 0V

Parameter	Symbol	Pin/Remarks	Conditions	Specification							
				VDD [V]	min	typ	max	unit			
Operating supply voltage range	VDD(1)	VDD1=VDD2=VDD3	0.245μs ≤ tCYC ≤ 200μs		4.5		5.5	V			
	VDD(2)				2.8		5.5				
	VDD(3)				2.2		5.5				
Supply voltage range in Hold mode	VHD	VDD1	Keep RAM and register data in HOLD mode.		2.0		5.5				
Input high voltage	VIH(1)	• Ports 0, 8 • Ports A, B, D, E, L	Output disable	2.2 to 5.5	0.3VDD +0.7		VDD	V			
	VIH(2)	• Port 1 • Ports 71, 72, 73 • P70 port input/interrupt	Output disable	2.2 to 5.5	0.3VDD +0.7		VDD				
	VIH(3)	P87 small signal input	Output disable	2.2 to 5.5	0.75VDD		VDD				
	VIH(4)	Port 70 Watchdog timer	Output disable	2.2 to 5.5	0.9VDD		VDD				
	VIH(5)	XT1, XT2, CF1, RES		2.2 to 5.5	0.75VDD		VDD				
Input low voltage	VIL(1)	• Ports 0, 8 • Ports A, B, D, E, L	Output disable	4.0 to 5.5	VSS		0.15VDD +0.4	V			
	VIL(2)			2.2 to 4.0	VSS		0.2VDD				
	VIL(3)	• Port 1 • Ports 71, 72, 73	Output disable	4.0 to 5.5	VSS		0.1VDD +0.4				
	VIL(4)	• P70 port input/interrupt		2.2 to 4.0	VSS		0.2VDD				
	VIL(5)	Port 87 small signal Input	Output disable	2.2 to 5.5	VSS		0.25VDD				
	VIL(6)	Port 70 Watchdog timer	Output disable	2.2 to 5.5	VSS		0.8VDD -1.0				
	VIL(7)	XT1, XT2, CF1, RES		2.8 to 5.5	VSS		0.25VDD				
Operation cycle time (Note 2-1)	tCYC			4.5 to 5.5	0.245		200	μs			
				2.8 to 5.5	0.294		200				
				2.2 to 5.5	0.735		200				
External system clock frequency	FEXCF(1)	CF1	• CF2 open • system clock divider :1/1 • external clock DUTY = 50 ± 5%	4.5 to 5.5	0.1		12	MHz			
				2.8 to 5.5	0.1		10				
				2.2 to 5.5	0.1		4				
			• CF2 open • system clock divider :1/2	4.5 to 5.5	0.2		24.4				
				2.8 to 5.5	0.2		20				
				2.2 to 5.5	0.2		8				
Oscillation frequency range (Note 2-2)	FmCF(1)	CF1, CF2	12MHz ceramic resonator oscillation See Fig. 1.	4.5 to 5.5		12	MHz				
	FmCF(2)			10MHz ceramic resonator oscillation See Fig. 1.	2.8 to 5.5			10			
	FmCF(3)				4MHz ceramic resonator oscillation See Fig. 1.	2.2 to 5.5			4		
	FmRC					RC oscillation		2.2 to 5.5	0.3	1.0	2.0
	FmMRC							Frequency variable RC oscillation source oscillation	2.2 to 5.5		16
	FsX'tal	XT1, XT2	32.768kHz crystal resonator oscillation See Fig. 2.	2.2 to 5.5		32.768			kHz		

Note 2-1: Oscillation frequency and Operation cycle time (tCYC) relationship: 1/1 divide-3/FmCF, 1/2 divide-6/FmCF

Note 2-2: The parts value of oscillation circuit is shown in Table 1 and Table 2.

LC877C64C/56C/48C/40C/32C/24C

Electrical Characteristics at Ta = -30°C to +70°C, VSS1 = VSS2 = VSS3 = 0V

Parameter	Symbol	Pin/Remarks	Conditions	Specification				
				VDD [V]	min	typ	max	unit
High level input current	I _{IH} (1)	• Ports 0, 1, 7, 8 • Ports A, B, D, E, L • PWM2, PWM3	• Output disabled • Pull-up resistor OFF. • V _{IN} =V _{DD} (including OFF state leak current of the output Tr.)	2.2 to 5.5			1	μA
	I _{IH} (2)	$\overline{\text{RES}}$	V _{IN} =V _{DD}	2.2 to 5.5			1	
	I _{IH} (3)	XT1, XT2	When configured as an input port. V _{IN} =V _{DD}	2.2 to 5.5			1	
	I _{IH} (4)	CF1	V _{IN} =V _{DD}	2.2 to 5.5			15	
	I _{IH} (5)	P87/AN7/MICIN small signal input	V _{IN} =V _{BIS} +0.5V (V _{BIS} : Bias voltage)	4.5 to 5.5	5	10	20	
Low level input current	I _{IL} (1)	• Ports 0, 1, 7, 8 • Ports A, B, D, E, L • PWM2, PWM3	• Output disabled • Pull-up resistor OFF. • V _{IN} =V _{SS} (including OFF state leak current of the output Tr.)	2.2 to 5.5	-1			μA
	I _{IL} (2)	$\overline{\text{RES}}$	V _{IN} =V _{SS}	2.2 to 5.5	-1			
	I _{IL} (3)	XT1, XT2	When configured as an input port. V _{IN} =V _{SS}	2.2 to 5.5	-1			
	I _{IL} (4)	CF1	V _{IN} =V _{SS}	2.2 to 5.5	-15			
	I _{IL} (5)	P87/AN7/MICIN small signal input	V _{IN} =V _{BIS} -0.5V (V _{BIS} : Bias voltage)	4.5 to 5.5	-20	-10	-5	
High level output voltage	V _{OH} (1)	Ports 0, 1: CMOS output option	I _{OH} =-1.0mA	4.5 to 5.5	V _{DD} -1			V
	V _{OH} (2)		I _{OH} =-0.4mA	3.0 to 5.5	V _{DD} -0.4			
	V _{OH} (3)		I _{OH} =-0.2mA	2.2 to 5.5	V _{DD} -0.4			
	V _{OH} (4)	Port 7	I _{OH} =-0.4mA	3.0 to 5.5	V _{DD} -0.4			
	V _{OH} (5)		I _{OH} =-0.2mA	2.2 to 5.5	V _{DD} -0.4			
	V _{OH} (6)	• Ports A, B, D, E, • PWM2, PWM3	I _{OH} =-1.0mA	4.5 to 5.5	V _{DD} -1			
	V _{OH} (7)		I _{OH} =-0.4mA	3.0 to 5.5	V _{DD} -0.4			
	V _{OH} (8)		I _{OH} =-0.2mA	2.2 to 5.5	V _{DD} -0.4			
Low level output voltage	V _{OL} (1)	Ports 0, 1	I _{OL} =10mA	4.5 to 5.5			1.5	V
	V _{OL} (2)		I _{OL} =1.6mA	3.0 to 5.5			0.4	
	V _{OL} (3)		I _{OL} =1.0mA	2.2 to 5.5			0.4	
	V _{OL} (4)	Ports 7, 8	I _{OL} =1.6mA	3.0 to 5.5			0.4	
	V _{OL} (5)		I _{OL} =1.0mA	2.2 to 5.5			0.4	
	V _{OL} (6)	• Ports A, B, D, E, • PWM2, PWM3	I _{OL} =1.6mA	3.0 to 5.5			0.4	
	V _{OL} (7)		I _{OL} =1.0mA	2.2 to 5.5			0.4	
LCD output voltage regulation	VODLS	S0 to S15, S24 to S39	I _O =0mA VLCD, 2/3VLCD, 1/3VLCD level output See Fig. 8.	2.2 to 5.5	0		±0.2	kΩ
	VODLC	COM0 to COM3	I _O =0mA VLCD, 2/3VLCD, 1/2VLCD, 1/3VLCD level output See Fig. 8.	2.2 to 5.5	0		±0.2	
LCD bias resistor	RLCD(1)	Resistance per one bias resistor	See Fig. 8.	2.2 to 5.5		60		kΩ
	RLCD(2)	• Resistance per one bias resistor • 1/2R mode	See Fig. 8.	2.2 to 5.5		30		

Continued on next page.

LC877C64C/56C/48C/40C/32C/24C

Continued from preceding page.

Parameter	Symbol	Pin/Remarks	Conditions	Specification				
				V _{DD} [V]	min	typ	max	unit
Resistance of pull-up MOS Tr.	Rpu	• Ports 0, 1, 7 • Ports A, B, D, E	V _{OH} =0.9V _{DD}	4.5 to 5.5	15	35	80	kΩ
				2.2 to 4.5	18	50	150	
Hysteresis voltage	VHYS(1)	• Ports 1, 7 • RES		2.2 to 5.5		0.1V _{DD}		V
	VHYS(2)	Port 87 small signal input		2.2 to 5.5		0.1V _{DD}		
Pin capacitance	CP	All pins	• All Other Terminals Connected To V _{SS} . • F=1MHz • Ta=25°C	2.2 to 5.5		10		pF
Input sensitivity	Vsen	Port 87 small signal input		2.2 to 5.5	0.12V _{DD}			Vp-p

Serial Input/Output Characteristics at Ta = -30°C to +70°C, V_{SS1} = V_{SS2} = V_{SS3} = 0V

1. SIO0 Serial I/O Characteristics (Note 4-1-1)

Parameter	Symbol	Pin/Remarks	Conditions	Specification					
				V _{DD} [V]	min	typ	max	unit	
Serial clock	Input clock	Frequency	tSCK(1)	SCK0(P12) See Fig. 6.	2.2 to 5.5	2			tCYC
		Low level pulse width	tSCKL(1)			1			
		High level pulse width	tSCKH(1)			1			
			tSCKHA(1)			4			
	Output clock	Frequency	tSCK(2)	SCK0(P12) • CMOS output selected • See Fig. 6.	2.2 to 5.5	4/3			tSCK
		Low level pulse width	tSCKL(2)			1/2			
High level pulse width		tSCKH(2)	1/2						
		tSCKHA(2)	• Continuous data transmission/reception mode • CMOS output selected • See Fig. 6.		tSCKH(2) +2tCYC		tSCKH(2) +(10/3) tCYC	tCYC	
Serial input	Data setup time	tsDI(1)	SB0(P11), SI0(P11) • Must be specified with respect to rising edge of SIOCLK. • See Fig. 6.	2.2 to 5.5	0.03				
	Data hold time	thDI(1)		2.2 to 5.5	0.03				
Serial output	Input clock	Output delay time	SO0(P10), SB0(P11) • Continuous data transmission/reception mode • (Note 4-1-3)	2.2 to 5.5			(1/3)tCYC +0.05	μs	
				tdD0(2)	2.2 to 5.5				1tCYC +0.05
	Output clock	tdD0(3)		(Note 4-1-3)	2.2 to 5.5				(1/3)tCYC +0.15

Note 4-1-1: These specifications are theoretical values. Add margin depending on its use.

Note 4-1-2: To use serial-clock-input in continuous trans/rec mode, a time from SI0RUN being set when serial clock is "H" to the first negative edge of the serial clock must be longer than tSCKHA.

Note 4-1-3: Must be specified with respect to falling edge of SIOCLK. Must be specified as the time to the beginning of output state change in open drain output mode. See Fig. 6.

LC877C64C/56C/48C/40C/32C/24C

2. SIO1 Serial I/O Characteristics (Note 4-2-1)

Parameter		Symbol	Pin/Remarks	Conditions	V _{DD} [V]	Specification				
						min	typ	max	unit	
Serial clock	Input clock	Frequency	tSCK(3)	SCK1(P15)	See Fig. 6.	2.2 to 5.5	2			tCYC
		Low level pulse width	tSCKL(3)				1			
		High level pulse width	tSCKH(3)				1			
	Output clock	Frequency	tSCK(4)	SCK1(P15)	<ul style="list-style-type: none"> • CMOS output selected • See Fig. 6. 	2.2 to 5.5	2			tSCK
		Low level pulse width	tSCKL(4)				1/2			
		High level pulse width	tSCKH(4)				1/2			
Serial input	Data setup time	tsDI(2)	SB1(P14), SI1(P14)	<ul style="list-style-type: none"> • Must be specified with respect to rising edge of SIOCLK. • See Fig. 6. 	2.2 to 5.5	0.03				
	Data hold time	thDI(2)				2.2 to 5.5	0.03			
Serial output	Output delay time	tdD0(4)	SO1(P13), SB1(P14)	<ul style="list-style-type: none"> • Must be specified with respect to falling edge of SIOCLK. • Must be specified as the time to the beginning of output state change in open drain output mode. • See Fig. 6. 	2.2 to 5.5			(1/3)tCYC +0.05	μs	

Note 4-2-1: These specifications are theoretical values. Add margin depending on its use.

LC877C64C/56C/48C/40C/32C/24C

Pulse Input Conditions at Ta = -30°C to +70°C, VSS1 = VSS2 = VSS3 = 0V

Parameter	Symbol	Pin/Remarks	Conditions	Specification				
				V _{DD} [V]	min	typ	max	unit
High/low level pulse width	tPIH(1) tPIL(1)	INT0(P70), INT1(P71), INT2(P72) INT4(P30 to P33) INT5(P34 to P35)	• Condition that interrupt is accepted • Condition that event input to timer 0 is accepted	2.2 to 5.5	1			tCYC
	tPIH(2) tPIL(2)	INT3(P73) (Noise rejection ratio is 1/1.)	• Condition that interrupt is accepted • Condition that event input to timer 0 is accepted	2.2 to 5.5	2			
	tPIH(3) tPIL(3)	INT3(P73) (Noise rejection ratio is 1/32.)	• Condition that interrupt is accepted • Condition that event input to timer 0 is accepted	2.2 to 5.5	64			
	tPIH(4) tPIL(4)	INT3(P73) (Noise rejection ratio is 1/128.)	• Condition that interrupt is accepted • Condition that event input to timer 0 is accepted	2.2 to 5.5	256			
	tPIL(5) tPIL(5)	MICIN(P87)	• Condition that signal is accepted to small signal detection counter.	2.2 to 5.5	1			
	tPIL(6)	RES	• Condition that reset is accepted	2.2 to 5.5	200			

AD Converter Characteristics at Ta = -30°C to +70°C, VSS1 = VSS2 = VSS3 = 0V

Parameter	Symbol	Pin/Remarks	Conditions	Specification				
				V _{DD} [V]	min	typ	max	unit
Resolution	N	AN0(P80) to		3.0 to 5.5		8		bit
Absolute accuracy	ET	AN7(P87), AN8(P70), AN9(P71), AN10(XT1), AN11(XT2)	(Note 6-1)	3.0 to 5.5			±1.5	LSB
Conversion time	TCAD		AD conversion time=32 × tCYC (when ADCR2=0) (Note 6-2)	4.5 to 5.5	15.62 (tCYC=0.488μs)		97.92 (tCYC=3.06μs)	μs
				3.0 to 5.5	23.52 (tCYC=0.735μs)		97.92 (tCYC=3.06μs)	
			AD conversion time=64 × tCYC (when ADCR2=1) (Note 6-2)	4.5 to 5.5	18.82 (tCYC=0.294μs)		97.92 (tCYC=1.53μs)	
				3.0 to 5.5	47.04 (tCYC=0.735μs)		97.92 (tCYC=1.53μs)	
Analog input voltage range	VAIN			3.0 to 5.5	V _{SS}		V _{DD}	V
Analog port input current	IAINH		VAIN=V _{DD}	3.0 to 5.5			1	μA
	IAINL		VAIN=V _{SS}	3.0 to 5.5	-1			

Note 6-1: Absolute precision does not include quantizing error (±1/2 LSB).

Note 6-2: Conversion time means time from executing AD conversion instruction to loading complete digital value to register.

LC877C64C/56C/48C/40C/32C/24C

Consumption Current Characteristics at Ta = -30°C to +70°C, VSS1 = VSS2 = VSS3 = 0V

Parameter	Symbol	Pin/ Remarks	Conditions	Specification				
				VDD [V]	min	typ	max	unit
Current consumption during normal operation (Note 7-1)	IDDOP(1)	VDD1 = VDD2 = VDD3	<ul style="list-style-type: none"> FmCF=12MHz Ceramic resonator oscillation FsX'tal=32.768kHz crystal oscillation System clock: CF 12MHz oscillation Frequency variable RC oscillation stopped Internal RC oscillation stopped. Divider: 1/1 	4.5 to 5.5		7	12	mA
	IDDOP(2)		<ul style="list-style-type: none"> FmCF=10MHz Ceramic resonator oscillation FsX'tal=32.768kHz crystal oscillation System clock: CF 10MHz oscillation Frequency variable RC oscillation stopped Internal RC oscillation stopped. Divider: 1/1 	4.5 to 5.5		5.5	9	
	IDDOP(3)		<ul style="list-style-type: none"> FmCF=10MHz Ceramic resonator oscillation FsX'tal=32.768kHz crystal oscillation System clock: CF 10MHz oscillation Frequency variable RC oscillation stopped Internal RC oscillation stopped. Divider: 1/1 	3.0 to 3.6		3.1	5.6	
	IDDOP(4)		<ul style="list-style-type: none"> FmCF=10MHz Ceramic resonator oscillation FsX'tal=32.768kHz crystal oscillation System clock: CF 10MHz oscillation Frequency variable RC oscillation stopped Internal RC oscillation stopped. Divider: 1/1 	2.8 to 3.0		2.2	3.8	
	IDDOP(5)		<ul style="list-style-type: none"> FmCF=4MHz Ceramic resonator oscillation FsX'tal=32.768kHz crystal oscillation System clock: CF 4MHz oscillation Internal RC oscillation stopped. Frequency variable RC oscillation stopped Divider: 1/1 	4.5 to 5.5		2.5	4	
	IDDOP(6)		<ul style="list-style-type: none"> FmCF=4MHz Ceramic resonator oscillation FsX'tal=32.768kHz crystal oscillation System clock: CF 4MHz oscillation Internal RC oscillation stopped. Frequency variable RC oscillation stopped Divider: 1/1 	3.0 to 3.6		1.2	2.5	
	IDDOP(7)		<ul style="list-style-type: none"> FmCF=4MHz Ceramic resonator oscillation FsX'tal=32.768kHz crystal oscillation System clock: CF 4MHz oscillation Internal RC oscillation stopped. Frequency variable RC oscillation stopped Divider: 1/1 	2.2 to 3.0		0.9	1.8	
	IDDOP(8)		<ul style="list-style-type: none"> FmCF=0Hz (No oscillation) FsX'tal=32.768kHz crystal oscillation Frequency variable RC oscillation stopped System clock: RC oscillation Divider: 1/2 	4.5 to 5.5		0.55	2.1	
	IDDOP(9)		<ul style="list-style-type: none"> FmCF=0Hz (No oscillation) FsX'tal=32.768kHz crystal oscillation Frequency variable RC oscillation stopped System clock: RC oscillation Divider: 1/2 	3.0 to 3.6		0.3	1.4	
	IDDOP(10)		<ul style="list-style-type: none"> FmCF=0Hz (No oscillation) FsX'tal=32.768kHz crystal oscillation Frequency variable RC oscillation stopped System clock: RC oscillation Divider: 1/2 	2.2 to 3.0		0.2	1	
	IDDOP(11)		<ul style="list-style-type: none"> FmCF=0Hz (No oscillation) FsX'tal=32.768kHz crystal oscillation Internal RC oscillation stopped. System clock: 1MHz with frequency variable RC oscillation Divider: 1/2 	4.5 to 5.5		1.2	3.5	
	IDDOP(12)		<ul style="list-style-type: none"> FmCF=0Hz (No oscillation) FsX'tal=32.768kHz crystal oscillation Internal RC oscillation stopped. System clock: 1MHz with frequency variable RC oscillation Divider: 1/2 	3.0 to 3.6		0.65	2.2	
	IDDOP(13)		<ul style="list-style-type: none"> FmCF=0Hz (No oscillation) FsX'tal=32.768kHz crystal oscillation Internal RC oscillation stopped. System clock: 1MHz with frequency variable RC oscillation Divider: 1/2 	2.2 to 3.0		0.4	1.6	
	IDDOP(14)		<ul style="list-style-type: none"> FmCF=0Hz (No oscillation) FsX'tal=32.768kHz crystal oscillation System clock: 32.768kHz Internal RC oscillation stopped. Frequency variable RC oscillation stopped Divider: 1/2 	4.5 to 5.5		27	65	
	IDDOP(15)		<ul style="list-style-type: none"> FmCF=0Hz (No oscillation) FsX'tal=32.768kHz crystal oscillation System clock: 32.768kHz Internal RC oscillation stopped. Frequency variable RC oscillation stopped Divider: 1/2 	3.0 to 3.6		11	45	
	IDDOP(16)		<ul style="list-style-type: none"> FmCF=0Hz (No oscillation) FsX'tal=32.768kHz crystal oscillation System clock: 32.768kHz Internal RC oscillation stopped. Frequency variable RC oscillation stopped Divider: 1/2 	2.2 to 3.0		7	32	
Current consumption during HALT mode (Note 7-1)	IDDHALT(1)	VDD1 = VDD2 = VDD3	<ul style="list-style-type: none"> HALT mode FmCF=12MHz Ceramic resonator oscillation FsX'tal=32.768kHz crystal oscillation System clock: CF 12MHz oscillation Internal RC oscillation stopped. Frequency variable RC oscillation stopped Divider: 1/1 	4.5 to 5.5		2.5	5.3	mA
	IDDHALT(2)		<ul style="list-style-type: none"> HALT mode FmCF=10MHz Ceramic resonator oscillation FsX'tal=32.768kHz crystal oscillation System clock: CF 10MHz oscillation Internal RC oscillation stopped. Frequency variable RC oscillation stopped Divider: 1/1 	4.5 to 5.5		2	4.2	
	IDDHALT(3)		<ul style="list-style-type: none"> HALT mode FmCF=10MHz Ceramic resonator oscillation FsX'tal=32.768kHz crystal oscillation System clock: CF 10MHz oscillation Internal RC oscillation stopped. Frequency variable RC oscillation stopped Divider: 1/1 	3.0 to 3.6		1.1	2.3	
	IDDHALT(4)		<ul style="list-style-type: none"> HALT mode FmCF=10MHz Ceramic resonator oscillation FsX'tal=32.768kHz crystal oscillation System clock: CF 10MHz oscillation Internal RC oscillation stopped. Frequency variable RC oscillation stopped Divider: 1/1 	2.8 to 3.0		0.7	1.5	
	IDDHALT(5)		<ul style="list-style-type: none"> HALT mode FmCF=4MHz Ceramic resonator oscillation FsX'tal=32.768kHz crystal oscillation System clock: CF 4MHz oscillation Internal RC oscillation stopped. Frequency variable RC oscillation stopped Divider: 1/1 	4.5 to 5.5		1.2	2.6	
	IDDHALT(6)		<ul style="list-style-type: none"> HALT mode FmCF=4MHz Ceramic resonator oscillation FsX'tal=32.768kHz crystal oscillation System clock: CF 4MHz oscillation Internal RC oscillation stopped. Frequency variable RC oscillation stopped Divider: 1/1 	3.0 to 3.6		0.65	1.4	
	IDDHALT(7)		<ul style="list-style-type: none"> HALT mode FmCF=4MHz Ceramic resonator oscillation FsX'tal=32.768kHz crystal oscillation System clock: CF 4MHz oscillation Internal RC oscillation stopped. Frequency variable RC oscillation stopped Divider: 1/1 	2.2 to 3.0		0.38	0.88	

Note 7-1: The currents through the output transistors and the pull-up MOS transistors are ignored.

Continued on next page.

LC877C64C/56C/48C/40C/32C/24C

Continued from preceding page.

Parameter	Symbol	Pin/ Remarks	Conditions	Specification				
				V _{DD} [V]	min	typ	max	unit
Current consumption during HALT mode (Note 7-1)	IDDHALT(8)	V _{DD1} =V _{DD2} =V _{DD3}	HALT mode • FmCF=0Hz (Oscillation stop) • FsX'tal=32.768kHz crystal oscillation • System clock: RC oscillation • Frequency variable RC oscillation stopped • Divider: 1/2	4.5 to 5.5		0.28	1	mA
	IDDHALT(9)			3.0 to 3.6		0.15	0.7	
	IDDHALT(10)			2.2 to 3.0		0.1	0.5	
	IDDHALT(11)		HALT mode • FmCF=0Hz (No oscillation) • FsX'tal=32.768kHz crystal oscillation • Internal RC oscillation stopped. • System clock: 1MHz with frequency variable RC oscillation • Divider :1/2	4.5 to 5.5		1	2.9	
	IDDHALT(12)			3.0 to 3.6		0.55	1.8	
	IDDHALT(13)			2.2 to 3.0		0.35	1.4	
	IDDHALT(14)			HALT mode • FmCF=0Hz (Oscillation stop) • FsX'tal=32.768kHz crystal oscillation • System clock: 32.768kHz • Internal RC oscillation stopped. • Frequency variable RC oscillation stopped • Divider: 1/2	4.5 to 5.5		19	
	IDDHALT(15)		3.0 to 3.6			6.2	30	
	IDDHALT(16)		2.2 to 3.0			3.6	20	
	Current consumption during HOLD mode		IDDHOLD(1)	V _{DD1}	HOLD mode • CF1=V _{DD} or open (when using external clock)	4.5 to 5.5		
IDDHOLD(2)		3.0 to 3.6				0.015	7	
IDDHOLD(3)		2.2 to 3.0				0.009	6	
Current consumption during Date/time clock HOLD mode	IDDHOLD(4)		Date/time clock HOLD mode • CF1=V _{DD} or open (when using external clock) • FmX'tal=32.768kHz crystal oscillation	4.5 to 5.5		16	45	
	IDDHOLD(5)			3.0 to 3.6		5.5	25	
	IDDHOLD(6)			2.2 to 3.0		3	15	

Note 7-1: The currents through the output transistors and the pull-up MOS transistors are ignored.

Characteristics of a Sample Main System Clock Oscillation Circuit

The characteristics in the table bellow is based on the following conditions:

- (1) Use the standard evaluation board SANYO has provided.
- (2) Use the peripheral parts with indicated value externally.
- (3) The peripheral parts value is a recommended value of oscillator manufacturer

Table 1 Characteristics of a Sample Main System Clock Oscillator Circuit with a Ceramic Oscillator

Nominal Frequency	Vendor Name	Oscillator Name	Circuit Constant				Operating Voltage Range [V]	Oscillation Stabilization Time		Remarks
			C1 [pF]	C2 [pF]	Rf1 [Ω]	Rd1 [Ω]		typ [ms]	max [ms]	
12MHz	MURATA	CSTCE12M0G52-R0	(10)	(10)	Open	470	4.5 to 5.5	0.05	0.15	Internal C1, C2
10MHz	MURATA	CSTCE10M0G52-R0	(10)	(10)	Open	1.0k	2.8 to 5.5	0.05	0.15	Internal C1, C2
		CSTLS10M0G53-B0	(15)	(15)	Open	680	2.8 to 5.5	0.05	0.15	
4MHz	MURATA	CSTCR4M00G53-R0	(15)	(15)	Open	3.3k	2.2 to 5.5	0.05	0.15	Internal C1, C2
		CSTLS4M00G53-B0	(15)	(15)	Open	3.3k	2.2 to 5.5	0.05	0.15	

The oscillation stabilizing time is a period until the oscillation becomes stable after V_{DD} becomes higher than minimum operating voltage (See Figure 4).

Characteristics of a Sample Subsystem Clock Oscillator Circuit

The characteristics in the table bellow is based on the following conditions:

- (1) Use the standard evaluation board SANYO has provided.
- (2) Use the peripheral parts with indicated value externally.
- (3) The peripheral parts value is a recommended value of oscillator manufacturer

Table 2 Characteristics of a Sample Subsystem Clock Oscillator Circuit with a Crystal Oscillator

Nominal Frequency	Vendor Name	Oscillator Name	Circuit Constant				Operating Voltage Range [V]	Oscillation Stabilization Time		Remarks
			C3 [pF]	C4 [pF]	Rf2 [Ω]	Rd2 [Ω]		typ [s]	max [s]	
32.768kHz	SEIKO EPSON	MC-306	18	18	Open	560k	2.2 to 5.5	1.3	3.0	Applicable CL value =12.5pF

The oscillation stabilizing time is a period until the oscillation becomes stable after executing the instruction which starts the sub-clock oscillation or after releasing the HOLD mode (See Figure 4).

Note : Since the circuit pattern affects the oscillation frequency, place the oscillation-related parts as close to the oscillation pins as possible with the shortest possible pattern length.

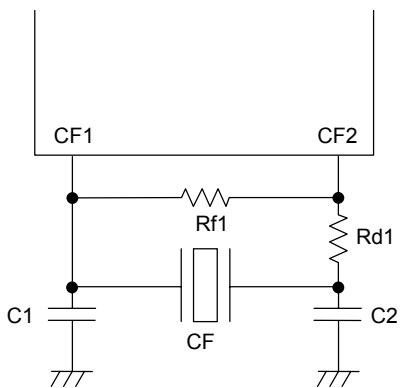

Figure 1 Ceramic Oscillator Circuit

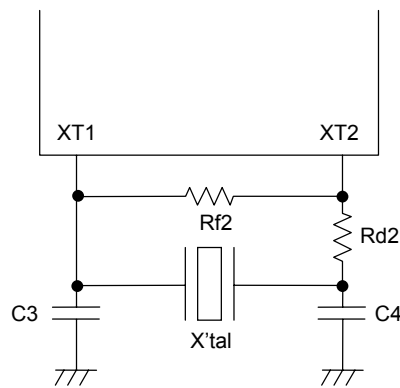

Figure 2 Crystal Oscillator Circuit

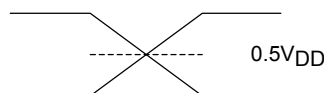
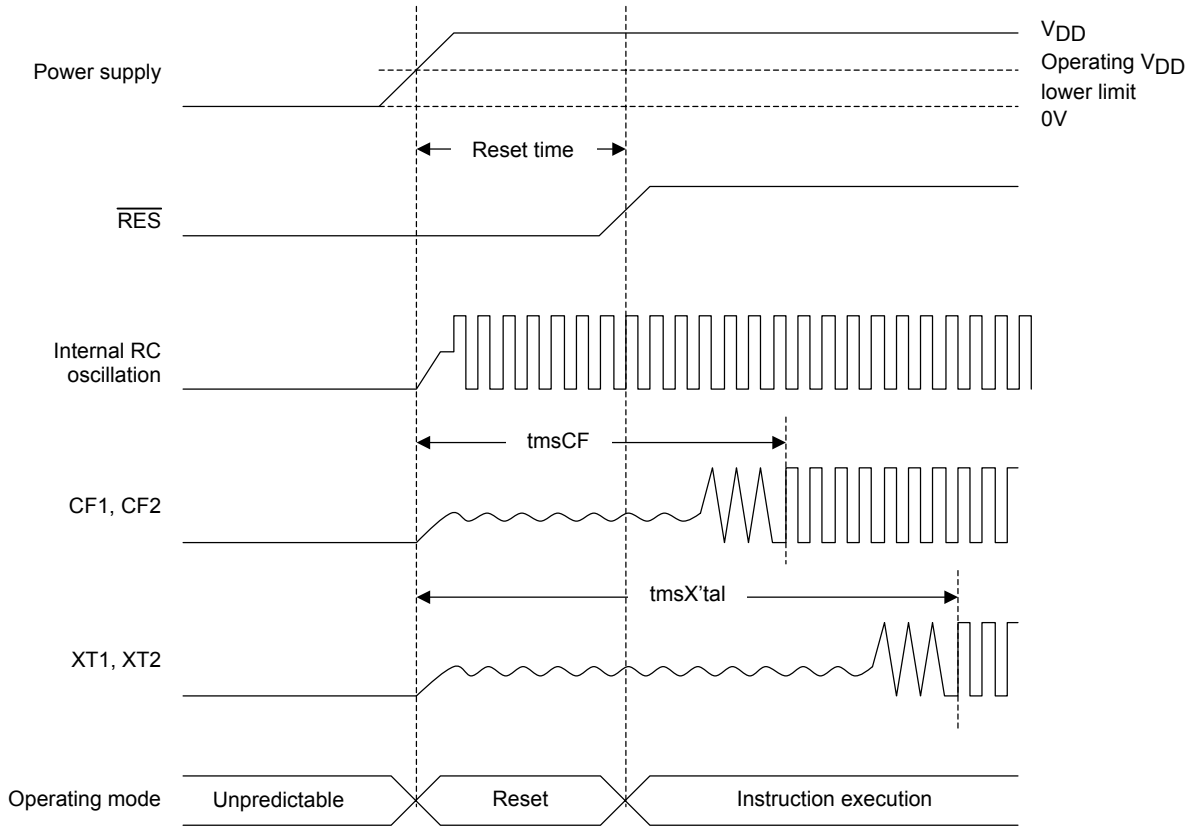
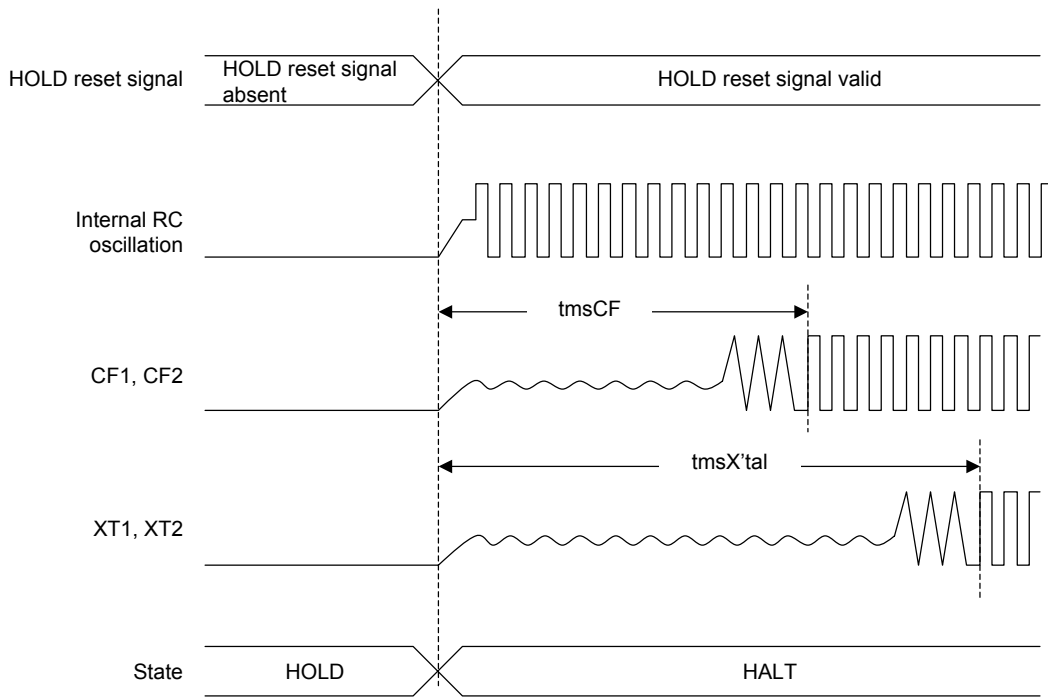

Figure 3 AC Timing Measurement Point



Reset Time and Oscillation Stabilization Time



HOLD Reset Signal and Oscillation Stabilization Time

Figure 4 Oscillation Stabilization Times

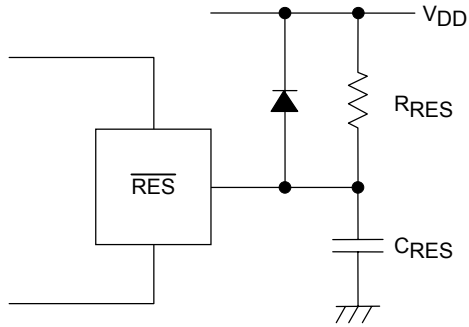

Note :
 Determine the value of C_{RES} and R_{RES} so that the reset signal is present for a period of $200\mu s$ after the supply voltage goes beyond the lower limit of the IC's operating voltage.

Figure 5 Reset Circuit

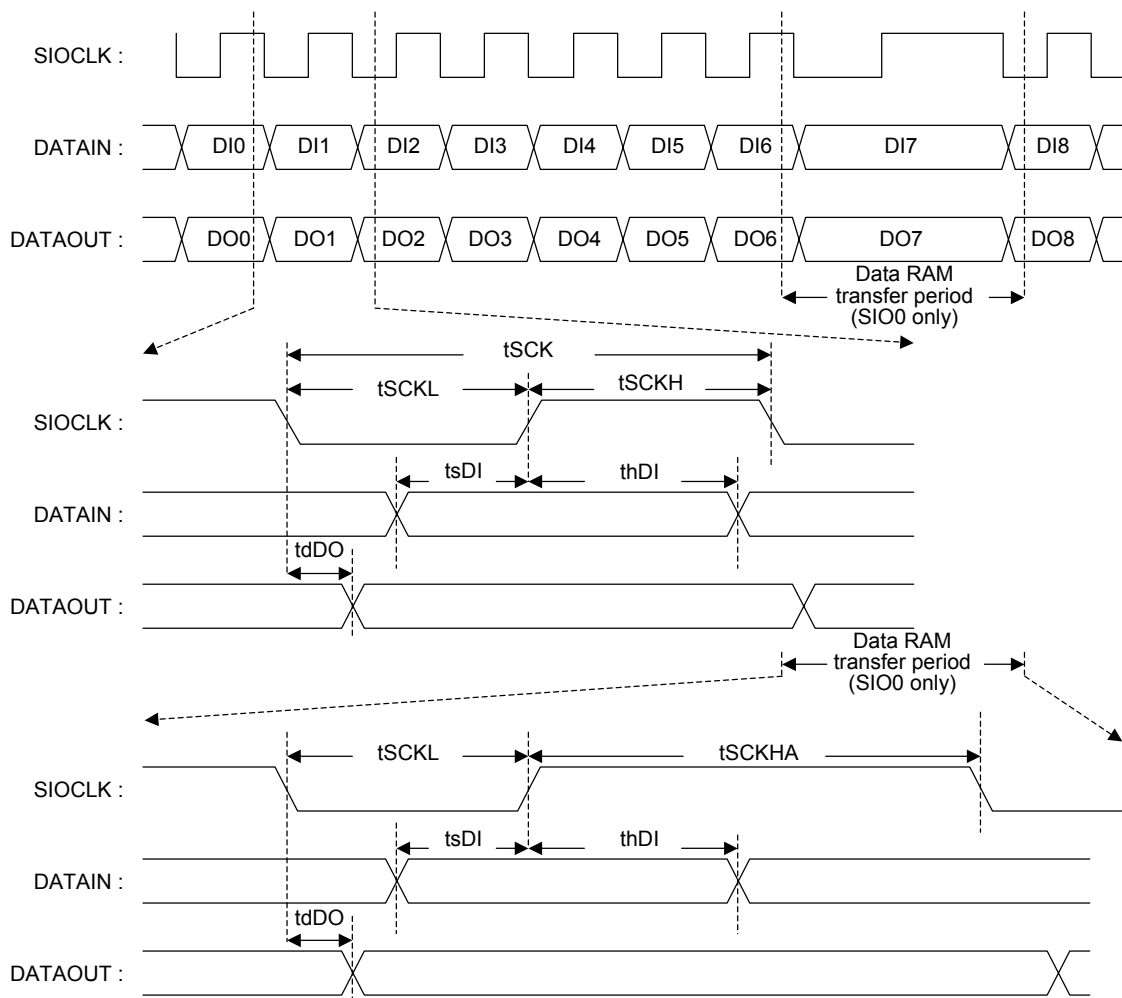

Figure 6 Serial I/O Output Waveforms

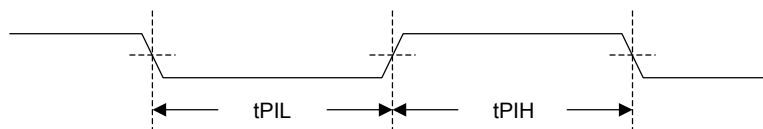

Figure 7 Pulse Input Timing Signal Waveform

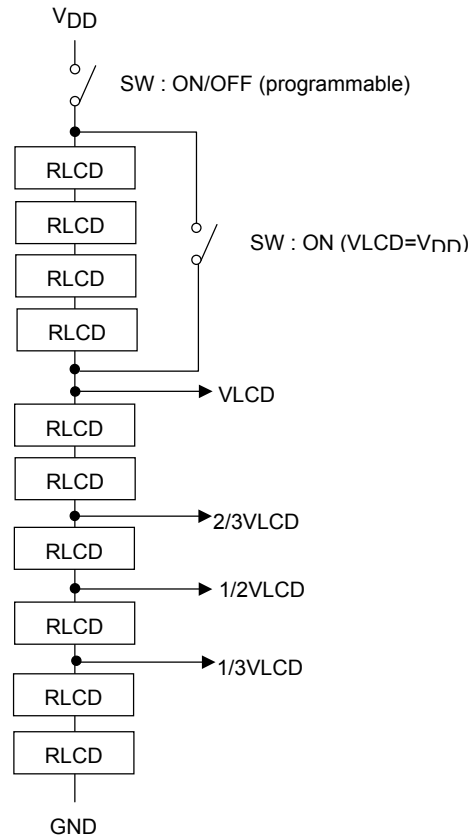

Figure 8 LCD bias resistor

- Specifications of any and all SANYO Semiconductor products described or contained herein stipulate the performance, characteristics, and functions of the described products in the independent state, and are not guarantees of the performance, characteristics, and functions of the described products as mounted in the customer's products or equipment. To verify symptoms and states that cannot be evaluated in an independent device, the customer should always evaluate and test devices mounted in the customer's products or equipment.
- SANYO Semiconductor Co., Ltd. strives to supply high-quality high-reliability products. However, any and all semiconductor products fail with some probability. It is possible that these probabilistic failures could give rise to accidents or events that could endanger human lives, that could give rise to smoke or fire, or that could cause damage to other property. When designing equipment, adopt safety measures so that these kinds of accidents or events cannot occur. Such measures include but are not limited to protective circuits and error prevention circuits for safe design, redundant design, and structural design.
- In the event that any or all SANYO Semiconductor products (including technical data, services) described or contained herein are controlled under any of applicable local export control laws and regulations, such products must not be exported without obtaining the export license from the authorities concerned in accordance with the above law.
- No part of this publication may be reproduced or transmitted in any form or by any means, electronic or mechanical, including photocopying and recording, or any information storage or retrieval system, or otherwise, without the prior written permission of SANYO Semiconductor Co., Ltd.
- Any and all information described or contained herein are subject to change without notice due to product/technology improvement, etc. When designing equipment, refer to the "Delivery Specification" for the SANYO Semiconductor product that you intend to use.
- Information (including circuit diagrams and circuit parameters) herein is for example only; it is not guaranteed for volume production. SANYO Semiconductor believes information herein is accurate and reliable, but no guarantees are made or implied regarding its use or any infringements of intellectual property rights or other rights of third parties.

This catalog provides information as of August, 2006. Specifications and information herein are subject to change without notice.