

8K EPROM HCMOS MCUs WITH A/D CONVERTER

- Single chip microcontroller, 8K bytes of EPROM and 256 bytes of register file with 224 general purpose registers available as RAM, accumulator or index pointers.
- 8/16 bit CORE with full feature DMA controller and powerful interrupt handler and a standard Serial Peripheral Interface (SPI) handling S-BUS/I²C Bus and IM BUS.
- Up to 8 external interrupts edge selectable plus 1 non-maskable interrupt.
- 16 bit programmable Timer with 8 bit Prescaler, able to be used as a Timer/Watchdog for system integrity.
- Two 16 bit Multifunction Timer modules, each with an 8 bit Prescaler and 13 operating modes, allowing simple use for complex waveform generation and measurement, PWM functions and many other system timing operations.
- 8 channel Analog to Digital Converter, with integral sample and hold, fast 11µs conversion time and 8 bit ± 1/2 LSB resolution with Analog Watchdog on two channels.
- Full function Serial Communication Interface with 110 to 375000 baud rate generator, asynchronous and byte synchronous capability (fully programmable format) and address/wake-up bit option.
- On-chip DMA channels associated with the Multifunction Timers and the Serial Communication Interface.
- Up to seven 8 bit I/O ports with programmable input thresholds and output characteristics. Alternative functions allow the full use of all pins.
- Powerful software development tools, including assembler, linker, C-compiler, archiver, software and hardware emulators.
- 68-lead Window Ceramic Leaded Chip Carrier package for ST90E30.
- 48-pin Window Dual in Line Ceramic Multilayer package for ST90E31.
- 68-lead Plastic Leaded Chip Carrier package for ST90T30.
- 48-pin Dual in Line Plastic package for ST90T31

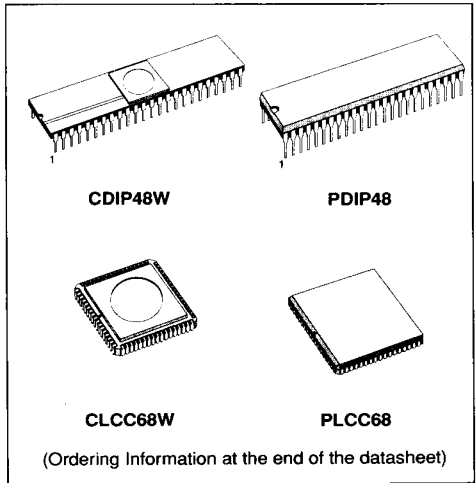

Figure 1. ST90E31,T31 Pin Configuration

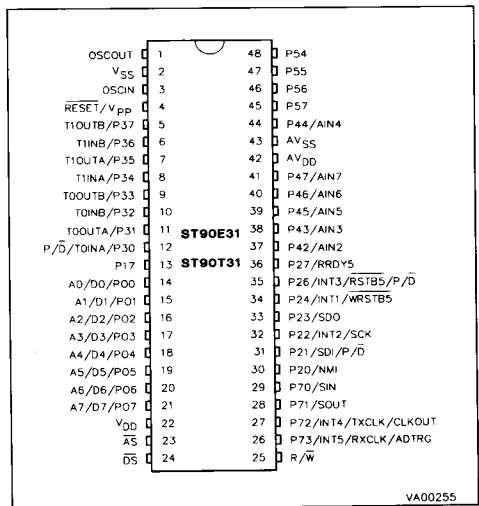
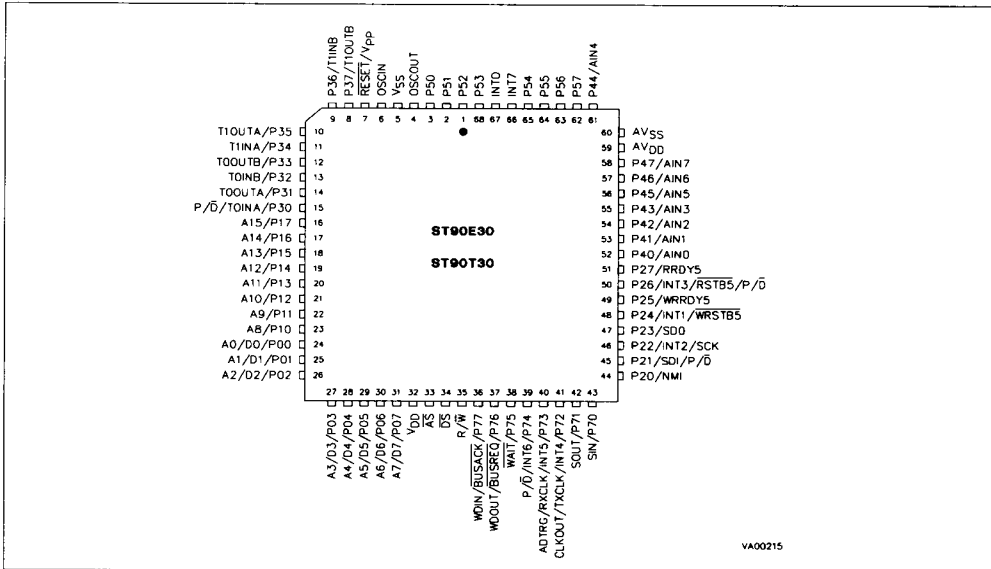
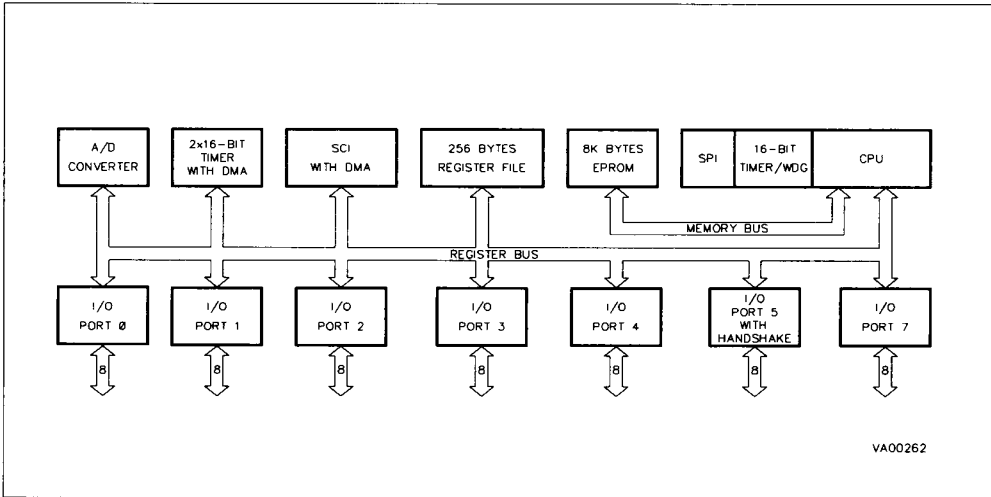

Figure 2. ST90E30,T30 Pin Configuration



VA00215

Figure 3. ST90E3X Block Diagram



VA00262

GENERAL DESCRIPTION

The ST90E30, ST90E31, ST90T30 and ST90T31 (following mentioned as ST90E3X) are EPROM members of the ST9 family of microcontrollers, in windowed ceramic (E) and plastic OTP (T) packages respectively, completely developed and produced by SGS-THOMSON Microelectronics using a proprietary n-well HCMOS process.

The EPROM parts are fully compatible with their ROM versions and this datasheet will thus provide only information specific to the EPROM based devices.

THE READER IS ASKED TO REFER TO THE DATASHEET OF THE ST9030 ROM-BASED DEVICE FOR FURTHER DETAILS.

The EPROM ST90E3X may be used for the prototyping and pre-production phases of development, and can be configured as: standalone microcontrollers with 8K bytes of on-chip ROM, microcontrollers able to manage up to bytes of external memory, or as parallel processing elements in a system with other processors and peripheral controllers.

A key point of the ST90E3X architecture is related to its modular approach which allows software commonality with all other members of the ST9 family.

The nucleus of the modular design of the ST90E3X is the advanced Core which includes the Central Processing Unit (CPU), the Register File, a 16 bit Timer/Watchdog with 8 bit Prescaler, a Serial Peripheral Interface supporting S-BUS, I²C Bus and IM BUS Interface, plus two 8 bit I/O ports. The Core has independent memory and register buses allowing a high degree of pipelining to add to the efficiency of the code execution speed of the extensive instruction set.

The powerful I/O capabilities demanded by microcontroller applications are fulfilled by the ST90E3X with up to 56 I/O lines dedicated to digital Input/Output. These lines are grouped into up to seven 8 bit I/O Ports and can be configured on a bit basis under software control to provide timing, status signals, an address/data bus for interfacing external memory, timer inputs and outputs, analog inputs, external interrupts and serial or parallel I/O with or without handshake.

Three memory spaces are available: Program Memory (internal and external), Data Memory (external) and the Register File, which includes the control and status registers of the on-chip peripherals.

Two 16 bit MultiFunction Timers, each with an 8 bit Prescaler and 13 operating modes allow simple use for complex waveform generation and measurement, PWM functions and many other system timing functions by the usage of the two associated DMA channels for each timer.

In addition there is an 8 channel Analog to Digital Converter with integral sample and hold, fast 11 μ s conversion time and 8 bit $\pm 1/2$ LSB resolution. An Analog Watchdog feature is included for two input channels.

Completing the device is a full duplex Serial Communications Interface with an integral 110 to 375000 baud rate generator, asynchronous and byte synchronous capability (fully programmable format) and associated address/wake-up option, plus two DMA channels.

PIN DESCRIPTION

AS. *Address Strobe (output, active low, 3-state).* Address Strobe is pulsed low once at the beginning of each memory cycle. The rising edge of AS indicates that address, Read/Write (R/W), and Data Memory signals are valid for program or data memory transfers. Under program control, AS can be placed in a high-impedance state along with Port 0 and Port 1, Data Strobe (DS) and R/W.

DS. *Data Strobe (output, active low, 3-state).* Data Strobe provides the timing for data movement to or from Port 0 for each memory transfer. During a write cycle, data out is valid at the leading edge of DS. During a read cycle, Data In must be valid prior to the trailing edge of DS. When the ST90E3X accesses on-chip memory, DS is held high during the whole memory cycle. It can be placed in a high impedance state along with Port 0, Port 1, AS and R/W.

R/W. *Read/Write (output, 3-state).* Read/Write determines the direction of data transfer for external memory transactions. R/W is low when writing to external program or data memory, and high for all other transactions. It can be placed in a high impedance state along with Port 0, Port 1, AS and DS.

RESET/VPP. *Reset (input, active low) or VPP (input).* The ST9 is initialised by the Reset signal. With the deactivation of RESET, program execution begins from the Program memory location pointed to by the vector contained in program memory locations 00h and 01h. In the EPROM programming Mode, this pin acts as the programming voltage input VPP.

OSCIN, OSCOUT. *Oscillator (input and output).* These pins connect a parallel-resonant crystal (24MHz maximum), or an external source to the on-chip clock oscillator and buffer. OSCIN is the input of the oscillator inverter and internal clock generator; OSCOUT is the output of the oscillator inverter.

AVDD. Analog VDD of the Analog to Digital Converter.

AVSS. Analog VSS of the Analog to Digital Converter.

VDD. Main Power Supply Voltage (5V \pm 10%).

VSS. Digital Circuit Ground.

PIN DESCRIPTION (Continued)

P00-P07, P10-P17, P20-P27, P30-P37, P40-P47, P50-P57, P70-P77. I/O Port Lines (Input/Output, TTL or CMOS compatible). 8 lines grouped into I/O ports of 8 bits, bit programmable under program control as general purpose I/O or as Alternate Functions (see next section).

I/O Port Alternate Functions. Each pin of the I/O ports of the ST90E3X may assume Alternative Functions as shown in the Pin Configuration Drawings. Due to Bonding options for the packages, some functions may not be present, Table 1 shows the Functions allocated to the I/O port pins and a summary of packages for which they are available.

Table 1. ST90E3X I/O Port Alternate Function Summary

I/O PORT Port. bit	Name	Function	Alternate Function	Pin Assignment	
				90E30	90E31
P0.0	A0/D0	I/O	Address/Data bit 0 mux	24	14
P0.1	A1/D1	I/O	Address/Data bit 1 mux	25	15
P0.2	A2/D2	I/O	Address/Data bit 2 mux	26	16
P0.3	A3/D3	I/O	Address/Data bit 3 mux	27	17
P0.4	A4/D4	I/O	Address/Data bit 4 mux	28	18
P0.5	A5/D5	I/O	Address/Data bit 5 mux	29	19
P0.6	A6/D6	I/O	Address/Data bit 6 mux	30	20
P0.7	A7/D7	I/O	Address/Data bit 7 mux	31	21
P1.0	A8	O	Address bit 8	23	-
P1.1	A9	O	Address bit 9	22	-
P1.2	A10	O	Address bit 10	21	-
P1.3	A11	O	Address bit 11	20	-
P1.4	A12	O	Address bit 12	19	-
P1.5	A13	O	Address bit 13	18	-
P1.6	A14	O	Address bit 14	17	-
P1.7	A15	O	Address bit 15	16	13
P2.0	NMI	I	Non-Maskable Interrupt	44	30
P2.1	P/D	O	Program/Data Space Select	45	31
P2.1	SDI	I	SPI Serial Data Out	45	31
P2.2	INT2	I	External Interrupt 2	46	32
P2.2	SCK	O	SPI Serial Clock	46	32
P2.3	SDO	O	SPI Serial Data In	47	33
P2.4	INT1	I	External Interrupt 1	48	34
P2.4	WRSTB5	O	Handshake Write Strobe P5	48	34
P2.5	WRRDY5	I	Handshake Write Ready P5	49	-
P2.6	INT3	I	External Interrupt 3	50	35
P2.6	RDSTB5	I	Handshake Read Strobe P5	50	35
P2.6	P/D	O	Program/Data Space Select	50	35
P2.7	RDRDY5	O	Handshake Read Ready P5	51	36
P3.0	T0INA	I	MF Timer 0 Input A	15	12
P3.0	P/D	O	Program/Data Space Select	15	12
P3.1	T0OUTA	O	MF Timer 0 Output A	14	11

PIN DESCRIPTION (Continued)

Table 1. ST90E3X I/O Port Alternate Function Summary (Continued)

I/O PORT Port. bit	Name	Function	Alternate Function	Pin Assignment	
				90E30	90E31
P3.2	T0INB	I	MF Timer 0 Input B	13	10
P3.3	T0OUTB	O	MF Timer 0 Output B	12	9
P3.4	T1INA	I	MF Timer 1 Input A	11	8
P3.5	T1OUTA	O	MF Timer 1 Output A	10	7
P3.6	T1INB	I	MF Timer 1 Input B	9	6
P3.7	T1OUTB	O	MF Timer 1 Output B	8	5
P4.0	AIN0	I	A/D Analog Input 0	52	–
P4.1	AIN1	I	A/D Analog Input 1	53	–
P4.2	AIN2	I	A/D Analog Input 2	54	37
P4.3	AIN3	I	A/D Analog Input 3	55	38
P4.4	AIN4	I	A/D Analog Input 4	61	44
P4.5	AIN5	I	A/D Analog Input 5	56	39
P4.6	AIN6	I	A/D Analog Input 6	57	40
P4.7	AIN7	I	A/D Analog Input 7	58	41
P5.0		I/O	I/O Handshake Port 5	3	–
P5.1		I/O	I/O Handshake Port 5	2	–
P5.2		I/O	I/O Handshake Port 5	1	–
P5.3		I/O	I/O Handshake Port 5	68	–
P5.4		I/O	I/O Handshake Port 5	65	48
P5.5		I/O	I/O Handshake Port 5	64	47
P5.6		I/O	I/O Handshake Port 5	63	46
P5.7		I/O	I/O Handshake Port 5	62	45
P7.0	SIN	I	SCI Serial Input	43	29
P7.1	SOUT	O	SCI Serial Output	42	28
P7.2	INT4	I	External Interrupt 4	41	27
P7.2	TXCLK	I	SCI Transmit Clock Input	41	27
P7.2	CLKOUT	O	SCI Byte Sync Clock Output	41	27
P7.3	INT5	I	External Interrupt 5	40	26
P7.3	RXCLK	I	SCI Receive Clock Input	40	26
P7.3	ADTRG	I	A/D Conversion Trigger	40	26
P7.4	INT6	I	External Interrupt 6	39	–
P7.4	P/D	O	Program/Data Space Select	39	–
P7.5	WAIT	I	External Wait Input	38	–
P7.6	WDOUT	O	T/WD Output	37	–
P7.6	BUSREQ	I	External Bus Request	37	–
P7.7	WDIN	I	T/WD Input	36	–
P7.7	BUSACK	O	External Bus Acknowledge	36	–

MEMORY

The memory of the ST90E3X is functionally divided into two areas, the Register File and Memory. The Memory may optionally be divided into two spaces, each having a maximum of 65,536 bytes. The two memory spaces are separated by function, one space for Program code, the other for Data. The ST90E3X 8K bytes of on-chip EPROM memory is selected at memory addresses 0 through 1FFFh (hexadecimal) in the Program Space, while the ST90T30 OTP version has the top 64 bytes of the program space reserved by SGS-THOMSON for testing purposes.

External memory may be addressed using the multiplexed address and data buses (Alternate

Functions of Port 0 and Port 1). At addresses greater than the first 8K of program space, the ST90E3X executes external memory cycles for instruction fetches. Data Memory may be decoded externally by using the P/D Alternate Function output. The on-chip general purpose (GP) Registers may be used as RAM memory for minimum chip count systems.

EPROM PROGRAMMING

The 8192 bytes of EPROM memory of the ST90E30 and ST90E31 (8128 for the ST90T3X) may be programmed by using the EPROM Programming Boards (EPB) available from SGS-THOMSON.

Figure 4. Memory Spaces

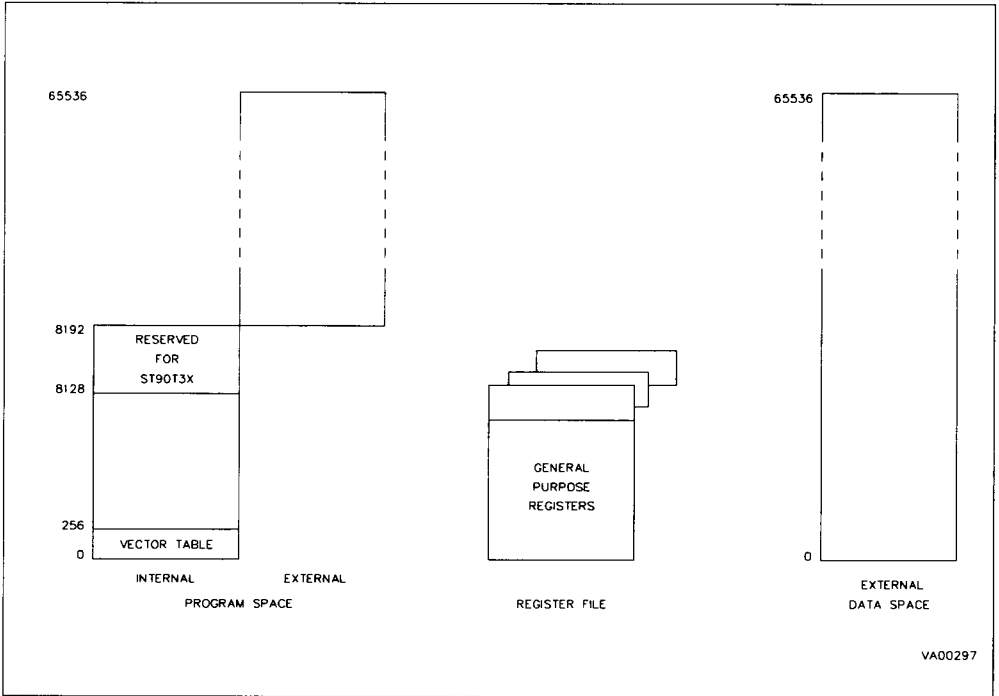

ABSOLUTE MAXIMUM RATINGS

Symbol	Parameter	Value	Unit
V _{DD}	Supply Voltage	- 0.3 to 7.0	V
AV _{DD} , AV _{SS}	Analog Supply Voltage	V _{SS} ≤ AV _{SS} < AV _{DD} ≤ V _{DD}	V
V _I	Input Voltage	V _{SS} - 0.3 to V _{DD} + 0.3	V
V _O	Output Voltage	V _{SS} - 0.3 to V _{DD} + 0.3	V
V _{PP}	Input Voltage on V _{PP} Pin	- 0.3 to 13.5	V
T _{STG}	Storage Temperature	- 55 to + 150	°C

Note: Stresses above those listed as "absolute maximum ratings" may cause permanent damage to the device. This is a stress rating only and functional operation of the device at these conditions is not implied. Exposure to maximum rating conditions for extended periods may affect device reliability.

RECOMMENDED OPERATING CONDITIONS

Symbol	Parameter	Value		Unit
		Min.	Max.	
T _A	Operating Temperature	- 40	85	°C
V _{DD}	Operating Supply Voltage	4.5	5.5	V
f _{OSCE}	External Oscillator Frequency		24	MHz
f _{OSCI}	Internal Oscillator Frequency		12	MHz

DC ELECTRICAL CHARACTERISTICS

(V_{DD} = 5V ± 10% T_A = - 40 °C to + 85°C, unless otherwise specified)

Symbol	Parameter	Test Conditions	Value			Unit
			Min.	Typ.	Max.	
V _{IHCK}	Clock Input High Level	External Clock	0.7 V _{DD}		V _{DD} + 0.3	V
V _{ILCK}	Clock Input Low Level	External Clock	- 0.3		0.3 V _{DD}	V
V _{IH}	Input High Level	TTL	2.0		V _{DD} + 0.3	V
		CMOS	0.7 V _{DD}		V _{DD} + 0.3	V
V _{IL}	Input Low Level	TTL	- 0.3		0.8	V
		CMOS	- 0.3		0.3 V _{DD}	V
V _{IHRS}	Reset Input High Level		0.7 V _{DD}		V _{DD} + 0.3	V
V _{ILRS}	Reset Input Low Level		- 0.3		0.3 V _{DD}	V
V _{HYRS}	Reset Input Hysteresis		0.3		1.5	V
V _{OH}	Output High Level	Push Pull, I _{load} = - 0.8mA	V _{DD} - 0.8			V
V _{OL}	Output Low Level	Push Pull or Open Drain, I _{load} = - 1.6mA			0.4	V
I _{WPU}	Weak Pull-up Current	Bidirectional Weak Pull-up, V _{OL} = 0V	- 80	- 200	- 420	µA

DC ELECTRICAL CHARACTERISTICS (continued)

Symbol	Parameter	Test Conditions	Value			Unit
			Min.	Typ.	Max.	
I _{APU}	Active Pull-up Current, for INT0 and INT7 only	V _{IN} < 0.8V	- 80	- 200	- 420	μA
I _{LKIO}	I/O Pin Input Leakage	Input/Tri-State, 0V < V _{IN} < V _{DD}	- 10		+ 10	μA
I _{LKRS}	Reset Pin Input Leakage	0V < V _{IN} < V _{DD}	- 30		+ 30	μA
I _{LKAD}	A/D Pin Input Leakage	Alternate Function, Open Drain, 0V < V _{IN} < V _{DD}	- 3		+ 3	μA
I _{LKAP}	Active Pull-up Input Leakage	0V < V _{IN} < 0.8V	- 10		+ 10	μA
I _{LKOS}	OSCIN Pin Input Leakage	0V < V _{IN} < V _{DD}	- 10		+ 10	μA
I _{DD}	Run Mode Current	24MHz, Note 1		32	70	mA
		4MHz, Note 1		6	12	mA
I _{DP2}	Run Mode Current Prescale by 2	24MHz, Note 1		19	40	mA
		4MHz, Note 1		4	8	mA
I _{WFI}	WFI Mode Current	24MHz, Note 1		9	18	mA
		4MHz, Note 1		2.5	5	mA
I _{HALT}	HALT Mode Current	24MHz, Note 1			100	μA
V _{PP}	EPROM Programming Voltage		12.2	12.5	12.8	V
I _{PP}	EPROM Programming Current				30	mA

Note: 1. All I/O Ports are configured in Bidirectional Weak Pull-up Mode with no DC load, External Clock pin (OSCIN) is driven by square wave external clock. No peripheral working. External interface not active (Internal Program Execution).

DC TEST CONDITIONS

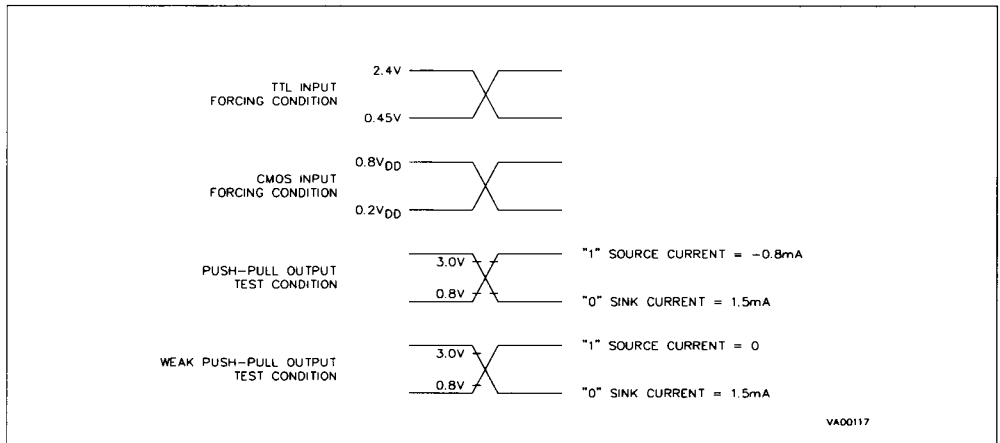

AC ELECTRICAL CHARACTERISTICS

CLOCK TIMING TABLE

(V_{DD} = 5V ± 10%, T_A = - 40°C to + 85°C, unless otherwise specified)

N°	Symbol	Parameter	Value		Unit	Note
			Min.	Max.		
1	TpC	OSCIN Clock Period	41.5		ns	a
			83		ns	b
2	TrC, TfC	OSCIN Rise and Fall Time		12	ns	
3	TwCL, TwCH	OSCIN Low and High Width	25	12	ns	a
			38		ns	b

Notes:

- a. Clock divided by 2 internally (MODER.DIV2=1)
b. Clock not divided by 2 internally (MODER.DIV2=0)

CLOCK TIMING

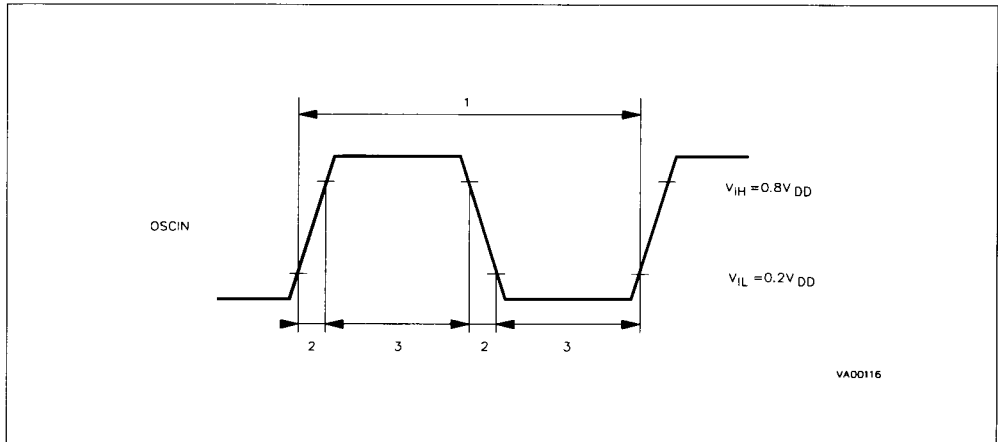

EXTERNAL BUS TIMING TABLE ($V_{DD} = 5V \pm 10\%$, $T_A = -40\text{ }^\circ\text{C}$ to $+85\text{ }^\circ\text{C}$, $C_{load} = 50\text{pF}$, $INTCLK = 12\text{MHz}$, unless otherwise specified)

N°	Symbol	Parameter	Value (Note)				Unit
			OSCIN Divided By 2	OSCIN Not Divided By 2	Min.	Max.	
1	TsA (AS)	Address Set-up Time before $\overline{AS} \uparrow$	$TpC (2P+1) -22$	$TwCH+PTpC -18$	20		ns
2	ThAS (A)	Address Hold Time after $\overline{AS} \uparrow$	$TpC -17$	$TwCL -13$	25		ns
3	TdAS (DR)	$\overline{AS} \uparrow$ to Data Available (read)	$TpC (4P+2W+4) -52$	$TpC (2P+W+2) -51$		115	ns
4	TwAS	\overline{AS} Low Pulse Width	$TpC (2P+1) -7$	$TwCH+PTpC -3$	35		ns
5	TdAz (DS)	Address Float to $\overline{DS} \downarrow$	0	0	0		ns
6	TwDSR	\overline{DS} Low Pulse Width (read)	$TpC (4P+2W+3) -20$	$TwCH+TpC (2P+W+1) -16$	105		ns
7	TwDSW	\overline{DS} Low Pulse Width (write)	$TpC (2P+2W+2) -13$	$TpC (P+W+1) -13$	70		ns
8	TdDSR (DR)	$\overline{DS} \downarrow$ to Data Valid Delay (read)	$TpC (4P+2W-3) -50$	$TwCH+TpC(2P+W+1) -46$		75	ns
9	ThDR (DS)	Data to $\overline{DS} \uparrow$ Hold Time (read)	0	0	0		ns
10	TdDS (A)	$\overline{DS} \uparrow$ to Address Active Delay	$TpC -7$	$TwCL -3$	35		ns
11	TdDS (AS)	$\overline{DS} \uparrow$ to $\overline{AS} \downarrow$ Delay	$TpC -18$	$TwCL -14$	24		ns
12	TsR/W (AS)	R/ \overline{W} Set-up Time before $\overline{AS} \uparrow$	$TpC (2P+1) -22$	$TwCH+PTpC -18$	20		ns
13	TdDSR (R/W)	$\overline{DS} \uparrow$ to R/ \overline{W} and Address Not Valid Delay	$TpC -9$	$TwCL -5$	33		ns
14	TdDW (DSW)	Write Data Valid to $\overline{DS} \downarrow$ Delay (write)	$TpC (2P+1) -32$	$TwCH+PTpC -28$	10		ns
15	ThDS (DW)	Data Hold Time after DS \uparrow (write)	$TpC -9$	$TwCL -5$	33		ns
16	TdA (DR)	Address Valid to Data Valid Delay (read)	$TpC (6P+2W+5) -68$	$TwCH+TpC (3P+W+2) -64$		140	ns
17	TdAs (DS)	$\overline{AS} \uparrow$ to $\overline{DS} \downarrow$ Delay	$TpC -18$	$TwCL -14$	24		ns

Note: The value left hand two columns show the formula used to calculate the timing minimum or maximum from the oscillator clock period, prescaler value and number of wait cycles inserted.

The value right hand two columns show the timing minimum and maximum for an external clock at 24 MHz divided by 2, prescaler value of zero and zero wait status.

Legend:

P = Clock Prescaling Value

W = Wait Cycles

TpC = OSCIN Period

TwCH = High Level OSCIN half period

TwCL = Low Level OSCIN half period

EXTERNAL BUS TIMING

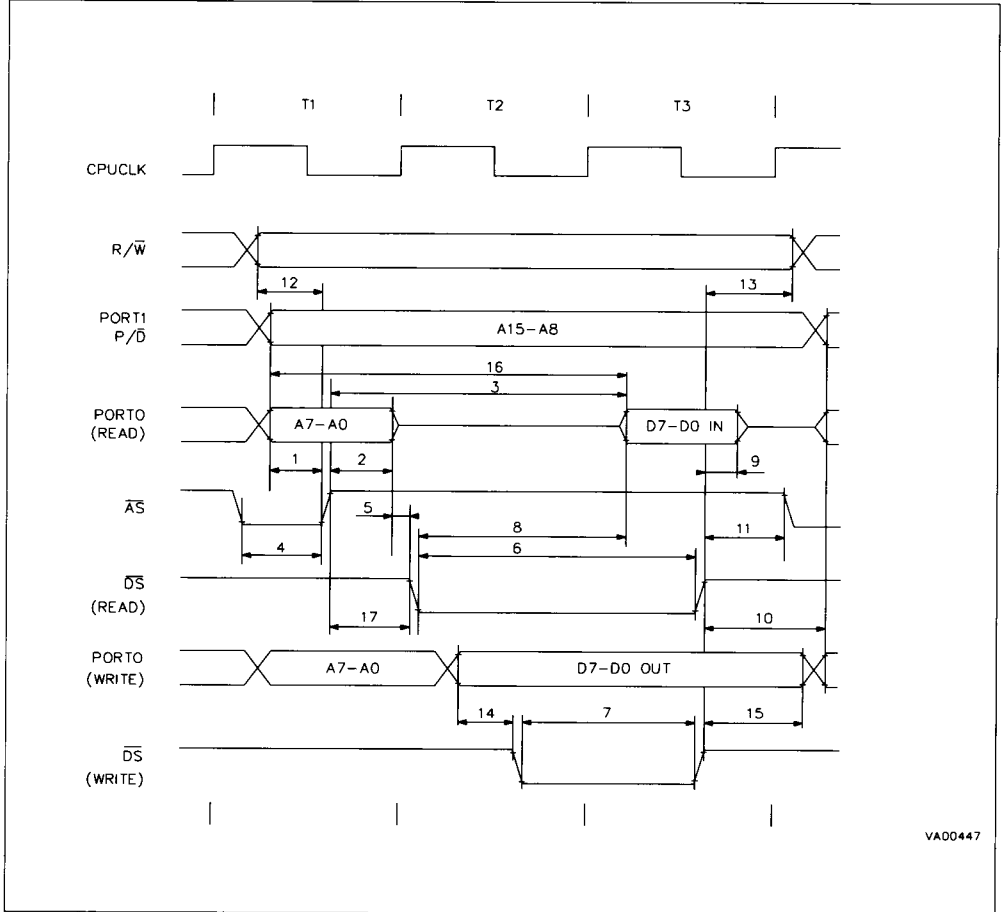

EXTERNAL WAIT TIMING TABLE ($V_{DD} = 5V \pm 10\%$, $T_A = -40^\circ C$ to $+85^\circ C$, $C_{load} = 50pF$, $INTCLK = 12MHz$, Push-pull output configuration, unless otherwise specified)

N°	Symbol	Parameter	Value (Note)				Unit
			OSCIN Divided By 2	OSCIN Not Divided By 2	Min.	Max.	
1	TdAS (WAIT)	AS ↑ to WAIT ↓ Delay	$2(P+1)TpC - 29$	$(P+1)TpC - 29$		40	ns
2	TdAS (WAIT)	AS ↑ to WAIT ↑ Minimum Delay	$2(P+W+1)TpC - 4$	$(P+W+1)TpC - 4$	80		ns
3	TdAS (WAIT)	AS ↑ to WAIT ↑ Maximum Delay	$2(P+W+1)TpC - 29$	$(P+W+1)TpC - 29$		$83W+40$	ns

Note: The value left hand two columns show the formula used to calculate the timing minimum or maximum from the oscillator clock period, prescale value and number of wait cycles inserted.
The value right hand two columns show the timing minimum and maximum for an external clock at 24 MHz divided by 2, prescale value of zero and zero wait status.

EXTERNAL WAIT TIMING

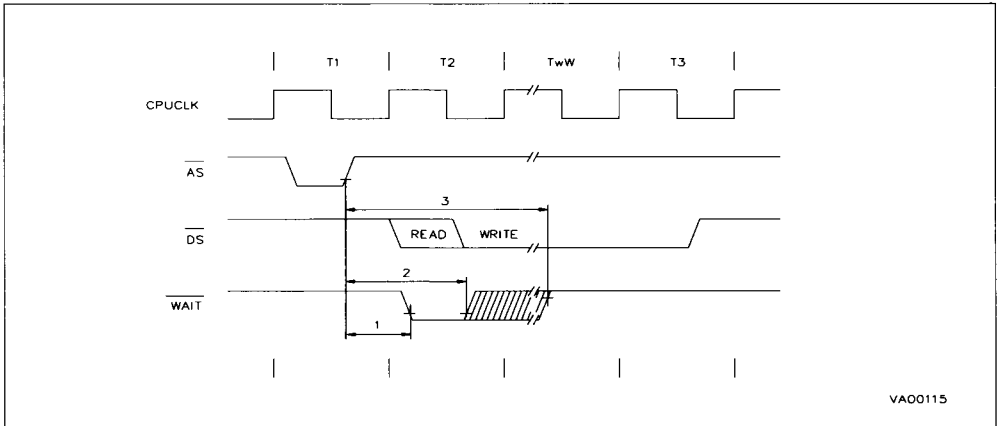

VA00115

BUS REQUEST/ACKNOWLEDGE TIMING TABLE ($V_{DD} = 5V \pm 10\%$, $T_A = -40^\circ\text{C}$ to $+85^\circ\text{C}$, $C_{load} = 50\text{pF}$, $\text{INTCLK} = 12\text{MHz}$, Push-pull output configuration, unless otherwise specified)

N°	Symbol	Parameter	Value (Note)				Unit
			OSCIN Divided By 2	OSCIN Not Divided By 2	Min.	Max.	
1	TdBR (BACK)	BREQ ↓ to BUSACK ↓	$T_{pC}+8$	$T_{wCL}+12$	50		ns
			$T_{pC}(6P+2W+7)+65$	$T_{pC}(3P+W+3)+T_{wCL}+65$		360	ns
2	TdBR (BACK)	BREQ ↑ to BUSACK ↑	$3T_{pC}+60$	$T_{pC}+T_{wCL}+60$		185	ns
3	TdBACK (BREL)	BUSACK ↓ to Bus Release	20	20		20	ns
4	TdBACK (BACT)	BUSACK ↑ to Bus Active	20	20		20	ns

Note: The value left hand two columns show the formula used to calculate the timing minimum or maximum from the oscillator clock period, prescale value and number of wait cycles inserted.
The value right hand two columns show the timing minimum and maximum for an external clock at 24 MHz divided by 2, prescale value of zero and zero wait status.

BUS REQUEST/ACKNOWLEDGE TIMING

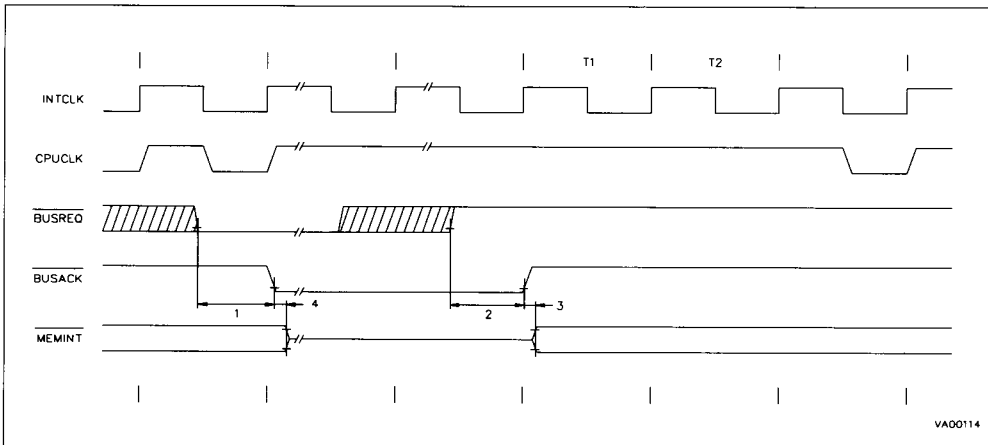

Note : MEMINT = group of memory interface signals : AS, DS, R/W, P00-P07, P10-P17.

HANDSHAKE TIMING TABLE ($V_{DD} = 5V \pm 10\%$, $T_A = -40^\circ\text{C}$ to $+85^\circ\text{C}$, $\text{Load} = 50\text{pF}$, $\text{INTCLK} = 12\text{MHz}$, Push-pull output configuration, unless otherwise specified)

N°	Symbol	Parameter	Value (Note)				Min.	Max.	Unit
			OSCIN Divided By 2		OSCIN Not Divided By 2				
			Min.	Max.	Min.	Max.			
1	TwRDY	RDRDY, WRRDY Pulse Width in One Line Handshake	$2T_{pC} (P+W+1) - 18$		$T_{pC} (P+W+1) - 18$		65		ns
2	TwSTB	RDSTB, WRSTB Pulse Width	$2T_{pC} + 12$		$T_{pC} + 12$		95		ns
3	TdST (RDY)	RDSTB, or WRSTB \uparrow to RDRDY or WRRDY \downarrow		$T_{pC} + 45$		$(T_{pC} - TwCL) + 45$		87	ns
4	TsPD (RDY)	Port Data to RDRDY \uparrow Set-up Time	$(2P+2W+1) T_{pC} - 25$		$TwCH+(W+P) T_{pC} - 25$		16		ns
5	TsPD (RDY)	Port Data to WRRDY \downarrow Set-up Time in One Line Handshake	43		43		43		ns
6	ThPD (RDY)	Port Data to WRRDY \downarrow Hold Time in One Line Handshake	0		0		0		ns
7	TsPD (STB)	Port Data to WRSTB \uparrow Set-up Time	10		10		10		ns
8	ThPD (STB)	Port Data to WRSTB \uparrow Hold Time	25		25		25		ns
9	TdSTB (PD)	RDSTBD \uparrow to Port Data Delay Time in Bidirectional Handshake		35		35		35	ns
10	TdSTB (PHZ)	RDSTB \uparrow to Port High-Z Delay Time in Bidirectional Handshake		25		25		25	ns

Note: The value left hand two columns show the formula used to calculate the timing minimum or maximum from the oscillator clock period, prescale value and number of wait cycles inserted.
The value right hand two columns show the timing minimum and maximum for an external clock at 24 MHz divided by 2, prescaler value of zero and zero wait status.

Legend:

P = Clock Prescaling Value (R235.4,3,2)

W = Programmable Wait Cycles (R252.2.1.0/5,4,3) + External Wait Cycles

HANDSHAKE TIMING

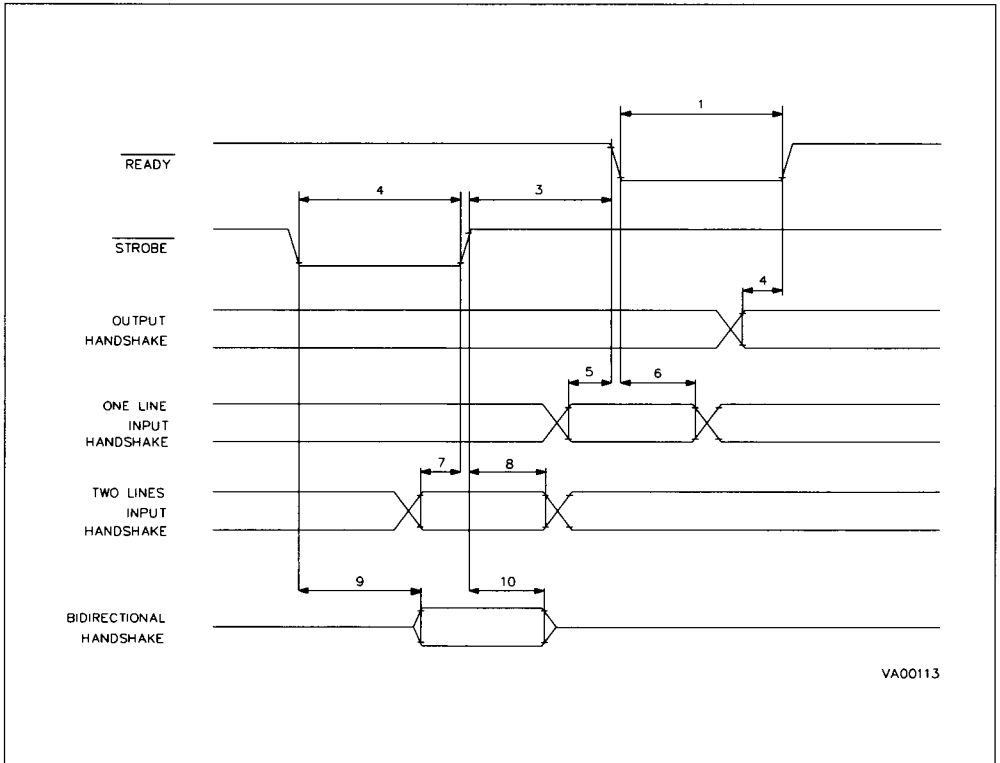

EXTERNAL INTERRUPT TIMING TABLE ($V_{DD} = 5V \pm 10\%$, $T_A = -40^{\circ}C$ to $+85^{\circ}C$, $C_{load} = 50pF$, $INTCLK = 12MHz$, Push-pull output configuration, unless otherwise specified)

N°	Symbol	Parameter	Value (Note)				Unit
			OSCIN Divided By 2 Min.	OSCIN Not Divided By 2 Min.	Min.	Max.	
1	TwLR	Low Level Minimum Pulse Width in Rising Edge Mode	$2T_{pC}+12$	$T_{pC}+12$	95		ns
2	TwHR	High Level Minimum Pulse Width in Rising Edge Mode	$2T_{pC}+12$	$T_{pC}+12$	95		ns
3	TwHF	High Level Minimum Pulse Width in Falling Edge Mode	$2T_{pC}+12$	$T_{pC}+12$	95		ns
4	TwLF	Low Level Minimum Pulse Width in Falling Edge Mode	$2T_{pC}+12$	$T_{pC}+12$	95		ns

Note: The value left hand two columns show the formula used to calculate the timing minimum or maximum from the oscillator clock period, prescale value and number of wait cycles inserted.
 The value right hand two columns show the timing minimum and maximum for an external clock at 24 MHz divided by 2, prescale value of zero and zero wait status.

EXTERNAL INTERRUPT TIMING

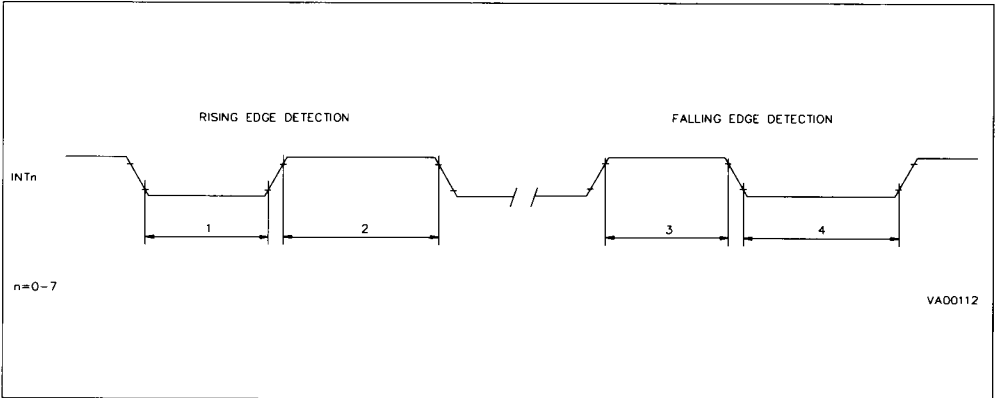

WATCHDOG TIMING TABLE ($V_{DD} = 5V \pm 10\%$, $T_A = -40^\circ\text{C}$ to $+85^\circ\text{C}$, $C_{load} = 50\text{pF}$, $\text{INTCLK} = 12\text{MHz}$, Output Alternate Function set as Push-pull)

N°	Symbol	Parameter	Value		Unit
			Min.	Max.	
1	T_{wWDOL}	WDOU Low Pulse Width	620		ns
2	T_{wWDOH}	WDOU High Pulse Width	620		ns
3	T_{wWDIL}	WDIN Low Pulse Width	350		ns
4	T_{wWDIH}	WDIN High Pulse Width	350		ns

WATCHDOG TIMING

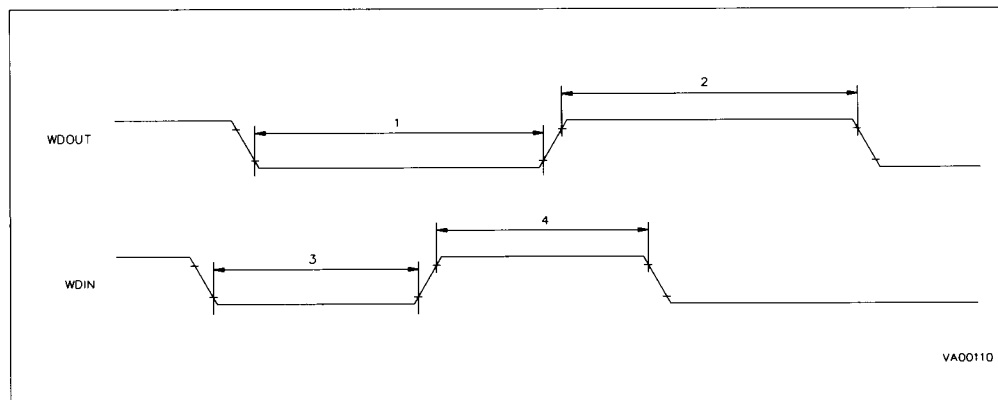

SPI TIMING TABLE ($V_{DD} = 5V \pm 10\%$, $T_A = -40^{\circ}C$ to $+85^{\circ}C$, $C_{load} = 50pF$, $INTCLK = 12MHz$, Output Alternate Function set as Push-pull)

N°	Symbol	Parameter	Value		Unit
			Min.	Max.	
1	TsDI	Input Data Set-up Time	100		ns
2	ThDI (1)	Input Data Hold Time	$1/2 T_{pC} + 100$		ns
3	TdOV	SCK to Output Data Valid		100	ns
4	ThDO	Output Data Hold Time	-20		ns
5	TwSKL	SCK Low Pulse Width	300		ns
6	TwSKH	SCK High Pulse Width	300		ns

Note: 1. T_{pC} is the Clock period.

SPI TIMING

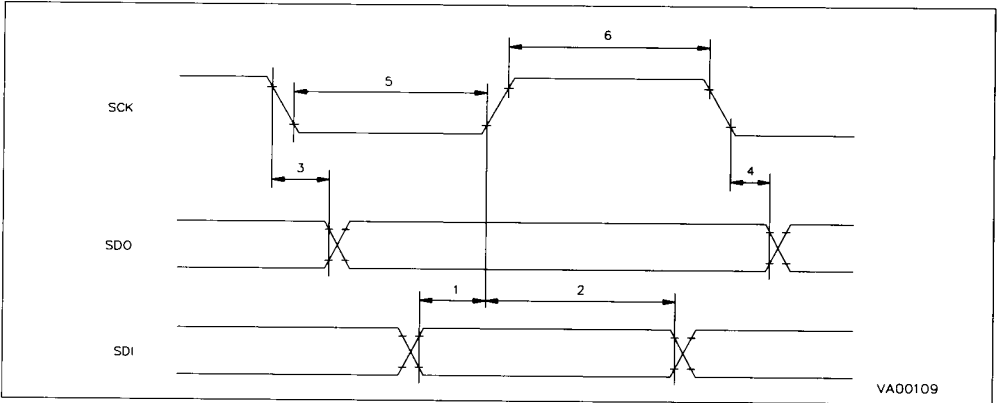

PACKAGES MECHANICAL DATA

Figure 5. 48-Pin Window Dual In Line Ceramic Multilayer (D), 600-Mil Width

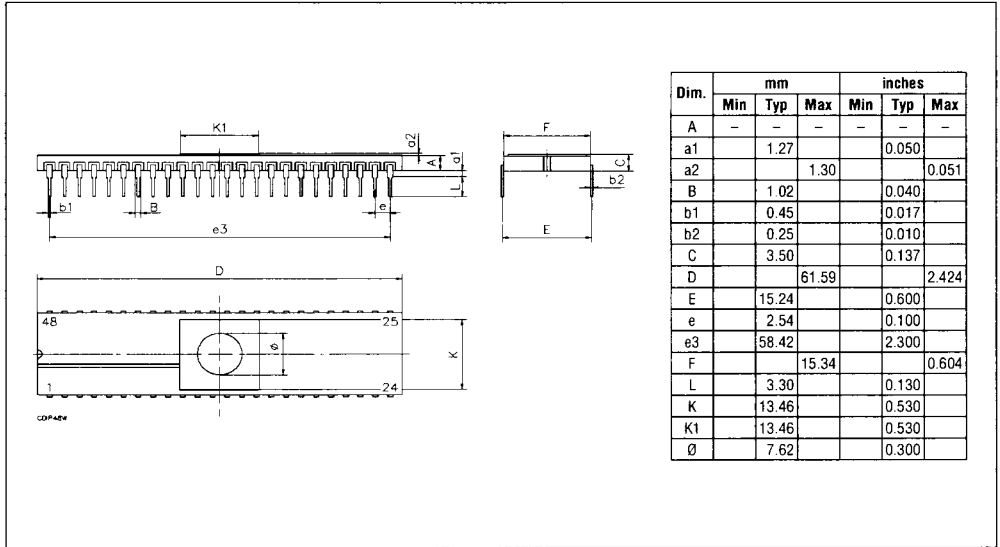
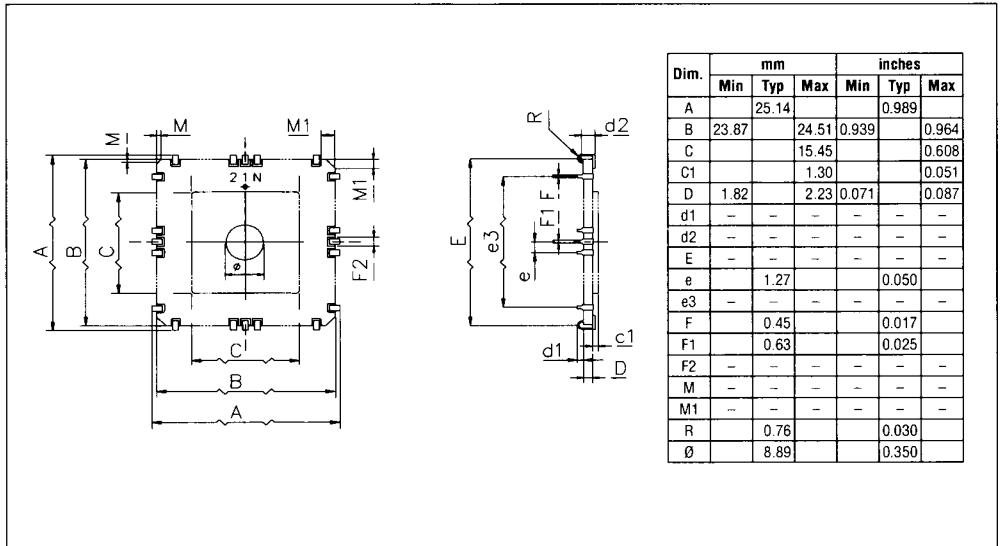

Figure 6. 68-Lead Window Ceramic Leaded Chip Carrier (L)



PACKAGES MECHANICAL DATA (continued)

Figure 7. 48-Pin Dual In Line Plastic (B), 600-Mil Width

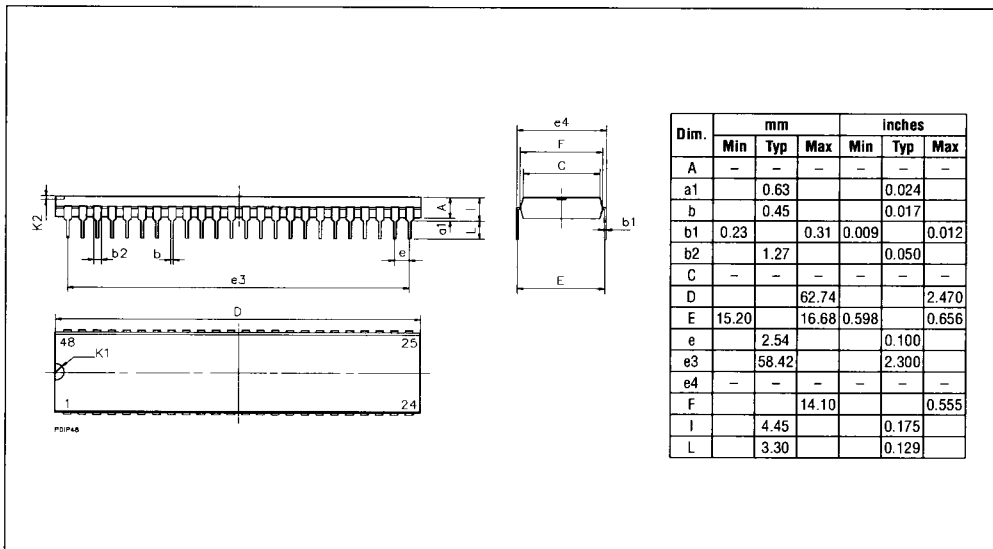
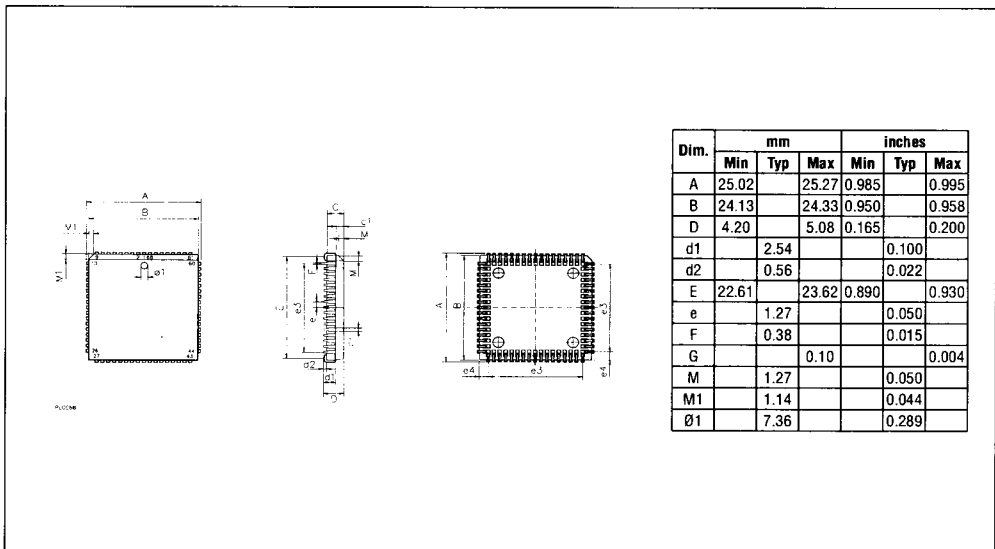

Figure 8. 68-Lead Plastic Leaded Chip Carrier (C)



ORDERING INFORMATION

Sales Type	Frequency	Temperature Range	Package
ST90E30L6	24MHz	- 40°C to + 85°C	CLCC68W
ST90T30C6	24MHz	- 40°C to + 85°C	PLCC68
ST90E31D6	24MHz	- 40°C to + 85°C	CDIP48W
ST90T31B6	24MHz	- 40°C to + 85°C	PDIP48
ST90E30L1	24MHz	0°C to +70°C	CLCC68W
ST90T30C1	24MHz	0°C to +70°C	PLCC68
ST90E31D1	24MHz	0°C to +70°C	CDIP48W
ST90T31B1	24MHz	0°C to +70°C	PDIP48