

PLEASE CHECK WWW.MOLEX.COM FOR LATEST PART INFORMATION

Part Number: [5020783910](#)
Status: **Active**
Description: 0.25mm (.010") Pitch Easy-On™ Type FPC Connector, 1.00mm (.039") Mated Height, Right Angle, SMT, Bottom Contact Style, 39 Circuits, Halogen Free

Documents:

[3D Model](#) [Product Specification PS-502078-002 \(PDF\)](#)
[Drawing \(PDF\)](#) [RoHS Certificate of Compliance \(PDF\)](#)

General

Product Family FFC/FPC Connectors
 Series [502078](#)
 Product Name Easy-On™

Physical

Circuits (Loaded) 39
 Contact Position Bottom
 Durability (mating cycles max) 10
 Entry Angle 90° Angle
 Mated Height (in) 0.039 In
 Mated Height (mm) 1.00 mm
 Material - Metal Copper Alloy
 Material - Plating Mating Gold
 Material - Plating Termination Gold
 Number of Rows 1
 Orientation Right Angle
 PCB Locator No
 PCB Retention Yes
 Packaging Type Embossed Tape on Reel
 Pitch - Mating Interface (in) 0.010 In
 Pitch - Mating Interface (mm) 0.25 mm
 Polarized to PCB Yes
 Stackable No
 Temperature Range - Operating -20°C to +85°C
 Termination Interface: Style Surface Mount
 Wire/Cable Type FPC only

Electrical

Current - Maximum per Contact 0.2A
 Voltage - Maximum 50V

Material Info

Reference - Drawing Numbers

Product Specification PS-502078-002, RPS-502078-005, RPS-502078-006, RPS-502078-007
 Sales Drawing SD-502078-003, SD-502078-004

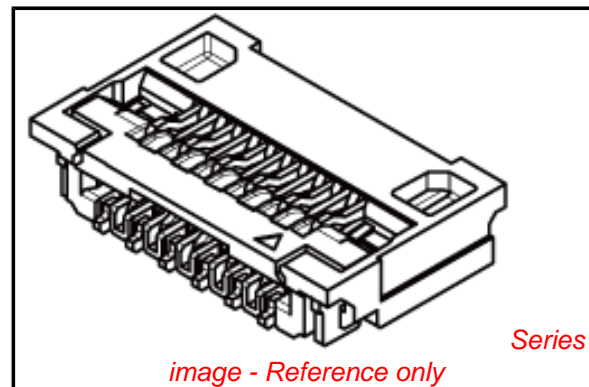

image - Reference only

EU RoHS

ELV and RoHS Compliant
REACH SVHC
 Not Reviewed
Halogen-Free Status
Not Reviewed

China RoHS



Need more information on product environmental compliance?

Email productcompliance@molex.com
 For a multiple part number RoHS Certificate of Compliance, [click here](#)

Please visit the [Contact Us](#) section for any non-product compliance questions.

Search Parts in this Series
[502078Series](#)

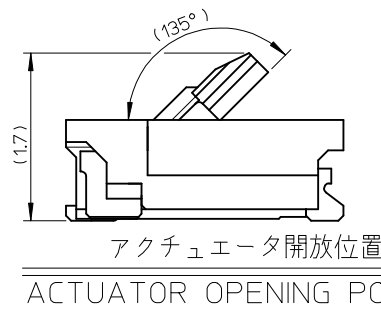
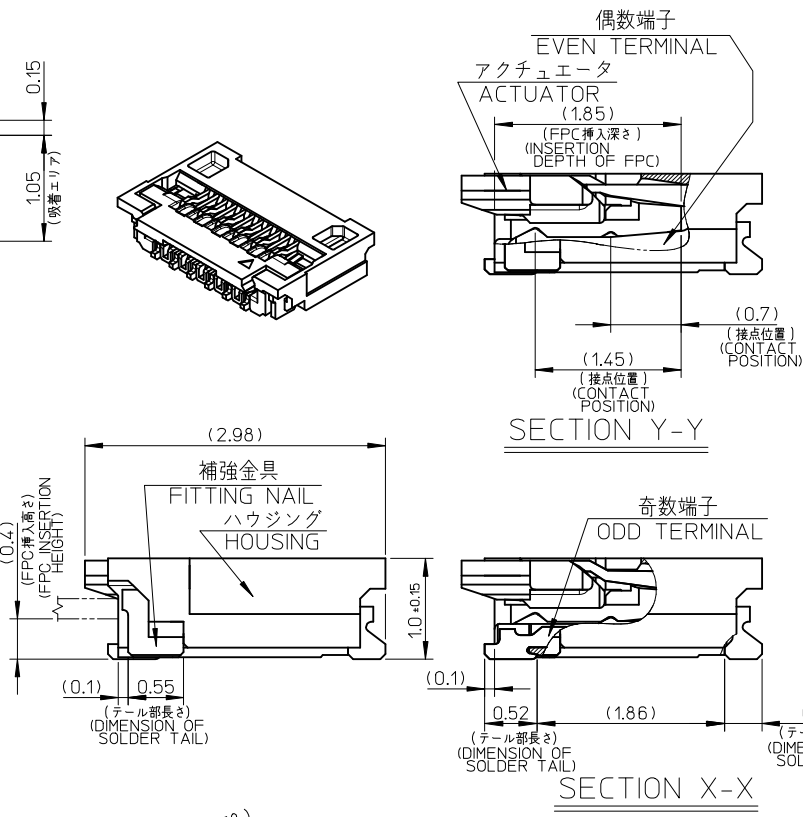
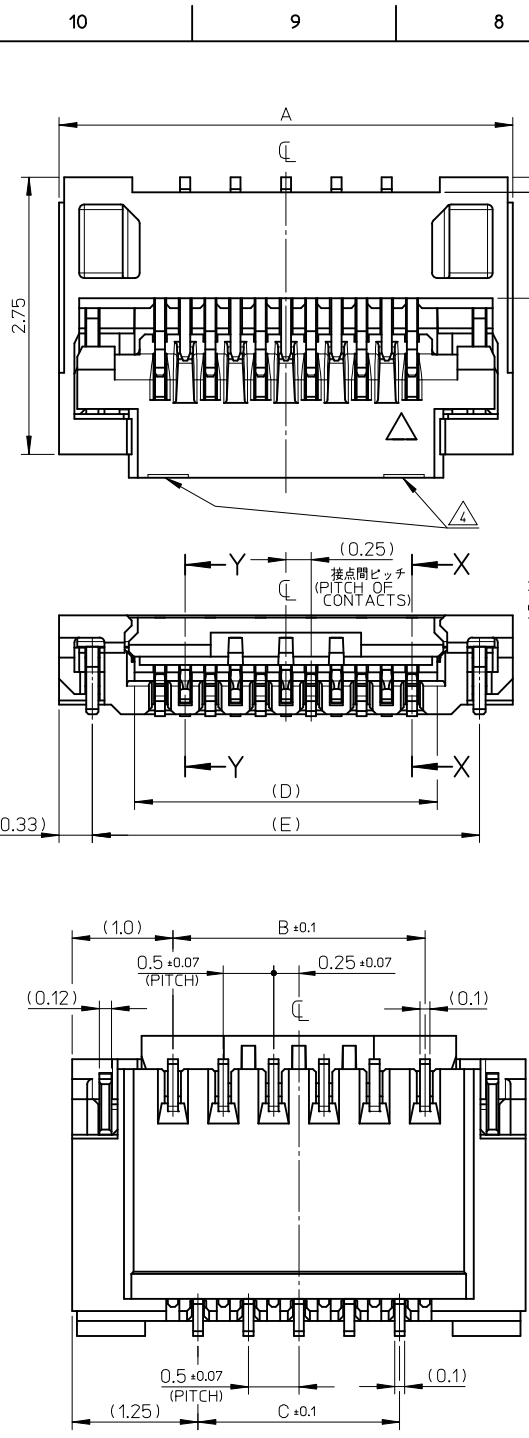

注記 NOTES

1. 使用材料 MATERIALS
 ハウジング : 液晶ポリマー (UL94V-0、ベージュ)
 アクチュエータ : ポリアミド (UL94HB、黒色)
 端子 : リン青銅
 補強金具 : リン青銅
 HOUSING : LCP (BEIGE)
 ACTUATOR : PA (BLACK)
 TERMINAL : PHOSPHOR BRONZE
 FITTING NAIL : PHOSPHOR BRONZE
2. メッキ仕様 PLATING
 端子 TERMINAL
 接点部 : 金メッキ0.14μm以上
 下地 : ニッケルメッキ1.0μm以上
 CONTACT AREA : Gold PLATING 0.14μm MINIMUM
 UNDER PLATING : Nickel PLATING 1.0μm MINIMUM
 金具 FITTING NAIL
 表面 : スズメッキ 0.5μm以上
 下地 : ニッケルメッキ1.0μm以上
 ALL OVER : Tin PLATING 0.5μm MINIMUM
 UNDER PLATING : Nickel PLATING 1.0μm MINIMUM
3. 端子、補強金具のコプラナリティーは 0.1 以下とする
 COPLANALITY OF SOLDER TAILS AND FITTING NAILS : 0.1MAX.
4. 一般公差 : ± 0.3
 GENERAL TOLERANCES : ± 0.3
- △ アクチュエータの図示箇所にゲート逃げの凹みがかかります
 THERE ARE DENT SHAPES AT ACTUATOR FOR MOLDING GATE
5. ELV & RoHS 適合品
 ELV & RoHS COMPLIANT
6. 塩素系・臭素系難燃剤非使用
 CHLORINATED AND BROMINATED FLAME RETARDANTS FREE

16.34	15.5	14.5	15	17	502078-6160	502078-6168	61
10.84	10	9	9.5	11.5	502078-3960	502078-3968	39
10.34	9.5	8.5	9	11	502078-3760	502078-3768	37
E	D	C	B	A	ORDER NO.	MATERIAL NO.	CKT. =N
						502078-**68	MODEL NO.

REVISED EC NO: J2010-0687 DRWN: YFUJITA 2009/10/05 CHKD: SHOSHIKAWA 2009/10/05 APPR: SHOSHIKAWA 2009/10/05	DESCRIPTION REV	GENERAL TOLERANCES (UNLESS SPECIFIED)		DIMENSION STYLE MM ONLY	SCALE 20:1	DESIGN UNITS METRIC	THIRD ANGLE PROJECTION	
		10 UNDER	± ---	DRAWN BY YFUJITA	DATE 2009/08/07	TITLE 0.25 PITCH FPC CONN E/O HGT=1.0 BTM CONTACT TYPE		
		10 OVER 30 UNDER	± ---	CHECKED BY SHOSHIKAWA	DATE 2009/08/07	MATERIAL NO. SD-502078-005		
		30 OVER	± ---	APPROVED BY AHORINO	DATE 2009/08/07	SHEET NO. 1 OF 2		
ANGULAR ±1 °		DRAFT WHERE APPLICABLE MUST REMAIN WITHIN DIMENSIONS		SEE CHART		DOCUMENT NO.		
				SIZE A3	THIS DRAWING CONTAINS INFORMATION THAT IS PROPRIETARY TO MOLEX INCORPORATED AND SHOULD NOT BE USED WITHOUT WRITTEN PERMISSION			

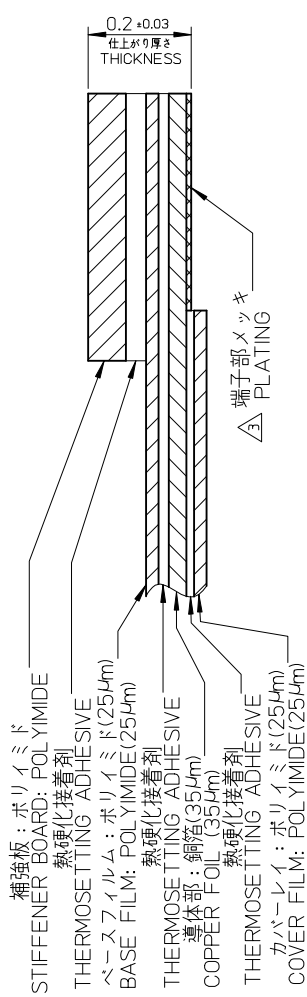

FPC 構成材料例
EXAMPLE OF FPC COMPOSITION MATERIAL

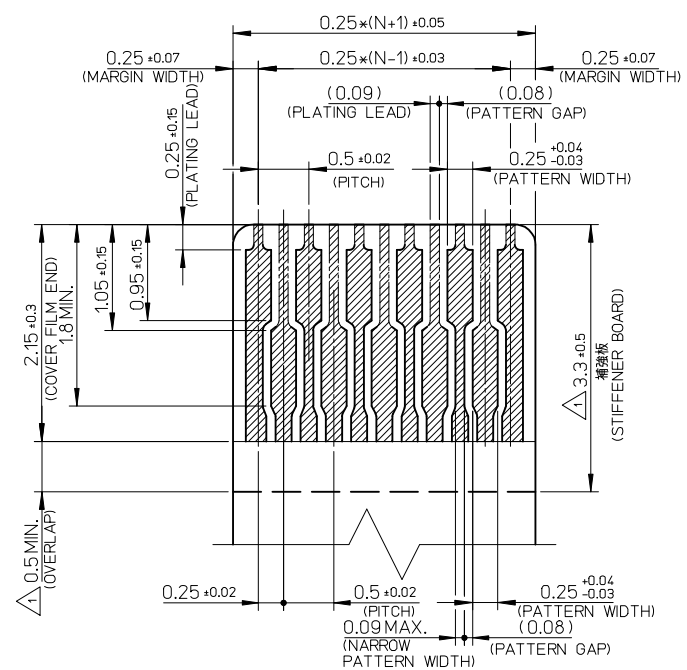

適合するFPC 推奨寸法
APPLICABLE FPC RECOMMENDED DIMENSION
(端子部仕上がり厚さ: 0.2±0.03)
(THICKNESS: 0.2±0.03)

注記 NOTES

- △ 補強板長さが図面通り確保できない場合は、カバーレイと補強板のオーバーラップ寸法を 0.5mm 以上としてください
WHEN STIFFENER BOARD DIMENSION CAN NOT BE SECURED AS DRAWING, PLEASE GIVE THE OVERLAP SIZE OF COVER FILM AND STIFFENER BOARD AS 0.5mm MINIMUM
- 2 推奨ペースト厚 : 100μm
推奨マスク開口率 : 80%
RECOMMEND SCREEN THICKNESS : 100μm
RECOMMEND SCREEN OPEN RATIO : 80%

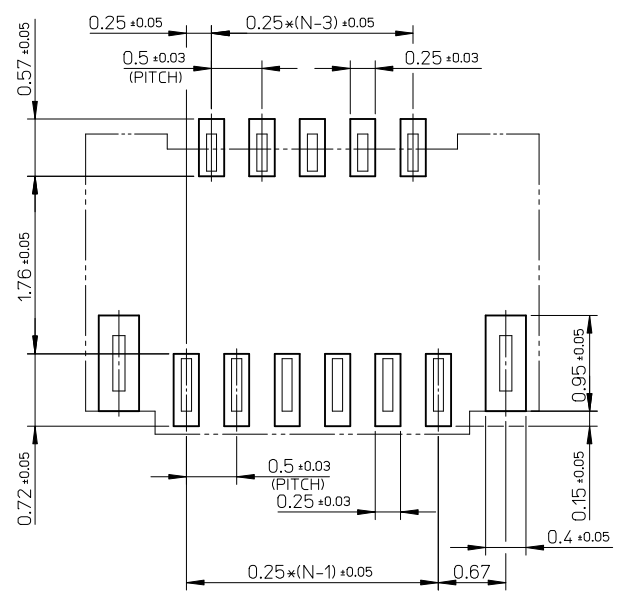

FPC 挿入側
FPC INSERTION SIDE
参考基板レイアウト
RECOMMENDED PCB PATTERN DIMENSIONS (REF.)

4 FPCについて (ABOUT FPC)
抜き方向は、導体側から補強板側を推奨します
補強板材質は、ポリイミドを推奨します
接着剤は熱硬化接着剤を推奨します
なお、接着剤の接点部への付着は導通不良の原因となりますので染み出しがないよう、お願いします
RECOMMENDED PUNCHER DIRECTION: FROM CONDUCTOR SIDE TO STIFFENER BOARD SIDE
RECOMMENDED MATERIAL: STIFFENER BOARD: POLYIMIDE
BONDING AGENT: THERMOSETTING AGENT
PLEASE PUT APPROPRIATE AMOUNT OF ADHESIVE ON THE CONTACT AREA BECAUSE THE EXTRA ADHESIVE MAY CAUSE THE DEFECT IN ELECTRICAL CONTINUITY

REVISED EC NO.: J2010-0687 DRWN: YFUJITA 2009/10/05 CHKD: SHOSHIKAWA 2009/10/05 APPR: SHOSHIKAWA 2009/10/05	DESCRIPTION REV	GENERAL TOLERANCES (UNLESS SPECIFIED)		DIMENSION STYLE MM ONLY	SCALE 20:1	DESIGN UNITS METRIC	THIRD ANGLE PROJECTION	
		10 UNDER	± ---	DRAWN BY YFUJITA	DATE 2009/08/07	TITLE 0.25 PITCH FPC CONN E/O HGT=1.0 BTM CONTACT TYPE		
		10 OVER 30 UNDER	± ---	CHECKED BY SHOSHIKAWA	DATE 2009/08/07	MOLEX MOLEX INCORPORATED		
		30 OVER	± ---	APPROVED BY AHORINO	DATE 2009/08/07			
ANGULAR ±1 ° DRAFT WHERE APPLICABLE MUST REMAIN WITHIN DIMENSIONS		MATERIAL NO. SEE SHEET 1 OF 2	DOCUMENT NO. SD-502078-005	SHEET NO. 2 OF 2				

注記 NOTES

- 製品詳細寸法については図面 SD-502078-005 を参照下さい。
RE DETAILED DIMENSION, SEE SD-502078-005
- 梱包数量：3000 個/リール
NUMBER OF CONNECTORS : 3000 PCS/REEL
- リードテープ長さ LEAD TAPE LENGTH

引き出し方向
PULL OUT
DIRECTION

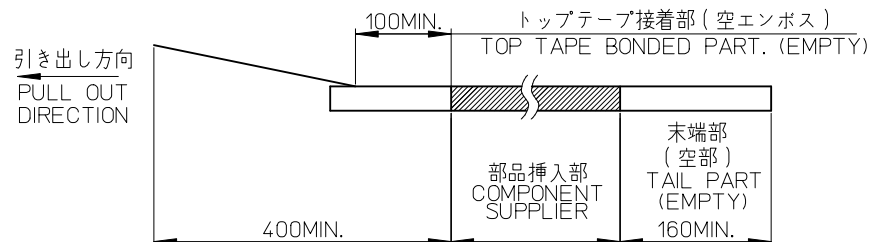
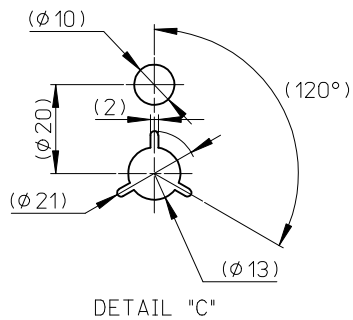
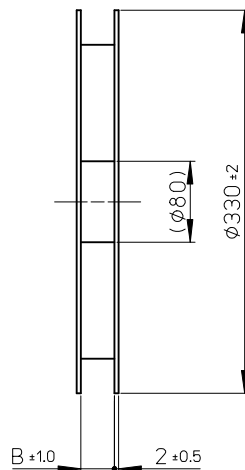
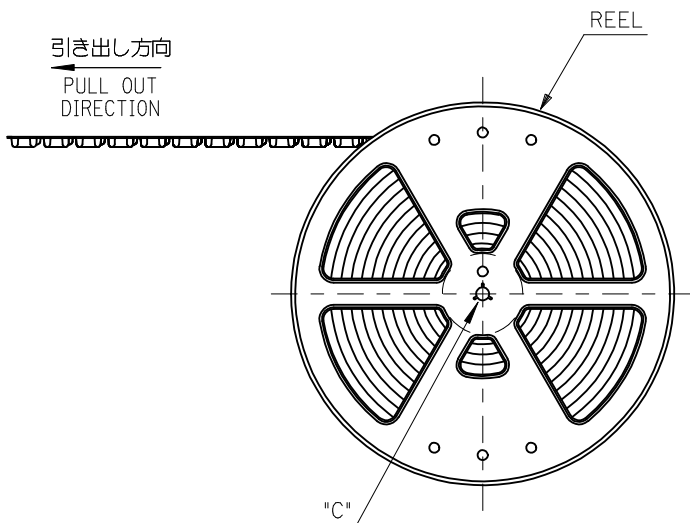

4. 材料 MATERIAL

キャリアテープ (CARRIER TAPE) : ポリスチレン (POLYSTYRENE)
 トップテープ (TOP TAPE) : PET , PE , PEF
 リール (REEL) : ポリスチレン (PS) <リサイクル材を含む>
 POLYSTYRENE (PS) <RECYCLE MATERIAL CONTAINED>

MODEL NO. 502078-**60

REVISED EC NO: J2010-0687 DRWN: YFUJITA 2009/10/05 CHKD: SHOSHIKAWA 2009/10/05 APPR: SHOSHIKAWA 2009/10/05	DESCRIPTION REV	GENERAL TOLERANCES (UNLESS SPECIFIED)		DIMENSION STYLE MM ONLY	SCALE 1:1	DESIGN UNITS METRIC	THIRD ANGLE PROJECTION	
		10 UNDER	± ---	DRAWN BY YFUJITA	DATE 2009/08/07	TITLE 0.25MM PITCH FPC CONN HGT=1.0 HSG ASSY EMBOSSED TAPE PACKAGE		
		10 OVER 30 UNDER	± ---	CHECKED BY SHOSHIKAWA	DATE 2009/08/07	MOLEX INCORPORATED		
		30 OVER	± ---	APPROVED BY AHORINO	DATE 2009/08/07	MATERIAL NO. SEE CHART	DOCUMENT NO. SD-502078-006	SHEET NO. 1 OF 3
		ANGULAR ±1 ° DRAFT WHERE APPLICABLE MUST REMAIN WITHIN DIMENSIONS		SIZE A3	THIS DRAWING CONTAINS INFORMATION THAT IS PROPRIETARY TO MOLEX INCORPORATED AND SHOULD NOT BE USED WITHOUT WRITTEN PERMISSION			

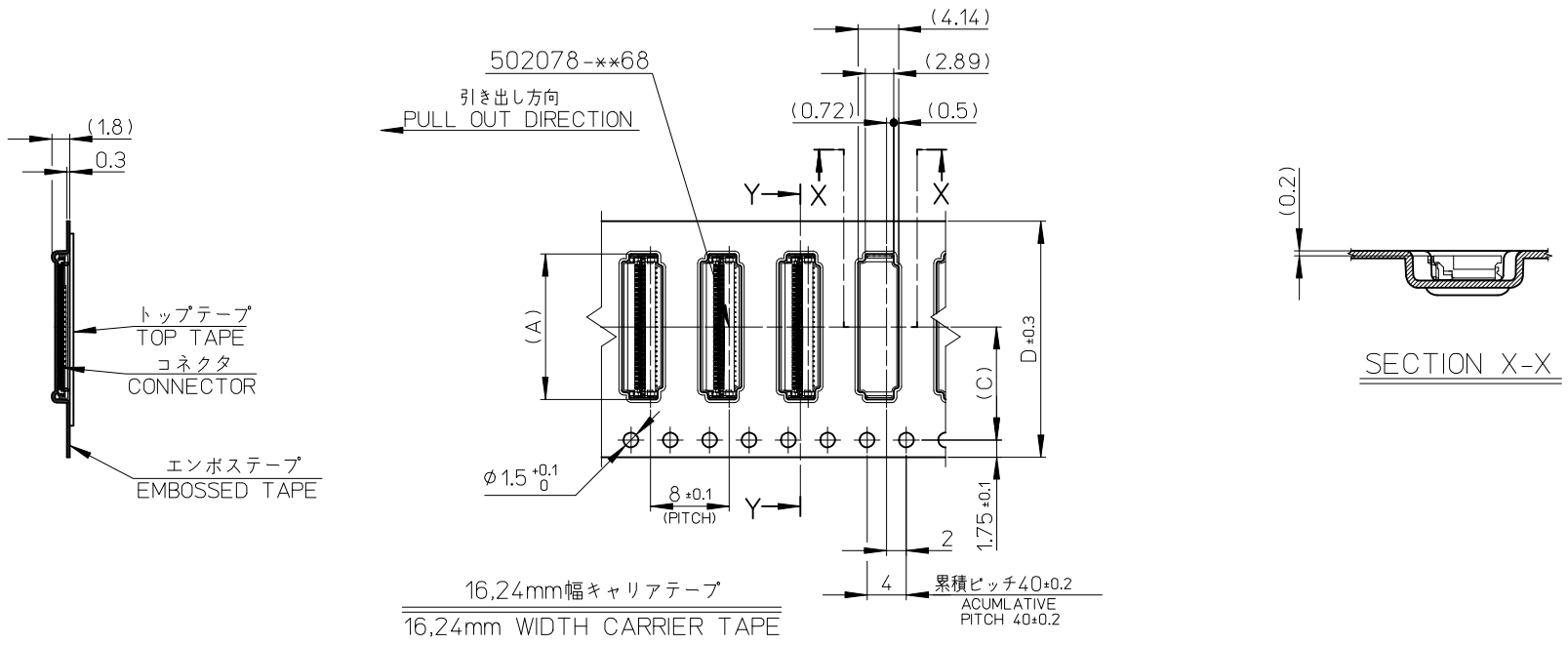

16,24mm幅キャリアテープ
16,24mm WIDTH CARRIER TAPE

累積ピッチ40±0.2
ACUMULATIVE PITCH 40±0.2

24	11.5	25.4	11.8	502078-3960	39
			11.3	502078-3760	37
D キャリアテープ幅 CARRIER TAPE WIDTH	C	B	(A)	製品番号 MATERIAL NO.	極数 CKT.
MODEL NO.				502078-**-60	

REVISED EC NO: J2010-0687 DRWN: YFUJITA CHK'D: SHOSHIKAWA APPR: SHOSHIKAWA	2009/10/05 2009/10/05 2009/10/05	GENERAL TOLERANCES (UNLESS SPECIFIED)		DIMENSION STYLE		SCALE		DESIGN UNITS		THIRD ANGLE PROJECTION		
		10 UNDER		± ---	MM ONLY		1:1		METRIC		◎ THIR ANGLE PROJ ECTION	
		10 OVER 30 UNDER		± ---	DRAWN BY		DATE		TITLE		0.25MM PITCH FPC CONN HGT=1.0 HSG ASSY EMBOSSED TAPE PACKAGE MOLEX INCORPORATED	
		30 OVER		± ---	YFUJITA		2009/08/07					
ANGULAR		±1 °	CHECKED BY		DATE		DOCUMENT NO.		SHEET NO.			
DRAFT WHERE APPLICABLE MUST REMAIN WITHIN DIMENSIONS			SHOSHIKAWA		2009/08/07		SD-502078-006		2 OF 3			
			APPROVED BY		DATE		SEE CHART					
			AHORINO		2009/08/07		THIS DRAWING CONTAINS INFORMATION THAT IS PROPRIETARY TO MOLEX INCORPORATED AND SHOULD NOT BE USED WITHOUT WRITTEN PERMISSION					
			MATERIAL NO.									

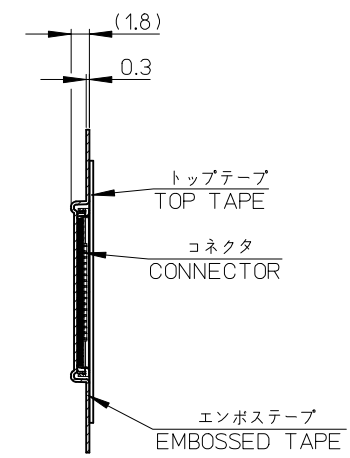

SECTION Y-Y

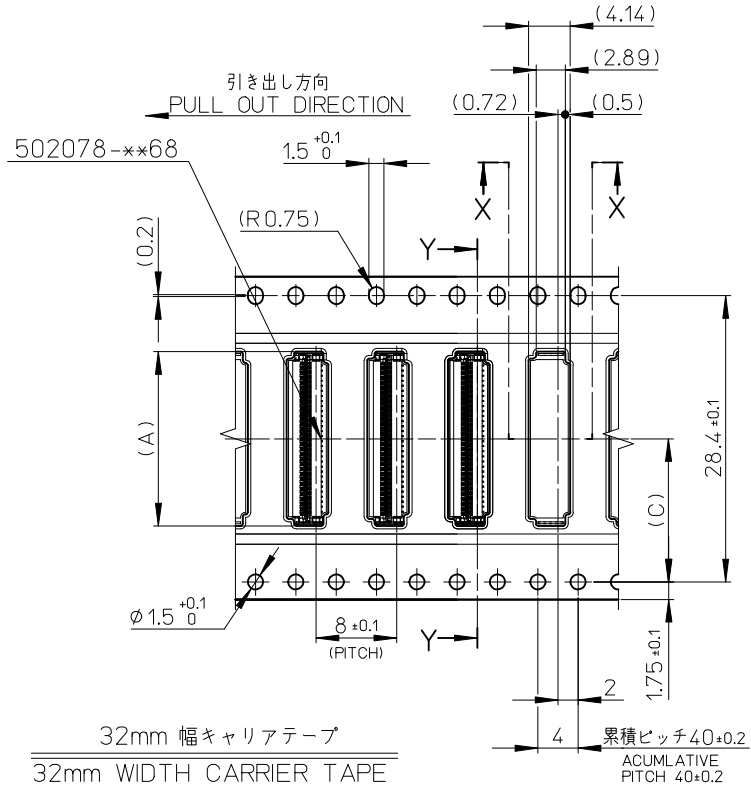

32mm 幅キャリアテープ
32mm WIDTH CARRIER TAPE

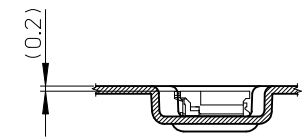

SECTION X-X

14.2	33.4	17.3	502078-6160	61
C	B	(A)	製品番号 MATERIAL NO.	極数 CKT.
MODEL NO.			502078-60	

REVISED EC NO: J2010-0687 DRWN: YFUJITA 2009/10/05 CHKD: SHOSHIKAWA 2009/10/05 APPR: SHOSHIKAWA 2009/10/05	DESCRIPTION REV	GENERAL TOLERANCES (UNLESS SPECIFIED)		DIMENSION STYLE MM ONLY		SCALE 1:1	DESIGN UNITS METRIC	THIRD ANGLE PROJECTION		
		10 UNDER	± ---	DRAWN BY YFUJITA	DATE 2009/08/07	TITLE 0.25MM PITCH FPC CONN HGT=1.0 HSG ASSY EMBOSSSED TAPE PACKAGE				
		10 OVER 30 UNDER	± ---	CHECKED BY SHOSHIKAWA	DATE 2009/08/07	MOLEX INCORPORATED				
		30 OVER	± ---	APPROVED BY AHORINO	DATE 2009/08/07	DOCUMENT NO. SD-502078-006				
ANGULAR ±1 °		DRAFT WHERE APPLICABLE MUST REMAIN WITHIN DIMENSIONS		MATERIAL NO. SEE CHART		SHEET NO. 3 OF 3				
SIZE A3		THIS DRAWING CONTAINS INFORMATION THAT IS PROPRIETARY TO MOLEX INCORPORATED AND SHOULD NOT BE USED WITHOUT WRITTEN PERMISSION								