

250 Watt AC-DC Converters with PFC

KP Series

Input voltage from 187...255 V AC
1 or 2 isolated outputs up to 56.5 V DC
4 kV AC I/O electric strength test voltage

- Power factor >0.95, harmonics <IEC/EN61000-3-2
- Output power up to 280 Watt
- Input over- and undervoltage lock-out
- Efficient input filter and built-in surge and transient suppression circuitry
- Fully isolated outputs
- Outputs open- and short-circuit proof

Safety according to IEC/EN 60950

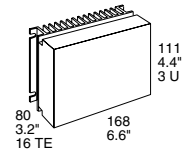

Summary

The KP series is an extension of the K series of AC-DC converters with an increased output power level of up to 280 W depending on the operating ambient temperature requirements. The KP converters are optimized for use in 230 V AC mains applications and feature high efficiency, high reliability, low output voltage noise and excellent dynamic response to load/line changes.

The converter inputs are protected against surges and transients occurring at the source lines. An input over- and undervoltage lock-out circuitry disables the outputs if the input voltage is outside the specified range. The LKP types include an inrush current limitation preventing circuit breakers and fuses from being damaged at switch-on.

The outputs are open- and short-circuit proof and are protected against overvoltages by means of a built-in suppressor diode. The outputs can be inhibited by a logic signal applied to the connector pin 18 (i). If the inhibit function is not used pin 18 must be connected with pin 14 to enable the outputs (fail safe).

LED indicators display the status of the converter and allow visual monitoring of the system at any time.

Full input to output, input to case, output to case and output to output isolation is provided. The modules are designed and built according to the international safety standards IEC/EN 60950.

The case design allows operation up to an operating ambient temperature of 71 °C with reduced output power. Depending on the ambient temperature requirements, however, the output power can be up to 280 W.

An internal temperature sensor generates an inhibit signal which disables the outputs if the case temperature T_C exceeds the specified limit. The outputs are automatically re-enabled when the temperature drops below the limit.

Various options are available to adapt the converters to individual applications. Especially for battery charger applications an external temperature sensor has been designed to allow for temperature compensated battery charging.

The modules may either be plugged into 19" rack systems according to DIN 41494 or be chassis mounted.

Table of Contents

Table of Contents	Page	Page	
Summary	1	Electromagnetic Compatibility (EMC)	14
Type Survey and Key Data	2	Immunity to Environmental Conditions	15
Type Key	2	Mechanical Data	16
Functional Description	3	Safety and Installation Instructions	17
Electrical Input Data	4	Description of Options	20
Electrical Output Data	6	Accessories	23
Auxiliary Functions	10		

Type Survey and Key Data

Non standard input/output configurations or special custom adaptations are available on request. See also: *Commercial Information: Inquiry Form for Customized Power Supply*.

Table 1: Type survey

Output voltage U_o [V DC]	Output current ,input voltage and efficiency ¹									Opt.
	$T_A = 50^\circ\text{C}$ $I_{o\text{ nom}}$ [A]	$U_{i\text{ min}} \dots U_{i\text{ max}}$ 187...255 V AC	η_{min} [%]	$T_A = 60^\circ\text{C}$ $I_{o\text{ nom}}$ [A]	$U_{i\text{ min}} \dots U_{i\text{ max}}$ 187...255 V AC	η_{min} [%]	$T_A = 71^\circ\text{C}$ $I_{o\text{ nom}}$ [A]	$U_{i\text{ min}} \dots U_{i\text{ max}}$ 187...255 V AC	η_{min} [%]	
24 ²	11.6	LKP 5661-5R	85	10.4	LKP 5660-6R	86	9.6	LKP 5662-7R	85	E D P ⁵ T B1
25.25...28.25 ²	10	LKP 5741-5R ⁴	85	9	LKP 5740-6R ⁴	86	8	LKP 5742-7R ⁴	85	
24, 24	5.8, 5.8	LKP 5661-5R	85	5.2, 5.2	LKP 5660-6R	86	4.8, 4.8	LKP 5662-7R	85	
48 ³	5.8	LKP 5661-5R	85	5.2	LKP 5660-6R	86	4.8	LKP 5662-7R	85	
50.5...56.5 ³	5	LKP 5741-5R ⁴	85	4.5	LKP 5740-6R ⁴	86	4	LKP 5742-7R ⁴	85	

¹ Efficiency at $U_{i\text{ nom}}$ and $I_{o\text{ nom}}$.

² Parallel connection of U_{o1} and U_{o2} .

³ Series connection of U_{o1} and U_{o2} .

⁴ Designed for battery charging. Needs external temperature sensor.

⁵ Option P not available for LKP 5741-5R, LKP 5740-6R, LKP 5742-7R.

Type Key

Type Key

Input voltage range U_i :

187...255 V AC, 47...63 Hz L

Series KP

Number of outputs (5 for double outputs) 5

Nominal voltage output 1

Rectifier version 6

Battery charger version 7

Other specifications 0...9

Symmetrical double output units:

Nominal voltage output 1/output 2, $U_{o1/2\text{ nom}}$

24 V/24 V (48 V series connection) 60¹

25.25...28.25 V (50.5...56.5 V ser. conn.) 40¹

other symmetrical voltages 80...99

Operational ambient temperature range T_A :

-25...50°C -5

-25...60°C -6

-25...71°C -7

Customer specific -0...-4

Auxiliary functions and options:

Output voltage control input R²

Inrush current limitation E

Potentiometer (output voltage adjustment) P²

Save data signal (D0...DD, to be specified) ... D

Current sharing T

Cooling plate B1

L KP 5 6 60 -6 E R P D T B1

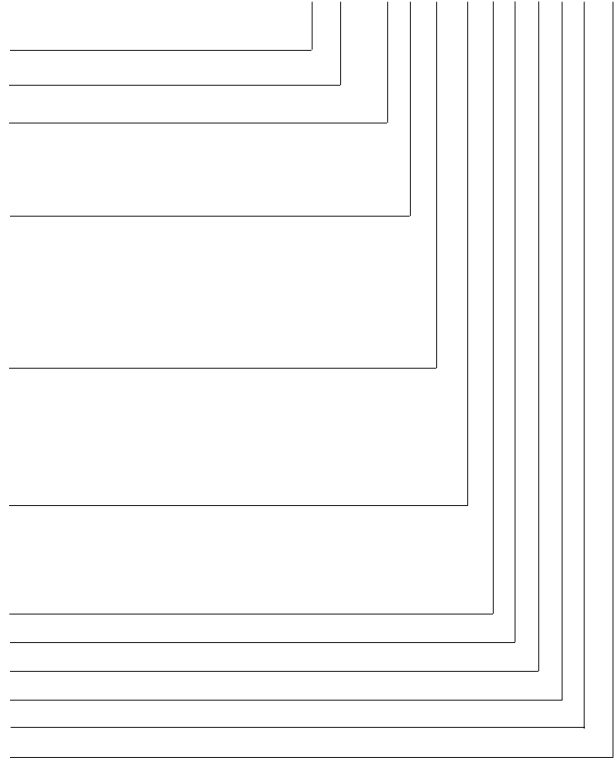

¹ External wiring of main and second output depending upon the desired output configuration (see: *R-Function for different output configurations*).

² Feature R excludes option P and vice versa. Option P not available for LKP 5740-6R.

Example: LKP 5740-6RD3: Power factor corrected AC-DC converter, input voltage range 187...255 V AC, double output, each providing 25.25...28.25 V/4.5 A, equipped with feature R, undervoltage monitoring option, operational ambient temperature range -25...60°C.

Functional Description

The input voltage is fed via an input fuse, an input filter, a rectifier and an inrush current limiter to a single transistor boost converter. This converter provides a sinusoidal input current (IEC/EN 61000-3-2, class D equipment) and sources a capacitor with a voltage of 360-370 VDC. This capacitor sources a single transistor forward converter.

Each output is powered by a separate secondary winding on the main transformer. The resultant voltages are rectified and their ripples smoothed by a power choke and an

output filter. The control logic senses the main output voltage U_{o1} and generates, with respect to the maximum admissible output currents, the control signal for the primary switching transistor.

The second output is controlled by the main output but has independent current limiting. If the main output is driven into current limitation, the second output voltage will fall as well and vice versa.

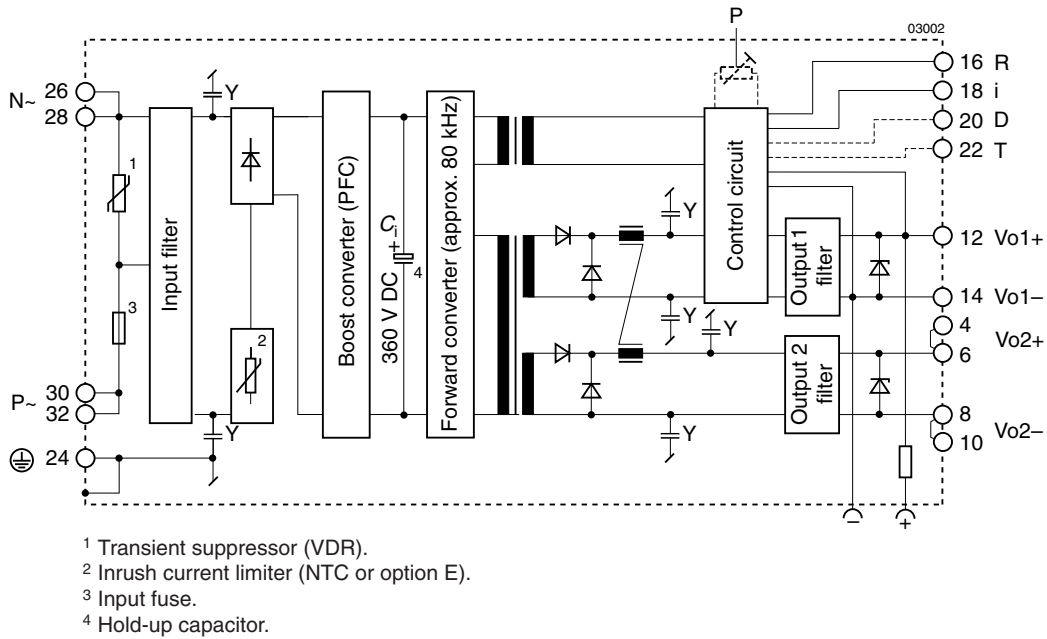

Fig. 1
 Block diagram of symmetrical double output converters LKP 5000

Electrical Input Data

General Conditions

- $T_A = 25^\circ\text{C}$, unless T_C is specified.
- Pin 18 connected to pin 14, U_o adjusted to $U_{o\text{ nom}}$ (option P); R input not connected.

Table 2: Input data

Input Characteristics		Conditions	LKP			Unit
			min	typ	max	
U_i	Operating input voltage	$I_o = 0 \dots I_{o\text{ nom}}$	187		255	V AC ³
$U_{i\text{ nom}}$	Nominal input voltage	$T_C\text{ min} \dots T_C\text{ max}$		230		
I_i	Input current	$U_{i\text{ nom}}, I_{o\text{ nom}}^1$		1.25		A_{rms}
$P_{i\text{ o}}$	No-load input power	$U_{i\text{ min}} \dots U_{i\text{ max}}$		7	10	W
$P_{i\text{ inh}}$	Idle input power	unit inhibited		2	3	
R_i	Input resistance	$T_C = 25^\circ\text{C}$	480			m Ω
R_{NTC}	NTC resistance ²		3200	4000		
C_i	Input capacitance		52.8	66	79.2	
$U_{i\text{ RFI}}$	Conducted input RFI	EN 55022	B			
	Radiated input RFI	$U_{i\text{ nom}}, I_{o\text{ nom}}$	B			
$U_{i\text{ abs}}$	Input voltage limits (without damage)		-400		400	V DC
			-400		400	V _P

¹ With double output modules, both outputs loaded with $I_{o\text{ nom}}$.

² Initial switch-on cycle. Subsequent switch-on/off cycles increase the inrush current peak value.

³ AC frequency range 47...63 Hz.

Input Fuse

A fuse mounted inside the converter protects the module against severe defects.

Table 3: Fuse Specification

Module	Fuse type	Fuse rating
LKP 5000 ¹	slow-blow	SP T 4 A, 250 V

¹ Fuse size 5 × 20 mm

Input Under-/Overvoltage Lock-out

If the input voltage remains below approx. 110 V AC or exceeds approx. 280 V AC an internally generated inhibit signal disables the output(s). When checking this function the absolute maximum input voltage rating $U_{i\text{ abs}}$ should be considered! Between $U_{i\text{ min}}$ and the undervoltage lock-out level the output voltage may be below the value defined in table: *Output data* (see: *Technical Information: Measuring and Testing*).

Input Transient Protection

A VDR together with the input fuse and a symmetrical input filter form an effective protection against high input transient voltages.

Inrush Current Limitation

The modules of the versions -5, -6, -7 incorporate an NTC resistor in the input circuitry which - at initial turn on - reduces the peak inrush current value by a factor of 5...10 to protect connectors and switching devices from damage. Subsequent switch-on cycles within short periods will cause an increase of the peak inrush current value due to the warming-up of the NTC resistor. See also: *E option*.

Inrush Current Peak Value

The inrush current peak value (initial switch-on cycle) can be determined by following calculation:

$$I_{\text{inr p}} = \frac{U_{i\text{ rms}} \cdot \sqrt{2}}{(R_{s\text{ ext}} + R_i + R_{\text{NTC}})}$$

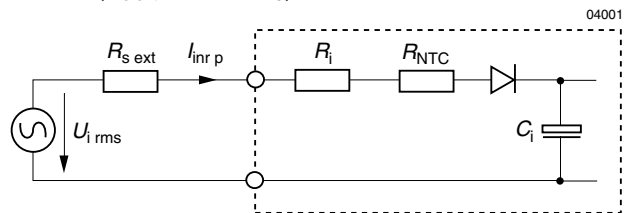

Fig. 2
Equivalent circuit diagram for input impedance

Input Inrush Current Characteristic

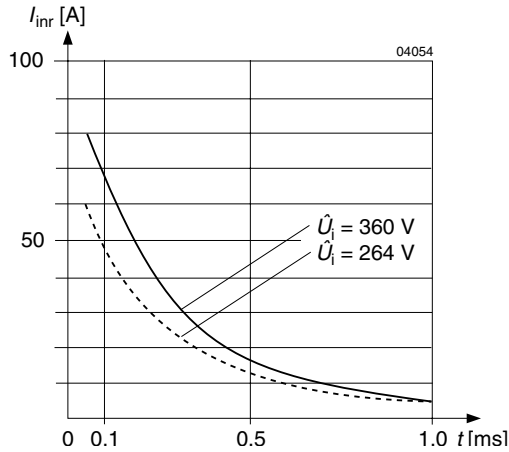

Fig. 3
Theoretical input inrush current versus time at $\hat{U}_i = 187 \text{ V} \cdot \sqrt{2}$ (264 V) and $255 \text{ V} \cdot \sqrt{2}$ (360 V), $R_{\text{ext}} = 0$

Static Input current Characteristic

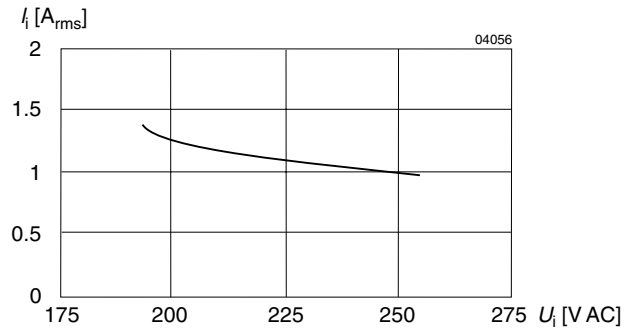

Fig. 5
Input current versus input voltage at $I_o \text{ nom}$

Power Factor, Harmonics

Power factor correction is achieved by controlling the input current waveform synchronously with the input voltage waveform. The power factor control is active under all operating conditions.

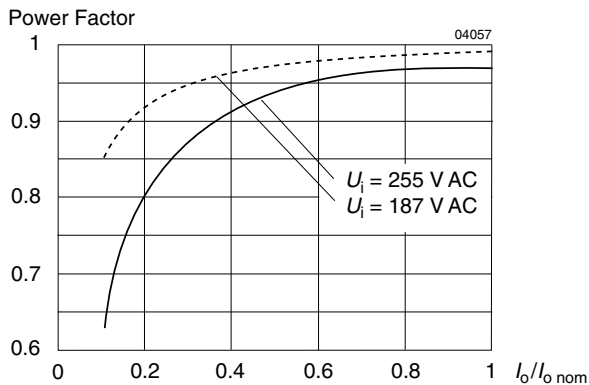

Fig. 4
Power factor versus output power at U_i 255 V AC and 187 V AC.

Harmonic Currents

The harmonic distortion is well below the limits specified in IEC/EN 61000-3-2, class D.

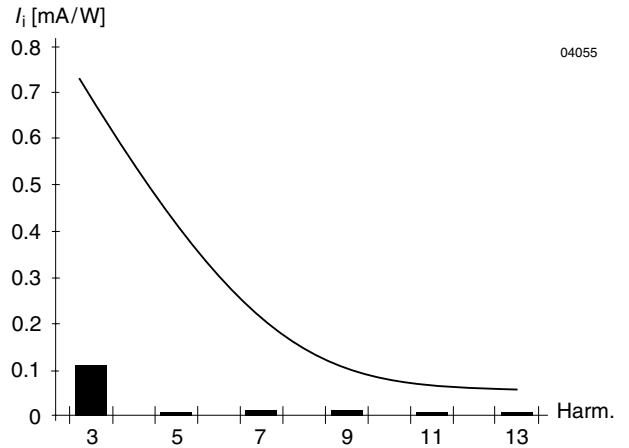

Fig. 6
Harmonic currents at the input, IEC/EN 61000-3-2, class D. $U_i = U_i \text{ nom}$, $I_o = I_o \text{ nom}$.

Electrical Output Data

General Conditions

- $T_A = 25^\circ\text{C}$, unless T_C is specified.
- Pin 18 (i) connected to pin 14 (S–/Vo1–), U_o adjusted to $U_{o\text{ nom}}$ (option P), R input not connected.

Table 4a: Output data double output modules

Output (Outputs connected in Series)			LKP 5660-6 48 V (2 × 24 V)			LKP 5740-6 51.36 V (2 × 25.68 V)			Unit
Characteristics		Conditions	min	typ	max	min	typ	max	
U_o	Output voltage ²	$U_{i\text{ nom}}, I_{o\text{ nom}}$	48.0			51.36			V
$U_{o\text{ max}}$	Maximum output voltage for battery charging					56.5			
$U_{o\text{ P}}$	Overvoltage protection		82			82			
$I_{o\text{ nom}}$	Output current ¹	$U_{i\text{ min}} \dots U_{i\text{ max}}$ $T_C\text{ min} \dots T_C\text{ max}$	5.2			4.5			A
$I_{o\text{ L}}$	Output current limit ⁴	$U_{i\text{ min}} \dots U_{i\text{ max}}$	5.3			4.6			
u_o ⁷	Output voltage noise ³	Low frequency	$U_{i\text{ nom}}, I_{o\text{ nom}}$			15			mV _{pp}
		Switching freq.	IEC/EN 61204 BW = 20 MHz			30			
		Total				180			
$\Delta U_{o\text{ U}}$	Static line regulation	$U_{i\text{ min}} \dots U_{i\text{ nom}}$ $U_{i\text{ nom}} \dots U_{i\text{ max}}$ $I_{o\text{ nom}}$	± 20			± 20			mV
$\Delta U_{o\text{ I}}$	Static load regulation	$U_{i\text{ nom}}, I_o =$ $(0.1 \dots 1) I_{o\text{ nom}}$	100			100			
$u_{o\text{ d}}$ ⁵	Dynamic load regulation	Voltage deviation	$U_{i\text{ nom}}$ $I_{o\text{ nom}} \leftrightarrow 1/2 I_{o\text{ nom}}$			± 200			ms
t_d ⁵		Recovery time	IEC/EN 61204			0.3			
α_{U_o}	Temperature coefficient of output voltage ⁶	$T_C\text{ min} \dots T_C\text{ max}$ $0 \dots I_{o\text{ nom}}$	–2.6			–2.6			mV/K

¹ If the output voltages are increased above $U_{o\text{ nom}}$ through R-input control, option P setting, remote sensing or option T, the output currents should be reduced accordingly so that $P_{o\text{ nom}}$ is not exceeded.

² Series connection for $U_{o\text{ nom}} = 48\text{ V}$ or 51.35 V , see: *R-Function for different output configurations*. Factory adjusted with open R-input.

³ Shortest possible wiring for series connection at the connector.

⁴ See: *Typical Output Voltage Regulation of Single or Double Output Modules with Outputs 1 and 2 Connected in Series*.

⁵ See: *Typical dynamic load regulation of U_{o1} and U_{o2}* .

⁶ Negative temperature coefficient ($0 \dots -3\text{ mV/cell and K}$) available on request.

⁷ Measured according to IEC/EN 61204 sub clause 3.10 with a probe acc. to annex A of the same standards. (See: *Technical Information: Measuring and Testing*.)

Table 4b: Output data double output modules

Output (Outputs independently loaded) ¹				LKP 5660-6 24 V/24 V			LKP 5740-6 25.68 V/25.68 V					
Characteristics		Conditions		Output 1		Output 2		Output 1		Output 2		Unit
				min	typ max	min	typ max	min	typ max	min	typ max	
U_o	Output voltage ²	$U_{i\ nom}, I_{o\ nom}$		23.86	24.14	23.64	24.36	25.53	25.83	25.29	26.06	V
$U_{o\ max}$	Maximum output voltage for battery charging								28.25		28.25	
$U_{o\ P}$	Overvoltage protection			41		41		41		41		
$I_{o\ nom}$	Output current ³	$U_{i\ min...} U_{i\ max}$ $T_C\ min... T_C\ max$		5.2		5.2		4.5		4.5		A
I_{oL}	Output current limit ⁴	$U_{i\ min...} U_{i\ max}$		5.3		5.3		4.6		4.6		
u_o ⁸	Output voltage noise	Low frequency	$U_{i\ nom}, I_{o\ nom}$	10		10		10		10		mV _{pp}
		Switching freq.	IEC/EN 61204 BW = 20 MHz	20		20		20		20		
		Total		150		40		150		40		
ΔU_{oU}	Static line regulation	$U_{i\ min...} U_{i\ nom}$ $U_{i\ nom...} U_{i\ max}$ $I_{o\ nom}$			±10		±10		±10		±10	mV
ΔU_{oI}	Static load regulation	$U_{i\ nom}, I_o =$ $(0.1...1) I_{o\ nom}$ ⁵			100		5		100		5	
$u_{o\ d}$ ⁶	Dynamic load regulation	Voltage deviation	$U_{i\ nom}$ $I_{o\ nom} \leftrightarrow 1/2 I_{o\ nom}$		±150				±150			
t_d ⁶		Recovery time	IEC/EN 61204		0.3				0.3			ms
α_{Uo}	Temperature coefficient of output voltage ⁷	$T_C\ min... T_C\ max$ $0... I_{o\ nom}$			-2.6				-2.6			mV/K

¹ Depending upon the desired output configuration the wiring should be made as shown in: *R-Function for different output configurations*.

² Same conditions for both outputs. Factory adjustment with open R-input.

³ If the output voltages are increased above $U_{o\ nom}$ via R-input control, option P setting, remote sensing or option T, the output currents should be reduced accordingly so that $P_{o\ nom}$ is not exceeded.

⁴ See: *Typical Output Voltage Regulation of Single or Double Output Modules with Outputs 1 and 2 Connected in Series*.

⁵ Condition for specified output. Other output loaded with constant current $I_o = I_{o\ nom}$. See fig.: *Output voltage regulation of double output units*.

⁶ See: *Typical dynamic load regulation of U_{o1} and U_{o2}* .

⁷ Negative temperature coefficient (0...-3 mV/cell and K) available on request.

⁸ Measured according to IEC/EN 61204 sub clause 3.10 with a probe acc. to annex A of the same standards. (see: *Technical Information: Measuring and Testing*)

Thermal Considerations

If a converter is located in free, quasi-stationary air (convection cooling) at the indicated maximum ambient temperature $T_{A\max}$ (see: table *Temperature specifications*) and is operated at its nominal input voltage and output power, the temperature measured at the *Measuring point of case temperature* T_C (see: *Mechanical Data*) will approach the indicated value $T_{C\max}$ after the warm-up phase. However, the relationship between T_A and T_C depends heavily on the conditions of operation and integration into a system. The thermal conditions are influenced by input voltage, output current, airflow and temperature of surrounding components and surfaces. $T_{A\max}$ is therefore, contrary to $T_{C\max}$, an indicative value only.

Caution: The installer must ensure that under all operating conditions T_C remains within the limits stated in the table: *Temperature specifications*.

Notes: Sufficient forced cooling or an additional heat sink allows T_A to be higher than 60°C (e.g. 70°C) if $T_{C\max}$ is not exceeded.

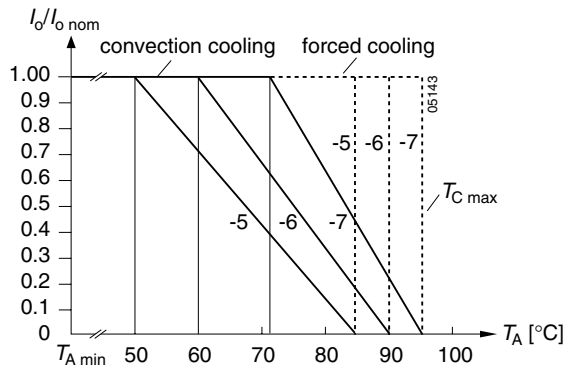

Fig. 7 Output current derating versus temperature for -5, -6 and -7 units.

Thermal Protection

A temperature sensor generates an internal inhibit signal which disables the outputs if the case temperature exceeds $T_{C\max}$. The outputs are automatically re-enabled if the temperature drops below this limit.

Output Protection

Each output is protected against overvoltage which could occur due to a failure of the control circuit by means of a voltage suppressor diode which, under worst case conditions, may become a short circuit. The suppressor diodes are not designed to withstand externally applied overvoltages. Overload at any of the two outputs will cause a shut-down of both outputs. A red LED indicates the overload condition.

Parallel or Series Connection of Units

Units with equal nominal output voltage can be connected in parallel without any precautions using option T.

With option T (current sharing), all units share the current approximately equally.

Main and second outputs can be connected in series with any other (similar) output.

Note:

- Parallel connection of double output units should always include both, main and second output to maintain good regulation of both outputs.
- Not more than 3 units should be connected in parallel.
- Series connection of second outputs without involving their main outputs should be avoided as regulation may be poor.
- The maximum output current is limited by the output with the lowest current limitation if several outputs are connected in series.

Efficiency versus Load

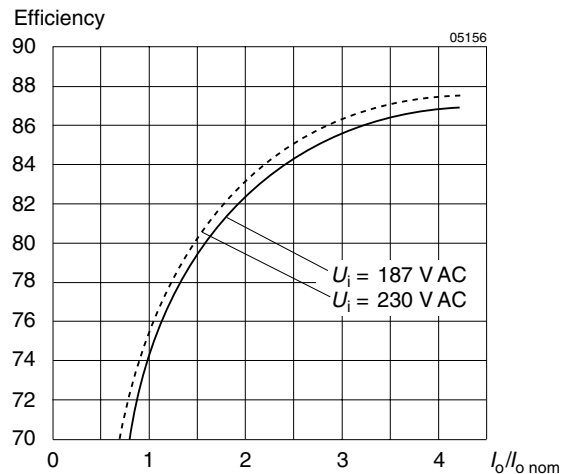

Fig. 8 Efficiency versus load at U_i 230 V AC and 187 V AC

Switching Frequency versus Load

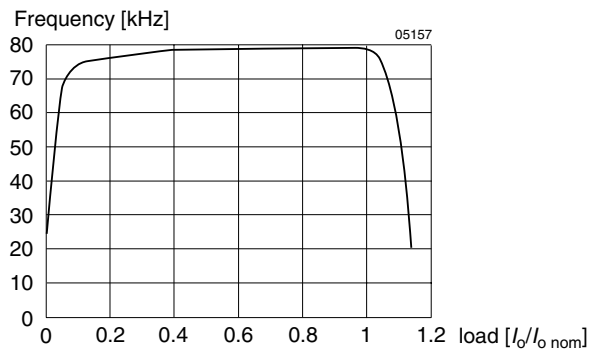

Fig. 9 Switching frequency versus load. (The boost converter at the input stage has a fixed frequency of 100 kHz)

Output Voltage Regulation

Output 1 is under normal conditions regulated to $U_{o1 \text{ nom}}$, independent of the output currents.

U_{o2} is dependent upon the load distribution. If both outputs are loaded with more than 10% of $I_{o \text{ nom}}$, the deviation of U_{o2} remains within $\pm 5\%$ of the value of U_{o1} . The following figure shows the regulation with varying load distribution. If $I_{o1} = I_{o2}$ or the two outputs are connected in series, the deviation of U_{o2} remains within $\pm 1\%$ of the value of U_{o1} provided that a total load of more than 10% of $I_{o \text{ nom}}$ is applied.

If both outputs of a single LKP 5000 module are connected in parallel the paralleled output is fully regulated. No precautions are necessary in using the R-input and the test sockets.

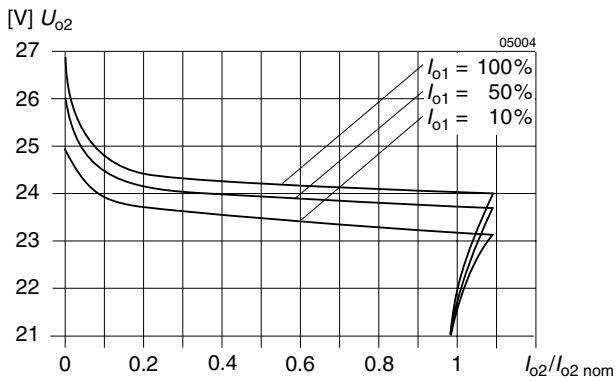

Fig. 10
LK 5660: ΔU_{o2} (typ.) versus I_{o2} with different I_{o1}

Output Voltage Regulation Connected in Series

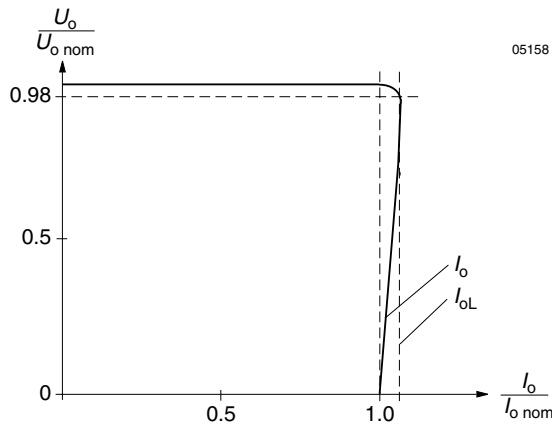

Fig. 11
 U_o versus I_o

Dynamic Load Regulation

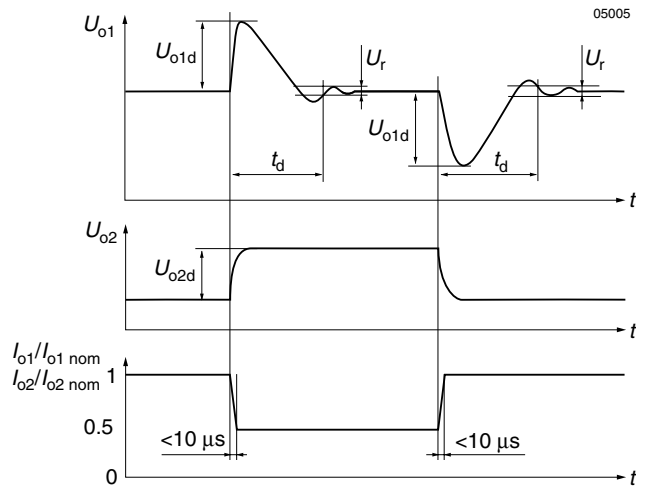

Fig. 12
Typical dynamic load regulation of U_{o1} and U_{o2} .

Hold-up Time versus Output Power

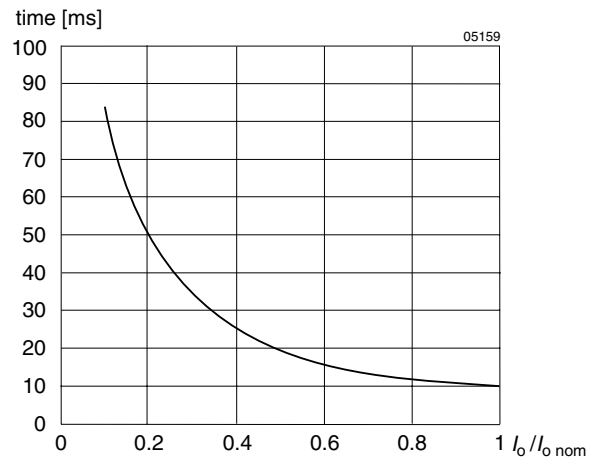

Fig. 13
Hold-up time t_h versus output power

Auxiliary Functions

i Inhibit for Remote On and Off

Note: With open i input: Output is disabled ($U_o = \text{off}$).

The outputs of the module may be enabled or disabled by means of a logic signal (TTL, CMOS, etc.) applied between the inhibit input i and the negative pin of output 1 (Vo1-). In systems with several units, this feature can be used, for example, to control the activation sequence of the converters. If the inhibit function is not required, connect the inhibit pin 18 to pin 14 to enable the outputs (active low logic, fail safe). For output response refer to: *Hold-up Time and Output Response*.

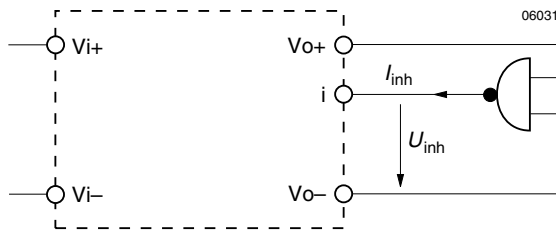

Fig. 14
Definition of U_{inh} and I_{inh} .

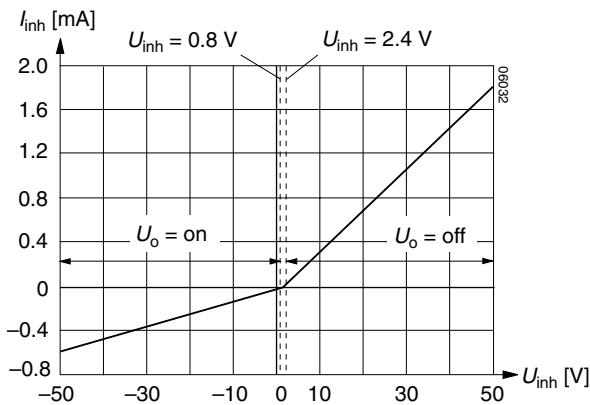

Fig. 15
Typical inhibit current I_{inh} versus inhibit voltage U_{inh}

Table 5: Inhibit characteristics

Characteristic	Conditions	min	typ	max	Unit
U_{inh} Inhibit voltage	$U_o = \text{on}$		-50	0.8	V
	$U_o = \text{off}$		2.4	50	
I_{inh} Inhibit current	$U_{inh} = 0$			-400	μA
t_r Rise time			30		ms
t_f Fall time		depending on I_o			

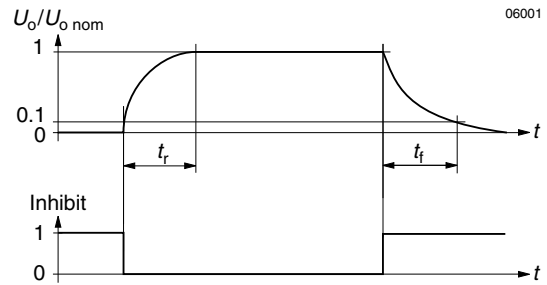

Fig. 16
Output response as a function of inhibit control

Battery Charging/Temperature Sensor

The LKP 5740-6R, LKP 5741-5R, LKP 5742-7R are intended for lead acid battery charger applications. For an optimum battery charging and life expectancy of the battery an external temperature sensor may be connected to the R-input. The sensor is mounted as close as possible to the battery pole and adjusts the output voltage of the LKP unit according to the temperature of the battery (which is related to the load of the battery and the ambient temperature).

Depending on the cell voltage and the temperature coefficient of the battery, different sensor types are available.

For more information please ask Power-One.

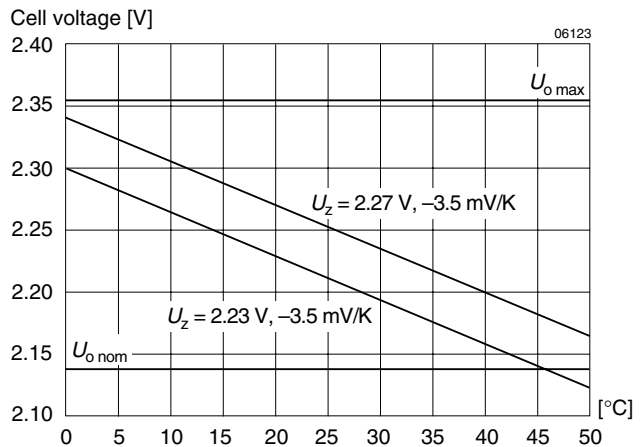

Fig. 17
Dependence of output voltage vs. temperature for defined temperature coefficient.

Programmable Output Voltage (R-Function)

As a standard feature, the modules offer an adjustable output voltage, identified by letter R in the type designation. The control input R (pin 16) accepts either a control voltage U_{ext} or a resistor R_{ext} to adjust the desired output voltage. When not connected, the control input automatically sets the output voltage to $U_{o nom}$.

a) Adjustment by means of an external control voltage U_{ext} between pin 16 (R) and pin 14:

The control voltage range is 0...2.75 V DC and allows an output voltage adjustment in the range of approximately 0...110% $U_{o nom}$.

$$U_{ext} = \frac{U_o}{U_{o nom}} \cdot 2.5 \text{ V (approximate formula)}$$

b) Adjustment by means of an external resistor:

Depending upon the value of the required output voltage the resistor shall be connected

either: Between pin 16 and pin 14 ($U_o < U_{o nom}$) to achieve an output voltage adjustment range of approximately 0...100% $U_{o nom}$

or: Between pin 16 and pin 12 ($U_o > U_{o nom}$) to achieve an output voltage adjustment range of approximately 100...110% $U_{o nom}$.

Remarks:

- The R-Function excludes option P (output voltage adjustment by potentiometer).
- If the output voltages are increased above $U_{o nom}$ via R-input control, option P setting, remote sensing or option T, the output current(s) should be reduced accordingly so that $P_{o nom}$ is not exceeded.
- The R-input (as well as option P) is related to the main output.
- With double output units the second output follows the value of the controlled main output. Resistor values as indicated for the single output units should be used.
- For correct output voltage adjustment of double output units the external wiring of the outputs should be according to: *R-function for different output configurations* depending upon the desired output configuration.
- In case of parallel connection the output voltages should be individually set within a tolerance of 1...2%.

Warning:

- U_{ext} shall never exceed 2.75 V DC.
- The value of R'_{ext} shall never be less than the lowest value as indicated in table R'_{ext} (for $U_o > U_{o nom}$) to avoid damage to the unit!

Table 6a: R_{ext} for $U_o < U_{o nom}$; approximate values ($U_{i nom}$, $I_{o nom}$, series E 96 resistors); $R'_{ext} = \infty$

$U_{o nom} = 24 \text{ V}$		
$U_o \text{ [V]}^1$		$R_{ext} \text{ [k}\Omega\text{]}$
4	8	0.806
6	12	1.33
8	16	2.00
10	20	2.87
12	24	4.02
14	28	5.62
16	32	8.06
18	36	12.1
20	40	20.0
22	44	44.2

¹ First column: single output units or double output units with separated outputs, second column: outputs in series connection

Table 6b: R'_{ext} for $U_o > U_{o nom}$; approximate values ($U_{i nom}$, $I_{o nom}$, series E 96 resistors); $R_{ext} = \infty$

$U_{o nom} = 24 \text{ V}$		
$U_o \text{ [V]}^1$		$R'_{ext} \text{ [k}\Omega\text{]}$
24.25	48.5	3320
24.5	49.0	1690
24.75	49.5	1130
25.0	50.0	845
25.25	50.5	698
25.5	51.0	590
25.75	51.5	511
26.0	52.0	442
26.25	52.5	402
26.4	52.8	383

Table 6c: R_{ext} for $U_o < U_{o nom}$; approximate values ($U_{i nom}$, $I_{o nom}$, series E 96 resistors); $R'_{ext} = \infty$

$U_{o nom} = 25.68 \text{ V}$		
$U_o \text{ [V]}^1$		$R_{ext} \text{ [k}\Omega\text{]}$
4	8	0.732
6	12	1.21
8	16	1.78
10	20	1.55
12	24	3.48
14	28	4.75
16	32	6.65
18	36	9.31
20	40	14.3
22	44	23.7
24	48	56.2

¹ First column: single output units or double output units with separated outputs, second column: outputs in series connection

Table 6d: R'_{ext} for $U_o > U_{o nom}$; approximate values ($U_{i nom}$, $I_{o nom}$, series E 96 resistors); $R_{ext} = \infty$

$U_{o nom} = 25.68 \text{ V}$		
$U_o \text{ [V]}^1$		$R'_{ext} \text{ [k}\Omega\text{]}$
26	52	3320
26.25	52.5	1780
26.5	53	1240
26.75	53.5	953
27	54	768
27.25	54.5	649
27.5	55	562
27.75	55.5	499
28	56	453
28.25	56.5	412

R-Function for different output configurations

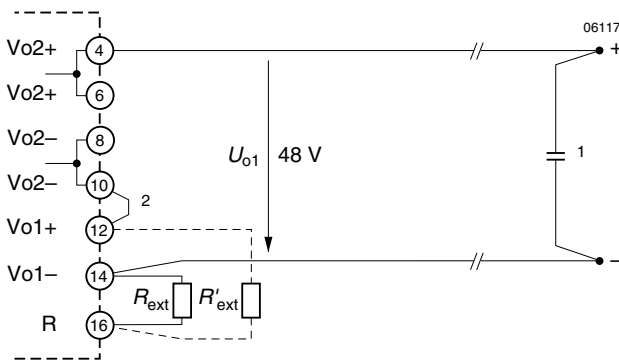

Fig. 18a
LKP 5000 with H15 connector. R-input for output voltage control. Wiring for output voltage 48 V with main and second output connected in series.

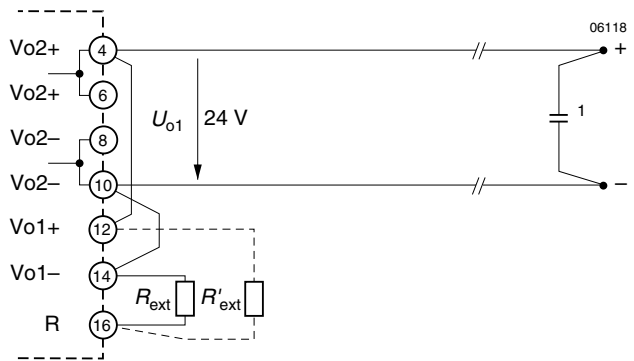

Fig. 18b
LKP 5000 with H15 connector. R-input for output voltage control. Wiring for output voltage 24 V with main and second output connected in parallel.

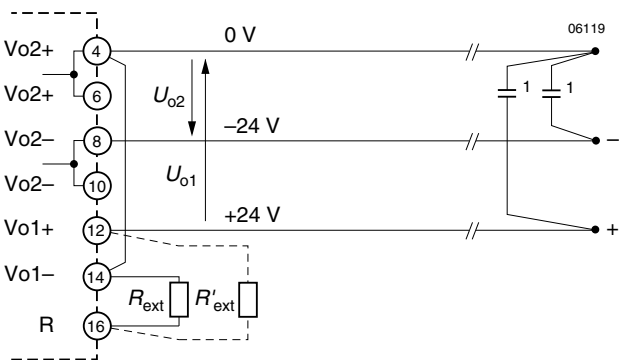

Fig. 18c
LKP 5000 with H15 connector. R-input for output voltage control. Wiring of main and second output for two symmetrical output voltages U_{o1} and U_{o2} : ± 24 V.

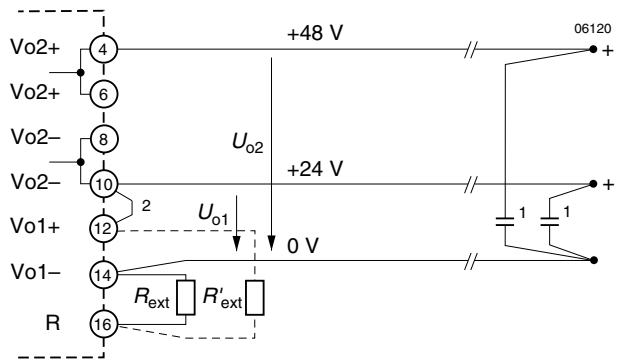

Fig. 18d
LKP 5000 with H15 connector. R-input for output voltage control. Wiring of main and second output for two output voltages U_{o1} and U_{o2} : +24 V and +48 V.

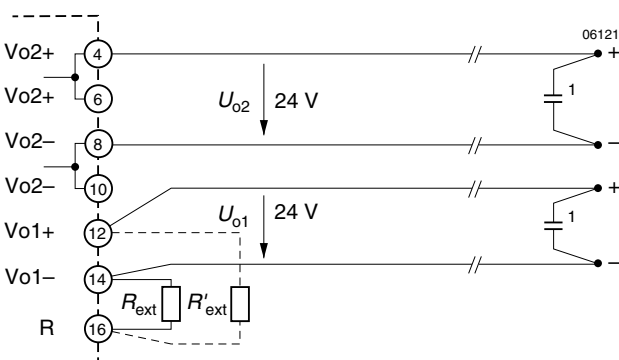

Fig. 18e
LKP 5000 with H15 connector. R-input for output voltage control. Wiring of main and second output for two output voltages U_{o1} and U_{o2} : 24 V/24 V, the outputs are galvanically isolated.

¹ A ceramic multilayer capacitor connected across the load reduces ripple and spikes.
² Shortest possible wiring for series connection at the female connector

Remarks:

Double output units fitted with H15 connectors have the output pins of the second output, pins 4/6 and 8/10, internally paralleled.

It is recommended that pins 4/6 and 8/10 be directly paralleled at the female connector as well to reduce the voltage drop across the connector.

Please note: U_{o2} varies depending upon its own load and the load on output 1.

Display Status of LEDs

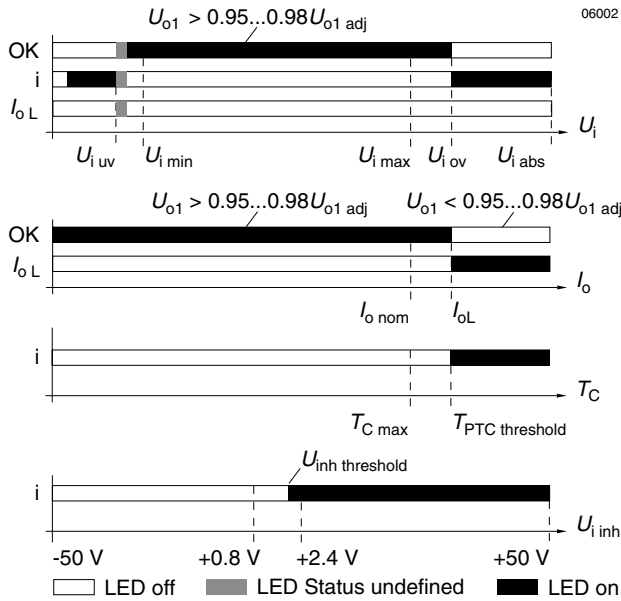

Fig. 19

LEDs "OK", "i" and " I_{oL} " status versus input voltage

Conditions: $I_o \leq I_{o \text{ nom}}$, $T_C \leq T_{C \text{ max}}$, $U_{i \text{ inh}} \leq 0.8 \text{ V}$

$U_{i \text{ uv}}$ = undervoltage lock-out, $U_{i \text{ ov}}$ = overvoltage lock-out

LEDs "OK" and " I_{oL} " status versus output current

Conditions: $U_i \text{ min} \dots U_i \text{ max}$, $T_C \leq T_{C \text{ max}}$, $U_{i \text{ inh}} \leq 0.8 \text{ V}$

LED "i" versus case temperature

Conditions: $U_i \text{ min} \dots U_i \text{ max}$, $I_o \leq I_{o \text{ nom}}$, $U_{i \text{ inh}} \leq 0.8 \text{ V}$

LED "i" versus $U_{i \text{ inh}}$

Conditions: $U_i \text{ min} \dots U_i \text{ max}$, $I_o \leq I_{o \text{ nom}}$, $T_C \leq T_{C \text{ max}}$

Test Sockets (Main output only)

Test sockets for measuring the output voltage U_{o1} are located at the front of the module. The positive test socket is protected by a series resistor (see: *Functional Description, block diagrams*). The voltage measured at the test sockets is approximately 30 mV lower than the value measured at the output terminals.

In case of double output units externally connected in series for $U_o = 51 \text{ V}$ or 48 V the monitored output voltage is 25,5 V or 24 V respectively.

Electromagnetic Compatibility (EMC)

A metal oxide VDR together with an input fuse and an input filter form an effective protection against high input transient voltages which typically occur in most installations.

The KP series has been successfully tested to the following specifications:

Electromagnetic Immunity

Table 7: Immunity type tests

Phenomenon	Standard ¹	Level	Coupling mode ²	Value applied	Waveform	Source imped.	Test procedure	In oper.	Per-form. ³	
Voltage surge	IEC 60571-1		i/c, +i/-i	800 V _p	100 μs	100 Ω	1 pos. and 1 neg. voltage surge per coupling mode	yes	⁴	
				1500 V _p	50 μs					
				3000 V _p	5 μs					
				4000 V _p	1 μs					
				7000 V _p	100 ns					
Supply related surge	RIA 12	B	+i/-i	1.5 • U _{batt}	0.1/1/0.1 s	0.2 Ω	1 positive surge	yes	⁴	
Direct transient		C	+i/c, -i/c	960 V _p	10/100 μs	5 Ω	5 pos. and 5 neg. impulses	yes	⁴	
		D		1800 V _p	5/50 μs					
		E		3600 V _p	0.5/5 μs					100 Ω
		F		4800 V _p	0.1/1 μs					
		G		8400 V _p	0.05/0.1 μs					
Indirect coupled transient		H	+o/c, -o/c	1800 V _p	5/50 μs	330 Ω	10 positive and 10 negative discharges	yes	A	
		J		3600 V _p	0.5/5 μs					
		K		4800 V _p	0.1/1 μs					
		L	8400 V _p	0.05/0.1 μs						
Electrostatic discharge (to case)	IEC/EN 61000-4-2	4	contact discharge	8000 V _p	1/50 ns	330 Ω	10 positive and 10 negative discharges	yes	A	
			air discharge	15000 V _p						
Electromagnetic field	IEC/EN 61000-4-3	3	antenna	10 V/m	AM 80% 1 kHz	n.a.	26...1000 MHz	yes	⁴	
Electromagnetic field, pulse modulated	ENV 50204				50% duty cycle, 200 Hz repetition frequency		900 ±5 MHz	yes	⁴	
Electrical fast transient/burst	IEC/EN 61000-4-4	4	capacitive, o/c	2000 V _p	bursts of 5/50 ns 2.5/5 kHz over 15 ms; burst period: 300 ms	50 Ω	1 min positive 1 min negative transients per coupling mode	yes	A	
			i/c, +i/-i direct	4000 V _p						
Surge	IEC/EN 61000-4-5	3	i/c	2000 V _p	1.2/50 μs	12 Ω	5 pos. and 5 neg. surges per	yes	B	
		4	+i/-i							2 Ω
Conducted disturbances	IEC/EN 61000-4-6	3	i, o, signal wires	10 V _{rms} (140 dBμV)	AM 80% 1 kHz	150 Ω	0.15...80 MHz	yes	⁴	
Voltage dips, short interruptions and voltage variations	IEC/EN 61000-4-11 (table of the standard)	40%	+i/-i	230 → 92 → 230 V	2/1/2 s	n.a.			B	
		0%		230 → 0 → 230 V					B	

¹ Related and previous standards are referenced in: *Technical Information: Standards.*

² i = input, o = output, c = case.

³ A = Normal operation, no deviation from specifications, B = Normal operation, temporary deviation from specs possible.

⁴ Test in progress, please consult factory.

Note: Previous standards are referenced in: *Technical Information: Standards.*

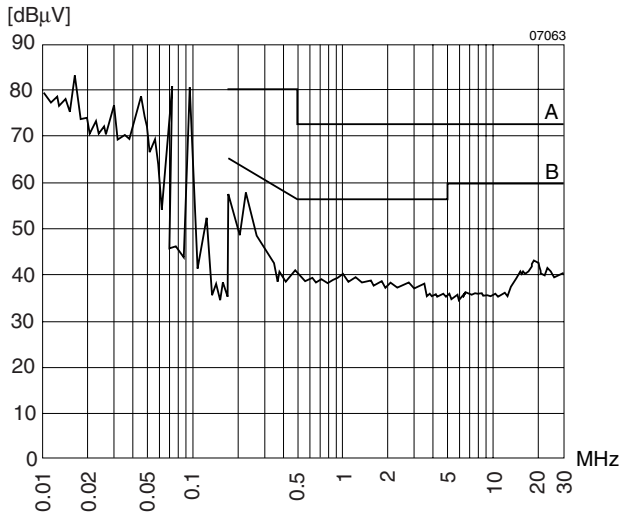

Fig. 20
Typical disturbance voltage (quasi-peak) at the input according to CISPR 11/22 and EN 55011/22, measured at $U_{i\text{ nom}}$ and $I_{o\text{ nom}}$.

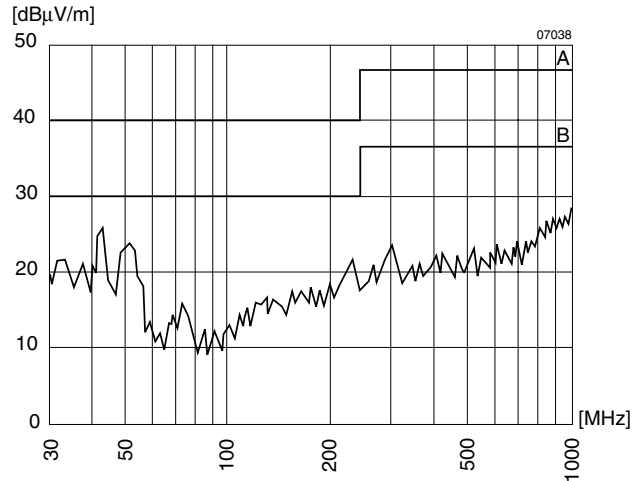

Fig. 21
Typical radiated electromagnetic field strength (quasi-peak) according to CISPR 11/22 and EN 55011/22, normalized to a distance of 10 m, measured at $U_{i\text{ nom}}$ and $I_{o\text{ nom}}$.

Immunity to Environmental Conditions

Table 8: Mechanical stress

Test method		Standard	Test conditions	Status
Ca	Damp heat steady state	IEC/DIN IEC 60068-2-3 MIL-STD-810D section 507.2	Temperature: $40 \pm 2 \text{ }^\circ\text{C}$ Relative humidity: $93^{+2/-3} \%$ Duration: 56 days	Unit not operating
Ea	Shock (half-sinusoidal)	IEC/EN/DIN EN 60068-2-27 MIL-STD-810D section 516.3	Acceleration amplitude: $100 g_n = 981 \text{ m/s}^2$ Bump duration: 6 ms Number of bumps: 18 (3 each direction)	Unit operating
Eb	Bump (half-sinusoidal)	IEC/EN/DIN EN 60068-2-29 MIL-STD-810D section 516.3	Acceleration amplitude: $40 g_n = 392 \text{ m/s}^2$ Bump duration: 6 ms Number of bumps: 6000 (1000 each direction)	Unit operating
Fc	Vibration (sinusoidal)	IEC/EN/DIN EN 60068-2-6 MIL-STD-810D section 514.3	Acceleration amplitude: 0.35 mm (10...60 Hz) $5 g_n = 49 \text{ m/s}^2$ (60...2000 Hz) Frequency (1 Oct/min): 10...2000 Hz Test duration: 7.5 h (2.5 h each axis)	Unit operating
Fda	Random vibration wide band Reproducibility high	IEC 60068-2-35 DIN 40046 part 23	Acceleration spectral density: $0.05 g_n^2/\text{Hz}$ Frequency band: 20...500 Hz Acceleration magnitude: $4.9 g_{n\text{ rms}}$ Test duration: 3 h (1 h each axis)	Unit operating
Kb	Salt mist, cyclic (sodium chloride NaCl solution)	IEC/EN/DIN IEC 60068-2-52	Concentration: 5% (30°C) Duration: 2 h per cycle Storage: 40°C , 93% rel. humidity Storage duration: 22 h per cycle Number of cycles: 3	Unit not operating

Table 9: Temperature specifications, values given are for an air pressure of 800...1200 hPa (800...1200 mbar)

Temperature			-5		-6		-7		Unit
Characteristics	Conditions		min	max	min	max	min	max	
T_A	Ambient temperature	$U_{i\text{ min}} \dots U_{i\text{ max}}$ $I_o = 0 \dots I_{o\text{ nom}}$	-25	50	-25	60	-25	71	°C
T_C	Case temperature		-25	85	-25	90	-25	95	
T_S	Storage temperature	Not operational	-40	100	-40	100	-40	100	

Mechanical Data

Dimensions in mm. Tolerances ± 0.3 mm unless otherwise indicated.

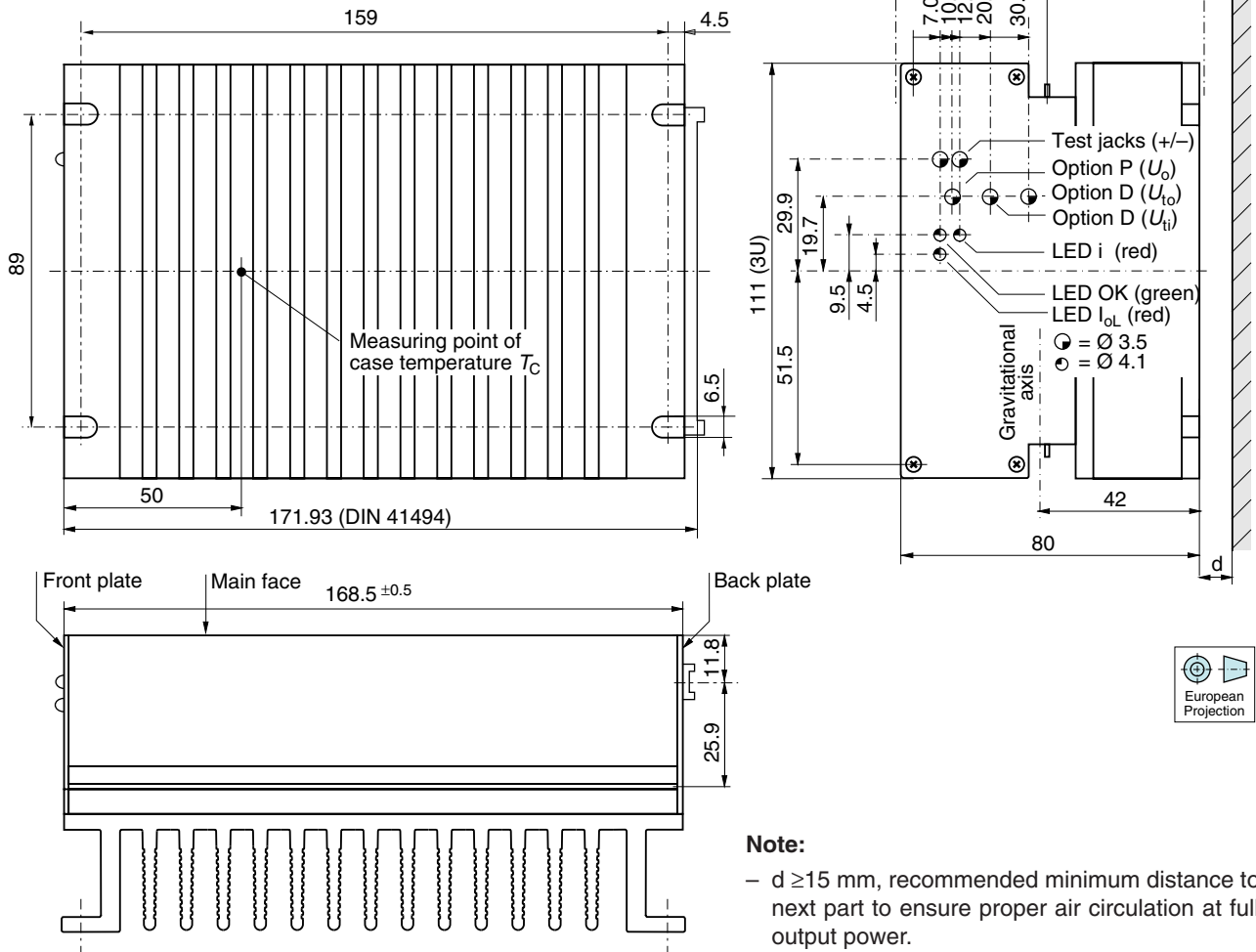

Fig. 22 Case K02 with heatsink, case aluminium, black finish and self cooling, weight: approx. 1.55 kg

- Note:**
- $d \geq 15$ mm, recommended minimum distance to next part to ensure proper air circulation at full output power.
 - free air locations: the module should be mounted with fins in vertical position to achieve a maximum air flow through the heat sink.

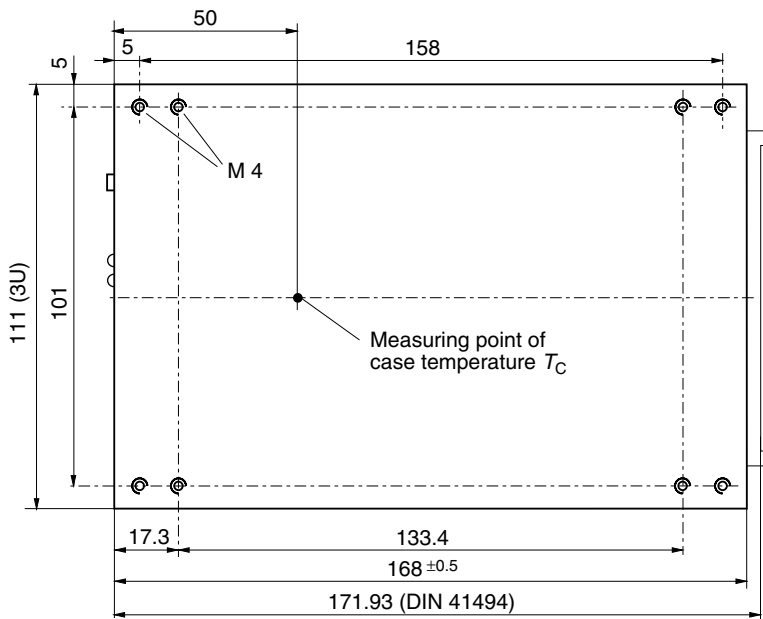

Fig. 23 Case K02 with option B1 (cooling plate), case aluminium, black finish and self cooling, weight: Approx. 1.15 kg

Safety and Installation Instructions

Connector Pin Allocation

The connector pin allocation table defines the electrical potentials and the physical pin positions on the H15 connector. Pin no. 24, the protective earth pin present on all LKP AC-DC converters is leading, ensuring that it makes contact with the female connector first.

Table 10: H15 connector pin allocation

Pin No.	Connector type H15	
	LKP 5000	
4	Vo2+	Output 2
6	Vo2+	Output 2
8	Vo2-	Output 2
10	Vo2-	Output 2
12	Vo1+	Output 1
14	Vo1-	Output 1
16	R ¹	Control of U_{o1}
18	i	Inhibit
20	D	Save data
22	T	Current sharing
24 ²	⊕	Protective earth
26	N ~	Neutral
28	N ~	Neutral
30	P ~	Phase
32	P ~	Phase

¹ Feature R excludes option P and vice versa

² Leading pin (pregrounding)

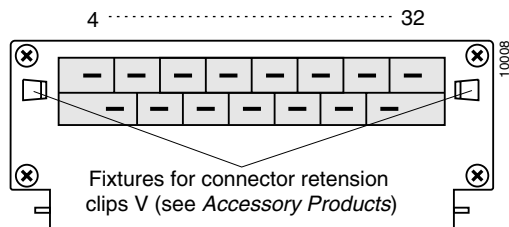

Fig. 24
View of module's male connectors

Protection Degree

Condition: Female connector fitted to the unit.

IP 30: All units except those with option P, and except those with option D with potentiometer.

IP 20: All units fitted with option P, or with option D with potentiometer.

Installation Instructions

The KP series AC-DC converters are components, intended exclusively for inclusion within other equipment by an industrial assembly operation or by professional installers. Installation must strictly follow the national safety regulations in compliance with the enclosure, mounting, creepage, clearance, casualty, markings and segregation requirements of the end-use application.

Connection to the system shall be made via the female connector H15 (see: *Accessories*). Other installation methods may not meet the safety requirements.

The AC-DC converters are provided with pin no. 24 (⊕), which is reliably connected with their case. For safety reasons it is essential to connect this pin with the protective earth of the supply system.

An input fuse is built-in in the connection from pins no. 30 and 32 (P~) of the unit. Since this fuse is designed to protect the unit in case of an overcurrent and does not necessarily cover all customer needs, an external fuse suitable for the application and in compliance with the local requirements might be necessary in the wiring to one or both input potentials, pins nos. 26 and 28 and/or nos. 30 and 32.

Important: Whenever the inhibit function is not in use, pin no. 18 (i) should be connected to pin no. 14 (Vo1-) to enable the output(s).

Do not open the modules, or guarantee will be invalidated.

Due to high current values, all LKP units provide two internally parallel connected contacts for certain paths (pins 4/6, 8/10, 26/28 and 30/32, respectively). It is recommended to connect load and supply to both female connector pins of each path in order to keep the voltage drop across the connector pins to an absolute minimum and to not overstress the connector contacts if currents are higher than approx. 8 A. The connector contacts are rated 8 A over the whole temperature range.

Make sure there is sufficient air flow available for convection cooling. This should be verified by measuring the case temperature when the unit is installed and operated in the end-use application. The maximum specified case temperature $T_{C \max}$ shall not be exceeded. See also: *Thermal Considerations*.

If the end-product is to be UL certified, the temperature of the main isolation transformer should be evaluated as part of the end-product investigation.

Check for hazardous voltages before altering any connections.

The output provides a hazardous energy level according to IEC/EN 60950.

Ensure that a unit failure (e.g. by an internal short-circuit) does not result in a hazardous condition. See also: *Safety of operator accessible output circuit*.

Cleaning Agents

In order to avoid possible damage, any penetration of cleaning fluids is to be prevented, since the power supplies are not hermetically sealed.

Standards and Approvals

All AC-DC converters correspond to class I equipment. They are UL recognized according to UL 1950, UL recognized for Canada to CAN/CSA C22.2 No. 950-95 and LGA approved to IEC/EN 60950 standards.

The units have been evaluated for:

- Building in
- Basic insulation between input and case, based on 250 V AC and 400 V DC
- Double or reinforced insulation between input and output, based on 250 V AC and 400 V DC
- Operational insulation between output and case.

- Operational insulation between output and output
- The use in a pollution degree 2 environment
- Connecting the input to a primary or secondary circuit which is subject to a maximum transient rating of 2500 V (overvoltage category III based on a 110 V primary circuit, overvoltage category II based on a 230 V primary circuit).

The AC-DC converters are subject to manufacturing surveillance in accordance with the above mentioned UL, CSA, EN and ISO 9001 standards.

Isolation

The electric strength test is performed as factory test in accordance with IEC/EN 60950 and UL 1950 and should not be repeated in the field. Power-One will not honour any guarantee claims resulting from electric strength field tests.

Important: Testing by applying AC voltages will result in high and dangerous leakage currents flowing through the Y-capacitors (see fig.: *Block diagram*).

Table 11: Isolation

Characteristic		Input to case	Input to output	Output to case	Output to output	Unit
Electric strength test voltage	Required according to IEC/EN 60950	1.5	3.0	–	–	kV _{rms}
		2.1	4.2	–	–	kV DC
	Actual factory test 1 s	2.8	5.6 ¹	1.4	0.14	
	AC test voltage equivalent to actual factory test	2.0	4.0 ¹	1.0	0.1	kV _{rms}
Insulation resistance at 500 V DC		>300	>300	>300	>100 ²	MΩ

¹ In accordance with IEC/EN 60950 only subassemblies are tested in factory with this voltage.
² Tested at 100 V DC.

For creepage distances and clearances refer to *Technical Information: Safety*.

Leakage Currents in AC-DC operation

Leakage currents flow due to internal leakage capacitance and RFI suppression Y-capacitors. The current values are proportional to the mains voltage and nearly proportional to the mains frequency and are specified at an input voltage of 254 V (50 Hz) where phase, neutral and protective earth are correctly connected as required for class I equipment.

Under test conditions the leakage current flows through a measuring instrument (MI) as described in fig.: *Measuring instrument for earth leakage current tests*, which takes into account impedance and sensitivity of a person touching unearthed accessible parts. The current value is calculated by dividing the measured voltage by 500 Ω. If inputs of K-units are connected in parallel, their individual leakage currents are added.

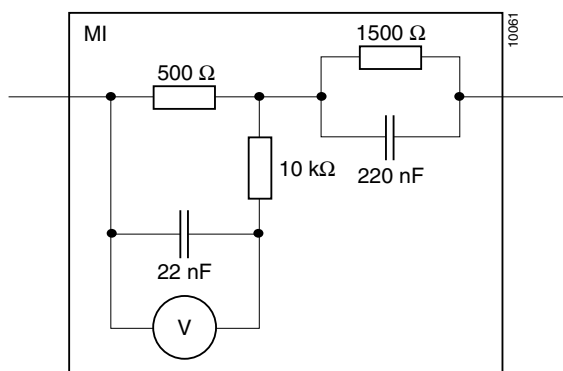

Fig. 25
Measuring instrument (MI) for earth leaking current tests according to IEC/EN 60950.

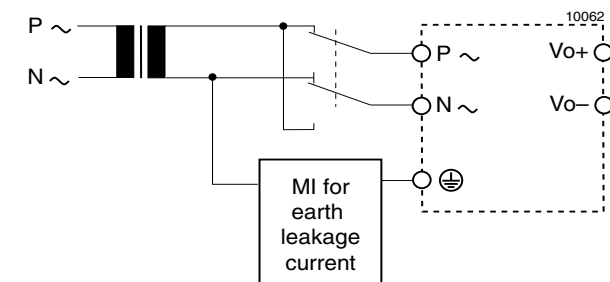

Fig. 26
Test set-up

Table 12: Leakage currents

Characteristic		Class I LKP 5000	Unit
Maximum earth leakage current	Permissible according to IEC/EN 60950	3.5	mA
	Specified value at 254 V, 50 Hz	0.82	

Safety of operator accessible output circuit

If the output circuit of an AC-DC converter is operator accessible, it shall be an SELV circuit according to the IEC/EN 60950 related safety standards.

The following table shows a possible installation configuration, compliance with which causes the output circuit of an KP series AC-DC converter to be an SELV circuit according

to IEC/EN 60950 up to a configured output voltage (sum of nominal voltages if in series or +/- configuration) of 36 V.

However, it is the sole responsibility of the installer to assure the compliance with the relevant and applicable safety regulations. More information is given in: *Technical Information: Safety*.

Table 13: Safety concept leading to an SELV output circuit

Conditions	AC-DC converter	Installation	Result
Nominal voltage	Grade of insulation between input and output provided by the AC-DC converter	Measures to achieve the resulting safety status of the output circuit	Safety status of the AC-DC converter output circuit
Mains ≤250 V AC	Double or reinforced	Earthed case ¹ and installation according to the applicable standards	SELV circuit

¹ The earth connection has to be provided by the installer according to the relevant safety standards, e.g. IEC/EN 60950.

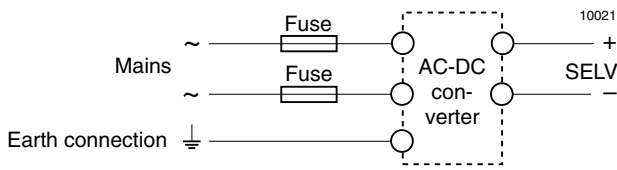

Fig. 27 Schematic safety concept. Use fuses and earth connection as per :Installation Instructions and table: Safety concept leading to an SELV output circuit.

Description of Options

Table 14: Survey of options

Option	Function of Option	Characteristics
E	Electronic inrush current limitation circuitry	Active inrush current limitation
P ^{1,2}	Potentiometer for fine adjustment of output voltage	Adjustment range +10/-60% of $U_{o\ nom}$ excludes R input
D	Input and/or output undervoltage monitoring circuitry	Safe data signal output (Versions D0...DD)
T	Current sharing	Interconnect T-pins if paralleling outputs (3 units max.)
B1	Cooling plate	Replaces standard heat sink, allowing direct chassis-mounting

¹ Option R excludes option P and vice versa.
² Option P not available for LKP 5740-6R

Option T Current Sharing

This option ensures that the output currents are approximately shared between all paralleled modules and increases system reliability. To use this facility, simply interconnect the T pins of all modules. The load leads should have equal length and cross section to ensure equal voltage drops. Not more than 3 units should be connected in parallel. If output voltage adjustment is requested we strongly recommend to use the R-input instead of option P, as with option P the required setting accuracy is difficult to achieve. The output voltages must be individually set prior to paralleling to within a tolerance of 1...2% or the R pins should be connected together.

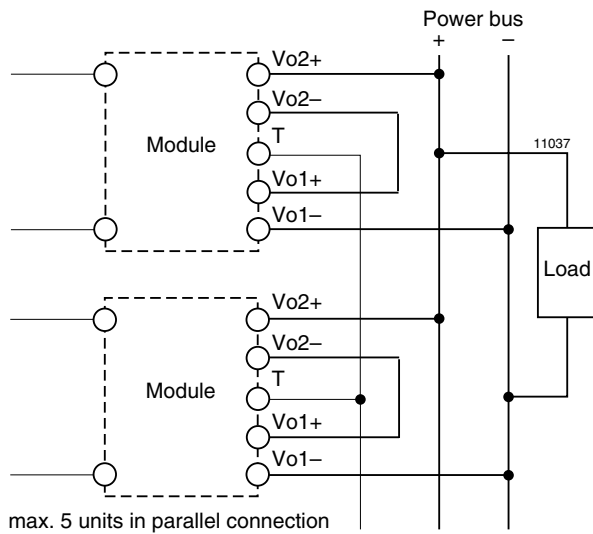

Fig. 28
Paralleling of double output units using option T with Power Bus

Option P Potentiometer

The potentiometer provides an output voltage adjustment range of +10/-60% of $U_{o\ nom}$ and is accessible through a hole in the front cover. This feature enables compensation for voltage drops across the connector and wiring. Option P is not recommended if units are connected in parallel.

Option P excludes the R-function. With double output units both outputs are affected by the potentiometer setting (doubling the voltage setting if the outputs are in series).

If the output voltages are increased above $U_{o\ nom}$ via R-input control, option P setting, remote sensing or option T, the output current(s) should be reduced accordingly so that $P_{o\ nom}$ is not exceeded.

E Inrush Current Limitation

The converters may be supplemented by an electronic circuit (option E, replacing the standard built-in NTC) to achieve an enhanced inrush current limiting function.

Table 15: Inrush current characteristics with option E

Characteristics		LKP		Unit
$U_i = 230\ V\ AC$		typ	max	
$I_{inr\ p}$	Peak inrush current	-	21.7	A
t_{inr}	Inrush current duration	35	50	ms

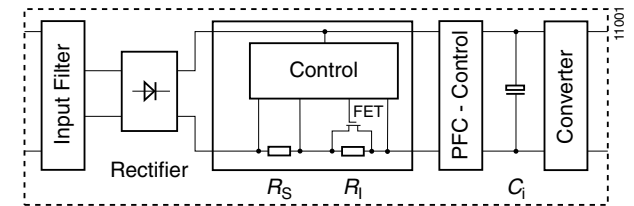

Fig. 29
Option E block diagram

Precaution:
 Subsequent switch-on cycles at start-up are limited to max. 10 cycles during the first 20 seconds (cold unit) and at continuing on/off ($T_C = 95^\circ C$) max. 1 cycle every 8 sec.

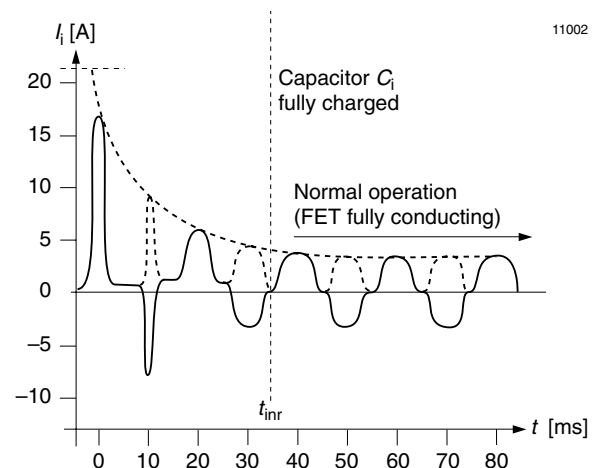

Fig. 30
Inrush current with option E, $U_i = 230\ V\ AC$, $P_o = P_{o\ nom}$

Option D Undervoltage Monitor

The input and/or output undervoltage monitoring circuit operates independently of the built-in input undervoltage lock-out circuit. A logic "low" (JFET output) or "high" signal (NPN output) is generated at pin 20 as soon as one of the monitored voltages drops below the preselected threshold level U_t . The return for this signal is Vo1-. The D output recovers when the monitored voltage(s) exceed(s) $U_t + U_h$. The

threshold level U_{ti} is adjusted in the factory. The threshold level U_{to} is either adjusted by a potentiometer, accessible through a hole in the front cover, or factory adjusted to a fixed value specified by the customer.

Option D exists in various versions D0...DD as shown in the following table.

Table 16: Undervoltage monitoring functions

Output type		Monitoring		Minimum adjustment range of threshold level U_t		Typical hysteresis U_{ho} [% of U_t] for $U_{t\ min} \dots U_{t\ max}$
JFET	NPN	U_i	U_{o1}	U_{ti}	U_{to}	
D1	D5	no	yes	-	3.5...40 V ¹	2.5...0.6
D2	D6	yes	no	355 V DC ⁴	-	-
D3	D7	yes	yes	355 V DC ⁴	$(0.95 \dots 0.985 U_{o1})^2$	"0"
D4	D8	no	yes	-	$(0.95 \dots 0.985 U_{o1})^2$	"0"
D0	D9	no	yes	-	3.5...40 V ³	2.5...0.6
		yes	yes	355 V DC ⁴	3.5...40 V ³	2.5...0.6
	DD	yes	yes	355 V DC ⁴	3.5...40 V ¹	2.5...0.6

¹ Threshold level adjustable by potentiometer

² Fixed value. Tracking if U_{o1} adjusted via R-input, option P or sense lines.

³ The threshold level permanently adjusted according to customer specification $\pm 2\%$ at 25°C. Any value within the specified range is basically possible but causes a special type designation in addition to the standard option designations (D0/D9)!

⁴ Option D monitors the boost regulator output voltage. The trigger level is adjusted in the factory to 355 V DC.

JFET output (D0...D4):

Connector pin D is internally connected via the drain-source path of a JFET (self-conducting type) to the negative potential of output 1. $U_D \leq 0.4$ V (logic low) corresponds to a monitored voltage level (U_i and/or U_{o1}) $< U_t$. The current I_D through the JFET should not exceed 2.5 mA. The JFET is protected by a 0.5 W Zener diode of 8.2 V against external overvoltages.

U_i, U_{o1} status	D output, U_D
U_i or $U_{o1} < U_t$	low, L, $U_D \leq 0.4$ V at $I_D = 2.5$ mA
U_i and $U_{o1} > U_t + U_h$	high, H, $I_D \leq 25$ μ A at $U_D = 5.25$ V

NPN output (D5...DD):

Connector pin D is internally connected via the collector-emitter path of a NPN transistor to the negative potential of output 1. $U_D < 0.4$ V (logic low) corresponds to a monitored voltage level (U_i and/or U_{o1}) $> U_t + U_h$. The current I_D through the open collector should not exceed 20 mA. The NPN output is not protected against external overvoltages. U_D should not exceed 40 V.

U_i, U_{o1} status	D output, U_D
U_i or $U_{o1} < U_t$	high, H, $I_D \leq 25$ μ A at $U_D = 40$ V
U_i and $U_{o1} > U_t + U_h$	low, L, $U_D \leq 0.4$ V at $I_D = 20$ mA

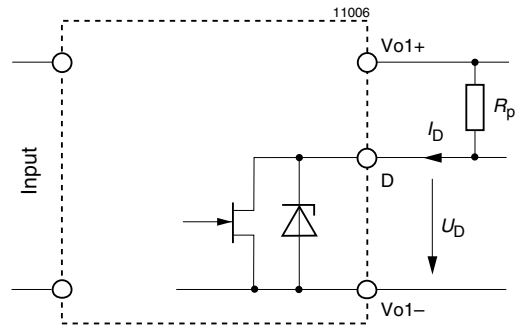

Fig. 31 Option D0...D4: JFET output, $I_D \leq 2.5$ mA

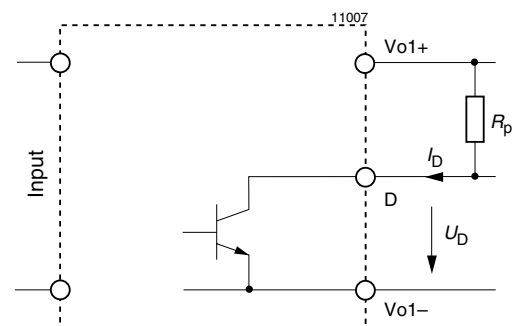

Fig. 32 Option D5...DD: NPN output, $U_{o1} \leq 40$ V, $I_D \leq 20$ mA

Table 17: D-output logic signals

Version of D	$U_i < U_t$ resp. $U_o < U_t$	$U_i > U_t + U_h$ resp. $U_o > U_t$	Configuration
D1, D2, D3, D4, D0	low	high	JFET
D5, D6, D7, D8, D9, DD	high	low	NPN

D-signal with respect to input and output voltage versus time:

Input voltage monitoring

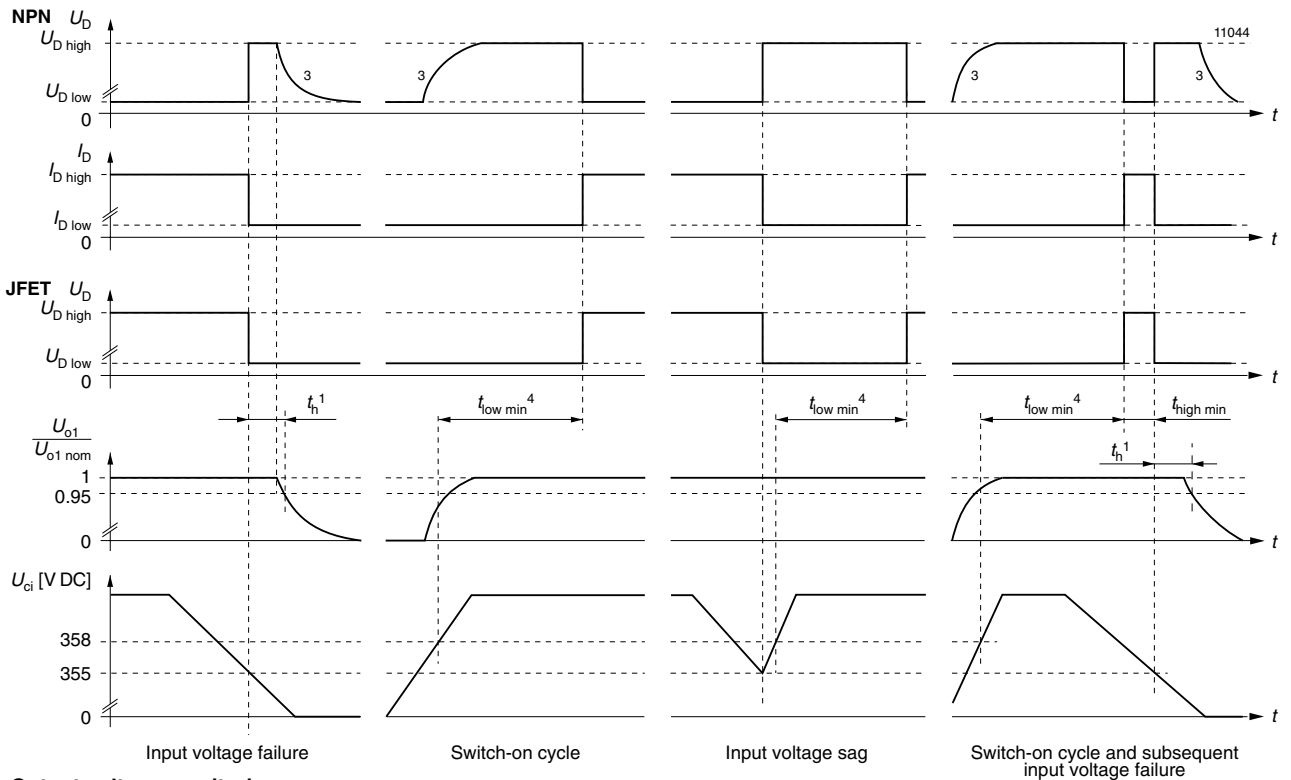

Output voltage monitoring

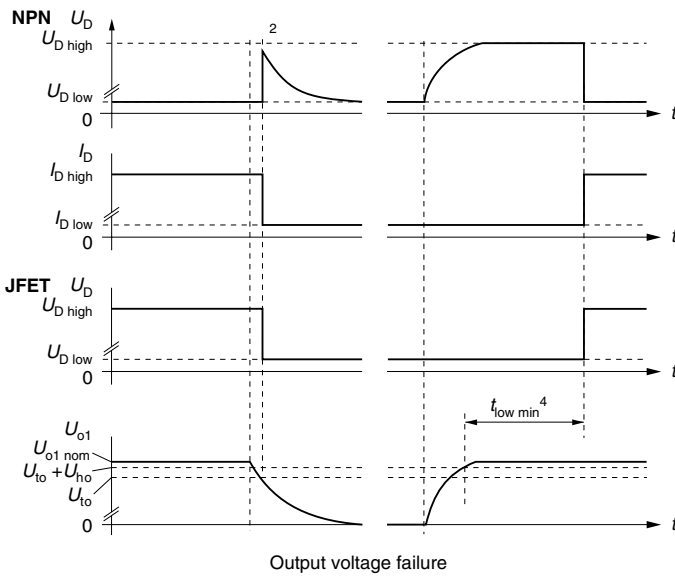

¹ Hold-up time see section: *Electrical Input Data*.
² With output voltage monitoring, hold-up time $t_h = 0$.
³ The signal will remain high if the D output is connected to an external source.
⁴ $t_{low\ min} = 100...170$ ms, typically 130 ms.

Fig. 33
 Relationship between U_{ci} , U_{o1} , U_D , $U_{o1}/U_{o\ nom}$ versus time

B1 Cooling Plate (see: *Mechanical Data*)

Where a cooling surface is available, we recommend the use of a cooling plate (option B1) instead of the standard heatsink. The mounting system should ensure sufficient cooling capacity to guarantee that the maximum case temperature T_{Cmax} is not exceeded. The cooling capacity is calculated by:

$$P_{Loss} = \frac{(100\% - \eta)}{\eta} (U_o \cdot I_o)$$

Efficiency η see: *Type survey*.

Accessories

A variety of electrical and mechanical accessories are available including:

- Front panels for 19" rack mounting, Schroff and Intermas systems.
- Mating H15 connectors with screw, solder, fast-on or press-fit terminals.
- Connector retention facilities.
- Code key system for connector coding.
- Chassis mounting plates for mounting the 19" cassette to a chassis/wall where only frontal access is given.
- Universal mounting bracket for DIN-rail or chassis mounting.

For more detailed information please refer to: *Accessory Products*.



Front panels

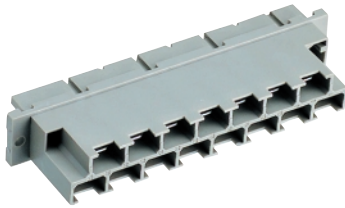

*H15 female connector,
Code key system*



*Mounting plate,
Connector retention clips*

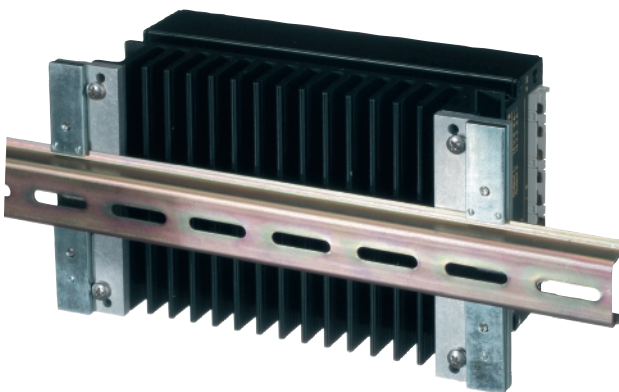

Universal mounting bracket for DIN-rail mounting.