



# TP8452

## *PS/2 2D 3Key Mouse Controller*

# *DataSheet*

*Version: 1.0*

*Apr/2002*

<http://www.topro.com.tw>

5 F, No.10, Prosperity Road 1, Science-Based Industrial Park, Hsinchu 300, Taiwan, R.O.C  
300 新竹科學工業園區展業一路 10 號 5 樓

**TPE:**

5 F, No.27, Min Chuan W. Rd. Taipei 104, Taiwan, R.O.C  
104 台北市民權西路 27 號 5 樓

**SHENZHEN:**

Room 802, Tower A, World Trade Plaza, Fahong Rd., Fatian, Shenzhen, China  
深圳市福田區福虹路 9 號世貿廣場 A 座 802 室(郵編: 518033)

*H.Q.: Tel:886-3-5632515 Fax:886-3-5641728*

*TPE.: Tel:886-2-25856858 Fax:886-2-25941104*

*SHENZHEN:TEL:755-3679985 Fax:755-3679518*



# TP8452

## *PS/2 2D 3Key Mouse Controller*

---

### General Specification

#### General Description

The TP8452 Mouse Controller is specially designed to control PS/2 mouse device. This single chip can interface three key-switches and four photo-couples direct to 8042. TP8452 can receive command and echo status or data format which are compatible with IBM PS/2 mode mouse.

Key debouncing circuit is provided to prevent false entry and improve TP8452 accuracy.

In the conventional mouse, a great number of noises are generated when the grid is partially closed or opened. These noises are usually mistaken for movement signals by conventional mouse controller and the cursor of the display screen is thus moved frequently up and down or back and forth. This will consumes a great amount of energy. The TP8452 PS/2 mouse controller provides noise immunity circuits to eliminate these noises in order to reduce energy consumption.

Using the auto-speed adjusting circuits, TP8452 promotes the power of the mouse in movement. when TP8452 moves at low speed, it will be very smooth. While at high speed, TP8452 can change the scanning ability of the motion and detects more dots than that of at low speed. According to different speed, the horizontal and vertical counters acquire different dots in the same distance.

#### Features

- \* Being compatible with PS/2 mouse mode.
- \* Including buyer testing mode.
- \* Auto speed with dynamic resolutions.
- \* Built-in noise immunity circuit.
- \* Low power dissipation.
- \* Both RC oscillating and crystal oscillating circuits provided.
- \* Three key-switches and four photo-couples inputs.
- \* Both key-press and key-release debounce interval 11 ms.
- \* Through three key-switch inputs, TP8452 can exert seven different output.
- \* PIN to PIN compatible with HM8450.
- \* Improved ESD protection.



# TP8452

## *PS/2 2D 3Key Mouse Controller*

---

### **Applications**

- \* Optical mouse or pen-mouse.
- \* Mechanical mouse or pen-mouse.
- \* Optomechanical mouse or pen-mouse.
- \* Mechanical track ball.
- \* Optomechanical track ball.



# TP8452

## *PS/2 2D 3Key Mouse Controller*

---

### Contents :

<b>1. General Specification</b>	<i>P. 2</i>	<i>--- P. 3</i>
<b>2. Pin Configurations and Package Type</b>	<i>P. 5</i>	<i>--- P. 5</i>
<b>3. Pin Descriptions</b>	<i>P. 6</i>	<i>--- P. 6</i>
<b>4. Functional Block Diagram</b>	<i>P. 7</i>	<i>--- P. 7</i>
<b>5. Function Descriptions</b>	<i>P. 8</i>	<i>--- P. 16</i>
<b>6. Absolute Maximum Ratings</b>	<i>P. 17</i>	<i>--- P. 17</i>
<b>7. DC Electrical Characteristic</b>	<i>P. 17</i>	<i>--- P. 18</i>
<b>8. AC Electrical Characteristic</b>	<i>P. 18</i>	<i>--- P. 19</i>
<b>9. Application Diagrams</b>	<i>P. 20</i>	<i>--- P. 20</i>

TOPRO

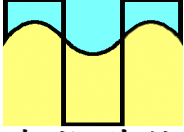

凌越科技  
Topro Technology Inc.

# TP8452

## *PS/2 2D 3Key Mouse Controller*

### Pin Configurations and Package Type

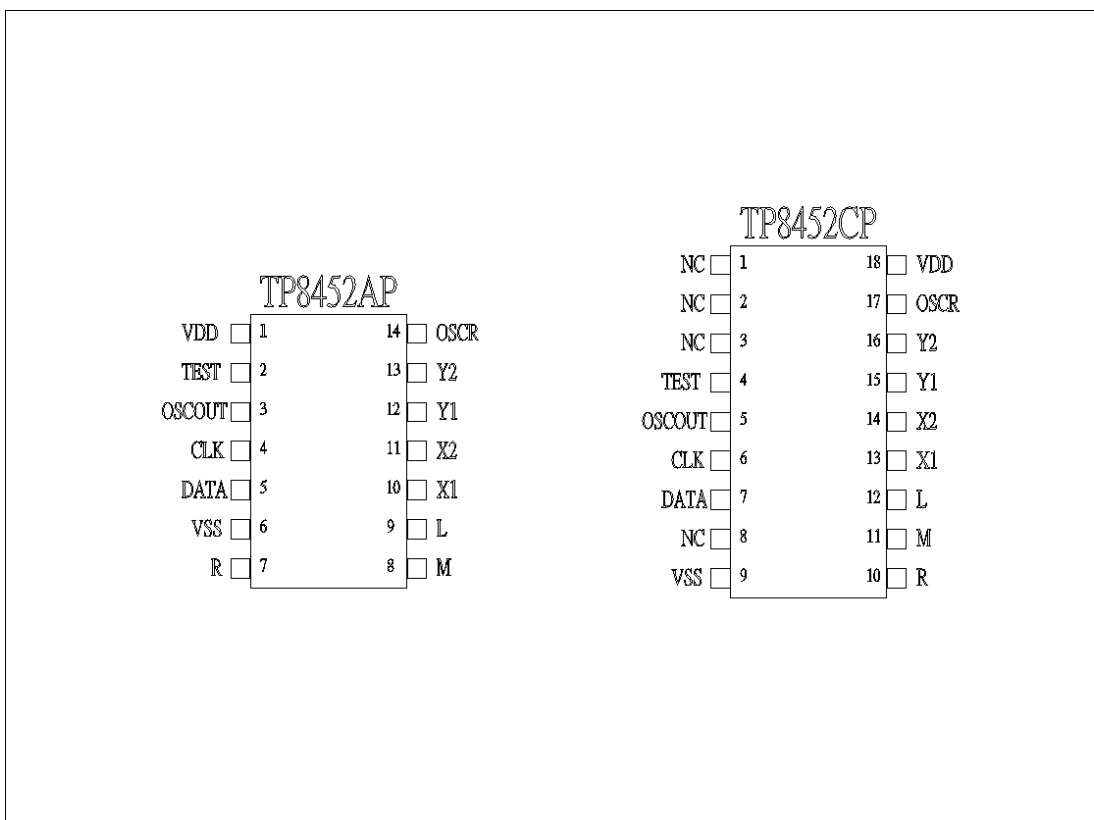

### Pin Descriptions

Pin	Name	I/O	Function
1	18	VDD	I Power.
2	4	Test	If it is connected to VDD or floated, TP8452 will work on normal operation. While it is connect to GND, TP8452 will enter testing mode, you can use OSCR to select two types of testing mode.
3	5	OSC.OUT	O Clock output
4	6	CLK	I/O 8042 auxiliary port CLK line
5	7	DATA	I/O 8042 auxiliary port DATA line
6	9	VSS	Ground.
7	10	R	I Three key-switches exert seven different combinations totally.
8	11	M	I/O Both key-pressed and key-released signals accompanied with
9	12	L	I/O horizontal and vertical state will be sent to the host. The status of the key-switches will be preserved when RXD is transmitting. The debounce interval for both key-press and key-release is 12 ms.  In testing mode, L and M are the outputs of motion detector. Use R key can select the two outputs from X1, X2 or Y1, Y2. This feature can help manufacture to adjust the phase of four photo-couples for improving the yield.
10	13	X1	I Four photo-couple signals denote UP, DOWN, LEFT, and RIGHT
11	14	X2	state During the scanning period, as long as the photo-couples
12	15	Y1	change their states, the value of vertical or horizontal counter
13	16	Y2	will accordingly increase or decrease.
14	17	OSCR	I If it is connected a 30kohm resistor to ground, TP8452 will employ a built in RC ckt to generate clock. While it is connected to VDD, and Test connect to GND, it will enter testing mode, you can observe X/Y input on L/M pin.

### Functional Block Diagram

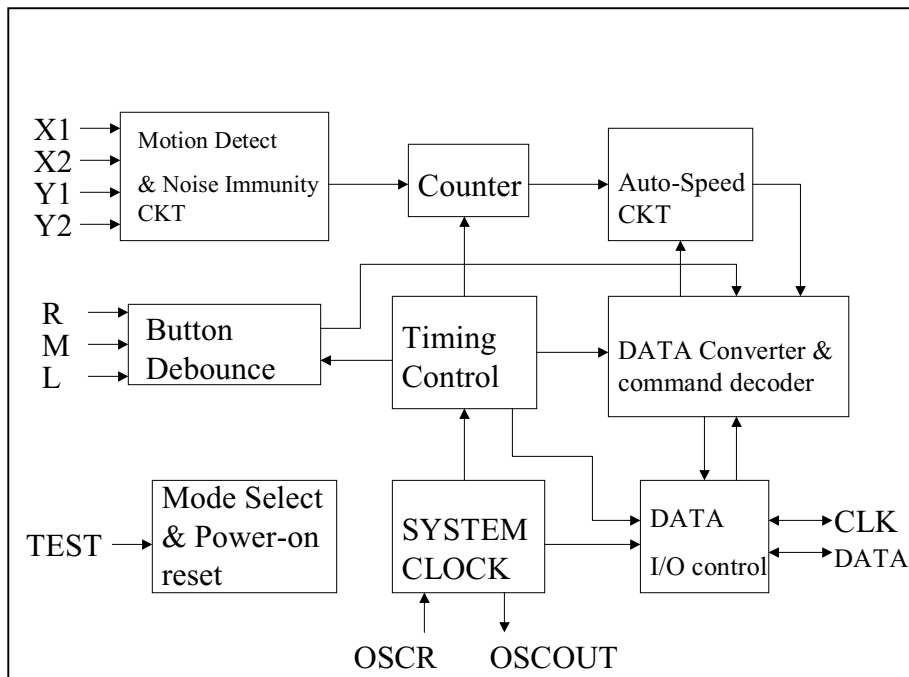



# TP8452

## *PS/2 2D 3Key Mouse Controller*

---

### Function Descriptions

#### (1) PS/2 Mouse Mode

##### (A) Operating mode

There are four operating modes in PS/2 mouse :

##### a. Reset Mode :

In this mode a self-test is initiated during power-on or by a Reset command. After reset signal, PS/2 mouse will send:

(a) Completion code AA & ID code 00.

(b) Set default:

sampling rate: 100 reports/s

non-autospeed

stream mode

4 counts/mm

disable

##### b. Stream Mode:

The maximum rate of transfer is the programmed sampling rate.

Data report is transmitted if

(a) switch is pressed

(b) movement has been detected

##### c. Remote Mode:

Data is transmitted only in response to a Read Data command.

##### d. Wrap Mode:

Any byte of data sent by the system, except hex EC ( Reset wrap mode ) or hex FF ( Reset ), is returned by TP8452.





# TP8452

## *PS/2 2D 3Key Mouse Controller*

(B) PS/2 Mouse Data Report:

- a. In stream mode: A data report is sent at the end of a sample interval.
- b. In remote mode: A data report is sent in response to Read Data command.
- c. Data report format:

Byte	Bit	Description
1	0	Left button status; 1 = pressed
	1	Right button status; 1 = pressed
	2	Middle button status; 1 = pressed
	3	Reserved
	4	X data sign; 1 = negative
	5	Y data sign; 1 = negative
	6	X data overflow; 1 = overflow
	7	Y data overflow; 1 = overflow
2	0-7	X data ( D0 - D7 )
3	0-7	Y data ( D0 - D7 )

(C) PS/2 mouse Data Transmission:

- a. TP8452 generates the clocking signal when sending data to and receiving data from the system.
- b. The system requests TP8452 to receive system data output by forcing the DATA line to an inactive level then allowing CLK line to go to an active level.
- c. Data transmission frame:

Bit	Function
1	Start bit ( always 0 )
2-9	Data bits ( D0 - D7 )
10	Parity bit ( odd parity )
11	Stop bit ( always 1 )

d. Data Output ( data from TP8452 to system ):

If CLK keep low (inhibit status), data will not transmit.

If CLK raised to high and DATA is low(request-to-send),data is updated.

After receiving data from system, TP8452 will not start transmitting until CLK and DATA are both high.

If CLK and DATA are both high, the transmission is ready.

DATA is valid prior to the falling edge of CLK and beyond the rising edge of CLK. During transmission, TP8452 check for line contention by checking for an inactive level on CLK lasting for no more than 100m sec.

Contention occurs when the system lowers CLK to inhibit TP8452 output after TP8452 has started a transmission. If this occurs before the rising edge of the tenth clock, TP8452 internal store its data in its buffer and returns DATA and CLK to an active level. If the contention does not occur by the tenth clock, the transmission is completed.

Following a transmission, the system inhibits TP8452 by holding CLK low until it can service the input or until the system receives a request to send a response from TP8452.

e. Data Input ( from system to TP8452):

System first check if TP8452 is transmitting data. If TP8452 is transmitting, the system can override the output by forcing CLK to an inactive level prior to the tenth clock. If the transmission of TP8452 beyond the tenth clock ,the system must receive the data.

If TP8452 is not transmitting or if the system choose to override the output, the system force CLK to an inactive level for a period of not less than 100u sec while preparing for output. When the system is ready to output start bit (0), it allows CLK to go to active level.

If request-to-send is detected, TP8452 clocks in 11 bits. Following the tenth clock,TP8452 checks for an active level on the DATA line, and if found, force DATA low , and clock once more.

If framing error occurs, TP8452 continue to clock until DATA is high, then clocks the line control bit and request a Resend.

When the system sends out a command or a data that requires a response, the system must wait for TP8452 to response before sending its next output.

(D) PS/2 Mouse Error Handling:



# TP8452

## PS/2 2D 3Key Mouse Controller

- a. A Resend command ( FE ) following receipt of an invalid input or any input with incorrect polarity.
- b. If two invalid input are received in succession, an error code of hex FC will be sent to the system.
- c. The counter accumulators are cleared after receiving any command except “Resend”.
- d. As TP8452 receives a Resend command ( FE ), it transmits its last packet of data.
- e. In the stream mode “Resend” is received by TP8452 following a 3-byte data packet transmission to the system. TP8452 resend the 3-byte data packet prior to clearing the counter.
- f. A response is sent within 25 ms if
  - (a) The system requires a response
  - (b) An error is detected during transmission
- g. When a command requiring a response is issued by the system ,another command should not be issued until either the response is received or 25ms has passed.

(E) PS/2 Mouse Commands Description:

There are 16 valid commands that transmits between the system and TP8452. The “EA” code is always the first response to any valid input received from the system other than a Set Wrap Mode or Resend command.

The following table list the commands:

Hex Code	Command	TP8452 echo code
FF	Reset	FA,AA,00
FE	Resend	XX,(XX,XX)
F6 Set	Default	FA
F5	Disable	FA
F4	Enable	FA
F3,XX	Set Sampling	Rate FA,FA
F2	Read Device Type	FA,00
F0	Set Remote Mode	FA



# TP8452

## *PS/2 2D 3Key Mouse Controller*

EE	Set Wrap Mode	FA
EC	Reset Wrap Mode	FA
EB	Read Data	FA,XX,XX,XX
EA	Set Stream Mode	FA
E9	Status Request	FA,XX,XX,XX
E8,XX	Set Resolution	FA,FA
E7	Set Autospeed	FA
E6	Reset Autospeed	FA

The following describes valid commands:

a. Reset ( FF )

TP8452 operation:

- (a) Complete the reset.
- (b) Transmit FA,AA,00 to the system.
- (c) Set default:
  - sampling rate: 100 reports/s
  - non-autospeed
  - stream mode
  - 4 counts/mm
  - disable

b. Resend ( FE )

- (a) Any time TP8452 receives an invalid command, it returns a Resend command to the system.
- (b) When TP8452 receives a Resend command, it retransmits its last output. If the last packet was a Resend command, it transmits the packet just prior to the Resend command.



# TP8452

## *PS/2 2D 3Key Mouse Controller*

(c) In stream mode, if a Resend command is received by TP8452 immediately following a 3-byte data packet transmission to the system, TP8452 will resend the 3-byte data packet prior to cleaning the count accumulators.

c. Set Default ( F6 )

The command reinitializes all conditions to the power-on defaults.

d. Disable ( F5 )

This command is used in the stream mode to disable transmissions from TP8452.

e. Enable ( F4 )

Enable transmissions, if in stream mode.

f. Set Sampling Rate ( F3,XX )

In the stream mode, this command sets the sampling rate to the value indicated by byte hex XX, shown as follows:

Second byte XX	Sample Rate
0A	10/sec
14	20/sec
28	40/sec
3C	60/sec
50	80/sec
64	100/sec
C8	200/sec

g. Read Device Type ( F2 )

TP8452 always echoes “ FA,00 “ following this command.

h. Set Remote Mode ( F0 )

Data value are reported only in response to a Read Data command.



# TP8452

## *PS/2 2D 3Key Mouse Controller*

i. Set Wrap Mode ( EE )

Wrap mode remains until Reset ( FF ) or Reset Wrap Mode( EC ) is received.

j. Reset Wrap Mode ( EC )

TP8452 returns to the previous mode of operation after receiving this command.

k. Read Data ( EB )

This command is executed in either remote or stream mode. The data is transmitted even if there has been no movement or the button status is unchanged since the last report.

Following a Read Data command, the registers are cleared after a data transmission.

l. Set Stream Mode ( EA )

This command sets TP8452 in stream mode.

m. Status Request ( E9 )

When this command is issued by the system, TP8452 responds with a 3-byte status report as follows:

Byte	Bit	Description
1	0	1 = Right button pressed
	1	1 = Middle button pressed
	2	1 = Left button pressed
	3	Reserved
	4	0 = Normal speed, 1 = Autospeed
	5	0 = Disabled, 1 = Enabled
	6	0 = Stream mode, 1 = Remote mode
2	7	Reserved
	0-7	Current resolution setting ( D0 - D7 )
3	0-7	Current sampling rate ( D0 - D7 )



# TP8452

## *PS/2 2D 3Key Mouse Controller*

n. Set Resolution ( E8,XX )

TP8452 provides four resolutions selected by the second byte of this command as follows:

Second Byte XX	Resolution
00	1 counts/mm
01	2 counts/mm
02	4 counts/mm
03	8 counts/mm

o. Set Autospeed ( E7 )

At the end of a sample interval in the stream mode, the current X and Y data values are converted new values. The sign bits are not involved in this conversion. The conversion is only in stream mode. The relationship between the input and output count is as follows:

Input	Output
0	0
1	1
2	1
3	3
4	6
5	9
N( >=6 )	2.0*N

p. Reset Autospeed ( E6 )

This command restore normal speed.



# TP8452

## *PS/2 2D 3Key Mouse Controller*

---

### (2) Testing Mode

Whenever "Test" pin is connected to GND, the chip will enter buyer's testing mode.

If OSCR (connect to VDD) = "1" : The X direction output signals of comparators will present to "L" and "M" pin. Pressing "R" key can toggle the output from X direction to Y direction.

If OSCR (connect to GND) = "0" : The TP8452'S Internal RC won't generate clock. you can input clock on OSC.OUT pin to let TP8452 work on normal operation.



### Absolute Maximum Ratings

Parameter	Min.	Ratings	Max.	Unit
Supply voltage	-0.3		7.5	V
Temperature under bias	0		70	°C
Storage temperature range	-65		150	°C
Power dissipation	-		500	mW

### DC Electrical Characteristics (Ta=25 to 70 °C)

Parameter	Sym.	Min.	Typ.	Max.	Unit
Operating voltage	V <sub>DD</sub>	4.5	5.0	5.5	V
Operating current (with load)@33kHz	I <sub>op</sub>			5.5	mA
OSCR high input voltage	V <sub>rh</sub>	4			V
X1,X2,Y1,Y2 input reference Current	I <sub>pi</sub>	45(1v)		1500(5v)	uA
CLK,DATA positive-going threshold voltage	V <sub>t+</sub>	3.2		3.8	V
CLK,DATA negative-going threshold voltage	V <sub>t-</sub>	1.2		1.9	V
Low input voltage, other pins	V <sub>ai</sub>			1.5	V
High input voltage , other pins	V <sub>aih</sub>	3.5			V
L,M,R input current ( pull low resistor, Vin=5V )	I <sub>mi</sub>	35		45	uA
DATA, CLK input current ( pull up resistor, Vin=0V )	I <sub>dc</sub>	-0.6		-1.86	mA
DATA, CLK low output voltage ( I <sub>prl</sub> =4mA )	V <sub>prl</sub>			0.4	V
OSC IN input leakage current (Vin=5V)	I <sub>ih 0</sub>			1.0	uA
L,M,R input leakage current ( Vin =0V )	I <sub>il</sub>	-1		1	uA
X1, X2, Y1, Y2 input leakage current (Vin=0V)	I <sub>ipl</sub>	-1		1	uA



# TP8452

## PS/2 2D 3Key Mouse Controller

\* All voltages in above table are compared with  $V_{SS}$ .

\* All parameters in above table are tested under  $V_{DD}=5V$ .

\* CLK & DATA output gates are open drains that connect to pull up resistors.

### AC Electrical Characteristics (Ta=25 to 70 °C)

Parameter	Sym.	Min.	Typ.	Max.	Unit
Oscillating frequency	Fosc	32.3	38	43.7	KHz
Key debounce	Tkd		12		ms
Rising edge crossed width (Fosc=35KHz)	Tr	13.1			us
Falling edge crossed width (Fosc=35KHz)	Tf	13.1			us
Mouse CLK active time	Tmca		39.4		us
Mouse CLK inactive time	Tmci		39.4		us
Time that mouse sample	Tmdc				
DATA from CLK rising edge			13.1		us
System CLK active time	Tsca		39.4		us
System CLK inactive time	Tsci		39.4		us
Time from DATA	Tsdc				
transition to falling edge of CLK			13.1		us
Time from rising edge of	Tscd				
CLK to DATA transition			26.2		us
Time to mouse inhibit after the 11th CLK to ensure mouse does not start another transmission	Tpi	0		50	us

PS. The AC timings are measured with 38 KHz system clock signal.

TOPRO

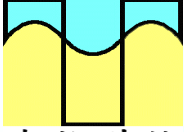

凌越科技  
Topro Technology Inc.

# TP8452

## PS/2 2D 3Key Mouse Controller

### Timing Diagram

(A) Photo-couples pulse width

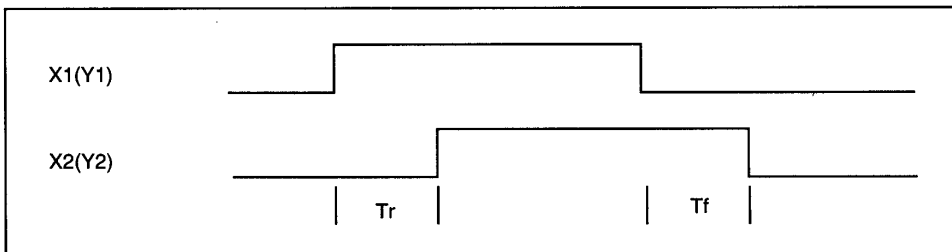

(B) Receiving Data

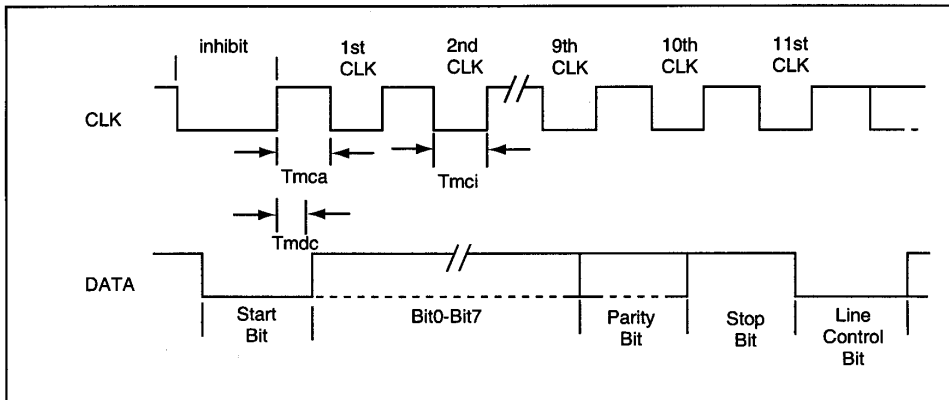

(C) Sending Data

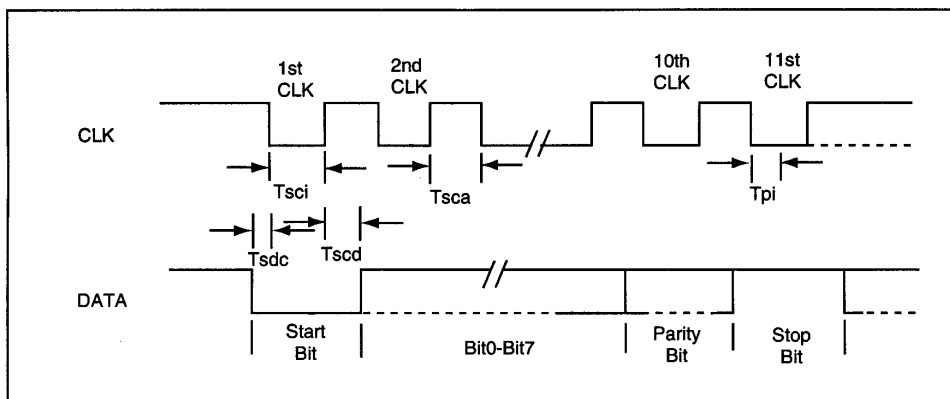

# TP8452

## *PS/2 2D 3Key Mouse Controller*

### Application Diagrams

