

R2 Series

For TO-220 and TO-247



Ohmite's R2 Series (patent pending) heatsink provides a large surface area along with our C Series clipping mechanism to attach either a TO-220 or TO-247 package. The self-aligning features of the clip assure secure attachment and enhanced thermal performance. Because no screws are required for device mounting, additional fins can be added to the rear side of the heatsink for increased total surface area in a more compact space.

FEATURES

- **Reduced Assembly Cost:** C Series camming clips make fasteners and fixtures obsolete, along with stray metal filings from tapped holes.
- **Maximum Repeatability:** clamping force of the clip is not degraded by repeated loading and unloading.
- **Maximum Heat Transfer per Unit Space:** maximum surface area per unit volume and consistent mounting force reduces thermal resistance
- **Maximum Resistance to Shock and Vibration:** light weight, resilient clips lock the component in place and are highly resistant to shock and vibration
- **Maximum Reliability:** helps prevent short circuits by eliminating metal particles from thread tapping
- **RoHS compliant**

SERIES SPECIFICATIONS

Heatsink Part Number	Surface Area (in ² /mm ²)	Weight (oz/g)	Thermal Resistance* (°C/W)
R2V-CT2-38E	21 / 13,579	5.9/26	9.8
R2A-CT2-38E	21 / 13,579	5.9/26	8.6
R2V-CT4-38E	21 / 13,579	6.4 / 29	9.8
R2A-CT4-38E	21 / 13,579	6.4 / 29	8.6

*Free convection at 15W

CHARACTERISTICS

Heat Sink	Aluminum Alloy 6063-T5 or Equivalent with either degreased or black anodized finish
Spring Clip	Music Wire, Per ASTM A228 with bright nickel plating
Solder Foot	Cold-rolled Steel, Per ASTM A-366 with pure tin over copper strike. RoHS compliant
Interface Thermal Resistance	for improvement, use thermal joint compound, 0.005 Grafoil (TGon 800 by Laird), or phase change material (Hi-Flow by Bergquist)
Insulator	(Optional) Sil-Pad 900-S, K6 800-S and K10

R2 Series

For TO-220 and TO-247

HEAT DISSIPATION

TO-247 with no thermal interface material

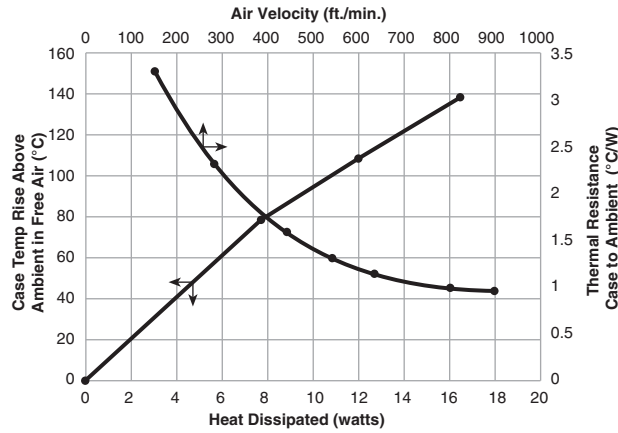

DIMENSIONS

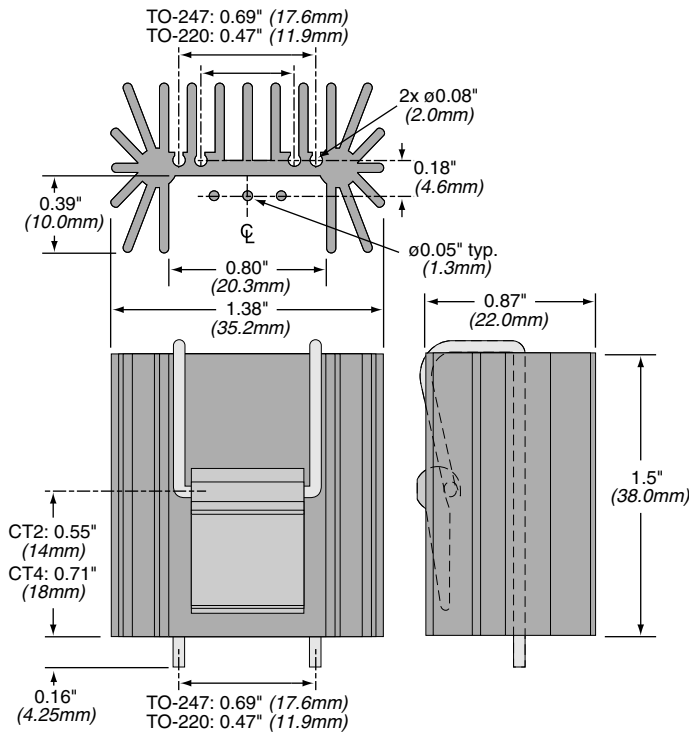

HOW TO ORDER

Series R2
 Clip C = camming clip
 RoHS Compliant
R 2 V - C T 2 - 3 8 E
 Finish A = black anodized V = degreased
 Package T2 = TO220 T4 = TO247
 Height (mm)