

TSOP
Commercial Temp
Industrial Temp

64K x 16

1Mb Asynchronous SRAM

8, 9ns
3.3V V_{DD}
Center V_{DD} & V_{SS}

Features

- Fast access time: 8, 9ns
- CMOS low power operation: 150/150 mA at min. cycle time.
- Single 3.3V ± 0.3V power supply
- All inputs and outputs are TTL compatible
- Byte control
- Fully static operation
- Industrial Temperature Option: -40° to 85°C
- Package line up
 - TP: 400mil, 44 pin TSOP Type II package

Description

The GS71216 is a high speed CMOS static RAM organized as 65,536-words by 16-bits. Static design eliminates the need for external clocks or timing strobes. Operating on a single 3.3V power supply and all inputs and outputs are TTL compatible. The GS71216 is available in a 400 mil TSOP Type-II package.

Pin Descriptions

Symbol	Description
A ₀ to A ₁₅	Address input
DQ ₁ to DQ ₁₆	Data input/output
\overline{CE}	Chip enable input
\overline{LB}	Lower byte enable input (DQ ₁ to DQ ₈)
\overline{UB}	Upper byte enable input (DQ ₉ to DQ ₁₆)
\overline{WE}	Write enable input
\overline{OE}	Output enable input
V _{DD}	+3.3V power supply
V _{SS}	Ground
NC	No connect

TSOP-II 64K x 16 Pin Configuration

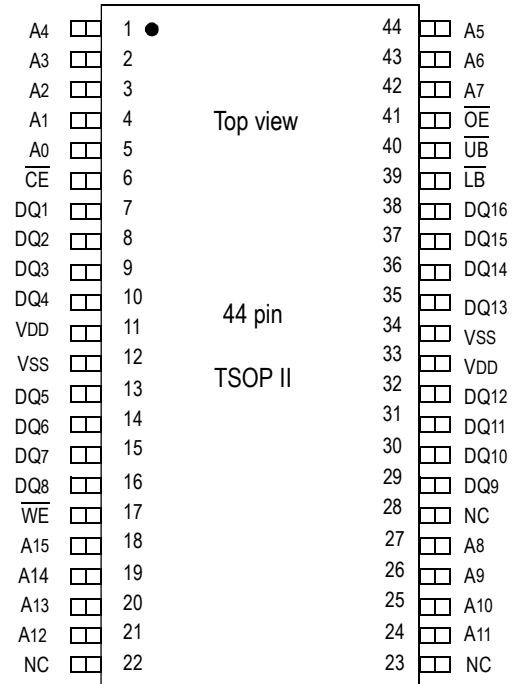

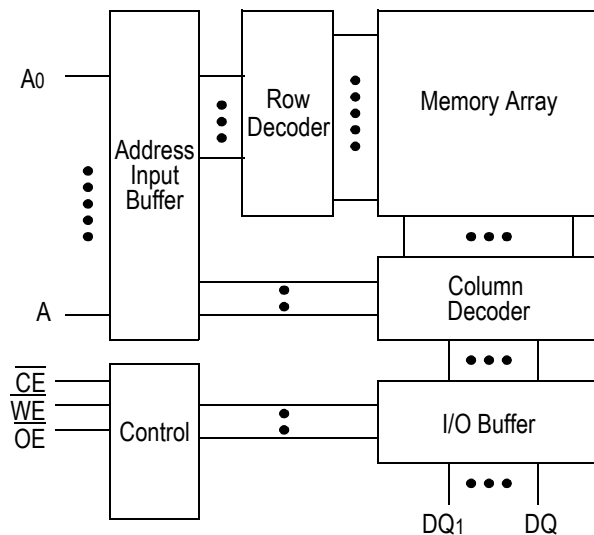
Block Diagram

Truth Table

\overline{CE}	\overline{OE}	\overline{WE}	\overline{LB}	\overline{UB}	DQ1 to DQ8	DQ9 to DQ16	VDD Current
H	X	X	X	X	Not Selected	Not Selected	ISB1, ISB2
L	L	H	L	L	Read	Read	I _{DD}
			L	H	Read	High Z	
			H	L	High Z	Read	
L	X	L	L	L	Write	Write	
			L	H	Write	Not Write, High Z	
			H	L	Not Write, High Z	Write	
L	H	H	X	X	High Z	High Z	
L	X	X	H	H	High Z	High Z	

Note: X: "H" or "L"

Absolute Maximum Ratings

Parameter	Symbol	Rating	Unit
Supply Voltage	V _{DD}	-0.5 to +4.6	V
Input Voltage	V _{IN}	-0.5 to V _{DD} +0.5 (≤ 4.6V max.)	V
Output Voltage	V _{OUT}	-0.5 to V _{DD} +0.5 (≤ 4.6V max.)	V
Allowable power dissipation	PD	0.7	W
Storage temperature	T _{STG}	-55 to 150	°C

Note:

Permanent device damage may occur if Absolute Maximum Ratings are exceeded. Functional operation shall be restricted to Recommended Operating Conditions. Exposure to higher than recommended voltages for extended periods of time could affect device reliability.

Recommended Operating Conditions

Parameter	Symbol	Min	Typ	Max	Unit
Supply Voltage for -9	V _{DD}	3.0	3.3	3.6	V
Supply Voltage for -8	V _{DD}	3.135	3.3	3.6	V
Input High Voltage	V _{IH}	2.0	-	V _{DD} +0.3	V
Input Low Voltage	V _{IL}	-0.3	-	0.8	V
Ambient Temperature, Commercial Range	T _{Ac}	0	-	70	°C
Ambient Temperature, Industrial Range	T _{AI}	-40	-	85	°C

Note:

1. Input overshoot voltage should be less than V_{DD}+2V and not exceed 20ns.
2. Input undershoot voltage should be greater than -2V and not exceed 20ns.

Capacitance

Parameter	Symbol	Test Condition	Max	Unit
Input Capacitance	C _{IN}	V _{IN} =0V	5	pF
Output Capacitance	C _{OUT}	V _{OUT} =0V	7	pF

Notes:

1. Tested at T_A=25°C, f=1MHz
2. These parameters are sampled and are not 100% tested

DC I/O Pin Characteristics

Parameter	Symbol	Test Conditions	Min	Max
Input Leakage Current	I_{IL}	$V_{IN} = 0$ to V_{DD}	-1 μ A	1 μ A
Output Leakage Current	I_{LO}	Output High Z $V_{OUT} = 0$ to V_{DD}	-1 μ A	1 μ A
Output High Voltage	V_{OH}	$I_{OH} = -4$ mA	2.4	
Output Low Voltage	V_{OL}	$I_{LO} = +4$ mA		0.4V

Power Supply Currents

Parameter	Symbol	Test Conditions	0 to 70°C		-40 to 85°C	
			8ns	9ns	8ns	9ns
Operating Supply Current	I_{DD}	$\overline{CE} \leq V_{IL}$ All other inputs $\geq V_{IH}$ or $\leq V_{IL}$ Min. cycle time $I_{OUT} = 0$ mA	150mA	150mA	160mA	160mA
Standby Current	I_{SB1}	$\overline{CE} \geq V_{IH}$ All other inputs $\geq V_{IH}$ or $\leq V_{IL}$ Min. cycle time	55mA	55mA	65mA	65mA
Standby Current	I_{SB2}	$CE \geq V_{DD} - 0.2V$ All other inputs $\geq V_{DD} - 0.2V$ or $\leq 0.2V$	15mA		25mA	

AC Test Conditions

Parameter	Conditions
Input high level	$V_{IH}=2.4V$
Input low level	$V_{IL}=0.4V$
Input rise time	$t_r=1V/ns$
Input fall time	$t_f=1V/ns$
Input reference level	1.4V
Output reference level	1.4V
Output load	Fig. 1 & 2

Note:

1. Include scope and jig capacitance.
2. Test conditions as specified with output loading as shown in Fig. 1 unless otherwise noted
3. Output load 2 for t_{LZ} , t_{HZ} , t_{OLZ} and t_{OHZ} .

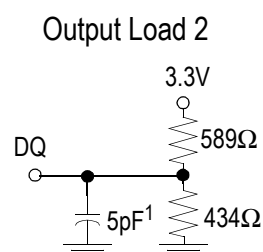
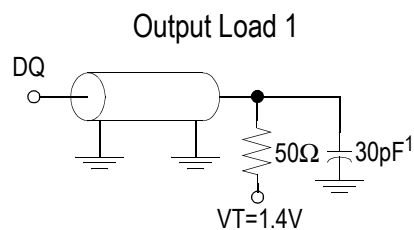

AC Characteristics
Read Cycle

Parameter	Symbol	-8		-9		Unit
		Min	Max	Min	Max	
Read cycle time	t _{RC}	8	---	9	---	ns
Address access time	t _{AA}	---	8	---	9	ns
Chip enable access time (\overline{CE})	t _{AC}	---	8	---	9	ns
Byte enable access time (\overline{UB} , \overline{LB})	t _{AB}	---	3.5	---	3.5	ns
Output enable to output valid (\overline{OE})	t _{OE}	---	3.5	---	3.5	ns
Output hold from address change	t _{OH}	3	---	3	---	ns
Chip enable to output in low Z (\overline{CE})	t _{LZ} *	3	---	3	---	ns
Output enable to output in low Z (\overline{OE})	t _{OLZ} *	0	---	0	---	ns
Byte enable to output in low Z (\overline{UB} , \overline{LB})	t _{BLZ} *	0	---	0	---	ns
Chip disable to output in High Z (\overline{CE})	t _{HZ} *	---	4	---	4	ns
Output disable to output in High Z (\overline{OE})	t _{OHZ} *	---	3.5	---	3.5	ns
Byte disable to output in High Z (\overline{UB} , \overline{LB})	t _{BHZ} *	---	3.5	---	3.5	ns

* These parameters are sampled and are not 100% tested

Read Cycle 1: $\overline{CE} = \overline{OE} = V_{IL}$, $\overline{WE} = V_{IH}$, \overline{UB} and, or $\overline{LB} = V_{IL}$

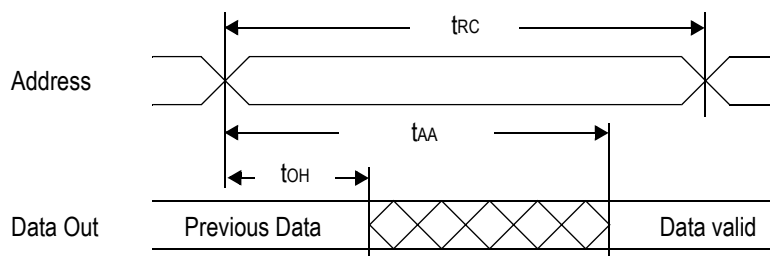

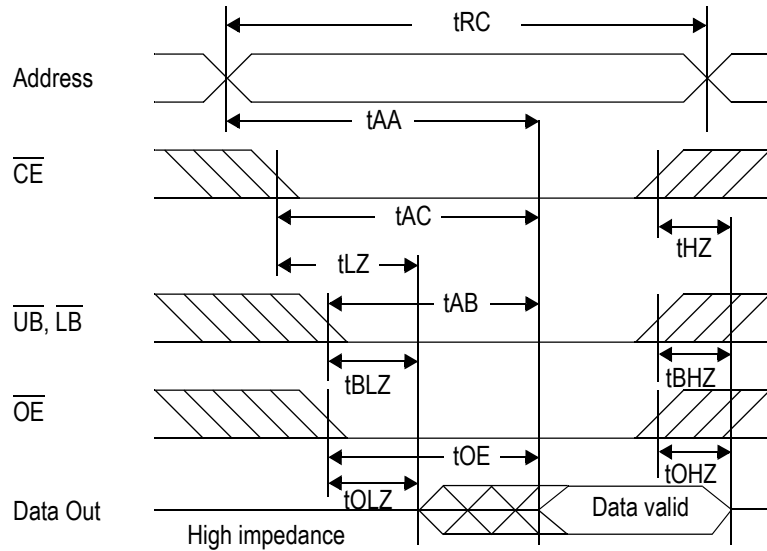
Read Cycle 2: $\overline{WE} = V_{IH}$

Write Cycle

Parameter	Symbol	-8		-9		Unit
		Min	Max	Min	Max	
Write cycle time	t_{WC}	8	---	9	---	ns
Address valid to end of write	t_{AW}	5.5	---	5.5	---	ns
Chip enable to end of write	t_{CW}	5.5	---	5.5	---	ns
Byte enable to end of write	t_{BW}	5.5	---	5.5	---	ns
Data set up time	t_{DW}	4	---	4	---	ns
Data hold time	t_{DH}	0	---	0	---	ns
Write pulse width	t_{WP}	5.5	---	5.5	---	ns
Address set up time	t_{AS}	0	---	0	---	ns
Write recovery time (\overline{WE})	t_{WR}	0	---	0	---	ns
Write recovery time (\overline{CE})	t_{WR1}	0	---	0	---	ns
Output Low Z from end of write	t_{WLZ}^*	3	---	3	---	ns
Write to output in High Z	t_{WHZ}^*	---	3.5	---	3.5	ns

* These parameters are sampled and are not 100% tested

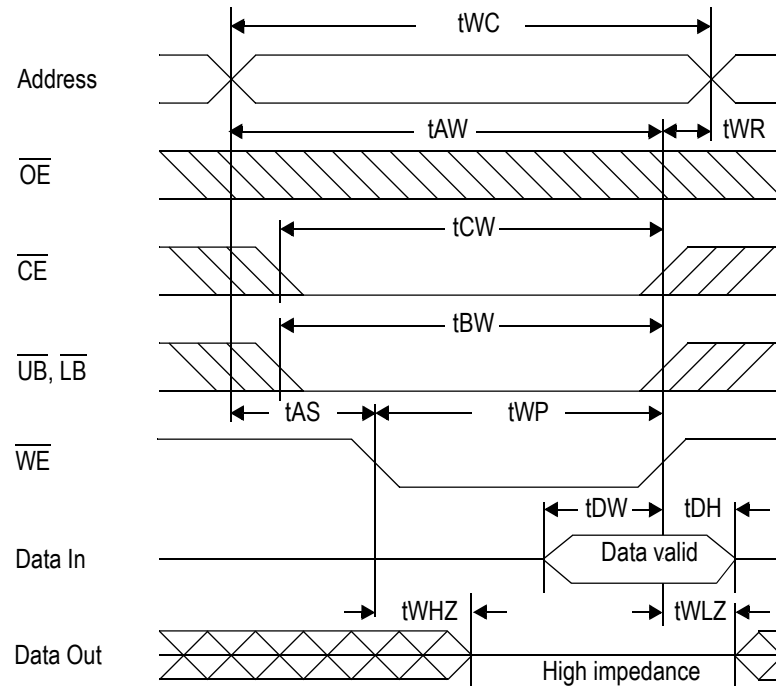
Write Cycle 1: \overline{WE} control



Write Cycle 2: \overline{CE} control

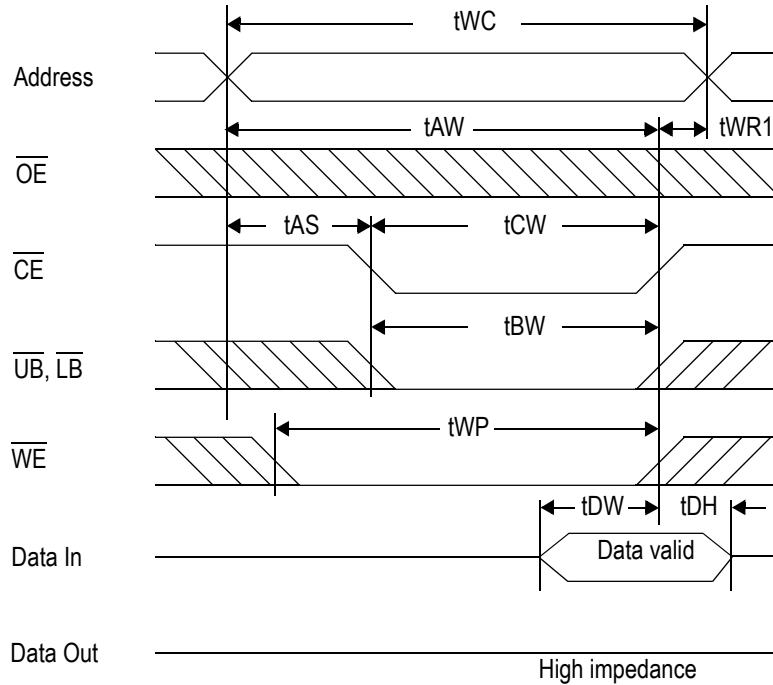

Write Cycle 3: $\overline{UB}, \overline{LB}$ control

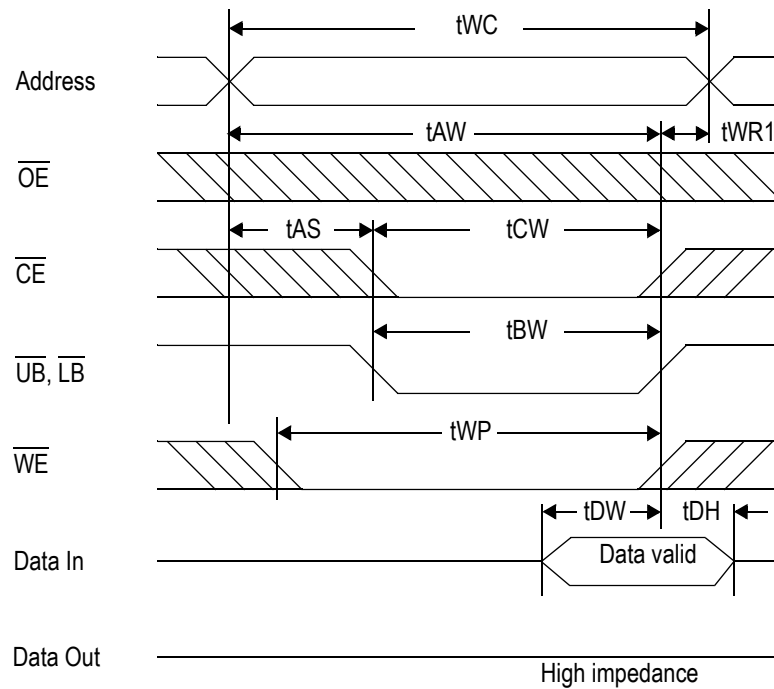

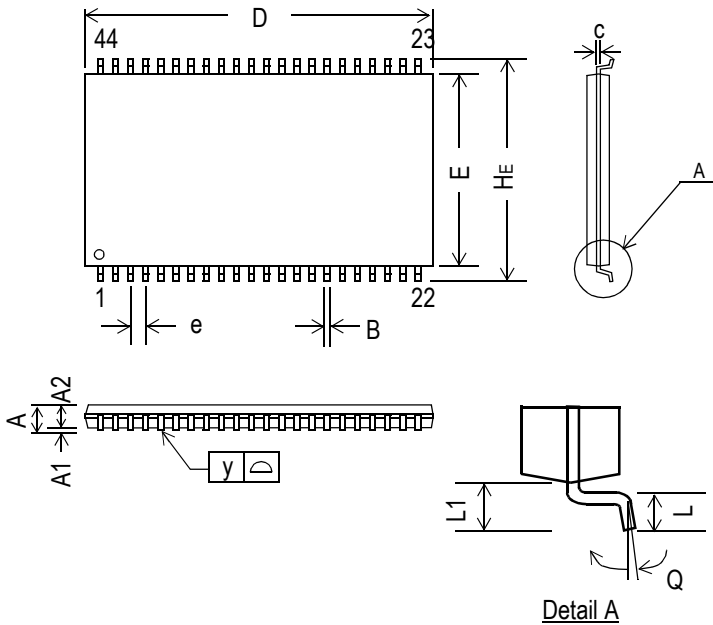
44 Pin, 400 mil TSOP-II

Symbol	Dimension in inch			Dimension in mm		
	min	nom	max	min	nom	max
A	-	-	0.047	-	-	1.20
A1	0.002	-	-	0.05	-	-
A2	0.037	0.039	0.041	0.95	1.00	1.05
B	0.01	0.014	0.018	0.25	0.35	0.45
c	-	0.006	-	-	0.15	-
D	0.721	0.725	0.729	18.31	18.41	18.51
E	0.396	0.400	0.404	10.06	10.16	10.26
e	-	0.031	-	-	0.80	-
HE	0.455	0.463	0.471	11.56	11.76	11.96
L	0.016	0.020	0.024	0.40	0.50	0.60
L1	-	0.031	-	-	0.80	-
y	-	-	0.004	-	-	0.10
Q	0°	-	5°	0°	-	5°

Note:

1. Dimension D & E do not include interlead flash
2. Dimension B does not include dambar protrusion / intrusion
3. Controlling dimension: mm

Ordering Information

Part Number [*]	Package	Access Time	Temp. Range	Status
GS71216TP-8	400 mil TSOP-II	8 ns	Commercial	
GS71216TP-10	400 mil TSOP-II	9 ns	Commercial	
GS71216TP-8I	400 mil TSOP-II	8 ns	Industrial	
GS71216TP-10I	400 mil TSOP-II	9 ns	Industrial	

^{*} Customers requiring delivery in Tape and Reel should add the character "T" to the end of the part number. For example: GS71216TP-8T

