

REVISIONS																	
LTR	DESCRIPTION										DATE (YR-MO-DA)			APPROVED			
REV																	
SHEET																	
REV																	
SHEET																	
REV STATUS OF SHEETS		REV SHEET		1	2	3	4	5	6	7	8	9	10	11	12	13	14
PMIC N/A		PREPARED BY Rajesh Pithadia					DEFENSE SUPPLY CENTER COLUMBUS COLUMBUS, OHIO 43216										
STANDARD MICROCIRCUIT DRAWING THIS DRAWING IS AVAILABLE FOR USE BY ALL DEPARTMENTS AND AGENCIES OF THE DEPARTMENT OF DEFENSE AMSC N/A		CHECKED BY Rajesh Pithadia															
		APPROVED BY Raymond Monnin															
		DRAWING APPROVAL DATE 98-05-28															
		REVISION LEVEL															
					SIZE A	CAGE CODE 67268	5962-88512										
					SHEET		1 OF 14										

DSCC FORM 2233
APR 97

5962-E347-98

DISTRIBUTION STATEMENT A. Approved for public release; distribution is unlimited.

9004708 0036022 310

1. SCOPE

1.1 Scope. This drawing documents two product assurance class levels consisting of high reliability (device classes Q and M) and space application (device class V). A choice of case outlines and lead finishes are available and are reflected in the Part or Identifying Number (PIN). When available, a choice of Radiation Hardness Assurance (RHA) levels are reflected in the PIN.

1.2 PIN. The PIN is as shown in the following example:

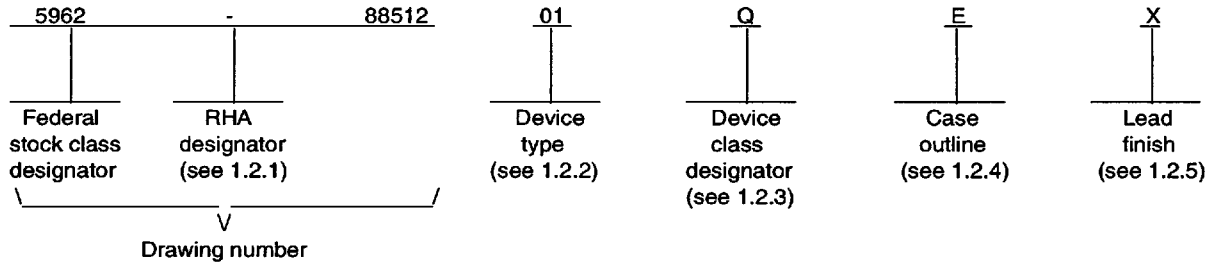

1.2.1 RHA designator. Device classes Q and V RHA marked devices meet the MIL-PRF-38535 specified RHA levels and are marked with the appropriate RHA designator. Device class M RHA marked devices meet the MIL-PRF-38535, appendix A specified RHA levels and are marked with the appropriate RHA designator. A dash (-) indicates a non-RHA device.

1.2.2 Device type(s). The device type(s) identify the circuit function as follows:

<u>Device type</u>	<u>Generic number</u>	<u>Circuit function</u>
01	55138	Quaduple bus transceiver

1.2.3 Device class designator. The device class designator is a single letter identifying the product assurance level as follows:

<u>Device class</u>	<u>Device requirements documentation</u>
M	Vendor self-certification to the requirements for MIL-STD-883 compliant, non-JAN class level B microcircuits in accordance with MIL-PRF-38535, appendix A
Q or V	Certification and qualification to MIL-PRF-38535

1.2.4 Case outline(s). The case outline(s) are as designated in MIL-STD-1835 and as follows:

<u>Outline letter</u>	<u>Descriptive designator</u>	<u>Terminals</u>	<u>Package style</u>
E	GDIP1-T16 or CDIP2-T16	16	Dual-in-line

1.2.5 Lead finish. The lead finish is as specified in MIL-PRF-38535 for device classes Q and V or MIL-PRF-38535, appendix A for device class M.

STANDARD MICROCIRCUIT DRAWING DEFENSE SUPPLY CENTER COLUMBUS COLUMBUS, OHIO 43216-5000	SIZE A		5962-88512
		REVISION LEVEL	SHEET 2

DSCC FORM 2234
APR 97

■ 9004708 0036023 257 ■

1.3 Absolute maximum ratings. 1/

Supply voltage (V _{CC}) 2/	7 V
Input voltage (V _{IN})	5.5 V
Driver off-state output voltage	7 V
Low-level output current into the driver output	150 mA
Continuous total power dissipation (P _D)	1375 mW 3/
Storage temperature range.....	-65°C to +125°C
Lead temperature 1.6 mm (1/16 inch) from case for 60 seconds.....	300°C

1.4 Recommended operating conditions.

Supply voltage range (V _{CC}).....	4.5 V to 5.5 V
High-level input voltage (V _{IH}):	
Driver or strobe	2 V minimum
Receiver	3.2 V minimum
Low-level input voltage (V _{IL}):	
Driver or strobe	0.8 V maximum
Receiver	1.5 V maximum
High-level output current, (I _{OH}):	
Receiver output.....	-400 μA
Low-level output current (I _{OL}):	
Driver output.....	100 mA
Receiver output.....	16 mA
Ambient operating temperature range (T _A)	-55°C to +125°C

2. APPLICABLE DOCUMENTS

2.1 Government specification, standards, and handbooks. The following specification, standards, and handbooks form a part of this drawing to the extent specified herein. Unless otherwise specified, the issues of these documents are those listed in the issue of the Department of Defense Index of Specifications and Standards (DoDISS) and supplement thereto, cited in the solicitation.

SPECIFICATION

DEPARTMENT OF DEFENSE

MIL-PRF-38535 - Integrated Circuits, Manufacturing, General Specification for.

STANDARDS

DEPARTMENT OF DEFENSE

- MIL-STD-883 - Test Method Standard Microcircuits.
- MIL-STD-973 - Configuration Management.
- MIL-STD-1835 - Interface Standard For Microcircuit Case Outlines.

1/ Stresses above the absolute maximum rating may cause permanent damage to the device. Extended operation at the maximum levels may degrade performance and affect reliability.

2/ All voltage values are with respect to both ground terminals connected together.

3/ For operation above T_A = 25°C, the derating factor for case E is 11.0 mW/°C.

STANDARD MICROCIRCUIT DRAWING DEFENSE SUPPLY CENTER COLUMBUS COLUMBUS, OHIO 43216-5000	SIZE A		5962-88512
		REVISION LEVEL	SHEET 3

DSCC FORM 2234
APR 97

■ 9004708 0036024 193 ■

HANDBOOKS

DEPARTMENT OF DEFENSE

- MIL-HDBK-103 - List of Standard Microcircuit Drawings (SMD's).
- MIL-HDBK-780 - Standard Microcircuit Drawings.

(Unless otherwise indicated, copies of the specification, standards, and handbooks are available from the Standardization Document Order Desk, 700 Robbins Avenue, Building 4D, Philadelphia, PA 19111-5094.)

2.2 Order of precedence. In the event of a conflict between the text of this drawing and the references cited herein, the text of this drawing takes precedence. Nothing in this document, however, supersedes applicable laws and regulations unless a specific exemption has been obtained.

3. REQUIREMENTS

3.1 Item requirements. The individual item requirements for device classes Q and V shall be in accordance with MIL-PRF-38535 and as specified herein or as modified in the device manufacturer's Quality Management (QM) plan. The modification in the QM plan shall not affect the form, fit, or function as described herein. The individual item requirements for device class M shall be in accordance with MIL-PRF-38535, appendix A for non-JAN class level B devices and as specified herein.

3.2 Design, construction, and physical dimensions. The design, construction, and physical dimensions shall be as specified in MIL-PRF-38535 and herein for device classes Q and V or MIL-PRF-38535, appendix A and herein for device class M.

3.2.1 Case outline(s). The case outline(s) shall be in accordance with 1.2.4 herein.

3.2.2 Terminal connections. The terminal connections shall be as specified on figure 1.

3.2.3 Truth table(s). The truth table(s) shall be as specified on figure 2.

3.2.4 Logic diagram(s). The logic diagram(s) shall be as specified on figure 3.

3.3 Electrical performance characteristics and postirradiation parameter limits. Unless otherwise specified herein, the electrical performance characteristics and postirradiation parameter limits are as specified in table I and shall apply over the full ambient operating temperature range.

3.4 Electrical test requirements. The electrical test requirements shall be the subgroups specified in table II. The electrical tests for each subgroup are defined in table I.

3.5 Marking. The part shall be marked with the PIN listed in 1.2 herein. In addition, the manufacturer's PIN may also be marked as listed in MIL-HDBK-103. For packages where marking of the entire SMD PIN number is not feasible due to space limitations, the manufacturer has the option of not marking the "5962-" on the device. For RHA product using this option, the RHA designator shall still be marked. Marking for device classes Q and V shall be in accordance with MIL-PRF-38535. Marking for device class M shall be in accordance with MIL-PRF-38535, appendix A.

3.5.1 Certification/compliance mark. The certification mark for device classes Q and V shall be a "QML" or "Q" as required in MIL-PRF-38535. The compliance mark for device class M shall be a "C" as required in MIL-PRF-38535, appendix A.

STANDARD MICROCIRCUIT DRAWING DEFENSE SUPPLY CENTER COLUMBUS COLUMBUS, OHIO 43216-5000	SIZE A		5962-88512
		REVISION LEVEL	SHEET 4

DSCC FORM 2234
APR 97

■ 9004708 0036025 02T ■

TABLE I. Electrical performance characteristics.

Test		Symbol	Conditions <u>1/</u> -55°C ≤ T _A ≤ +125°C unless otherwise specified	Group A subgroups	Device type	Limits		Unit
						Min	Max	
Input clamp voltage	Driver or strobe	V _{IK}	V _{CC} = 4.5 V, I _{IN} = -12 mA	1, 2, 3	01		-1.5	V
High-level output voltage	Receiver	V _{OH}	V _{CC} = 4.5 V, V _{IH(S)} = 2 V, V _{IL(R)} = 1.5 V, I _{OH} = -400 μA	1, 2, 3	01	2.4		V
Low-level output voltage	Driver	V _{OL}	V _{CC} = 4.5 V, V _{IH(D)} = 2 V, V _{IL(S)} = 0.8 V, I _{OL} = 100 mA	1, 2, 3	01		0.45	V
	Receiver		V _{CC} = 4.5 V, V _{IH(R)} = 3.2 V, V _{IH(S)} = 2 V, I _{OL} = 16 mA				0.4	
Input current at maximum input voltage	Driver or strobe	I _{I(max)}	V _{CC} = 5.5 V, V _{IN} = V _{CC}	1, 2, 3	01		1	mA
High -level input current	Driver or strobe	I _{IH}	V _{CC} = 5.5 V, V _{IN} = 2.4 V	1, 2, 3	01	40		μA
	Receiver		V _{CC} = 5 V, V _{IN(R)} = 4.5 V, V _{IN(S)} = 2 V			300		
Low-level input current	Driver or strobe	I _{IL}	V _{CC} = 5.5 V, V _{IN} = 0.4 V	1, 2, 3	01		-1.6	mA
	Receiver		V _{CC} = 5 V, V _{IN(R)} = 0.45 V, V _{IN(S)} = 2 V				-50	μA
Input current with power off	Receiver	I _{I(off)}	V _{CC} = 0 V, V _{IN} = 4.5 V	1, 2, 3	01		1.5	mA
Short-circuit output current <u>2/</u>	Receiver	I _{OS}	V _{CC} = 5.5 V	1, 2, 3	01	-20	-55	mA

See footnotes at end of table.

STANDARD MICROCIRCUIT DRAWING DEFENSE SUPPLY CENTER COLUMBUS COLUMBUS, OHIO 43216-5000	SIZE A		5962-88512
		REVISION LEVEL	SHEET 5

DSCC FORM 2234
APR 97

■ 9004708 0036026 T66 ■

TABLE I. Electrical performance characteristics - Continued.

Test	Symbol	Conditions ^{1/} -55°C ≤ T _A ≤ +125°C unless otherwise specified	Group A subgroups	Device type	Limits		Unit	
					Min	Max		
Supply current	All driver outputs low	I _{CC}	V _{CC} = 5.5 V, V _{IN(D)} = 2 V, V _{IN(S)} = 0.8 V	1, 2, 3	01		65	mA
	All driver outputs high					V _{CC} = 5.5 V, V _{IN(R)} = 3.5 V, V _{IN(S)} = 2 V, Receiver outputs open		
Functional test	<u>3/</u>	See 4.4.1b	7, 8A, 8B	01	L	H		
Propagation delay time from driver to driver	t _{PLH}	R _L = 50 Ω, C _L = 50 pF See figure 4	9	01		24	ns	
	t _{PHL}					24		
Propagation delay time from strobe to driver	t _{PLH}	R _L = 50 Ω, C _L = 50 pF See figure 4	9	01		28	ns	
	t _{PHL}					32		
Propagation delay time from receiver to receiver	t _{PLH}	R _L = 400 Ω, C _L = 15 pF See figure 4	9	01		15	ns	
	t _{PHL}					15		

^{1/} Parenthetical letters D, R, and S used with V_{IN} refer to the driver input, receiver input, and strobe input, respectively.

^{2/} Not more than one output should be shorted at a time.

^{3/} Tests shall be performed in sequence, attributes data only. Functional tests shall include the truth table and other logic patterns used for fault detection. The test vectors used to verify the truth table shall, at a minimum, test all functions of each input and output. All possible input to output logic patterns per function shall be guaranteed, if not tested, to the truth table in figure 2 herein. Functional tests shall be performed in sequence as approved by the qualifying activity on qualified devices.

STANDARD MICROCIRCUIT DRAWING DEFENSE SUPPLY CENTER COLUMBUS COLUMBUS, OHIO 43216-5000	SIZE A		5962-88512
		REVISION LEVEL	SHEET 6

DSCC FORM 2234
APR 97

■ 9004708 0036027 9T2 ■

Device type	01
Case outline	E
Terminal number	Terminal symbol
1	GND
2	1B
3	1R
4	1D
5	2D
6	2R
7	2B
8	GND
9	3B
10	3R
11	3D
12	S
13	4D
14	4R
15	4B
16	V _{cc}

FIGURE 1. Terminal connections.

STANDARD MICROCIRCUIT DRAWING DEFENSE SUPPLY CENTER COLUMBUS COLUMBUS, OHIO 43216-5000	SIZE A		5962-88512
		REVISION LEVEL	SHEET 7

DSCC FORM 2234
APR 97

■ 9004708 0036028 839 ■

TRANSMITTING

INPUTS		OUTPUTS	
S	D	B	R
L	H	L	H
L	L	H	L

RECEIVING

INPUTS			OUTPUT
S	B	D	R
H	H	X	L
H	L	X	H

H = High level, L = Low level, X = Don't care

FIGURE 2. Truth table.

STANDARD MICROCIRCUIT DRAWING DEFENSE SUPPLY CENTER COLUMBUS COLUMBUS, OHIO 43216-5000	SIZE A		5962-88512
		REVISION LEVEL	SHEET 8

DSCC FORM 2234
APR 97

■ 9004708 0036029 775 ■

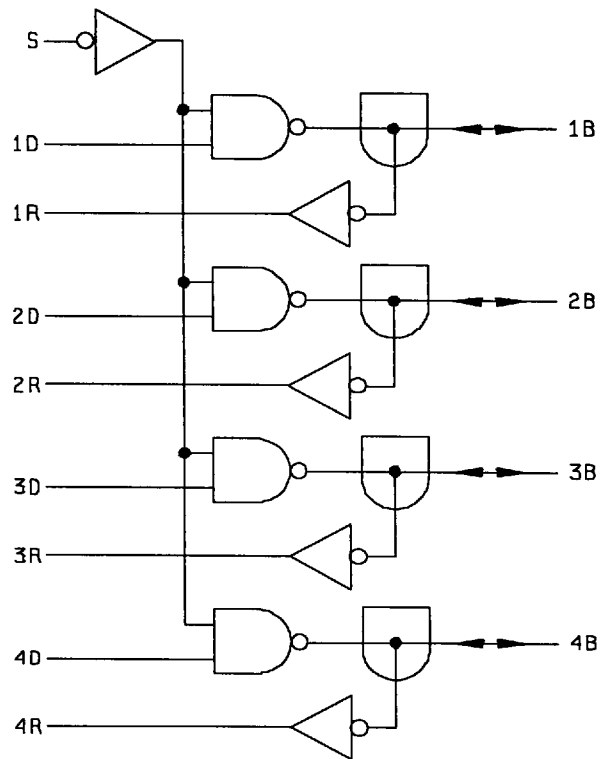

FIGURE 3. Logic diagram.

**STANDARD
MICROCIRCUIT DRAWING**
DEFENSE SUPPLY CENTER COLUMBUS
COLUMBUS, OHIO 43216-5000

SIZE
A

5962-88512

REVISION LEVEL

SHEET

9

DSCC FORM 2234
APR 97

■ 9004708 0036030 497 ■

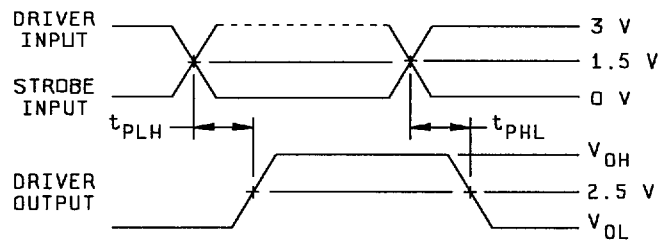
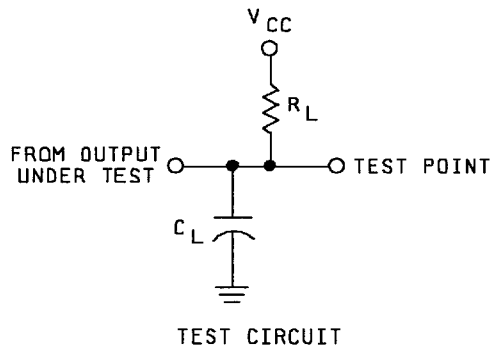

Notes:

1. Input pulses are supplied by generators having the following characteristics: $t_w = 100$ ns, $PRR \leq 1$ MHz, $t_r \leq 10$ ns, $t_f \leq 10$ ns, $Z_o \approx 50 \Omega$.
2. C_L includes probe and jig capacitance.
3. When testing driver input (solid line) strobe must be low; when testing strobe input (dashed line) driver input must be high.

FIGURE 4. Switching waveforms and test circuit.

STANDARD MICROCIRCUIT DRAWING DEFENSE SUPPLY CENTER COLUMBUS COLUMBUS, OHIO 43216-5000	SIZE A		5962-88512
		REVISION LEVEL	SHEET 10

DSCC FORM 2234
APR 97

■ 9004708 0036031 323 ■

3.6 Certificate of compliance. For device classes Q and V, a certificate of compliance shall be required from a QML-38535 listed manufacturer in order to supply to the requirements of this drawing (see 6.6.1 herein). For device class M, a certificate of compliance shall be required from a manufacturer in order to be listed as an approved source of supply in MIL-HDBK-103 (see 6.6.2 herein). The certificate of compliance submitted to DSCC-VA prior to listing as an approved source of supply for this drawing shall affirm that the manufacturer's product meets, for device classes Q and V, the requirements of MIL-PRF-38535 and herein or for device class M, the requirements of MIL-PRF-38535, appendix A and herein.

3.7 Certificate of conformance. A certificate of conformance as required for device classes Q and V in MIL-PRF-38535 or for device class M in MIL-PRF-38535, appendix A shall be provided with each lot of microcircuits delivered to this drawing.

3.8 Notification of change for device class M. For device class M, notification to DSCC-VA of change of product (see 6.2 herein) involving devices acquired to this drawing is required for any change as defined in MIL-STD-973.

3.9 Verification and review for device class M. For device class M, DSCC, DSCC's agent, and the acquiring activity retain the option to review the manufacturer's facility and applicable required documentation. Offshore documentation shall be made available onshore at the option of the reviewer.

3.10 Microcircuit group assignment for device class M. Device class M devices covered by this drawing shall be in microcircuit group number 53 (see MIL-PRF-38535, appendix A).

4. QUALITY ASSURANCE PROVISIONS

4.1 Sampling and inspection. For device classes Q and V, sampling and inspection procedures shall be in accordance with MIL-PRF-38535 or as modified in the device manufacturer's Quality Management (QM) plan. The modification in the QM plan shall not affect the form, fit, or function as described herein. For device class M, sampling and inspection procedures shall be in accordance with MIL-PRF-38535, appendix A.

4.2 Screening. For device classes Q and V, screening shall be in accordance with MIL-PRF-38535, and shall be conducted on all devices prior to qualification and technology conformance inspection. For device class M, screening shall be in accordance with method 5004 of MIL-STD-883, and shall be conducted on all devices prior to quality conformance inspection.

4.2.1 Additional criteria for device class M.

a. Burn-in test, method 1015 of MIL-STD-883.

(1) Test condition A, B, C, or D. The test circuit shall be maintained by the manufacturer under document revision level control and shall be made available to the preparing or acquiring activity upon request. The test circuit shall specify the inputs, outputs, biases, and power dissipation, as applicable, in accordance with the intent specified in test method 1015.

(2) $T_A = +125^\circ\text{C}$, minimum.

b. Interim and final electrical test parameters shall be as specified in table II herein.

STANDARD MICROCIRCUIT DRAWING DEFENSE SUPPLY CENTER COLUMBUS COLUMBUS, OHIO 43216-5000	SIZE A		5962-88512
		REVISION LEVEL	SHEET 11

DSCC FORM 2234
APR 97

■ 9004708 0036032 26T ■

TABLE II. Electrical test requirements.

Test requirements	Subgroups (in accordance with MIL-STD-883, method 5005, table I)	Subgroups (in accordance with MIL-PRF-38535, table III)	
	Device class M	Device class Q	Device class V
Interim electrical parameters (see 4.2)	---	---	1
Final electrical parameters (see 4.2)	1, 2, 3, 7, 8A, 8B, 9 1/	1, 2, 3, 7, 8A, 8B, 9 1/	1, 2, 3, 7, 8A, 8B, 9 2/
Group A test requirements (see 4.4)	1, 2, 3, 7, 8A, 8B, 9	1, 2, 3, 7, 8A, 8B, 9	1, 2, 3, 7, 8A, 8B, 9
Group C end-point electrical parameters (see 4.4)	1, 2, 3	1, 2, 3	1, 2, 3
Group D end-point electrical parameters (see 4.4)	1, 2, 3	1, 2, 3	1, 2, 3
Group E end-point electrical parameters (see 4.4)	1, 7, 9	1, 7, 9	1, 7, 9

1/ PDA applies to subgroup 1.

2/ PDA applies to subgroups 1 and 7.

4.2.2 Additional criteria for device classes Q and V.

- a. The burn-in test duration, test condition and test temperature, or approved alternatives shall be as specified in the device manufacturer's QM plan in accordance with MIL-PRF-38535. The burn-in test circuit shall be maintained under document revision level control of the device manufacturer's Technology Review Board (TRB) in accordance with MIL-PRF-38535 and shall be made available to the acquiring or preparing activity upon request. The test circuit shall specify the inputs, outputs, biases, and power dissipation, as applicable, in accordance with the intent specified in test method 1015 of MIL-STD-883.
- b. Interim and final electrical test parameters shall be as specified in table II herein.
- c. Additional screening for device class V beyond the requirements of device class Q shall be as specified in MIL-PRF-38535, appendix B.

4.3 Qualification inspection for device classes Q and V. Qualification inspection for device classes Q and V shall be in accordance with MIL-PRF-38535. Inspections to be performed shall be those specified in MIL-PRF-38535 and herein for groups A, B, C, D, and E inspections (see 4.4.1 through 4.4.4).

STANDARD MICROCIRCUIT DRAWING DEFENSE SUPPLY CENTER COLUMBUS COLUMBUS, OHIO 43216-5000	SIZE A		5962-88512
		REVISION LEVEL	SHEET 12

DSCC FORM 2234
APR 97

■ 9004708 0036033 176 ■

4.4 Conformance inspection. Technology conformance inspection for classes Q and V shall be in accordance with MIL-PRF-38535 including groups A, B, C, D, and E inspections and as specified herein except where option 2 of MIL-PRF-38535 permits alternate in-line control testing. Quality conformance inspection for device class M shall be in accordance with MIL-PRF-38535, appendix A and as specified herein. Inspections to be performed for device class M shall be those specified in method 5005 of MIL-STD-883 and herein for groups A, B, C, D, and E inspections (see 4.4.1 through 4.4.4).

4.4.1 Group A inspection.

- a. Tests shall be as specified in table II herein.
- b. For device class M, subgroups 7 and 8 tests shall be sufficient to verify the truth table. For device classes Q and V, subgroups 7 and 8 shall include verifying the functionality of the device.
- c. Subgroups 4, 5, 6, 10, and 11 in table I, method 5005 of MIL-STD-883 shall be omitted.

4.4.2 Group C inspection. The group C inspection end-point electrical parameters shall be as specified in table II herein.

4.4.2.1 Additional criteria for device class M. Steady-state life test conditions, method 1005 of MIL-STD-883:

- a. Test condition A, B, C or D. The test circuit shall be maintained by the manufacturer under document revision level control and shall be made available to the preparing or acquiring activity upon request. The test circuit shall specify the inputs, outputs, biases, and power dissipation, as applicable, in accordance with the intent specified in test method 1005 of MIL-STD-883.
- b. $T_A = +125^\circ\text{C}$, minimum.
- c. Test duration: 1,000 hours, except as permitted by method 1005 of MIL-STD-883.

4.4.2.2 Additional criteria for device classes Q and V. The steady-state life test duration, test condition and test temperature, or approved alternatives shall be as specified in the device manufacturer's QM plan in accordance with MIL-PRF-38535. The test circuit shall be maintained under document revision level control by the device manufacturer's TRB in accordance with MIL-PRF-38535 and shall be made available to the acquiring or preparing activity upon request. The test circuit shall specify the inputs, outputs, biases, and power dissipation, as applicable, in accordance with the intent specified in test method 1005 of MIL-STD-883.

4.4.3 Group D inspection. The group D inspection end-point electrical parameters shall be as specified in table II herein.

4.4.4 Group E inspection. Group E inspection is required only for parts intended to be marked as radiation hardness assured (see 3.5 herein).

- a. End-point electrical parameters shall be as specified in table II herein.
- b. For device classes Q and V, the devices or test vehicle shall be subjected to radiation hardness assured tests as specified in MIL-PRF-38535 for the RHA level being tested. For device class M, the devices shall be subjected to radiation hardness assured tests as specified in MIL-PRF-38535, appendix A for the RHA level being tested. All device classes must meet the postirradiation end-point electrical parameter limits as defined in table I at $T_A = +25^\circ\text{C} \pm 5^\circ\text{C}$, after exposure, to the subgroups specified in table II herein.
- c. When specified in the purchase order or contract, a copy of the RHA delta limits shall be supplied.

5. PACKAGING

5.1 Packaging requirements. The requirements for packaging shall be in accordance with MIL-PRF-38535 for device classes Q and V or MIL-PRF-38535, appendix A for device class M.

STANDARD MICROCIRCUIT DRAWING DEFENSE SUPPLY CENTER COLUMBUS COLUMBUS, OHIO 43216-5000	SIZE A		5962-88512
		REVISION LEVEL	SHEET 13

DSCC FORM 2234
APR 97

■ 9004708 0036034 032 ■

6. NOTES

6.1 Intended use. Microcircuits conforming to this drawing are intended for use for Government microcircuit applications (original equipment), design applications, and logistics purposes.

6.1.1 Replaceability. Microcircuits covered by this drawing will replace the same generic device covered by a contractor prepared specification or drawing.

6.1.2 Substitutability. Device class Q devices will replace device class M devices.

6.2 Configuration control of SMD's. All proposed changes to existing SMD's will be coordinated with the users of record for the individual documents. This coordination will be accomplished in accordance with MIL-STD-973 using DD Form 1692, Engineering Change Proposal.

6.3 Record of users. Military and industrial users should inform Defense Supply Center Columbus when a system application requires configuration control and which SMD's are applicable to that system. DSCC will maintain a record of users and this list will be used for coordination and distribution of changes to the drawings. Users of drawings covering microelectronic devices (FSC 5962) should contact DSCC-VA, telephone (614) 692-0525.

6.4 Comments. Comments on this drawing should be directed to DSCC-VA , Columbus, Ohio 43216-5000, or telephone (614) 692-0674.

6.5 Abbreviations, symbols, and definitions. The abbreviations, symbols, and definitions used herein are defined in MIL-PRF-38535 and MIL-HDBK-1331.

6.6 Sources of supply.

6.6.1 Sources of supply for device classes Q and V. Sources of supply for device classes Q and V are listed in QML-38535. The vendors listed in QML-38535 have submitted a certificate of compliance (see 3.6 herein) to DSCC-VA and have agreed to this drawing.

6.6.2 Approved sources of supply for device class M. Approved sources of supply for class M are listed in MIL-HDBK-103. The vendors listed in MIL-HDBK-103 have agreed to this drawing and a certificate of compliance (see 3.6 herein) has been submitted to and accepted by DSCC-VA.

STANDARD MICROCIRCUIT DRAWING DEFENSE SUPPLY CENTER COLUMBUS COLUMBUS, OHIO 43216-5000	SIZE A		5962-88512
		REVISION LEVEL	SHEET 14

DSCC FORM 2234
APR 97

■ 9004708 0036035 T79 ■

STANDARD MICROCIRCUIT DRAWING BULLETIN

DATE: 98-05-28

Approved sources of supply for SMD 5962-88512 are listed below for immediate acquisition information only and shall be added to MIL-HDBK-103 and QML-38535 during the next revision. MIL-HDBK-103 and QML-38535 will be revised to include the addition or deletion of sources. The vendors listed below have agreed to this drawing and a certificate of compliance has been submitted to and accepted by DSCC-VA. This bulletin is superseded by the next dated revision of MIL-HDBK-103 and QML-38535.

Standard microcircuit drawing PIN <u>1/</u>	Vendor CAGE number	Vendor similar PIN <u>2/</u>
5962-8851201QEA	01295	SNJ55138J

1/ The lead finish shown for each PIN representing a hermetic package is the most readily available from the manufacturer listed for that part. If the desired lead finish is not listed contact the vendor to determine its availability.

2/ **Caution.** Do not use this number for item acquisition. Items acquired to this number may not satisfy the performance requirements of this drawing.

Vendor CAGE
number

01295

Vendor name
and address

Texas Instruments Incorporated
13500 N. Central Expressway
P.O. Box 655303
Dallas, TX 75265
Point of contact: I-20 at FM 1788
Midland, TX 79711-0448

The information contained herein is disseminated for convenience only and the Government assumes no liability whatsoever for any inaccuracies in the information bulletin.

■ 9004708 0036036 905 ■