

ISOLATED DC/DC CONVERTERS

36 Vdc - 75 Vdc Input 12 Vdc /25 A Output, 1/4 Brick



March 27, 2009

Bel Power, Inc. , a subsidiary of Bel Fuse, Inc.

0RQB-T0T12x

RoHS Compliant

Rev.C

Features

- Isolated
- High Efficiency
- High Power Density
- Fixed Frequency (250 kHz)
- Low Cost
- Input Under-Voltage Lockout
- Basic Insulation
- Class 1, Category 2, Isolated DC/DC Converter (refer to IPC-9592)
- TUV EN60950-1 Recognized (Pending)
- UL60950-1 Recognized (UL/cUL) (Pending)
- Output Over-Voltage Shutdown
- Output Voltage Trim
- OCP/SCP
- Over Temperature Protection
- Remote On/Off
- Positive/Negative Remote Sense

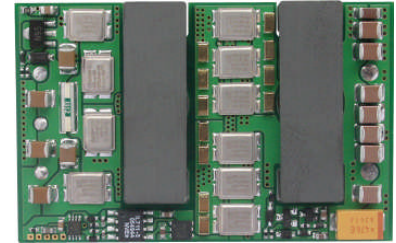

Applications

- Networking
- Computers and peripherals
- Telecommunications

Description

The 0RQB-T0T12X is an isolated dc/dc converter that operates from a nominal 48 Vdc source. This unit will provide up to 300 W of output power from a nominal 48 Vdc input. This unit is designed to be highly efficient and low cost. Features include remote on/off, over current protection and under voltage lockout. The converter is provided in an industry standard quarter brick package.

Part Selection

Output Voltage	Input Voltage	Max. Output Current	Max. Output Power	Typical Efficiency	Model Number Active High	Model Number Active Low
12 Vdc	36 Vdc - 75 Vdc	25 A	300 W	95.5%	0RQB-T0T120	0RQB-T0T12L

Notes: Add "G" suffix at the end of the model number to indicate Tray Packaging.

Part Number Explanation

$\frac{0}{1} \frac{R}{2} \frac{QB}{3} - \frac{T0}{4} \frac{T}{5} \frac{12}{6} \frac{0}{7}$

1---Through hole

2---RoHS 6, change "R" to "7" means RoHS 5

3---Series name, 1/4 Brick

4---Series code

5---Input range 48V wide (36-75V)

6---Output voltage 12V

7---Remote sense, active high, change "0" to "L" means active low

ISOLATED DC/DC CONVERTERS

36 Vdc - 75 Vdc Input 12 Vdc /25 A Output, 1/4 Brick



March 27, 2009

Bel Power, Inc., a subsidiary of Bel Fuse, Inc.

Absolute Maximum Ratings

Parameter	Min	Typ	Max	Unit	Notes
Continuous Input Voltage	-0.3	-	80	V	
Input Transient Voltage	-	-	100	V	100 mS maximum
Remote On/Off	-0.3	-	18	V	
I/O Isolation Voltage	-	-	1500	V	
Ambient Temperature	-40	-	85	°C	
Storage Temperature	-55	-	125	°C	

Note: Ratings used beyond the maximum ratings may cause a reliability degradation of the converter or may permanently damage the device.

Input Specifications

Parameter	Min	Typ	Max	Unit	Notes
Operating Input Voltage	36	48	75	V	
Input Current (full load)	-	-	10	A	
Input Current (no load)	-	100	-	mA	
Remote Off Input Current	-	10	-	mA	
Input Reflected Ripple Current (rms)	-	15	-	mA	Tested with simulated source impedance of 10 uH, 5 Hz to 20 MHz; use a 100 uF/100 V electrolytic capacitor with ESR = 1 ohm max. at 200 kHz at 25 °C.
Input Reflected Ripple Current (pk-pk)	-	50	-	mA	
I ² t Inrush Current Transient	-	TBD	-	A ² s	
Turn-on Voltage Threshold	-	34.5	35.5	V	
Turn-off Voltage Threshold	32.5	33.5	-	V	

CAUTION: This converter is not internally fused. An input line fuse must be used in application.

Recommend a fast-acting fuse with maximum rating of 13A on system board. Refer to the fuse manufacturer's datasheet for further information.

- Notes:**
1. This converter has internal C-L-C (1uF-1.0uH-15.4uF) filter.
 2. For recommended external input filter, please refer to **Safety** section (page 14).
 3. All specifications are typical at 25 °C unless otherwise stated.

Output Specifications

Parameter	Min	Typ	Max	Unit	Notes
Output Voltage Set Point	11.760	12.004	12.240	V	V _{in} =48V, I _o =50% load
Load Regulation	-	±30	±60	mV	
Line Regulation	-	±12	±24	mV	
Regulation Over Temperature (-40deg.C-85deg.C)	-	±60	±100	mV	
Ripple and Noise (pk-pk)	-	150	200	mV	0-20 MHz BW, with a 1µF ceramic capacitor and a 10uF Tantalum cap at output.
Ripple and Noise (rms)	-	40	80	mV	
Ripple and Noise (pk-pk) under worst case	-	-	TBD	mV	over all operating input voltage, load and temperature conditions.

ISOLATED DC/DC CONVERTERS

36 Vdc - 75 Vdc Input 12 Vdc /25 A Output, 1/4 Brick



March 27, 2009

Bel Power, Inc., a subsidiary of Bel Fuse, Inc.

Output Specifications (continued)

Parameter	Min	Typ	Max	Unit	Notes	
Output Current Range	0	-	25	A		
Output DC Current Limit	-	33	-	A		
Short Circuit Surge Transient	-	TBD	-	A ² s		
Turn on Time	-	100	150	mS		
Overshoot at Turn on	-	0	3	%		
Output Capacitance	0	-	5600	uF		
Transient Response						
△V50%~75% of Max Load	Overshoot	-	-	400	mV	di/dt=0.1A/us, Vin=48Vdc, Ta=25°C, with a 1µF ceramic capacitor and a 10uF Tantalum cap at the output.
	Settling Time	-	-	300	uS	
△V75%~50% of Max Load	Overshoot	-	-	400	mV	
	Settling Time	-	-	300	uS	

Note: All specifications are typical at nominal input, full load at 25°C unless otherwise stated.

General Specifications

Parameter	Min	Typ	Max	Unit	Notes
Efficiency	-	95.5	-	%	Vin=48V, full load
Switching Frequency	-	250	-	kHz	
Output Voltage Trim Range	90	-	105	%Vo	This voltage is achieved by trimming up output slowly
Over Temperature Protection	-	125	-	°C	
Over Voltage Protection(Static)	-	14	-	V	
Weight	-	60	-	g	
FIT	TBD			-	Calculated Per Bell Core SR-332 (Vin=48 V, Vo=12 V, Io=20 A, Ta = 25 °C, FIT=10 ⁹ /MTBF)
Dimensions	Inches (L x W x H) Millimeters (L x W x H)			-	2.30 x 1.45 x 0.50 58.42 x 36.83 x 12.70
Isolation characteristics					
Input to Output	-	-	1500	V	
Input to Case	-	-	1500	V	
Output to Case	-	-	500	V	
Isolation Resistance	10M	-		ohm	
Isolation Capacitance	-	2200	-	pF	

Note: All specifications are typical at 25 °C unless otherwise stated.

ISOLATED DC/DC CONVERTERS

36 Vdc - 75 Vdc Input 12 Vdc /25 A Output, 1/4 Brick



March 27, 2009

Bel Power, Inc. , a subsidiary of Bel Fuse, Inc.

Efficiency Data

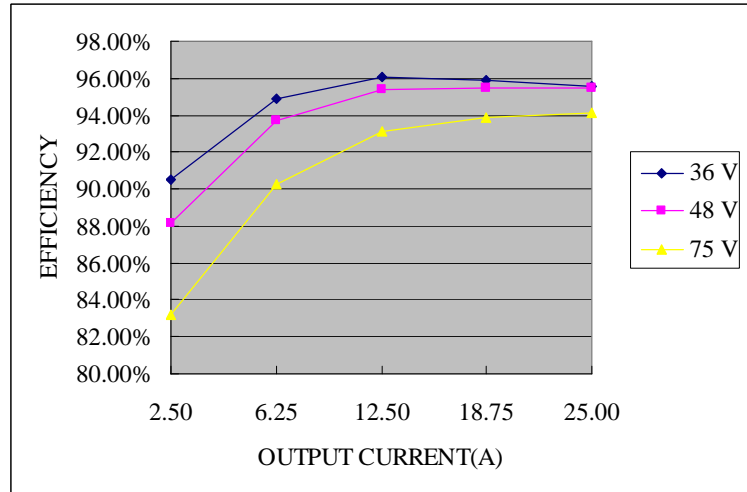

Thermal Derating Curves

Maximum junction temperature of semiconductors derated to 120 degree C.

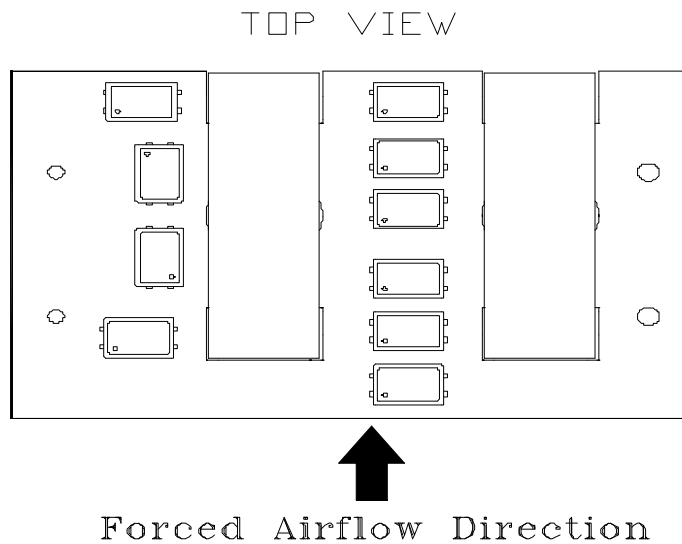

ISOLATED DC/DC CONVERTERS

36 Vdc - 75 Vdc Input 12 Vdc /25 A Output, 1/4 Brick



March 27, 2009

Bel Power, Inc., a subsidiary of Bel Fuse, Inc.

Thermal Derating Curves (continued)

Derating curve under normal input

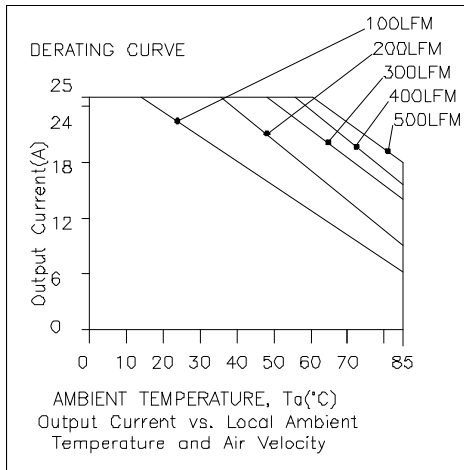

Derating curve under worse case input

TBD

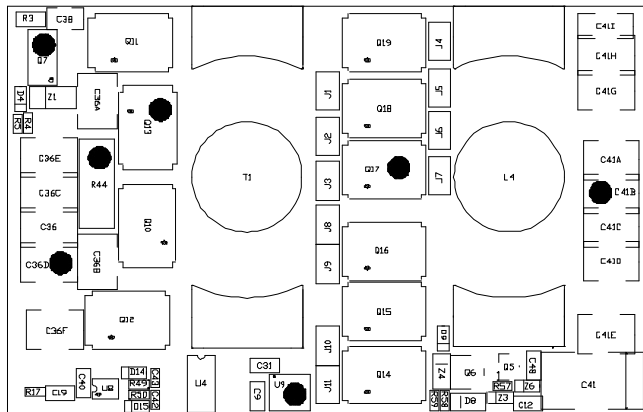

Temperature reference points on top side

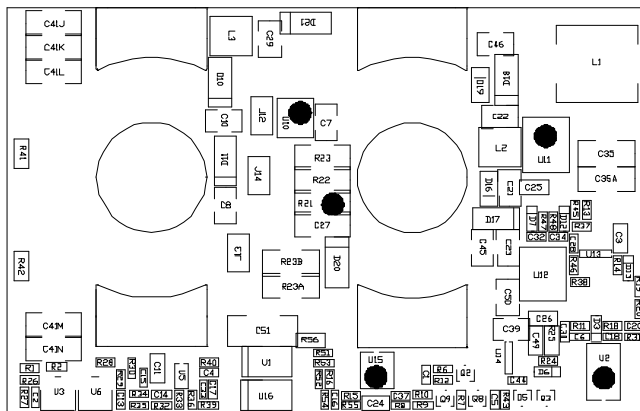

Temperature reference points on bottom side

ISOLATED DC/DC CONVERTERS

36 Vdc - 75 Vdc Input 12 Vdc /25 A Output, 1/4 Brick



March 27, 2009

Bel Power, Inc. , a subsidiary of Bel Fuse, Inc.

Ripple and Noise Waveform

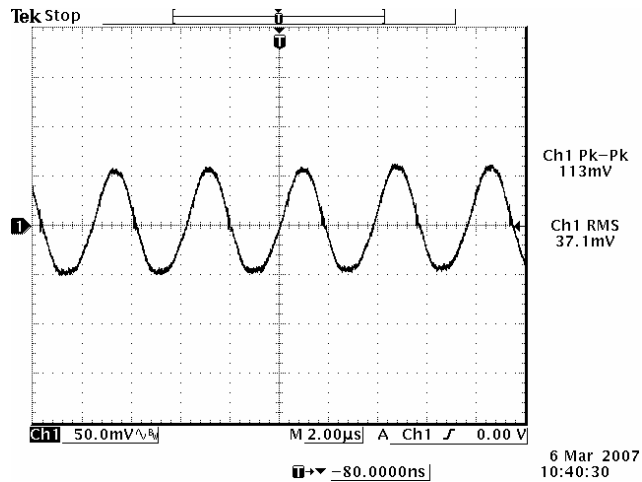

48 Vdc input, 12Vdc/25A output

Note: Ripple and Noise at full load, $T_a=25^\circ\text{C}$, with a $1\mu\text{F}$ ceramic capacitor and a $10\mu\text{F}$ Tantalum cap at the output.

Transient Response Waveforms

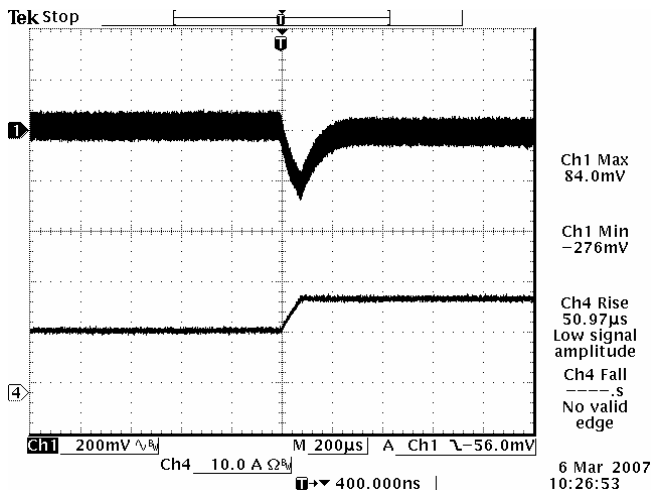

50%-75% Load Transients

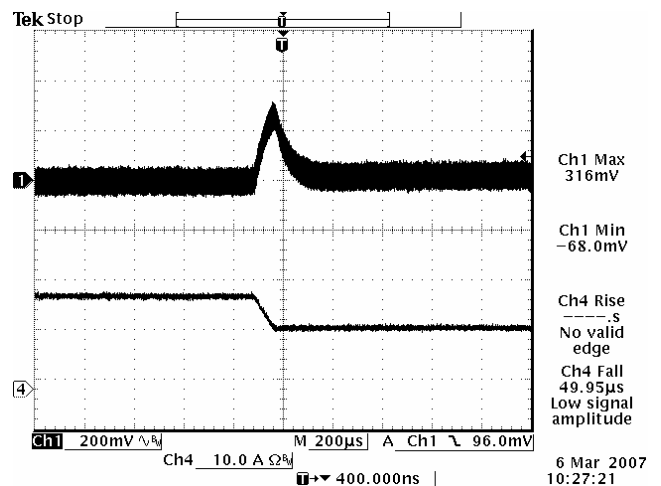

75%-50% Load Transients

Note: Transient Response at $di/dt=0.1\text{A}/\mu\text{s}$, $T_a=25^\circ\text{C}$, with $1\mu\text{F}$ ceramic cap and $10\mu\text{F}$ aluminum cap at output.

ISOLATED DC/DC CONVERTERS

36 Vdc - 75 Vdc Input 12 Vdc /25 A Output, 1/4 Brick



March 27, 2009

Bel Power, Inc., a subsidiary of Bel Fuse, Inc.

Startup & Shutdown

Rise Time

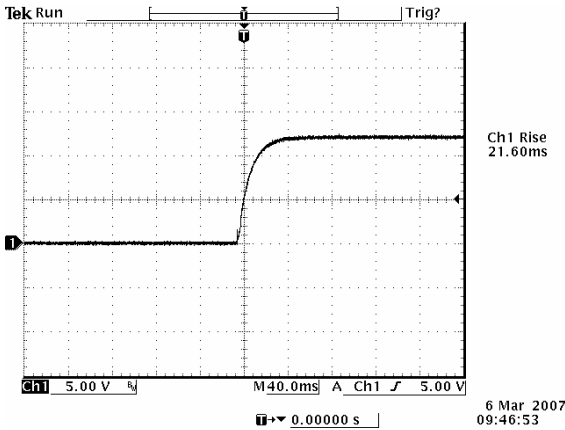

Test Condition:
48Vdc input, 12Vdc/25A
output, and Ta=25 deg C

Startup time

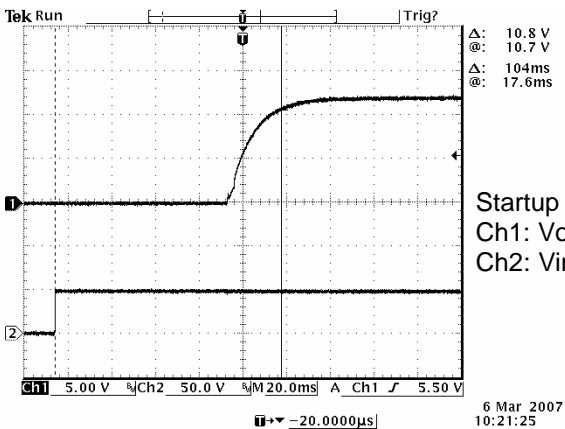

Test Condition: 48Vdc input, 12Vdc/25A output
and Ta=25 deg C

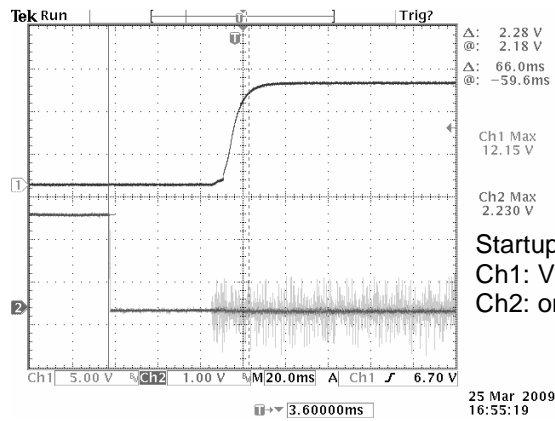

Test Condition: 48Vdc input, 12Vdc/25A output
and Ta=25 deg C

Shutdown

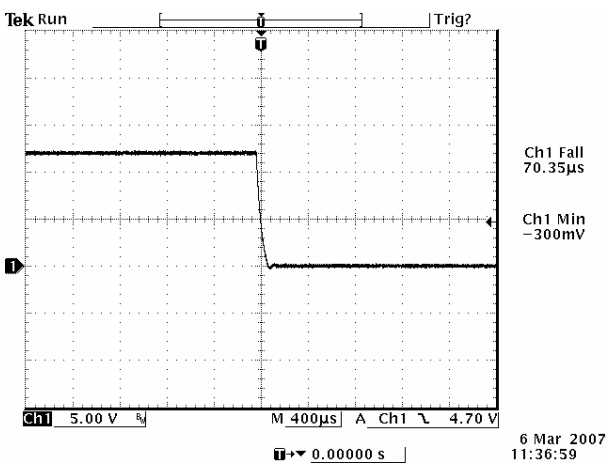

Test Condition:
48Vdc input, 12Vdc/25A
output, and Ta=25 deg C

ISOLATED DC/DC CONVERTERS

36 Vdc - 75 Vdc Input 12 Vdc /25 A Output, 1/4 Brick



March 27, 2009

Bel Power, Inc., a subsidiary of Bel Fuse, Inc.

Remote On/Off

Parameter		Min	Typ	Max	Unit	Notes
Signal Low (Unit On)	Active Low	-0.3	-	0.8	V	0RQB-T0T12L. The remote on/off pin open, Unit off.
Signal High (Unit Off)		2.4	-	18	V	
Signal Low (Unit Off)	Active High	-0.3	-	0.8	V	0RQB-T0T120. The remote on/off pin open, Unit on.
Signal High (Unit On)		2.4	-	18	V	
Current Sink		0	-	0.75	mA	

Recommended remote on/off circuit for active low

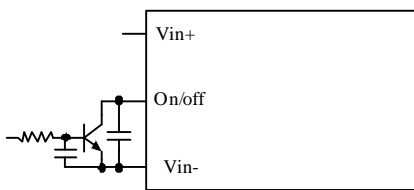

Control with open collector/drain circuit

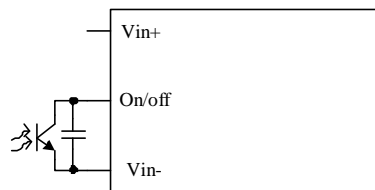

Control with photocoupler circuit

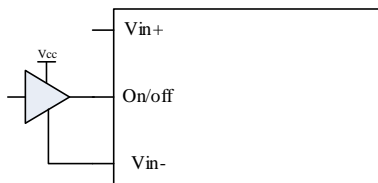

Control with logic circuit

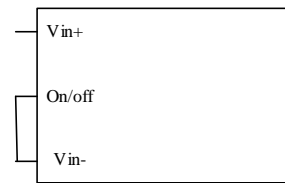

Permanently on

Recommended remote on/off circuit for active high

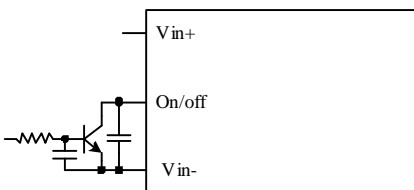

Control with open collector/drain circuit

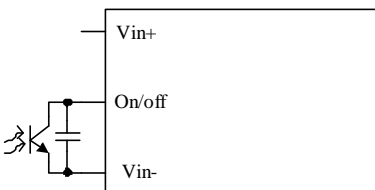

Control with photocoupler circuit

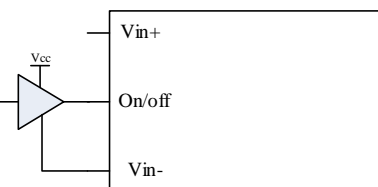

Control with logic circuit

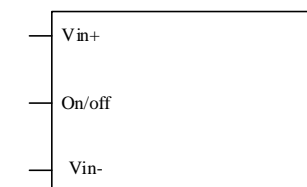

Permanently on

ISOLATED DC/DC CONVERTERS

36 Vdc - 75 Vdc Input 12 Vdc /25 A Output, 1/4 Brick



March 27, 2009

Bel Power, Inc. , a subsidiary of Bel Fuse, Inc.

Output Trim Equations

Equations for calculating the trim resistor are shown below. The Trim Down resistor should be connected between the Trim pin and GND pin. The Trim Up resistor should be connected between the Trim pin and the Vout pin. Only one of the resistors should be used for any given application.

Minimum trim down voltage is 10.8V

Maximum trim up voltage is 12.6V.

The total voltage increased by trim and remote sense should not exceed 5% of the nominal output voltage.

$$R_{trimdown} = \frac{V_{o_req}}{|V_o - V_{o_req}|} - 1 [k\Omega]$$

$$R_{trimup} = \frac{V_{o_req}}{|V_o - V_{o_req}|} - 1 [k\Omega]$$

Note:

$$\delta = \frac{(V_{o_req} - V_o)}{V_o} \times 100 [\%]$$

V_{o_req}=Desired (trimmed) output voltage [V]

Output voltage V_o=12.006 V

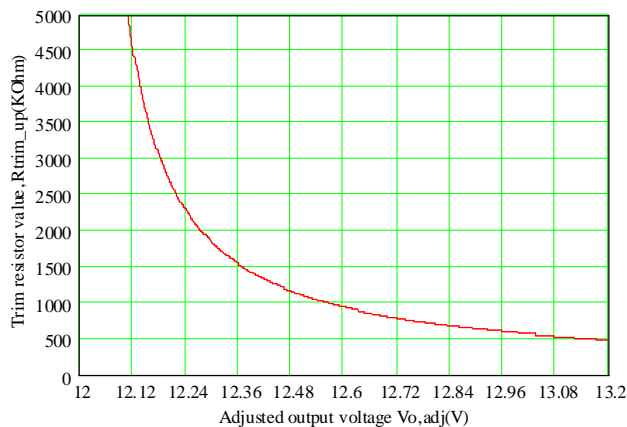
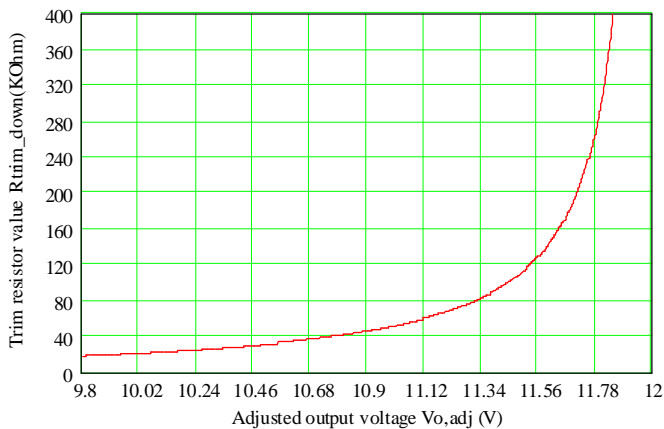
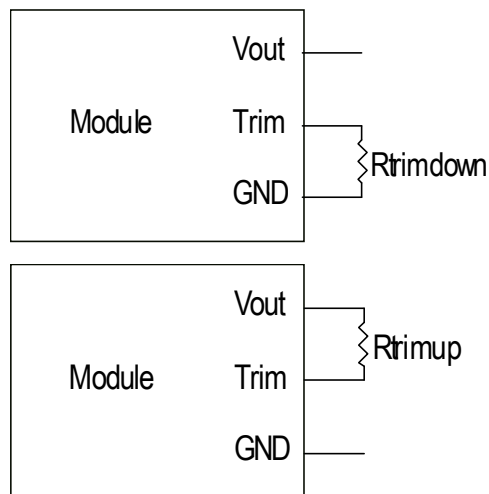

ISOLATED DC/DC CONVERTERS

36 Vdc - 75 Vdc Input 12 Vdc /25 A Output, 1/4 Brick

bel

March 27, 2009

Bel Power, Inc. , a subsidiary of Bel Fuse, Inc.

Remote Sense

This module has remote sense compensation feature. It can minimize the effects of resistance between module's output and load in system layout and facilitates accurate voltage regulation at load terminals or other selected point.

1. The remote sense lines carries very little current and hence do not require a large cross-sectional area.
2. This module compensates for a maximum drop of 5% of the nominal output voltage.
3. If the unit is already trimmed up, the available remote sense compensation range should be correspondingly reduced. The total voltage increased by trim and remote sense should not exceed 5% of the nominal output voltage.
4. When using remote sense compensation, all the resistance, parasitic inductance and capacitance of the system are incorporated within the feedback loop of this module. It can make an effect on the module's compensation, affecting the stability and dynamic response. A 0.1uF ceramic capacitor can be connected at the point of load to de-couple noise on the sense wires.
5. Recommend the connection of remote sense compensation as below figure. There are a resistor RS+ (30.1 ohm) from Vo+ to Sense+ and a resistor RS- (30.1 ohm) from Vo- to Sense- inside of this module.

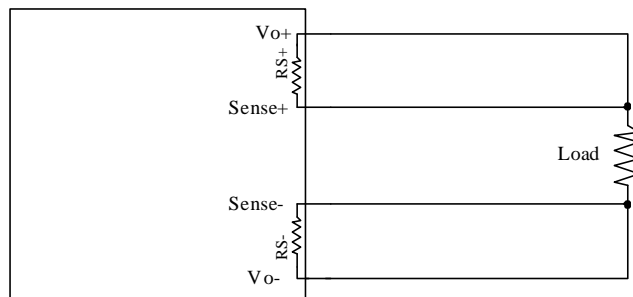

6. If not using remote sense compensation, please connect sense directly to output at module's pin, that is, connect sense+ to Vo+ and sense- to Vo- at module's pin, the shorter the better. See below figure.

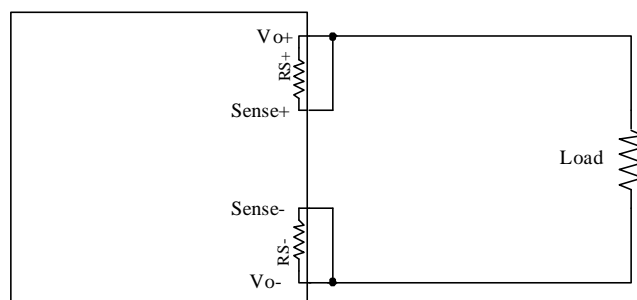

ISOLATED DC/DC CONVERTERS

36 Vdc - 75 Vdc Input 12 Vdc /25 A Output, 1/4 Brick



March 27, 2009

Bel Power, Inc., a subsidiary of Bel Fuse, Inc.

Over Current Protection

To provide protection in a fault output overload condition, the module is equipped with internal current-limiting circuitry and can endure current limiting for a few milli-seconds. If the overcurrent condition persists beyond a few milliseconds, the module will shut down into hiccup mode and restart once every 344mS. The module operates normally when the output current goes into specified range. The typical average output current is 0.3A during hiccup.

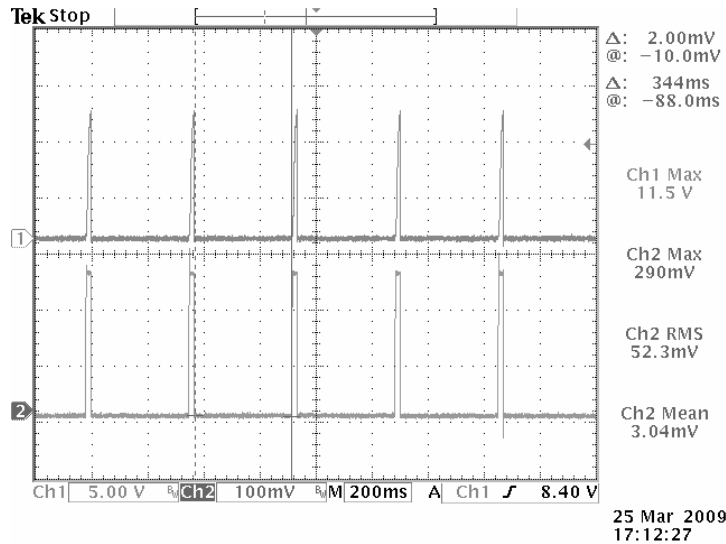

CH1: Output voltage waveform
CH2: output current waveform and 1A/10mV
Test at: 48Vdc input, over current output and Ta=25 deg C

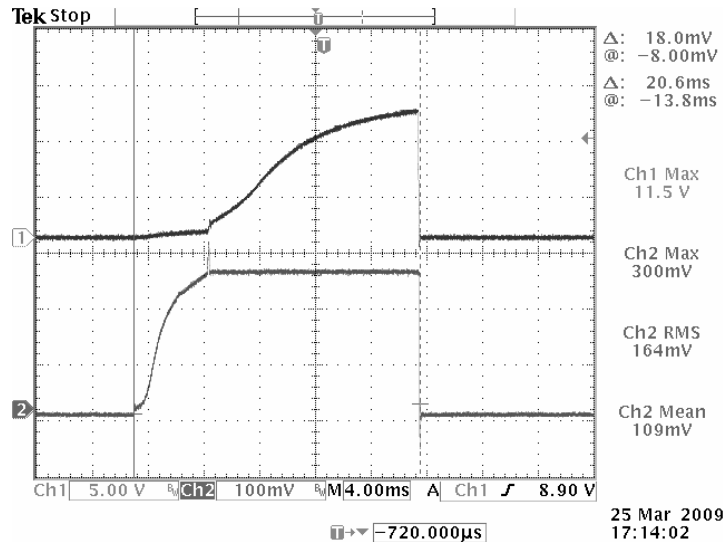

Expansion of on time portion of above figure

ISOLATED DC/DC CONVERTERS

36 Vdc - 75 Vdc Input 12 Vdc /25 A Output, 1/4 Brick



March 27, 2009

Bel Power, Inc. , a subsidiary of Bel Fuse, Inc.

Over Voltage Protection

The output overvoltage protection consists of circuitry that monitors the voltage on the output terminals. If the voltage on the output terminals exceeds the over voltage protection threshold, the module will shutdown into latch off mode. The overvoltage latch can be reset by either cycling the input power or toggling the on/off signal for one second at least.

Note: Due to maximum duty cycle limit, output voltage can not be trimmed up to OVP set point in low line input.

Test setup:

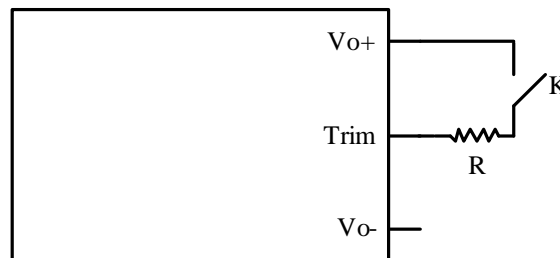

R=10k ohm

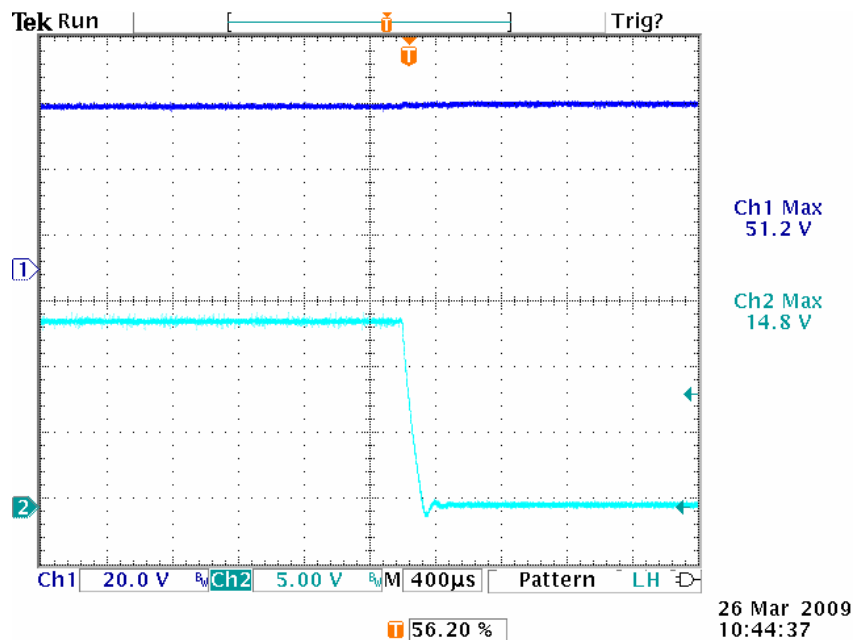

CH1: Input voltage waveform
CH2: Output voltage waveform

ISOLATED DC/DC CONVERTERS

36 Vdc - 75 Vdc Input 12 Vdc /25 A Output, 1/4 Brick



March 27, 2009

Bel Power, Inc., a subsidiary of Bel Fuse, Inc.

Over Temperature Protection

The OTP is achieved by thermistor R25 and the threshold is set at 120C in non-latch mode; the hottest component Q13 reaches 125C with 100LFM air flow correspondingly. It will restart automatically when the temperature falls down to 110C. The protecting point will be varied a little under different conditions (air flow, ambient temperature, input voltage, load...).

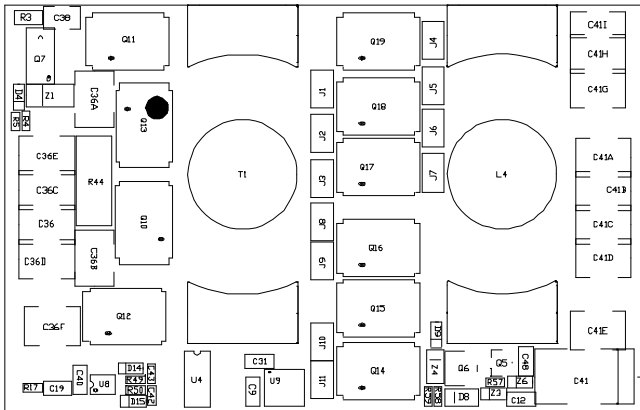

The hottest component on the top side: Q13

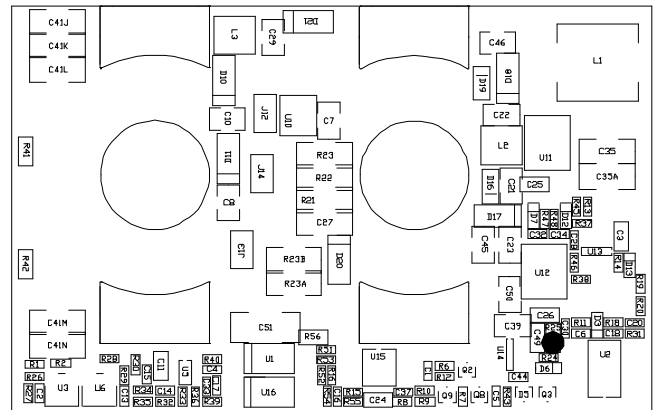

The thermistor on the bottom side: R25

Input Under-voltage Lockout

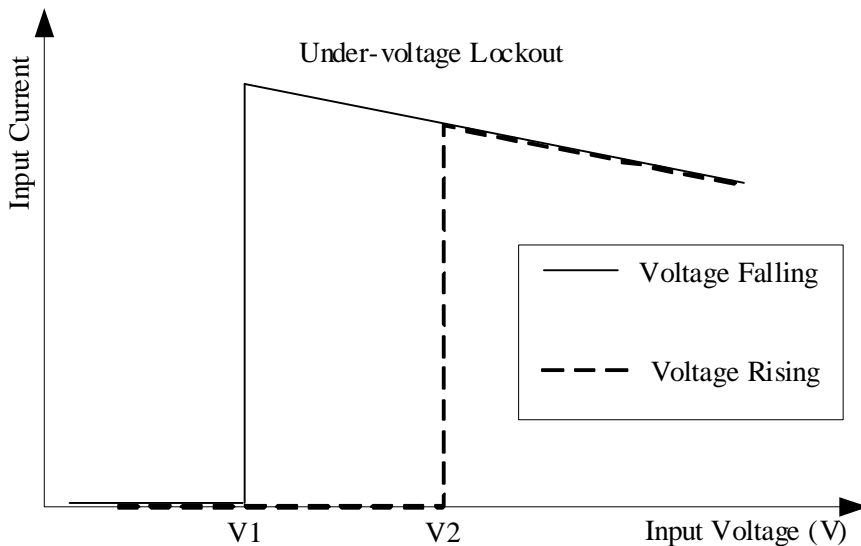

V1=33.5V
V2=34.5V

ISOLATED DC/DC CONVERTERS

36 Vdc - 75 Vdc Input 12 Vdc /25 A Output, 1/4 Brick

March 27, 2009

Bel Power, Inc. , a subsidiary of Bel Fuse, Inc.

Safety & EMC

Safety

1. Material flammability UL94V-0
2. TUV Certification EN60950-1
3. UL Certification UL60950-1

EMC

1. Surge IEC61000-4-5
2. DC-DIP IEC61000-4-29
3. Conductive EMI EN55022 class B

Compliance to EN55022 class B (both q.peak and average) with the following inductive and capacitive filter

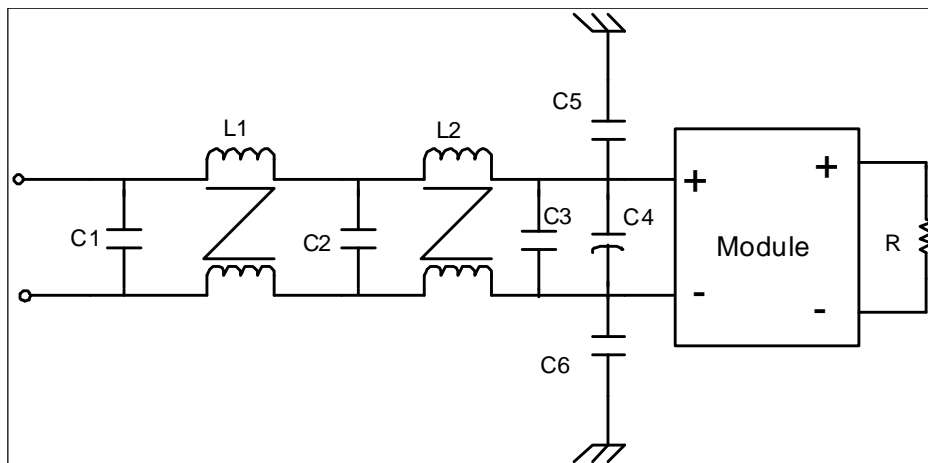

Item	Designator	Parameter	Vendor	Vendor P/N
1	C1	2.2uF/100V,ceramic	Murata	GRF32ER72A225KA11L
2	C2	2.2uF/100V,ceramic	Murata	GRF32ER72A225KA11L
3	C3	2.2uF/100V,ceramic	Murata	GRF32ER72A225KA11L
4	C4	270uF/100V,AL Cap	Nichicon	UHE2A271MHD
5	C5	2200pF/2000V,ceramic	Johanson	202R29W222KV4E
6	C6	2200pF/2000V,ceramic	Johanson	202R29W222KV4E
7	L1	0.809mH, common mode	VAC	T60004-L2025-W622
8	L2	0.809mH, common mode	VAC	T60004-L2025-W622

ISOLATED DC/DC CONVERTERS

36 Vdc - 75 Vdc Input 12 Vdc /25 A Output, 1/4 Brick



March 27, 2009

Bel Power, Inc., a subsidiary of Bel Fuse, Inc.

Safety & EMC (continued)

Positive

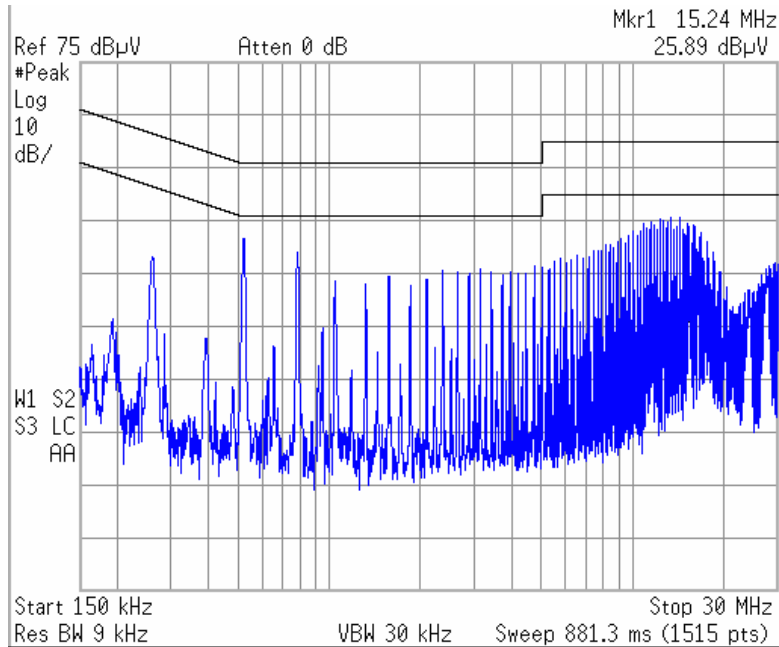

Negative

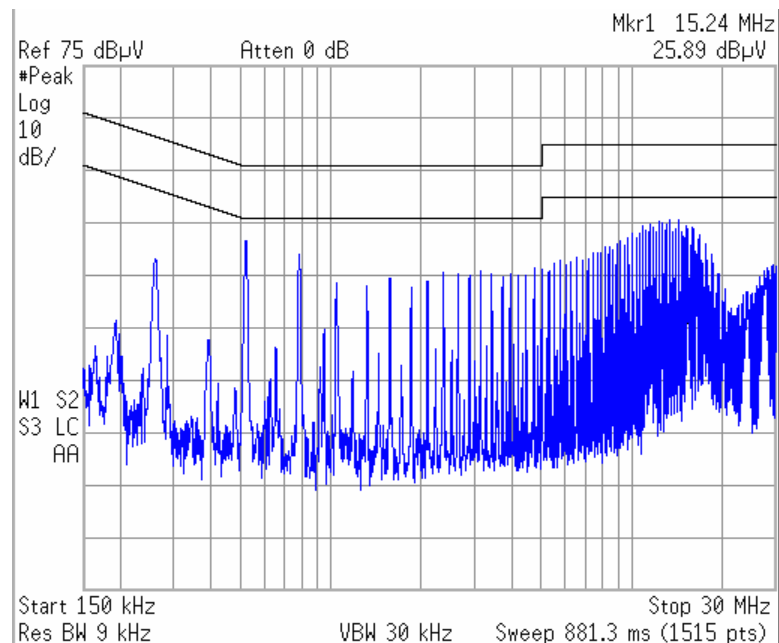

ISOLATED DC/DC CONVERTERS

36 Vdc - 75 Vdc Input 12 Vdc /25 A Output, 1/4 Brick



March 27, 2009

Bel Power, Inc., a subsidiary of Bel Fuse, Inc.

Layout

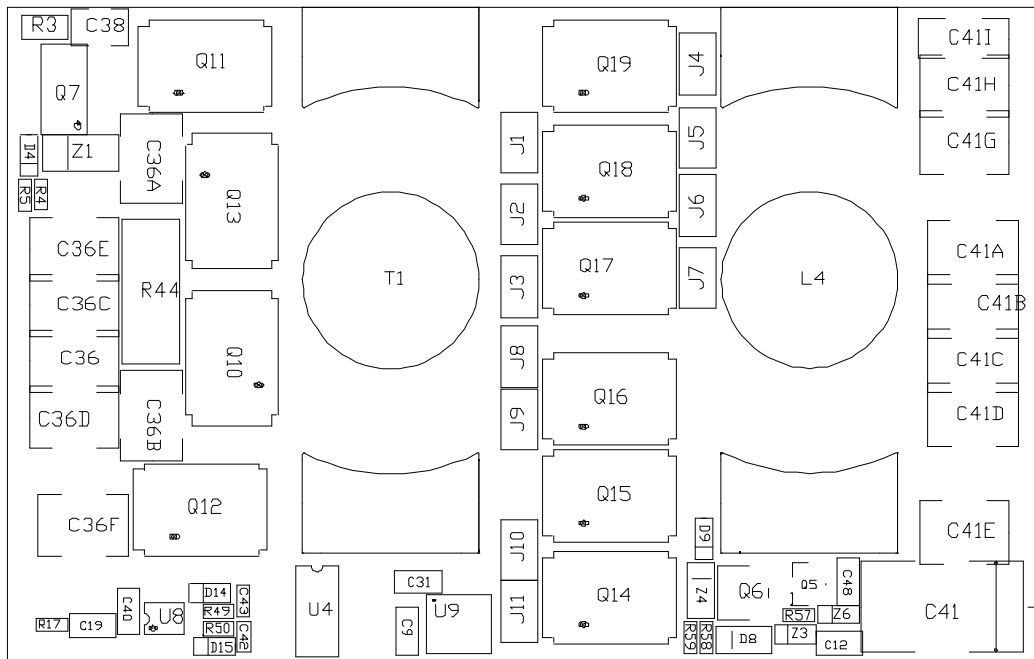

Layout of components on top side

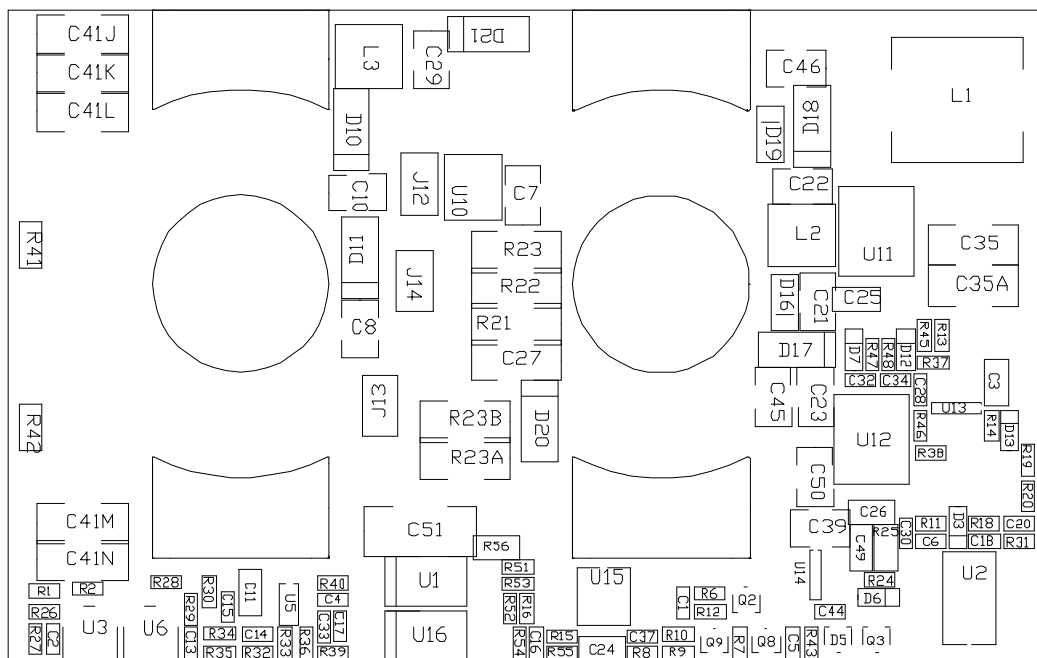

Layout of components on bottom side

ISOLATED DC/DC CONVERTERS

36 Vdc - 75 Vdc Input 12 Vdc /25 A Output, 1/4 Brick



March 27, 2009

Bel Power, Inc., a subsidiary of Bel Fuse, Inc.

Mechanical Outline

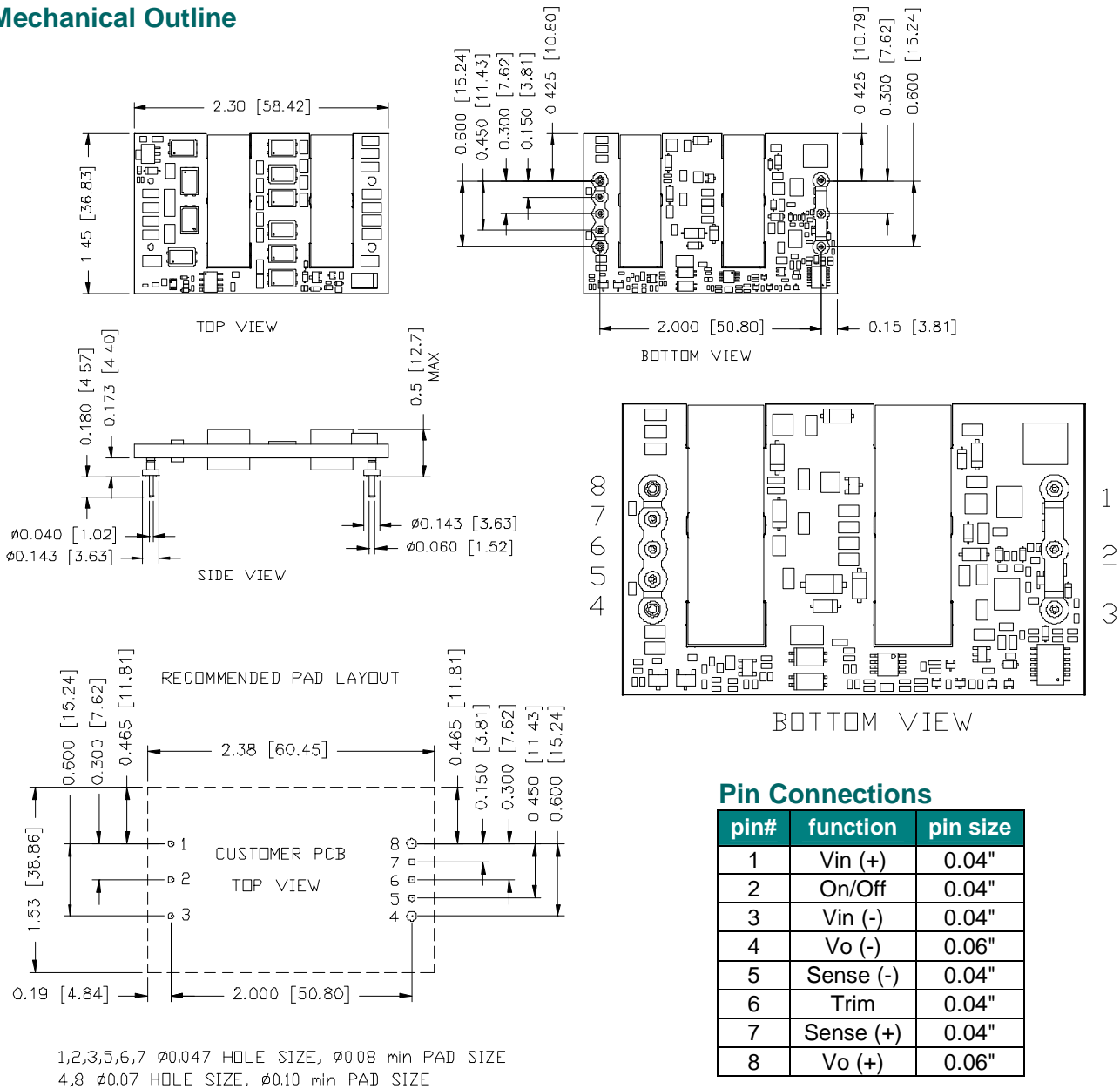

Note: This module is recommended and compatible with Pb-Free Wave Soldering and must be soldered using a peak solder temperature of no more than 260 °C for less than 5 seconds.

Note:

- 1) All Pins: Material - Copper Alloy;
Finish – 3 micro inches minimum Gold over 50 micro inches minimum Nickel plate.
- 2) Undimensioned components are shown for visual reference only.
- 3) All dimensions in inches (mm); Tolerances: x.xx +/-0.02 in. (x.x +/-0.5mm) x.xxx +/-0.010 in. (x.xx +/-0.25mm).

ISOLATED DC/DC CONVERTERS
 36 Vdc - 75 Vdc Input 12 Vdc /25 A Output, 1/4 Brick



March 27, 2009

Bel Power, Inc. , a subsidiary of Bel Fuse, Inc.

Labeling Information

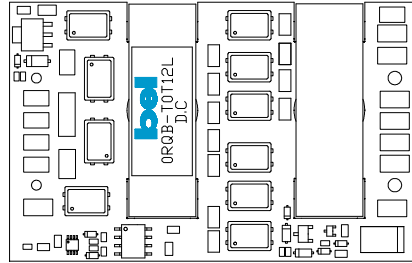

Top View

TECHNICAL REVISIONS - The appearance of products, including safety agency certifications and D.C. (Date Code) pictured on labels, may change depending on the date manufactured.

Packing Instruction

TBD

Revision History

Date	Version	Changes Detail	Approval
2007-5-28	A	First release	
2007-7-18	B	Update efficiency data curve and TD curve	
2009-3-27	C	1. Change to new format, include adding application, part number explaining, remote sense, OCP, OVP, OTP, UVLO, startup&shutdown, safety&EMC and so on. 2. Add input transient voltage, input C-L-C filter, recommended input fast-acting fuse on system board. 3. Update trim equations.	

RoHS Compliance

Complies with the European Directive 2002/95/EC, calling for the elimination of lead and other hazardous substances from electronic products.



©2009 Bel Fuse Inc. Specifications subject to change without notice. 032709

CORPORATE

Bel Fuse Inc.
 206 Van Vorst Street
 Jersey City, NJ 07302
 Tel 201-432-0463
 Fax 201-432-9542
www.belfuse.com

FAR EAST

Bel Fuse Ltd.
 8F/ 8 Luk Hop Street
 San Po Kong
 Kowloon, Hong Kong
 Tel 852-2328-5515
 Fax 852-2352-3706
www.belfuse.com

EUROPE

Bel Fuse Europe Ltd.
 Preston Technology Management Centre
 Marsh Lane, Suite G7, Preston
 Lancashire, PR1 8UD, U.K.
 Tel 44-1772-556601
 Fax 44-1772-888366
www.belfuse.com