

# CFE370 Series

## Fiber Optic AlGaAs IREDS

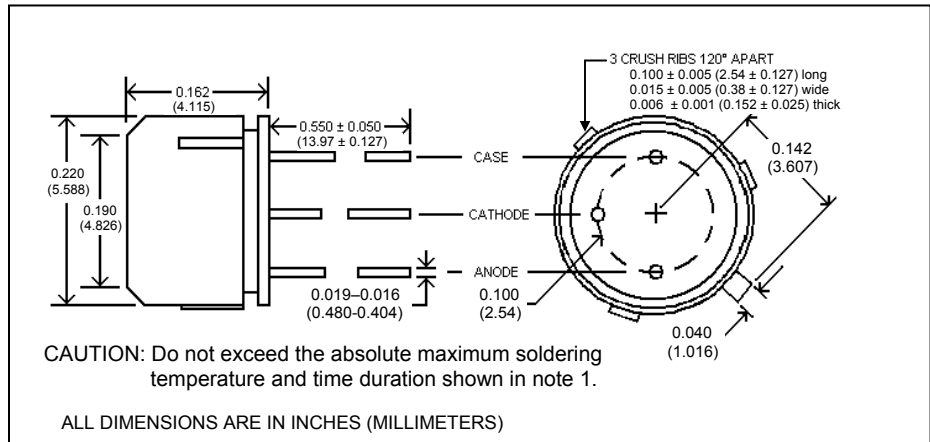

April, 2004

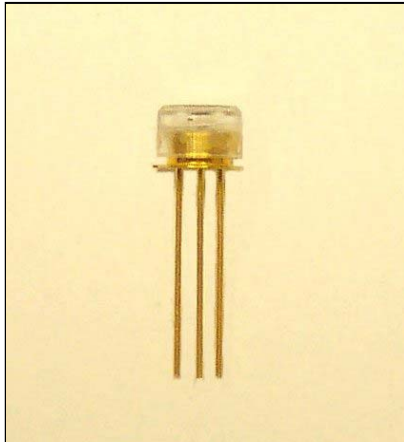

### features

- High power output
- High speed
- Optimized for fiber-optic applications
- TO-18 header with plastic lens
- RoHS compliant

### description

The CFE370 series contain 850nm AlGaAs IREDS mounted on TO-18 headers. The devices are designed to self-align in the 0.228" (5.79mm) bore of a standard fiber-optic receptacle. Three crush ribs on the outside of the case provide press-fit installation and precise alignment.

### absolute maximum ratings (T<sub>A</sub> = 25°C unless otherwise stated)

storage temperature .....	-55°C to +115°C
operating temperature.....	-40°C to +100°C
lead soldering temperature <sup>(1)</sup> .....	260°C
reverse voltage .....	1.0VDC
continuous forward current <sup>(2)</sup> .....	100mA

### notes:

1. 1/16" (1.6mm) from case for 5 seconds maximum.
2. Derate linearly 1.07mA/°C from 25°C free air temperature to T<sub>A</sub> = +100°C.

electrical characteristics (T <sub>A</sub> = 25°C, V <sub>CC</sub> = 5VDC unless otherwise noted)							
symbol	parameter		min	typ	max	units	test conditions
P <sub>O</sub>	Total power output	CFE370A	25	29	-	μW	I <sub>F</sub> = 100mA <sup>(3)</sup>
		CFE370B	15	20	-		
		CFE370C	5	10	-		
V <sub>F</sub>	Forward voltage		-	1.7	2.2	V	I <sub>F</sub> = 100mA
λ <sub>P</sub>	Peak emission wavelength		-	850	-	nm	I <sub>F</sub> = 100mA
BW	Spectral bandwidth at half power points		-	35	-	nm	I <sub>F</sub> = 100mA
t <sub>r</sub>	Output rise time		-	5.0	8.0	ns	I <sub>F</sub> = 100mA, 10% - 90% <sup>(4)</sup>
t <sub>f</sub>	Output fall time		-	5.0	10	ns	I <sub>F</sub> = 100mA, 90% - 10% <sup>(4)</sup>

- notes: 3. Graded index fiber, 50 μm core, N.A. = 0.20.  
 4. Prebias at 5mA.

Clairex reserves the right to make changes at any time to improve design and to provide the best possible product.

Revised 7/6/06