

SGFM101C-D2 THRU SGFM108C-D2

List

List.....	1
Package outline.....	2
Features.....	2
Mechanical data.....	2
Maximum ratings	2
Rating and characteristic curves.....	3
Pinning information.....	4
Marking.....	4
Suggested solder pad layout.....	4
Packing information.....	5
Reel packing.....	6
Suggested thermal profiles for soldering processes.....	6
High reliability test capabilities.....	7

SGFM101C-D2 THRU SGFM108C-D2

10.0A Surface Mount Super Fast Rectifiers-50-600V

Features

- Batch process design, excellent power dissipation offers better reverse leakage current and thermal resistance.
- Low profile surface mounted application in order to optimize board space..
- High current capability.
- Super fast reovery time for switching mode application.
- High surge current capability.
- Glass passivated chip junction.
- Lead-free parts meet environmental standards of MIL-STD-19500/228
- Suffix "-H" indicates Halogen free parts, ex. SGFM101C-D2-H.

Mechanical data

- Epoxy:UL94-V0 rated flame retardant
- Case : Molded plastic, TO-263 / D2PAK
- Terminals : Solder plated, solderable per MIL-STD-750, Method 2026
- Polarity : Indicated by cathode band
- Mounting Position : Any
- Weight : Approximated 1.46 gram

Package outline

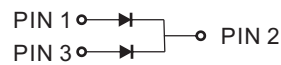
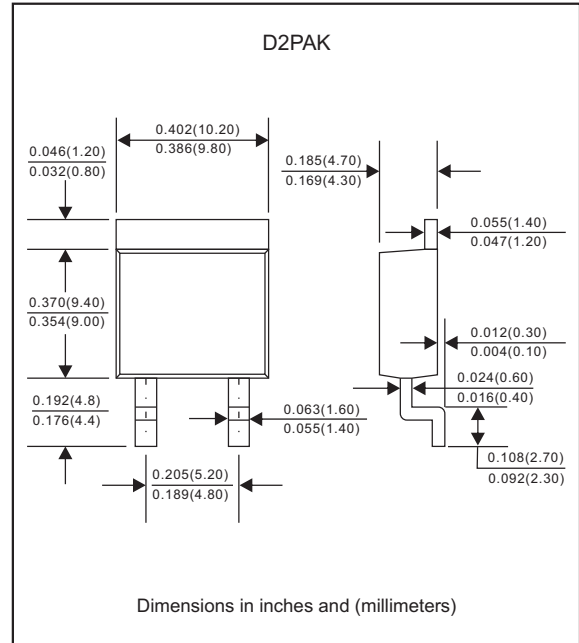

Maximum ratings and Electrical Characteristics (AT T_A=25°C unless otherwise noted)

PARAMETER	CONDITIONS	Symbol	MIN.	TYP.	MAX.	UNIT
Forward rectified current	Ambient temperature = 50°C	I _O			10.0	A
Forward surge current	8.3ms single half sine-wave superimposed on rate load (JEDEC methode)	I _{FSM}			150	A
Reverse current	V _R = V _{RRM} T _J = 25°C	I _R			10	μA
	V _R = V _{RRM} T _J = 125°C				50	
Diode junction capacitance	f=1MHz and applied 4V DC reverse voltage	C _J		80		pF
Storage temperature		T _{STG}	-65		+175	°C

SYMBOLS	V _{RRM} ^{*1} (V)	V _{RMS} ^{*2} (V)	V _R ^{*3} (V)	V _F ^{*4} (V)	t _{rr} ^{*5} (ns)	Operating temperature T _J (°C)
SGFM101C-D2	50	35	50	0.975	35	-55 to +150
SGFM102C-D2	100	70	100			
SGFM104C-D2	200	140	200			
SGFM106C-D2	400	280	400			
SGFM108C-D2	600	420	600			

- *1 Repetitive peak reverse voltage
- *2 RMS voltage
- *3 Continuous reverse voltage
- *4 Maximum forward voltage@I_F=5.0A
- *5 Reverse recovery time, note 1

Note 1. Reverse recovery time test condition, I_F=0.5A, I_R=1.0A, I_{RR}=0.25A

Rating and characteristic curves (SGFM101C-D2 THRU SGFM108C-D2)

FIG. 1 - FORWARD CURRENT DERATING CURVE

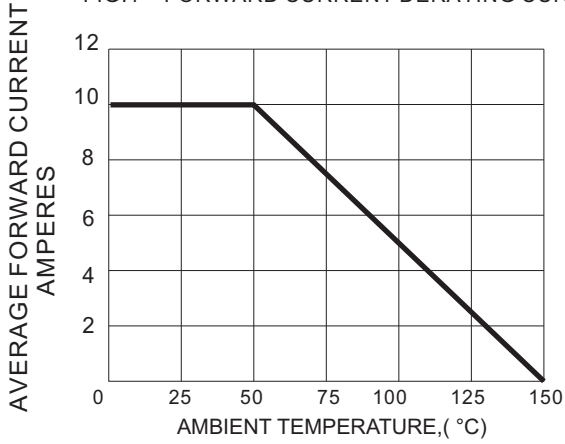

FIG. 2 - MAXIMUM NON-REPETITIVE PEAK FORWARD SURGE CURRENT

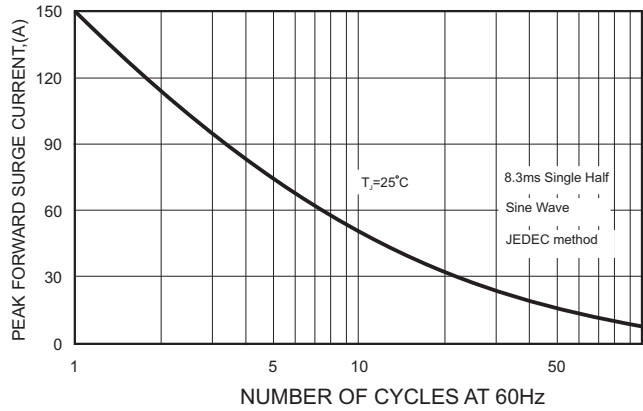

FIG. 3 - TYPICAL INSTANTANEOUS FORWARD CHARACTERISTICS

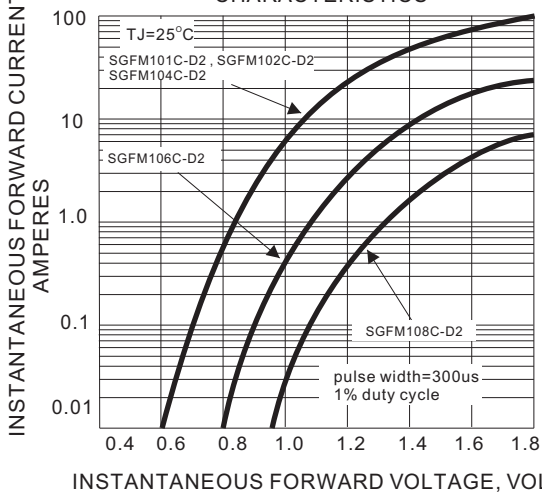

FIG. 4 - TYPICAL INSTANTANEOUS REVERSE CHARACTERISTICS

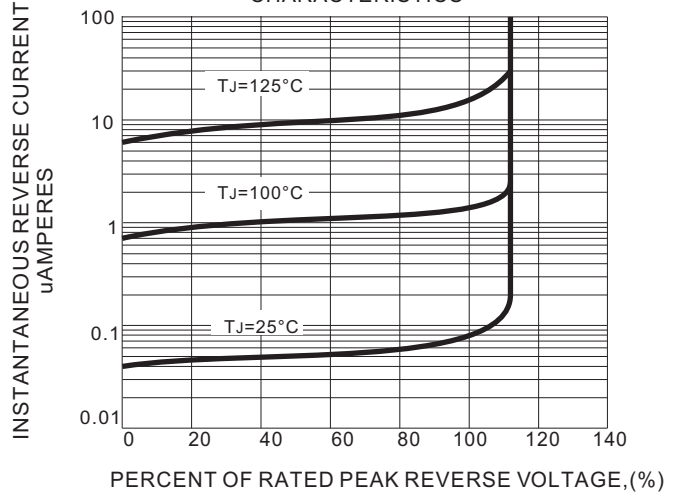

FIG. 5 - TYPICAL JUNCTION CAPACITANCE

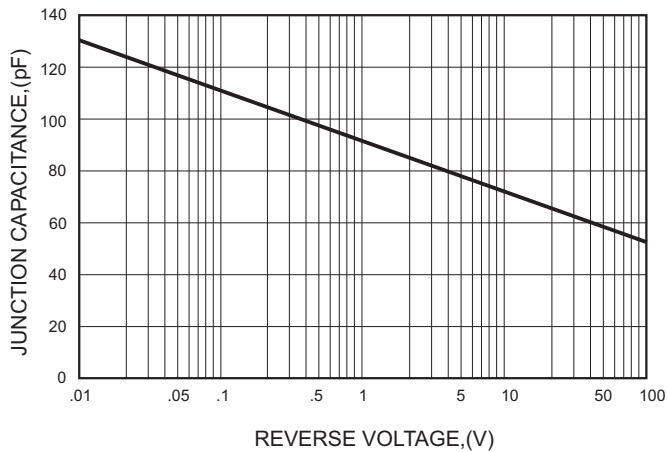
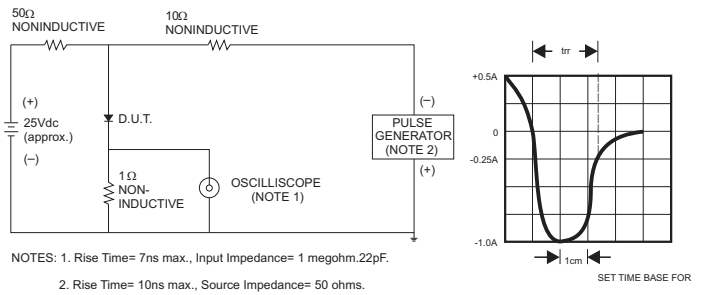
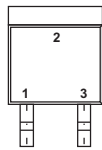
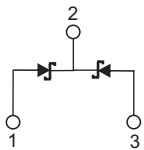

FIG. 6 - TEST CIRCUIT DIAGRAM AND REVERSE RECOVERY TIME CHARACTERISTIC



SGFM101C-D2 THRU SGFM108C-D2

Pinning information

Simplified outline	Symbol
	

Marking

Type number	Marking code
SGFM101C-D2	SF101C
SGFM102C-D2	SF102C
SGFM104C-D2	SF104C
SGFM106C-D2	SF106C
SGFM108C-D2	SF108C

Suggested solder pad layout

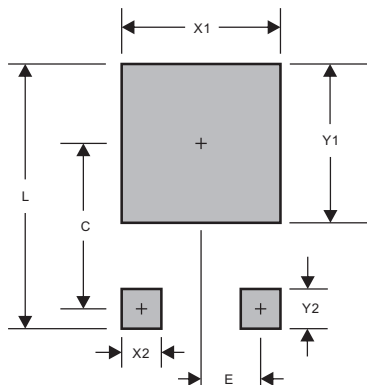

PACKAGE	D2PAK
C	0.374(9.50)
E	0.098(2.50)
L	0.665(16.90)
X1	0.425(10.80)
X2	0.071(1.80)
Y1	0.449(11.40)
Y2	0.138(3.50)

Dimensions in inches and (millimeters)

SGFM101C-D2 THRU SGFM108C-D2

Packing information

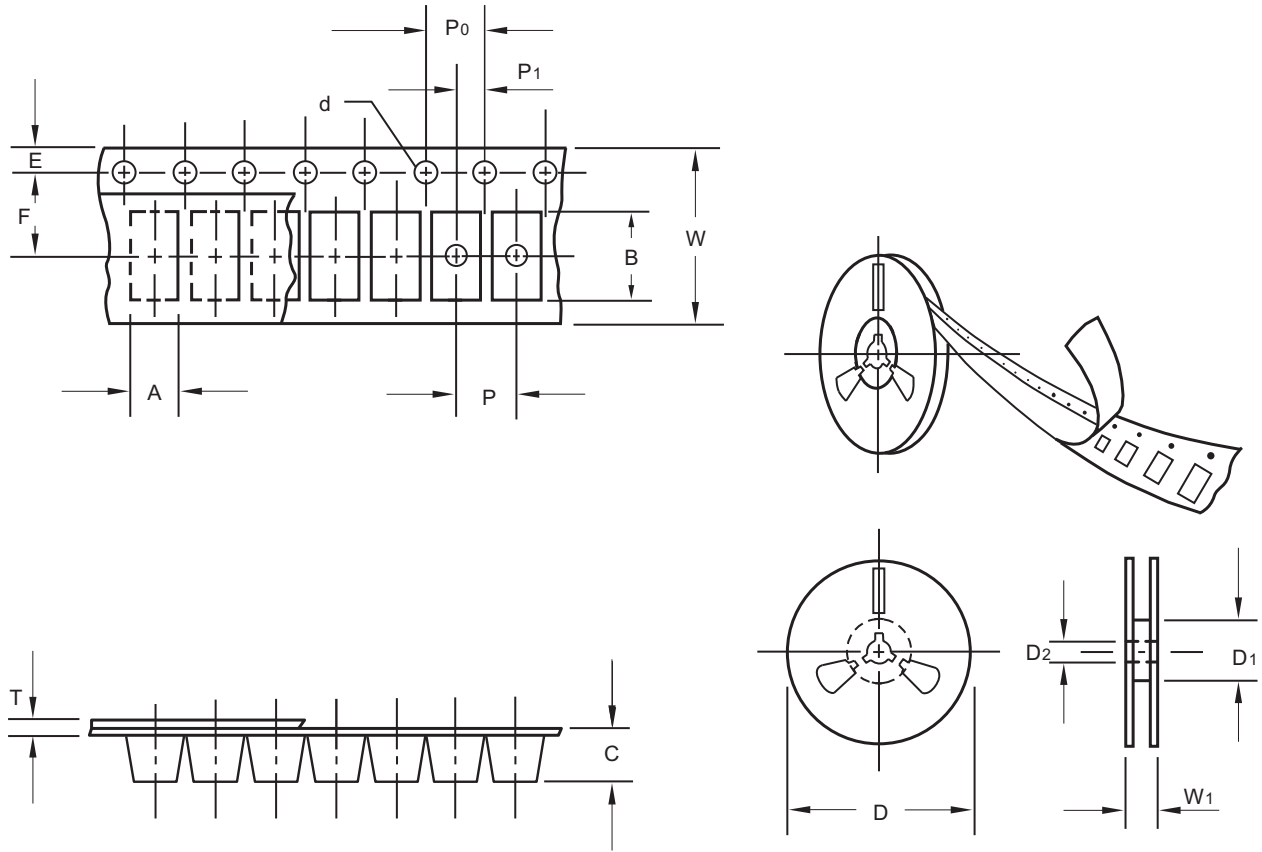

unit:mm

Item	Symbol	Tolerance	D2PAK
Carrier width	A	0.1	10.70
Carrier length	B	0.1	16.30
Carrier depth	C	0.1	5.10
Sprocket hole	d	0.1	1.50
13" Reel outside diameter	D	2.0	330.00
13" Reel inner diameter	D1	min	50.00
7" Reel outside diameter	D	2.0	-
7" Reel inner diameter	D1	min	-
Feed hole diameter	D2	0.5	13.00
Sprocket hole position	E	0.1	1.75
Punch hole position	F	0.1	11.50
Punch hole pitch	P	0.1	16.00
Sprocket hole pitch	P0	0.1	4.00
Embossment center	P1	0.1	2.00
Overall tape thickness	T	0.1	0.23
Tape width	W	0.3	24.00
Reel width	W1	1.0	30.00

Note: Devices are packed in accordance with EIA standard RS-481-A and specifications listed above.

SGFM101C-D2 THRU SGFM108C-D2

Reel packing

PACKAGE	REEL SIZE	REEL (pcs)	COMPONENT SPACING (m/m)	BOX (pcs)	INNER BOX (m/m)	REEL DIA, (m/m)	CARTON SIZE (m/m)	CARTON (pcs)	APPROX. GROSS WEIGHT (kg)
D2PAK/TO-263	13"	800	16.0	800	337*337*37	330	350*330*360	6,400	15.0

Suggested thermal profiles for soldering processes

- 1.Storage environment: Temperature=5°C~40°C Humidity=55%±25%
- 2.Reflow soldering of surface-mount devices

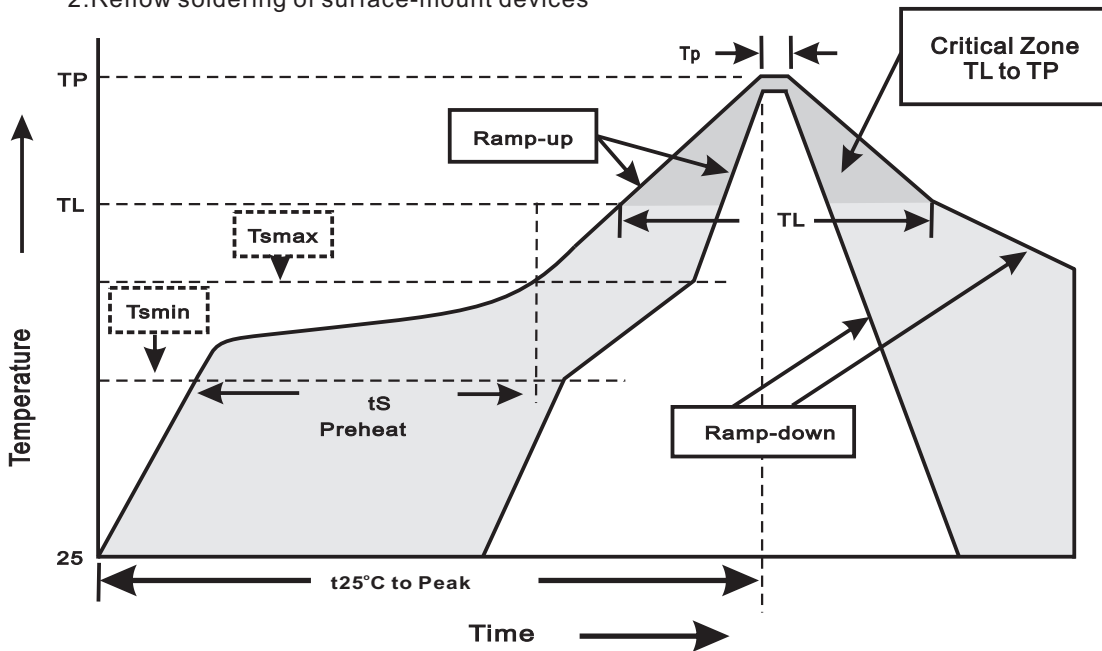

3.Reflow soldering

Profile Feature	Soldering Condition
Average ramp-up rate(T _L to T _P)	<3°C/sec
Preheat -Temperature Min(T _{sm}) -Temperature Max(T _{sm}) -Time(min to max)(t _s)	150°C 200°C 60~120sec
T _{sm} to T _L -Ramp-upRate	<3°C/sec
Time maintained above: -Temperature(T _L) -Time(t _L)	217°C 60~260sec
Peak Temperature(T _P)	255°C-0/+5°C
Time within 5°C of actual Peak Temperature(t _p)	10~30sec
Ramp-down Rate	<6°C/sec
Time 25°C to Peak Temperature	<6minutes

SGFM101C-D2 THRU SGFM108C-D2

High reliability test capabilities

Item Test	Conditions	Reference
1. Solder Resistance	at $260\pm 5^{\circ}\text{C}$ for $10\pm 2\text{sec}$. immerse body into solder $1/16''\pm 1/32''$	MIL-STD-750D METHOD-2031
2. Solderability	at $245\pm 5^{\circ}\text{C}$ for 5 sec.	MIL-STD-202F METHOD-208
3. High Temperature Reverse Bias	$V_R=80\%$ rate at $T_J=150^{\circ}\text{C}$ for 168 hrs.	MIL-STD-750D METHOD-1038
4. Forward Operation Life	Rated average rectifier current at $T_A=25^{\circ}\text{C}$ for 500hrs.	MIL-STD-750D METHOD-1027
5. Intermittent Operation Life	$T_A = 25^{\circ}\text{C}$, $I_F = I_O$ On state: power on for 5 min. off state: power off for 5 min. on and off for 500 cycles.	MIL-STD-750D METHOD-1036
6. Pressure Cooker	$15P_{SIG}$ at $T_A=121^{\circ}\text{C}$ for 4 hrs.	JESD22-A102
7. Temperature Cycling	-55°C to $+125^{\circ}\text{C}$ dwelled for 30 min. and transferred for 5min. total 10 cycles.	MIL-STD-750D METHOD-1051
8. Thermal Shock	0°C for 5 min. rise to 100°C for 5 min. total 10 cycles.	MIL-STD-750D METHOD-1056
9. Forward Surge	8.3ms single half sine-wave superimposed on rated load, one surge.	MIL-STD-750D METHOD-4066-2
10. Humidity	at $T_A=85^{\circ}\text{C}$, RH=85% for 1000hrs.	MIL-STD-750D METHOD-1021
11. High Temperature Storage Life	at 175°C for 1000 hrs.	MIL-STD-750D METHOD-1031