

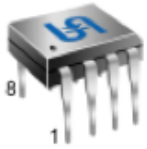

DIP-8



Pin Definition:

- | | |
|-----------|-----------|
| 1. Ring | 5. TIP |
| 2. Ground | 7. RC |
| 3. SRC | 6. AVA |
| 4. OFC | 5. Output |

General Description

The TS2418 is a monolithic integrated circuit telephone tone ringer with bridge diode, when coupled with an appropriate transducer, it replaces the electromechanical bell. This device is designed for use with either a piezo transducer or an inexpensive transformer coupled speaker to produce a pleasing tone composed of a high frequency (fR) alternating with a low frequency (fL) resulting in a warble frequency. The supply voltage is obtained from the AC ring signal and the circuit is designed so that noise on the line or variation of the ringing signal can not affect correct operation of the device

Features

- On chip high voltage full wave diode bridge rectifier.
- Low current consumption, in order to allow the parallel operation of the 4 devices.
- Low external component count.
- Tone and switching frequencies adjustable by external components.
- High noise immunity due to built-in voltage current hysteresis.
- Activation voltage adjustable.
- Internal zener diodes to protect against over voltages.
- Ringer impedance adjustable with external components.

Ordering Information

Part No.	Package	Packing
TS2418CD C3	DIP-8	50pcs / Tube

Block Diagram

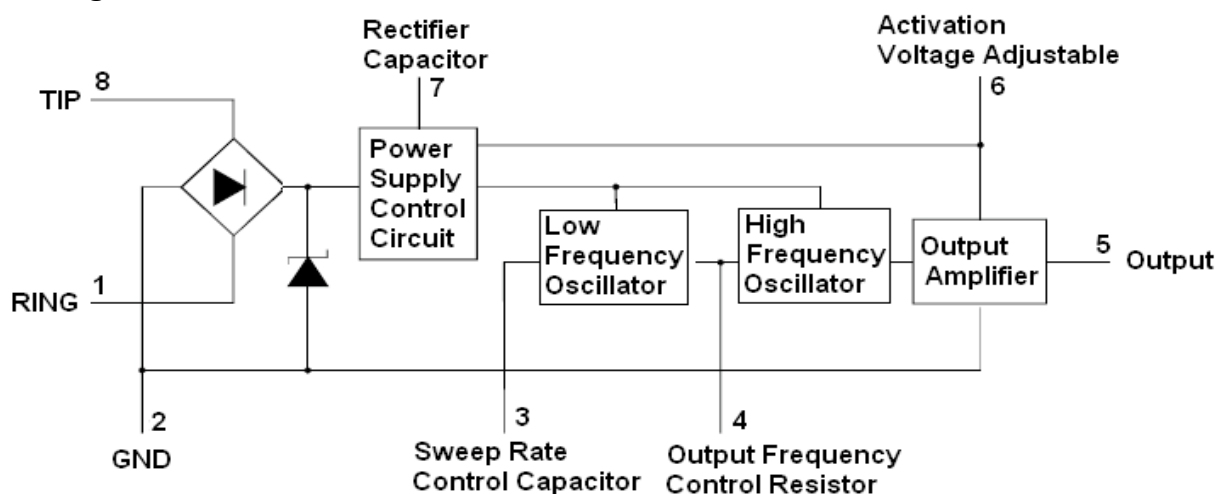

Absolute Maximum Rating

Parameter	Symbol	Value	Unit
Calling Voltage (f=50Hz) Continuous	V_{TP}	120	Vrms
Calling Voltage (f=50Hz) 5 Sec ON/10 Sec OFF	V_{TP}	200	Vrms
Supply Current	I_{CC}	22	mA
Operating Temperature	T_{OP}	0~+70	$^{\circ}C$
Storage and Junction Temperature	T_{stg}	-65~+150	$^{\circ}C$

Note: a. Maximum Rating are those values beyond which damage to the device may occur.

b. Functional operation should be restricted to the Recommended Operating Conditions.

Recommended Operating Conditions

Description	Symbol	Min	Max	Unit
Supply Voltage	V_{CC}	--	26	V
Operating Temperature	T_A	-20	+70	$^{\circ}C$

Note: This device contains protection circuitry to guard against damage due to high static voltages or electric fields. However, precautions must be taken to avoid applications of any voltage higher than maximum rated voltages to this high-impedance circuit. For proper operation, V_{IN} and V_{OUT} should be constrained to the range $GND \leq (V_{IN} \text{ or } V_{OUT}) \leq V_{CC}$. Unused inputs must always be tied to an appropriate logic voltage level (e.g., either GND or V_{CC}). Unused output must be left open.

Electrical Specifications (Ta = 25 $^{\circ}C$, unless otherwise noted)

Parameter	Symbol	Test Conditions	Min	Typ	Max	Unit
Supply Voltage	V_{CC}		--	--	26	V
Current Consumption without Load	I_{CC}	$V_s = 8.8 \text{ to } 26V$	--	1.5	1.8	mA
Activation Voltage	V_{ON}		12.2	--	13	V
Activation Voltage Range	V_{ONR}	$R_A = 1K\Omega$	8.0	--	10	V
Sustaining Voltage	V_{SUS}		8.0	--	8.8	V
Differential Resistance in Off Condition	R_D		6.4	--	--	$K\Omega$
Output Voltage Swing	V_{OUT}		--	$V_{CC}-3$	--	V
Short Circuit Current	I_{OUT}	$V_s = 26V$	--	35	--	mA

AC Operation

Output Frequency		$V_{CC} = 26V, R1 = 14K\Omega$				
f_{H1}	f_{H1}	$V_{SCR} = 0V$	--	2300	--	Hz
f_{H2}	f_{H2}	$V_{SCR} = 6V$	--	1700	--	Hz
f_{H1} Range		$R1 = 27K\Omega \text{ to } 1.7 K\Omega$	0.1	--	15	KHz
Sweep Frequency	f_L	$R1 = 14K\Omega, C1 = 100nF$	--	10	--	Hz

Test and Application Circuit

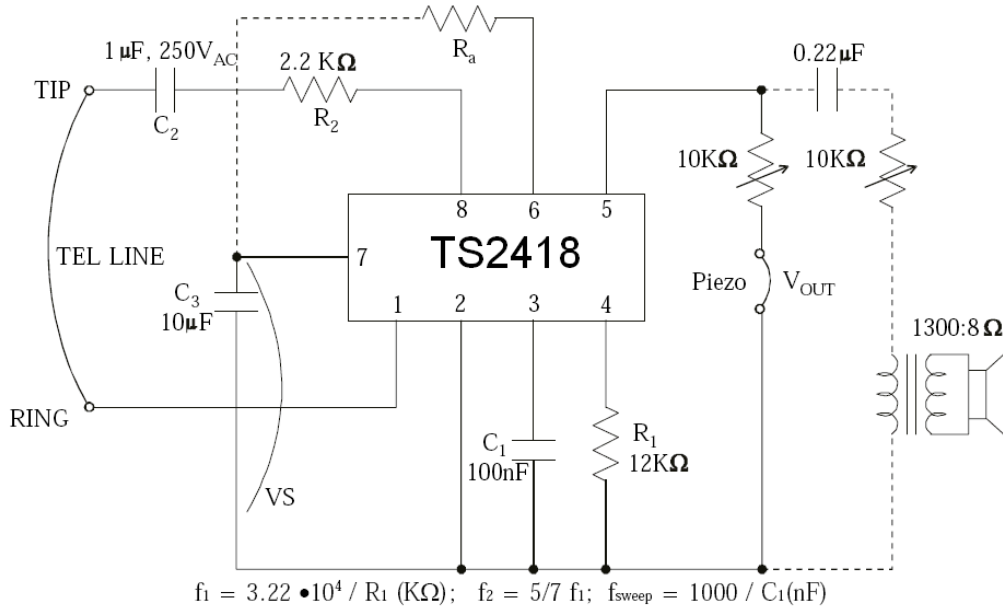

Description:

The TS2418 tone ringer derives its power supply by rectifying the AC ringing signal. It uses this power to activate two tone generators. The two tone frequencies generated are switched by internal oscillator in a fast sequence and made audible across an output amplifier in the loudspeaker; both tone frequencies and the switching frequency can be externally adjusted.

The device can drive either directly a piezo ceramic converter (buzzer) or small loudspeaker. In case of using a loudspeaker, a transformer is needed.

An internal shunt voltage regulator provides DC voltage to the output stage, low frequency oscillator, and high frequency oscillator. To protect the IC from telephone line transients, a zener Diode is included.

DIP-8 Mechanical Drawing

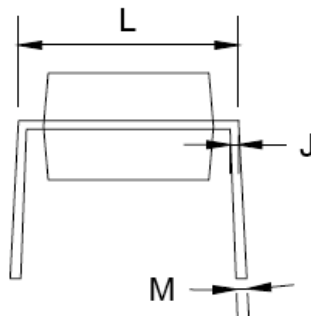
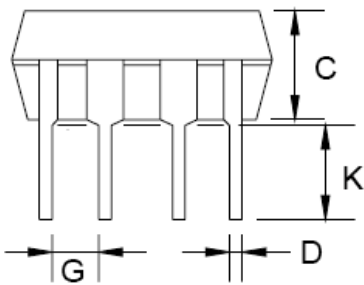
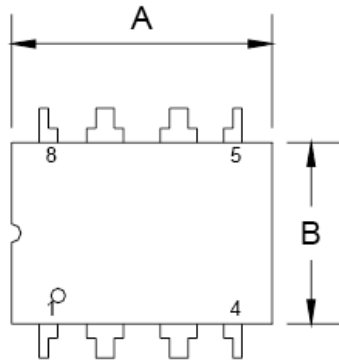

DIP-8 DIMENSION				
DIM	MILLIMETERS		INCHES	
	MIN	MAX	MIN	MAX
A	9.07	9.32	0.357	0.367
B	6.22	6.48	0.245	0.255
C	3.18	4.45	0.125	0.135
D	0.35	0.55	0.019	0.020
G	2.54 (typ)		0.10 (typ)	
J	0.29	0.31	0.011	0.012
K	3.25	3.35	0.128	0.132
L	7.75	8.00	0.305	0.315
M	-	10°	-	10°

Marking Diagram

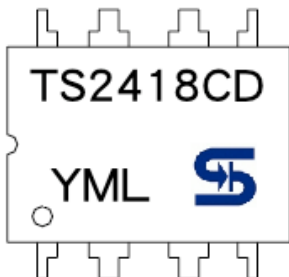

- Y** = Year Code
- M** = Month Code
(A=Jan, B=Feb, C=Mar, D=Apr, E=May, F=Jun, G=Jul, H=Aug, I=Sep, J=Oct, K=Nov, L=Dec)
- L** = Lot Code

Notice

Specifications of the products displayed herein are subject to change without notice. TSC or anyone on its behalf, assumes no responsibility or liability for any errors or inaccuracies.

Information contained herein is intended to provide a product description only. No license, express or implied, to any intellectual property rights is granted by this document. Except as provided in TSC's terms and conditions of sale for such products, TSC assumes no liability whatsoever, and disclaims any express or implied warranty, relating to sale and/or use of TSC products including liability or warranties relating to fitness for a particular purpose, merchantability, or infringement of any patent, copyright, or other intellectual property right.

The products shown herein are not designed for use in medical, life-saving, or life-sustaining applications. Customers using or selling these products for use in such applications do so at their own risk and agree to fully indemnify TSC for any damages resulting from such improper use or sale.