

## Product Specification



15mm x 27mm



### Description

The added class 1 power, +16dBm, of the BT-11, gives this module one of the best ranges in the industry. It's completely pin compatible with the lower power BT-21, and offers a second power choice on the same design.

The BT-11 module includes 16 general purpose input/output lines, several serial interface options, analog-to-digital inputs, and up to 2M bps data throughput.

The BT-11 is a surface mount PCB module that provides fully embedded, ready to use Bluetooth wireless technology. The reprogrammable flash memory contains embedded firmware for serial cable replacement using the Bluetooth SPP profile. Other popular Bluetooth profiles, such as OBEX, are also available.

Customized firmware for peripheral device interaction, power optimization, security, and other proprietary features may be supported and can be ordered pre-loaded and configured.

### Additional Documentation

- **BT Hardware Design Guide**
- **abSerial User Guide**
- **abSerial Reference Guide**

### Features

- **Bluetooth Radio**
  - Fully embedded Bluetooth v2.1+EDR with profiles
  - Class 1 radio
  - Complete RF ready module
  - Wireless data communications
  - Integrated chip antenna
  - 128-bit encryption security
  - Range up to 120m LOS
  - FCC & Bluetooth qualified
  - Integrated antenna or with coaxial external connector
- **ST Micro Cortex-M3 microprocessor up to 70MHz**
- **Memory**
  - 256K bytes flash memory
  - 48K bytes RAM memory
- **Data Rate**
  - 2M bps maximum data rate
  - Multipoint capability up to 7 slaves
- **Serial Interface**
  - UART, up to 3.25M bps
  - SPI interface
  - I2C interface
  - USB v2.0
- **General I/O**
  - 16 general purpose I/O
  - 4x12-bit A/D inputs
  - 1 DAC output
- **User Interface**
  - AT command set
  - Firmware upgrade over UART

## Software Architecture

### Lower Layer Stack

- Full Bluetooth v2.1+EDR data rate (3M bps maximum)
- Device power modes—active, sleep and deep sleep
- Wake on Bluetooth feature—optimized power consumption of host CPU
- Authentication and encryption
- Encryption key length from 8-bits to 128-bits maximum
- Persistent FLASH memory—for BD Address and radio parameter storage
- All ACL (Asynchronous Connection Less) packet types (DM1, DH1, DM3, DH3, DM5, DH5, 2-DH1, 2-DH3, 2-DH5, 3-DH1 3-DH3, 3-DH5, AUX1)
- SCO (Synchronous Connection Oriented) packet types (HV1, HV2, HV3)
- Point to multipoint and scatternet support—3 master and 7 slave links allowed (10 active links simultaneously)
- Park, sniff, and hold modes—fully supported to maximum allowed intervals
- Master slave switch—supported during connection and post connection
- Dedicated Inquiry Access Code—for improved inquiry scan performance
- Dynamic packet selection—channel quality driven data rate to optimize link performance
- Dynamic power control—interference reduction and link performance
- Bluetooth test modes—per Bluetooth specification
- 802.11b co-existence—AWMA and AFH
- Vendor specific HCI commands—to support device configuration and certification test modes

### Upper Layer Stack: Amp'ed UP

- SPP, OBEX, SDAP, GAP, and DUN protocols
- RFCOMM, SDP, and L2CAP supported
- Multipoint with 7 simultaneous slaves

### HCI Interface

- Bluetooth v2.1 specification compliant
- HCI UART transport layer (H4)

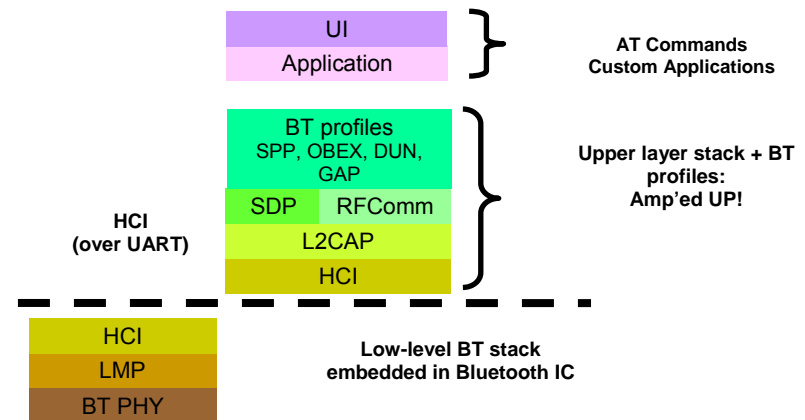

## Hardware Specifications

General Conditions ( $V_{IN}$ = 3.0V and 25°C)

### Recommended Operating Conditions

Rating	Min	Typical	Max	Unit
Operating Temperature Range	-30	-	80	°C
Supply Voltage $V_{IN}$	2.7	3.0	3.6	Volts
Signal Pin Voltage	-	3.0	-	Volts
RF Frequency	2400	-	2483.5	MHz

### Absolute Maximum Ratings

Rating	Min	Typical	Max	Unit
Storage temperature range	-55	-	+150	°C
Supply voltage, $V_{IN}$	-0.3	-	+ 3.6	Volts
I/O pin voltage, $V_{IO}$	-0.3	-	+ 4.0	Volts
RF input power	-	-	-5	dBm

### Current Consumption

Modes	Avg	Unit
<b>Typical Power Consumption</b>		
ACL data 115K Baud UART at max throughput (Master)	58.0	mA
ACL data 115K Baud UART at max throughput (Slave)	55.0	mA
Connection, no data traffic, master	26.0	mA
Connection, no data traffic, slave	34.0	mA
Connection in sniff ( $T_{sniff}$ =100ms), no data traffic, master	12.0	mA
Connection in sniff ( $T_{sniff}$ =100ms), no data traffic, slave	12.4	mA
Connection in sniff ( $T_{sniff}$ =375ms), no data traffic, master	3.0	mA
Connection in sniff ( $T_{sniff}$ =375ms), no data traffic, slave	3.5	mA
Standby, without deep sleep	21.0	mA
Standby, with deep sleep	0.240	mA
Page/Inquiry scan, deep sleep	2.4	mA

### I/O Operating Characteristics

Symbol	Parameter	Min	Max	Unit	Conditions
V <sub>IL</sub>	Low-Level Input Voltage	-	0.9	Volts	V <sub>IN</sub> , 3.0V
V <sub>IH</sub>	High-Level Input Voltage	2.1	-	Volts	V <sub>IN</sub> , 3.0V
V <sub>OL</sub>	Low-Level Output Voltage	-	0.4	Volts	V <sub>IN</sub> , 3.0V
V <sub>OH</sub>	High-Level Output Voltage	2.2	-	Volts	V <sub>IN</sub> , 3.0V
I <sub>OL</sub>	Low -Level Output Current	-	8.0	mA	V <sub>OL</sub> = 0.4 V
I <sub>OH</sub>	High-Level Output Current	-	8.0	mA	V <sub>OH</sub> = 2.2 V
R <sub>PU</sub>	Pull-up Resistor	50	150	KΩ	Resistor Turned On
R <sub>PD</sub>	Pull-down Resistor	50	150	KΩ	Resistor Turned On

### Selected RF Characteristics

Parameters	Conditions	BT Spec	Typical	Unit
Antenna load			50	ohm
<b>Radio Receiver</b>				
Sensitivity level	BER < .001 with DH5	≤ -70	-90	dBm
Maximum usable level	BER < .001 with DH1	≥ -20	-9	dBm
Input VSWR			2.5:1	
<b>Radio Transmitter</b>				
Maximum output power	50 Ω load	<+20	+16	dBm
Initial Carrier Frequency Tolerance		± 75	0	kHz
20 dB Bandwidth for modulated carrier		≤ 1000	932	kHz

### Pin Assignment

Name	Type	Pin #	Description	ALT Function
<b>UART Interface</b>				
RXD	I	8	Receive data	
TXD	O	6	Transmit data	
CTS	I	9	Clear to send (active low)	
RTS	O	10	Request to send (active low)	
<b>Boot Loader</b>				
Boot 0	I	2	Boot Loader (active high)	
<b>Power and Ground</b>				
V <sub>DD</sub>		24	V <sub>DD</sub>	
GND		23	GND	
<b>Reset</b>				
RESETN	I	3	Reset input (active low for 5 ms);	
<b>GPIO – General Purpose Input/Output</b>				
GPIO [0]	I/O	16	General Purpose Input/Output	SPI MISO
GPIO [1]	I/O	17	General Purpose Input/Output	SPI MOSI
GPIO [2]	I/O	19	General Purpose Input/Output	SPI SS
GPIO [3]	I/O	1	General Purpose Input/Output	SPI CLK
GPIO [4]	I/O	18	General Purpose Input/Output	UART 2 RXD
GPIO [5]	I/O	20	General Purpose Input/Output	UART 2 TXD
GPIO [6]	I/O	22	General Purpose Input/Output	ADC 0
GPIO [7]	I/O	13	General Purpose Input/Output	ADC 1
GPIO [8]	I/O	4	General Purpose Input/Output	ADC 2
GPIO [9]	I/O	7	General Purpose Input/Output	ADC 3
GPIO [10]	I/O	5	General Purpose Input/Output	
GPIO [11]	I/O	11	General Purpose Input/Output	I2C SCL
GPIO [12]	I/O	12	General Purpose Input/Output	I2C SDA
GPIO [13]	I/O	15	General Purpose Input/Output	
GPIO [14]	I/O	14	General Purpose Input/Output	
GPIO [15]	I/O	21	General Purpose Input/Output	DAC

**BT-11 Drawing**

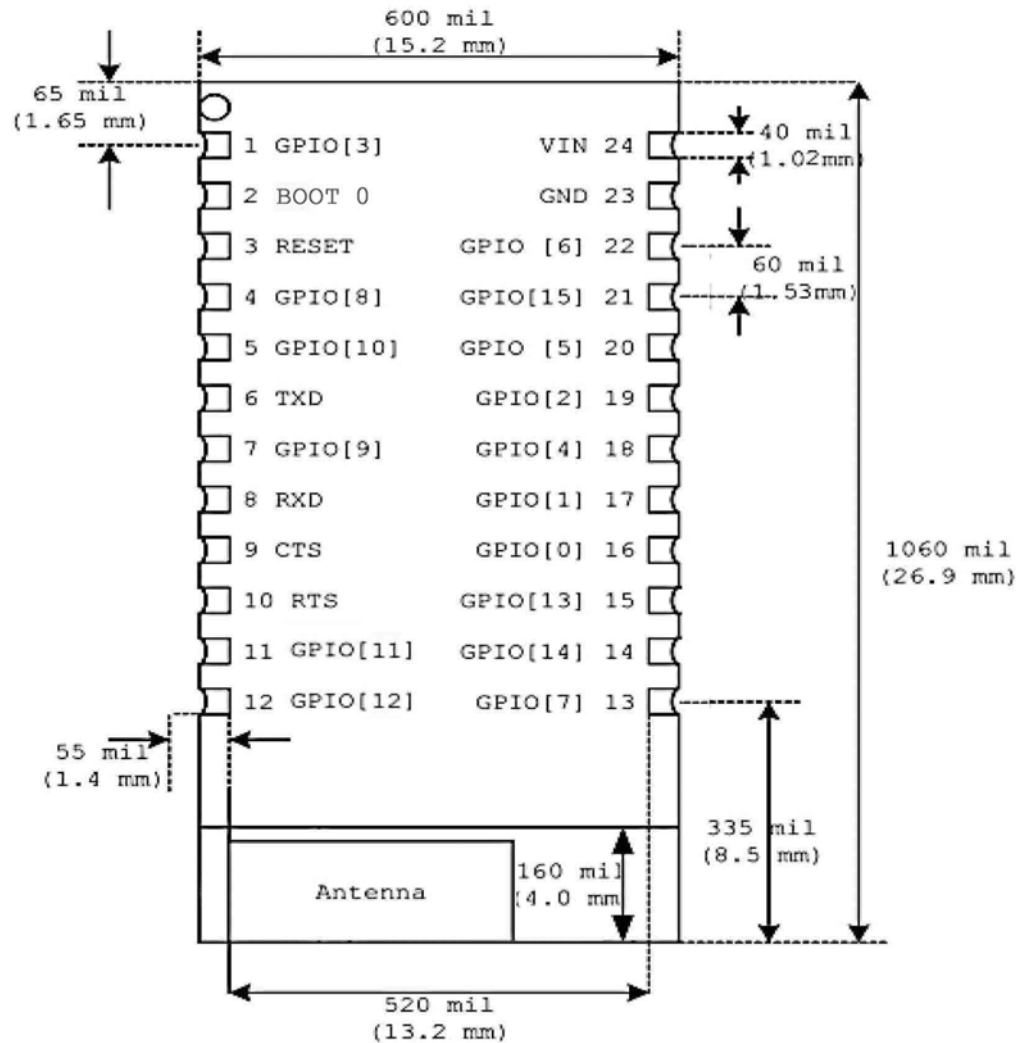

**Hardware Block Diagram**

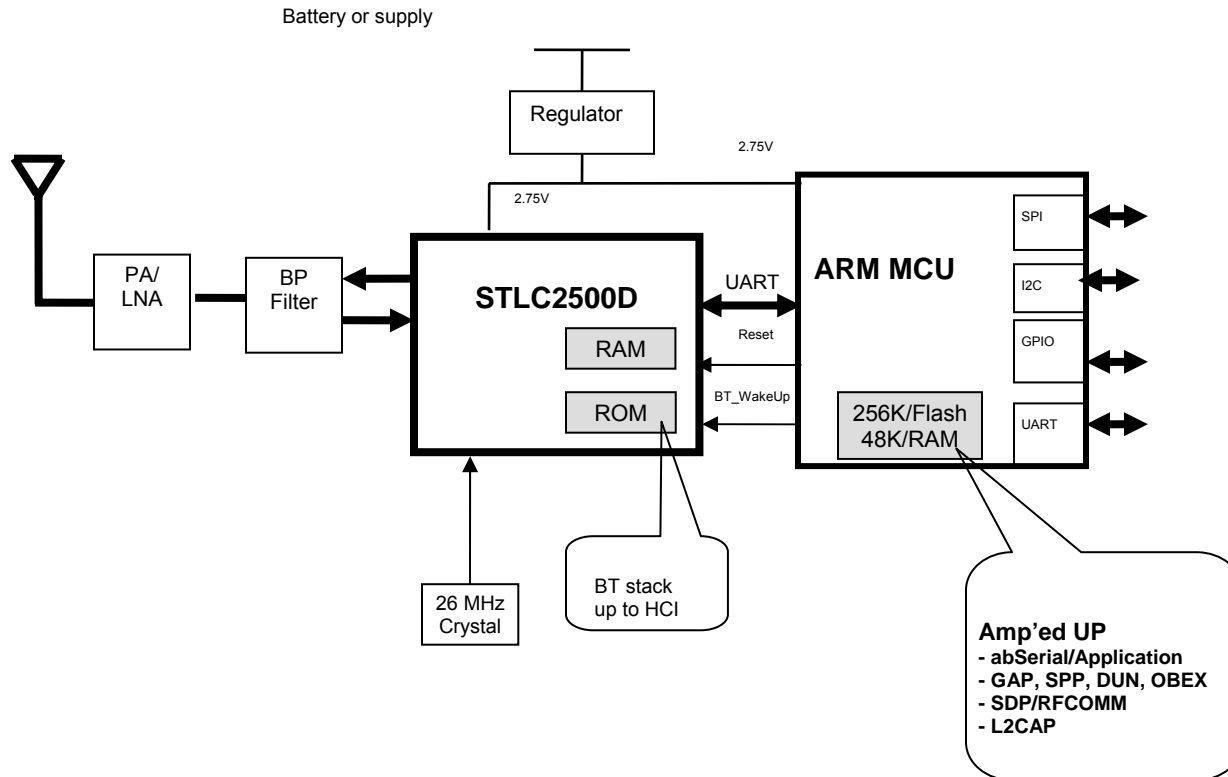

**BT-11 Bluetooth Module Block Diagram**

## Hardware Design

Amp'ed RF modules support UART, USB, SPI, I2C and GPIO hardware interfaces. Note that the usage of these interfaces is dependant upon the firmware that is loaded into the module, and is beyond the scope of this document.

### Notes

- All unused pins should be left floating; do not ground.
- All GND pins must be well grounded.
- The area around the module should be free of any ground planes, power planes, trace routings, or metal for 8 mm from the antenna in all directions.
- Traces should not be routed underneath the module.

### Module Reflow Installation

The BT-11 is a surface mount Bluetooth module supplied on a 24 pin, 6-layer PCB. The final assembly recommended reflow profiles are:

For non Pb-free applications, Sn63Pb37 solder is recommended.

- Maximum peak temperature of 208° - 210°C (below 220°C).
- Maximum rise and fall slope after liquidous of < 2°C/second.
- Maximum rise and fall slope after liquidous of < 2°C/second.
- Maximum time at liquidous of 50 – 90 seconds.

For RoHS/Pb-free applications, Sn96.5/Ag3.0/Cu0.5 solder is recommended.

- Maximum peak temperature of 230° - 240°C (below 250°C).
- Maximum rise and fall slope after liquidous of < 2°C/second.
- Maximum rise and fall slope after liquidous of < 3°C/second.
- Maximum time at liquidous of 40 – 80 seconds.



### GPIO Interface

All GPIOs are capable of sinking and sourcing 8mA of I/O current. GPIO [0] to GPIO [7] are internally pulled down with 100KΩ (nominal) resistors GPIO [8] to GPIO [15] are internally pulled up with 100KΩ (nominal) resistors.

### UART Interface

The UART is compatible with the 16550 industry standard. Four signals are provided with the UART interface. The TXD and RXD pins are used for data while the CTS and RTS pins are used for flow control.

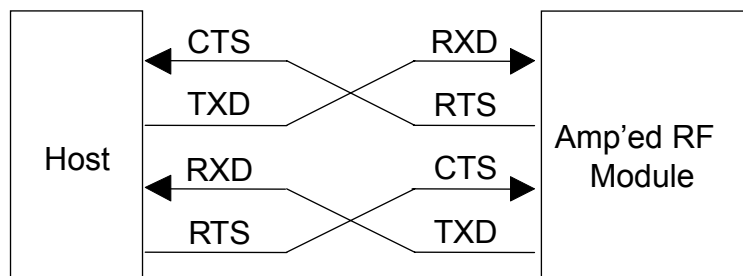

Connection to Host Device

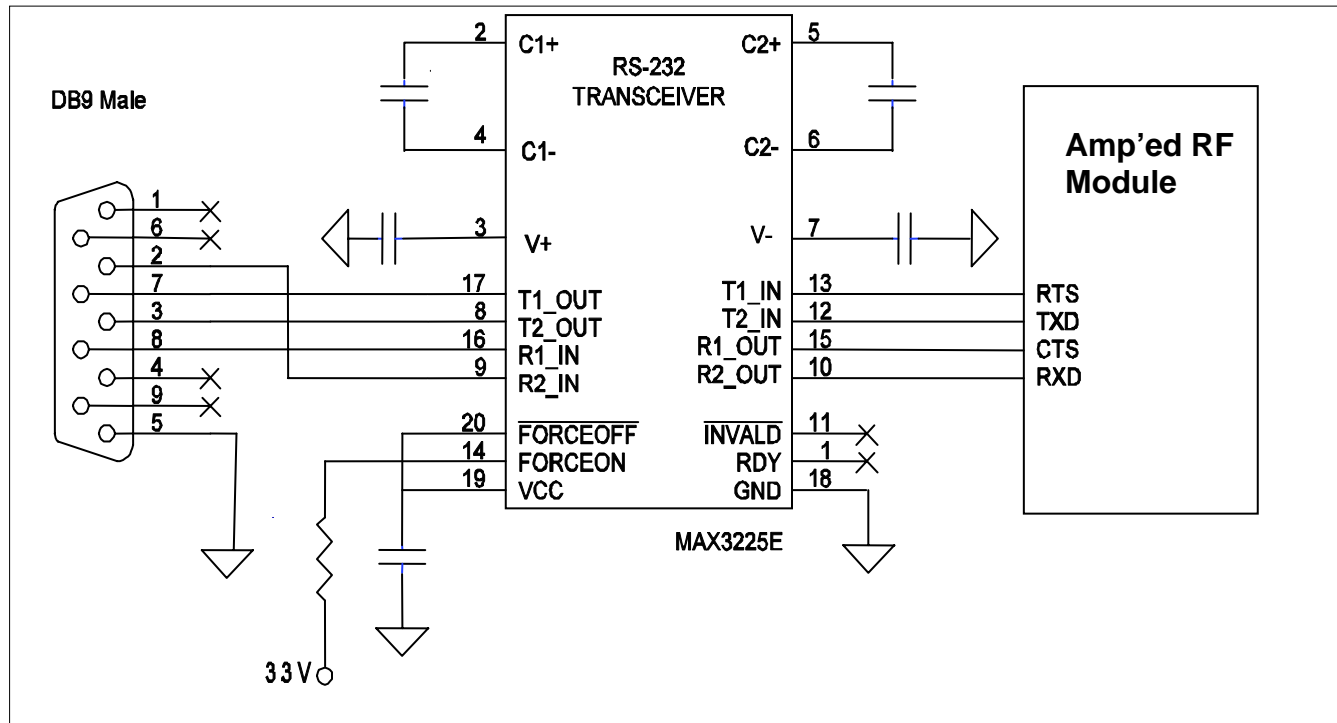

Typical RS232 Circuit

**PCB Layout Guidelines**

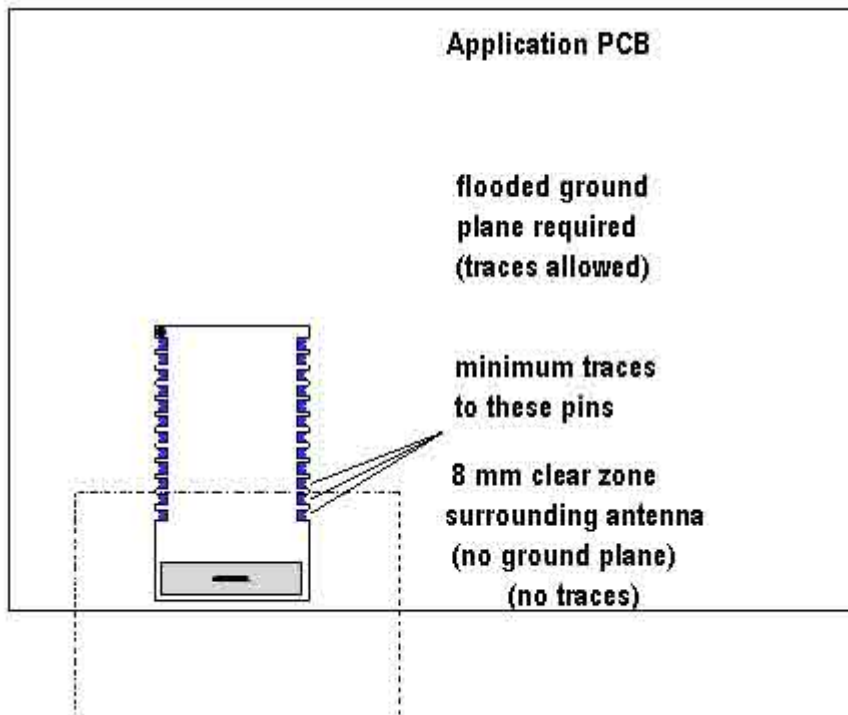

### ***FCC Regulatory Compliance***

This module has been tested and found to comply with the FCC Part 15 Rules. These limits are designed to provide reasonable protection against harmful interference in approved installations. This equipment generates, uses, and can radiate radio frequency energy and, if not installed and used in accordance the instructions, may cause harmful interference to radio communications. However, there is no guarantee that interference will not occur in a particular installation. This device complies with part 15 of the FCC Rules. Operation is subject to the following two conditions: (1) This device may not cause harmful interference, and (2) this device must accept any interference received, including interference that may cause undesired operation.

Modifications or changes to this equipment not expressly approved by Amp'ed RF may void the user's authority to operate this equipment.

### **Modular Approval**

FCC ID: WDTBTMOD1

In accordance with FCC Part 15, the BT-11 is listed above as a Modular Transmitter device.

### ***FCC Label Instructions***

The outside of final products that contain a BT-11 device must display a label referring to the enclosed module. This exterior label can use wording such as the following: "Contains Transmitter Module FCC ID: WDTBTMOD2 or "Contains FCC ID: WDTBTMOD1. Any similar wording that expresses the same meaning may be used.