



TAYCHIPST

SURFACE MOUNT RECTIFIER

SOD1F1 THRU SOD1F10

100V-1000V 1.0A

FEATURES

- Glass passivated device
- Ideal for surface mouted applications
- Low leakage current
- Metallurgically bonded construction
- High temperature soldering:
/10 seconds at terminals

Mechanical Data

Case:JEDEC SOD-123FL,molded plastic over passivated chip
 Terminals:Solder Plated, solderable per MIL-STD-750, Method 2026
 Polarity: Color band denotes cathode end
 Weight: 0.003 ounces, 0.01 gram
 Mounting position: Any

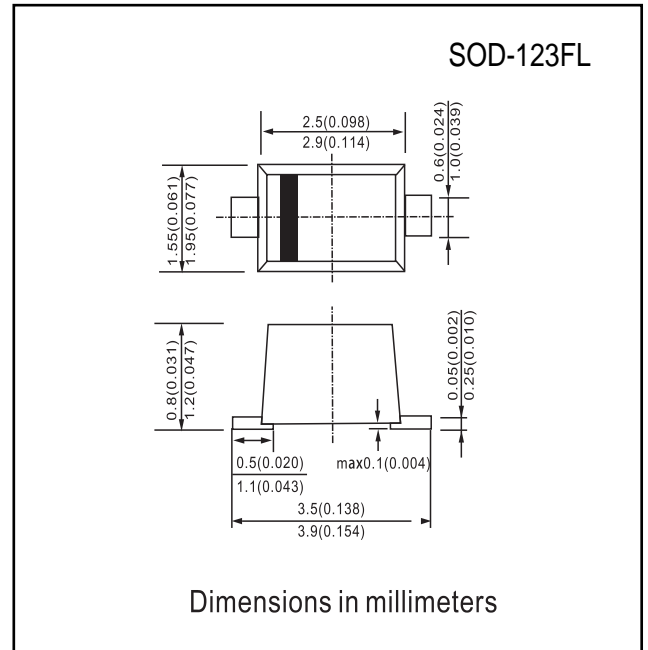

MAXIMUM RATINGS AND ELECTRICAL CHARACTERISTICS

Ratings at 25 ambient temperature unless otherwise specified.
 Single hase,half wave,60Hz,resistive or inductive load.For capactive load,derate current by 20%.

ABSOLUTE RATINGS

		SOD1F1	SOD1F2	SOD1F4	SOD1F6	SOD1F8	SOD1F10	UNITS
Device marking code		FB	FD	FG	FJ	FK	FM	
Maximum recurent peak reverse voltage	V_{RRM}	100	200	400	600	800	1000	V
Maximum RMS voltage	V_{RMS}	70	140	280	420	560	700	V
Maximum DC blocking voltage	V_{DC}	100	200	400	600	800	1000	V
Maximum average forward rectified current $T_A=65$ (NOTE 1)	$I_{(AV)}$	1.0						A
Peak forward surge current 8.3ms single half-sine-wave superimposed on rated load $T_L=25$	I_{FSM}	25						A
Typical thermal resistance (NOTE 2)	$R_{\theta JA}$	180						K/W
Maximum reverse recovery time (NOTE 3)	t_{rr}	150			250	500		ns
Operating temperature range	T_j	- 55 --- + 150						
Storage temperature range	T_{STG}	- 55 --- + 150						

NOTES:1.Averaged over any 20 ms period.

2. Thermal resistance junction to ambient, 6.0 mm² coppeer pads to each terminal.

3.Measured with $I_F=0.5A$, $I_R=1A$, $I_{rr}=0.25A$.



RATINGS AND CHARACTERISTIC CURVES

SOD1F1 THRU SOD1F10

FIG.1 – TYPICAL FORWARD CHARACTERISTIC

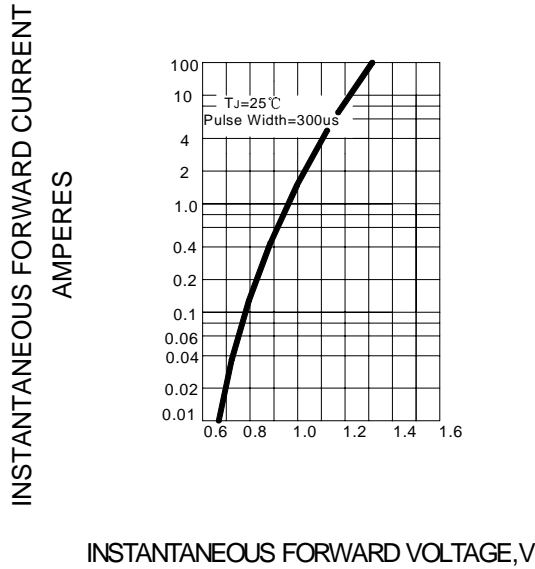

FIG.2 – TYPICAL JUNCTION CAPACITANCE

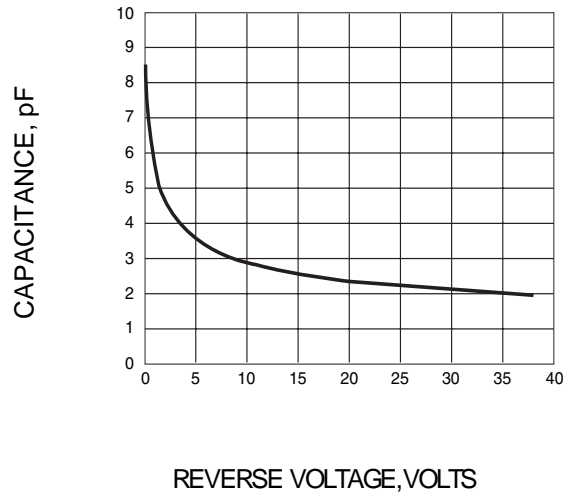

FIG.3 – TYPICAL INSTANTANEOUS REVERSE CHARACTERISTICS

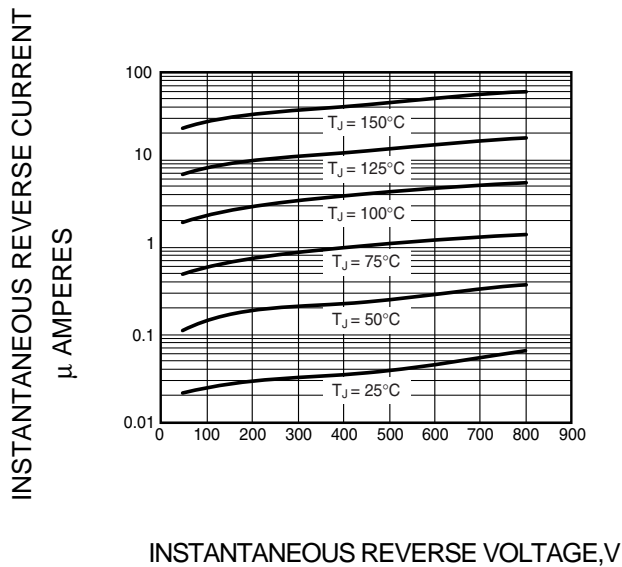

FIG.4 – FORWARD DERATING CURVE

