

**Silicon PNP Power Transistors**

**2SB705/705A/705B**

**DESCRIPTION**

- With MT-200 package
- Complement to type 2SD745/745A/745B

**APPLICATIONS**

- Audio frequency power amplifier
- Suitable for output stages of 60~120W audio amplifiers and voltage regulators

**PINNING(see Fig.2)**

PIN	DESCRIPTION
1	Base
2	Collector;connected to mounting base
3	Emitter

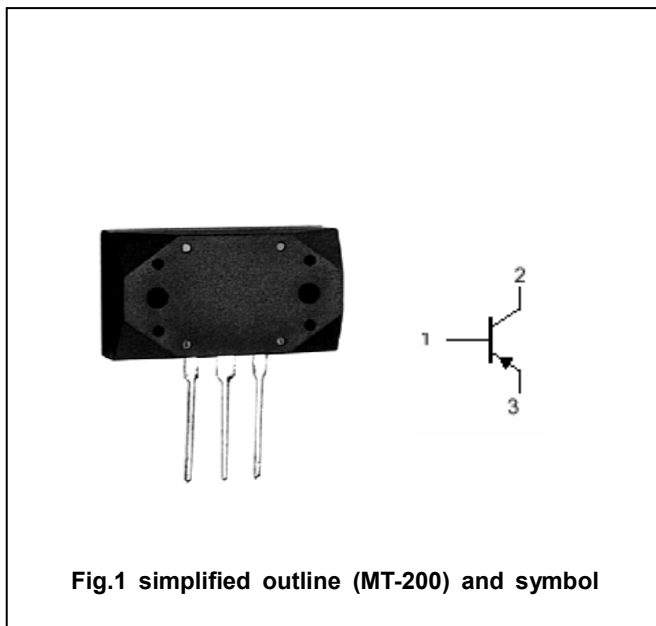

Fig.1 simplified outline (MT-200) and symbol

**Absolute maximum ratings (Ta=25℃)**

SYMBOL	PARAMETER	CONDITIONS	VALUE	UNIT
V <sub>CBO</sub>	Collector-base voltage	2SB705	-140	V
		2SB705A	-150	
		2SB705B	-160	
V <sub>CEO</sub>	Collector-emitter voltage	2SB705	-140	V
		2SB705A	-150	
		2SB705B	-160	
V <sub>EBO</sub>	Emitter-base voltage	Open collector	-5	V
I <sub>C</sub>	Collector current		-10	A
I <sub>CM</sub>	Collector current-peak		-15	A
P <sub>T</sub>	Total power dissipation	T <sub>C</sub> =25℃	120	W
T <sub>j</sub>	Junction temperature		150	℃
T <sub>stg</sub>	Storage temperature		-55~150	℃

## Silicon PNP Power Transistors

## 2SB705/705A/705B

## CHARACTERISTICS

T<sub>j</sub>=25 °C unless otherwise specified

SYMBOL	PARAMETER	CONDITIONS	MIN	TYP.	MAX	UNIT
V <sub>(BR)CEO</sub>	Collector-emitter breakdown voltage	2SB705	-140			V
		2SB705A	-150			
		2SB705B	-160			
V <sub>CEsat</sub>	Collector-emitter saturation voltage	I <sub>C</sub> =-5A; I <sub>B</sub> =-0.5 A			-1.5	V
V <sub>BEsat</sub>	Base-emitter saturation voltage	I <sub>C</sub> =-5A; I <sub>B</sub> =-0.5 A			-2.0	V
I <sub>CBO</sub>	Collector cut-off current	V <sub>CB</sub> =-140V; I <sub>E</sub> =0			-50	μA
I <sub>EBO</sub>	Emitter cut-off current	V <sub>EB</sub> =-3V; I <sub>C</sub> =0			-50	μA
h <sub>FE-1</sub>	DC current gain	I <sub>C</sub> =-50mA; V <sub>CE</sub> =-5V	20			
h <sub>FE-2</sub>	DC current gain	I <sub>C</sub> =-2A; V <sub>CE</sub> =-5V	40		200	
f <sub>T</sub>	Transition frequency	I <sub>C</sub> =-0.2A; V <sub>CE</sub> =-5V		17		MHz
C <sub>OB</sub>	Output capacitance	I <sub>E</sub> =0; V <sub>CB</sub> =-10V; f=1MHz		430		pF

◆ h<sub>FE-2</sub> classifications

S	R	Q
40-80	60-120	100-200

Silicon PNP Power Transistors

2SB705/705A/705B

PACKAGE OUTLINE

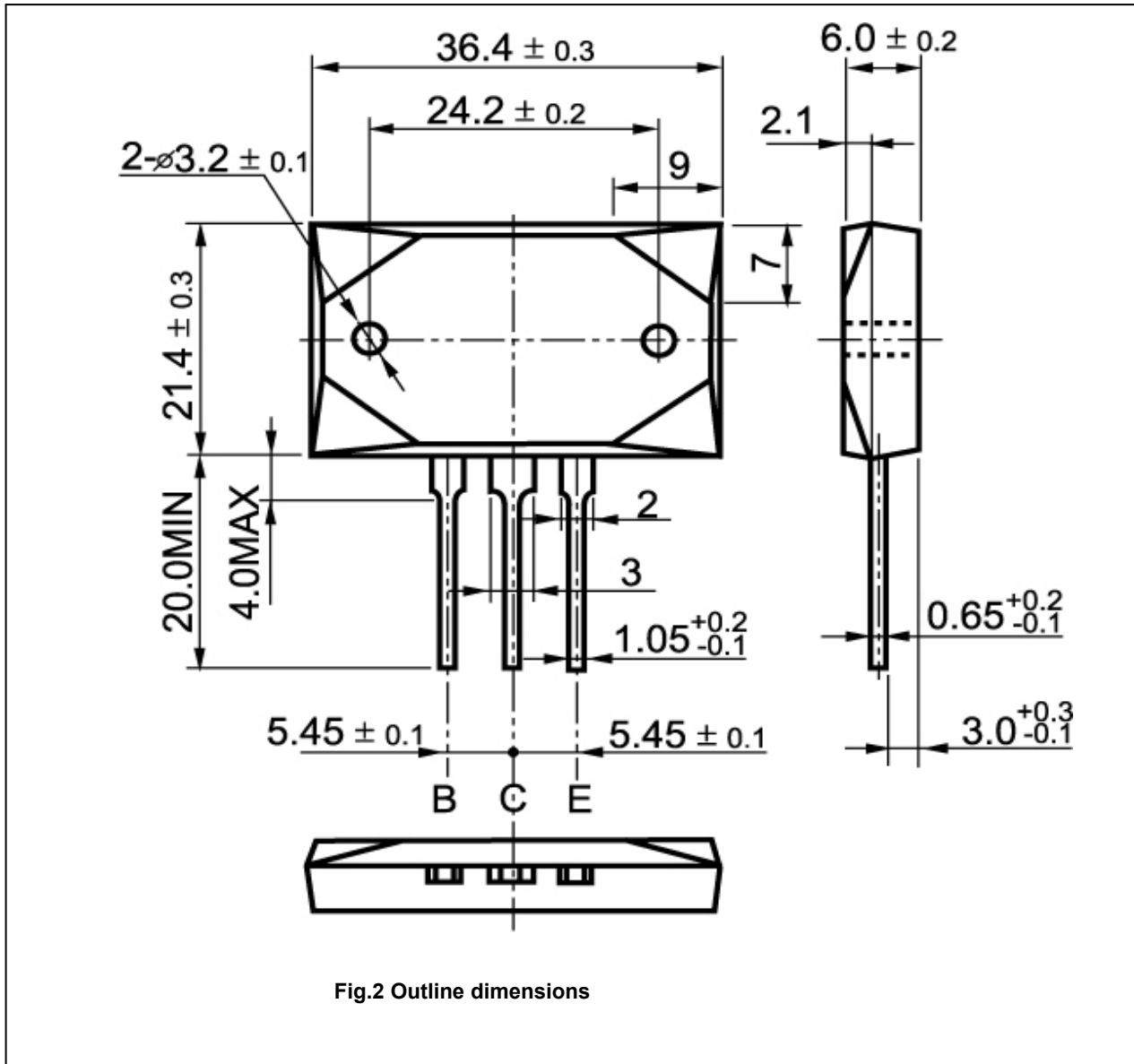

Fig.2 Outline dimensions