

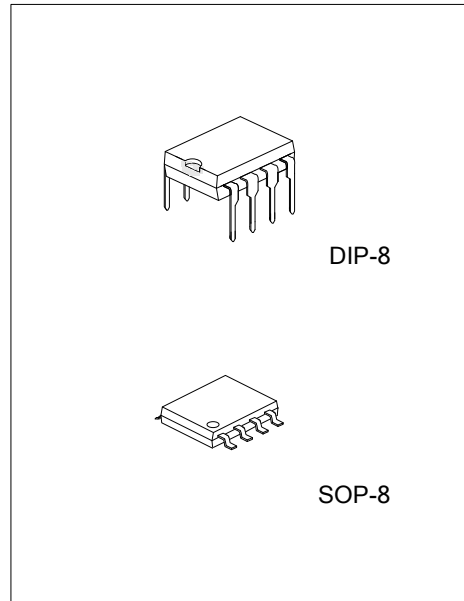

3541

CMOS IC

CLASS AB STEREO HEADPHONE DRIVER WITH MUTE



DESCRIPTION

The UTC **3541** is a class AB stereo headphone driver with Mute feature.

FEATURES

- * Built-in Mute Function
- * No Switch ON/OFF pops
- * Short-Circuit Protection
- * Low Power Consumption
- * Large Output Voltage Swing
- * High Signal-to-Noise Ratio

ORDERING INFORMATION

Ordering Number		Package	Packing
Lead Free	Halogen Free		
3541L-D08-T	3541G-D08-T	DIP-8	Tube
3541L-S08-R	3541G-S08-R	SOP-8	Tape Reel
3541L-S08-T	3541G-S08-T	SOP-8	Tube

<p>3541L-D08-T</p> <p>(1)Packing Type</p> <p>(2)Package Type</p> <p>(3)Lead Free</p>	<p>(1) R: Tape Reel, T: Tube</p> <p>(2) D08: DIP-8, S08: SOP-8</p> <p>(3) G: Halogen Free, L: Lead Free</p>
--	---

■ BLOCK DIAGRAM

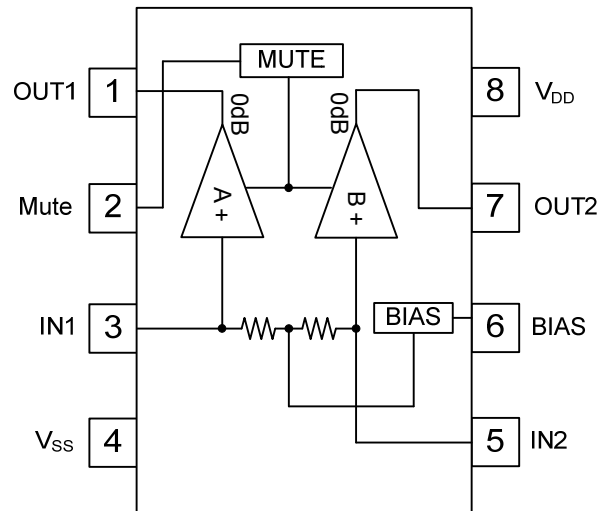

■ PIN DESCRIPTION

PIN NO.	PIN NAME	I/O	DESCRIPTION
1	OUT 1	O	Output pin for Channel A
2	Mute	I	Mute control input, high for normal operation
3	IN 1	I	Input pin for Channel A
4	V _{SS}		Power ground
5	IN 2	I	Input pin for Channel B
6	BIAS	I	Right channel bias input pin
7	OUT 2	O	Output pin for Channel B
8	V _{DD}		Power supply input

■ ABSOLUTE MAXIMUM RATINGS

PARAMETER	SYMBOL	RATINGS	UNIT
Supply Voltage	V_{DD}	7	V
Output Short-Circuit Duration ($T_A=25^\circ\text{C}$, $P_D=1\text{W}$)	$t_{SC(O)}$	20	S
Junction Temperature	T_J	150	$^\circ\text{C}$
Operating Temperature	T_{OPR}	-40 ~ +85	$^\circ\text{C}$
Storage Temperature	T_{STG}	-65 ~ +150	$^\circ\text{C}$

Note: Absolute maximum ratings are those values beyond which the device could be permanently damaged.

Absolute maximum ratings are stress ratings only and functional device operation is not implied.

■ THERMAL DATA

PARAMETER	SYMBOL	RATINGS	UNIT
Junction to Ambient (Note)	DIP-8	108	$^\circ\text{C/W}$
	SOP-8	210	
Junction to Case	DIP-8	45	$^\circ\text{C/W}$
	SOP-8	40	

Note: θ_{JA} is measured with the component mounted on a high effective thermal conductivity test board in free air.

■ ELECTRICAL CHARACTERISTICS

($V_{IN}=0\text{dBV}$, $V_{CC}=5\text{V}$, $T_A=25^\circ\text{C}$, $f=1\text{kHz}$, $R_L=32\Omega$, unless otherwise specified.)

PARAMETER	SYMBOL	TEST CONDITIONS	MIN	TYP	MAX	UNIT
Supply Voltage	V_{DD}		3.0	5.0	6.0	V
Mute Terminal Voltage	V_{TM}		0.3	0.7	1.6	V
Quiescent Current	I_Q	$V_{IN} = 0V_{RMS}$		3.5	5	mA
Mute Current	I_{MUTE}			200		μA
Voltage Gain	G_{VCL}	$V_{IN}=1V_{RMS}$, $f=1\text{kHz}$, $R_L=32\Omega$	-2	0	2	dB
Differential Channel Voltage Gain	ΔG_{VCL}		-0.5	0	0.5	dB
Channel Separation	CS	$f=1\text{kHz}$	-90	-92.5		dB
Mute Attenuation	ATT	$V_{IN} = 1V_{rms}$, $f=1\text{kHz}$, Mute=L	65	70		dB
Ripple Rejection	RR	$F_{RR} = 100\text{Hz}$, $V_{RR} = -20\text{dBV}$	50	60		dB
Output Noise Voltage	V_{NO}	$BW = 20\sim 20\text{kHz}$, $V_{IN}=0V_{RMS}$		-93	-85	dBV
Total Harmonic Distortion	THD	$BW < 120\text{kHz}$		0.03	0.1	%
Rated Output Power 1	P_{O1}	THD+N=0.1%, $BW < 120\text{kHz}$	$R_L=32\Omega$	50	55	mW
Rated Output Power 2	P_{O2}		$R_L=16\Omega$	105	110	mW

■ TEST AND APPLICATION CIRCUIT

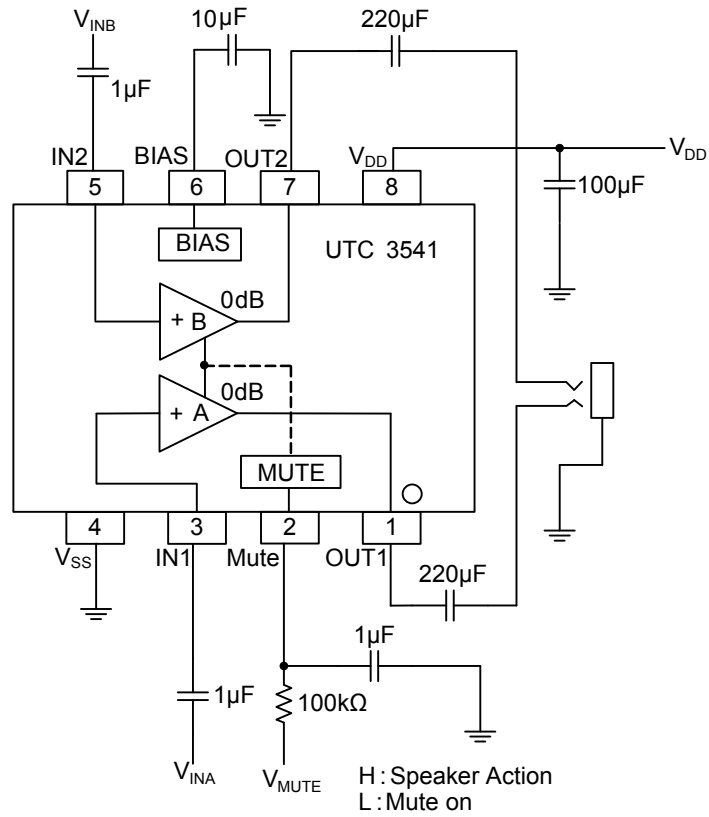

■ TYPICAL CHARACTERISTICS

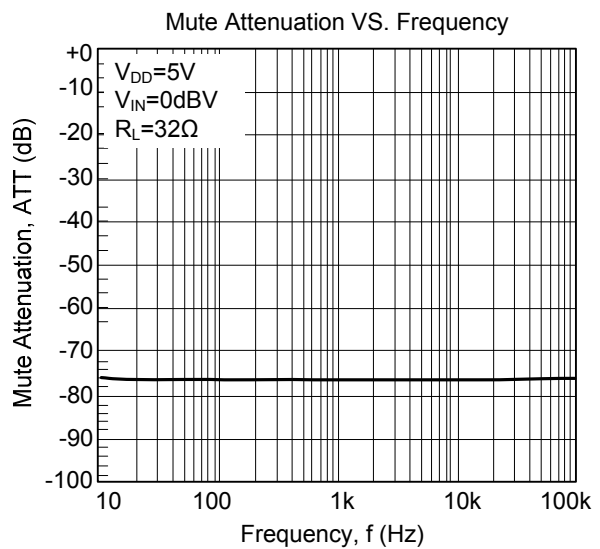
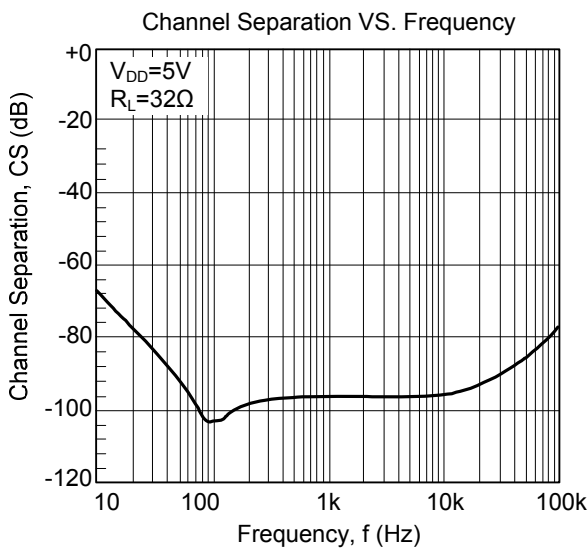
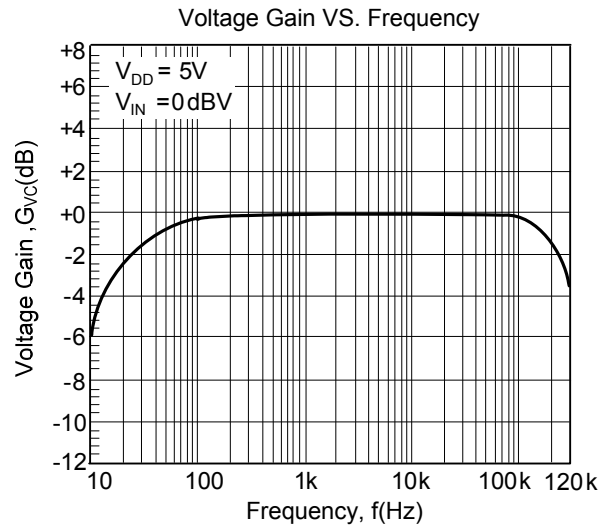
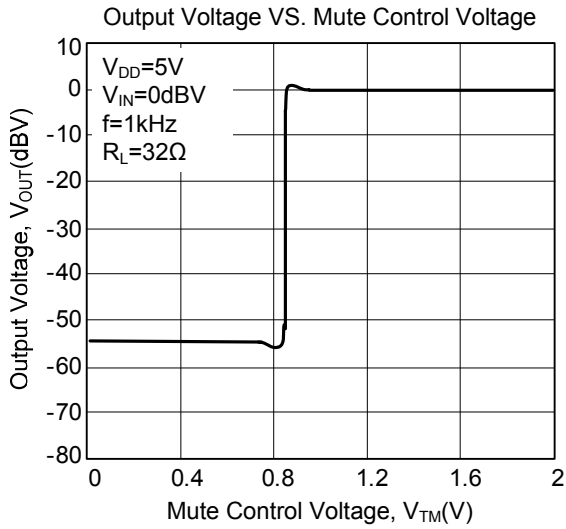
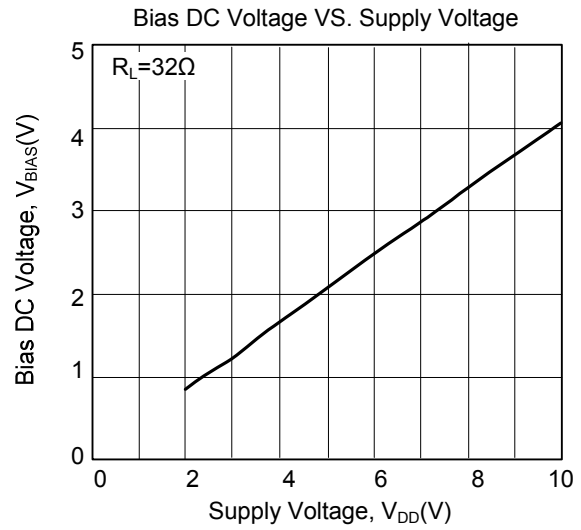
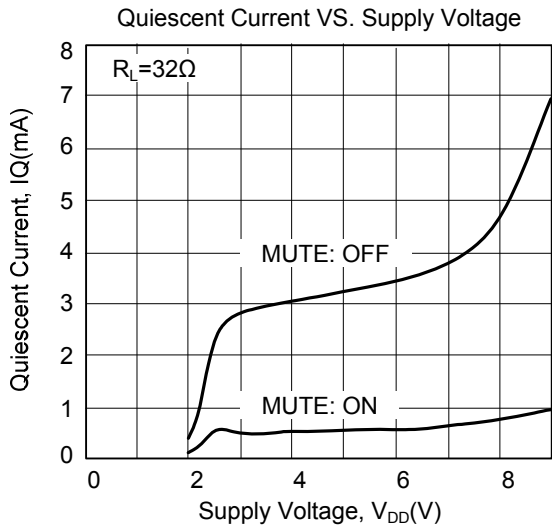

■ TYPICAL CHARACTERISTICS(Cont.)

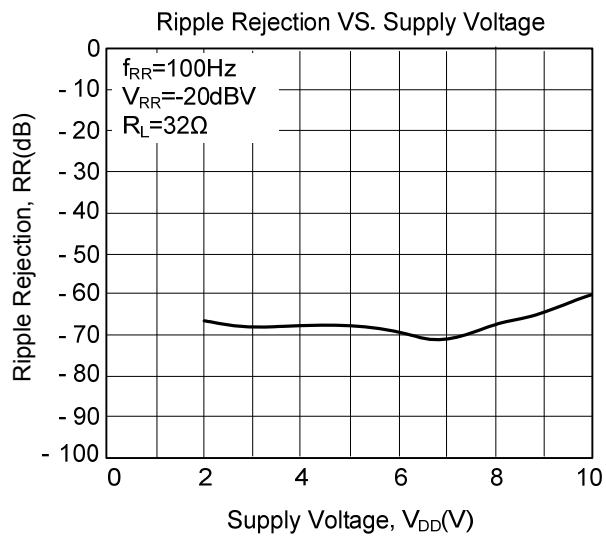

UTC assumes no responsibility for equipment failures that result from using products at values that exceed, even momentarily, rated values (such as maximum ratings, operating condition ranges, or other parameters) listed in products specifications of any and all UTC products described or contained herein. UTC products are not designed for use in life support appliances, devices or systems where malfunction of these products can be reasonably expected to result in personal injury. Reproduction in whole or in part is prohibited without the prior written consent of the copyright owner. The information presented in this document does not form part of any quotation or contract, is believed to be accurate and reliable and may be changed without notice.