

GSD

1705-2

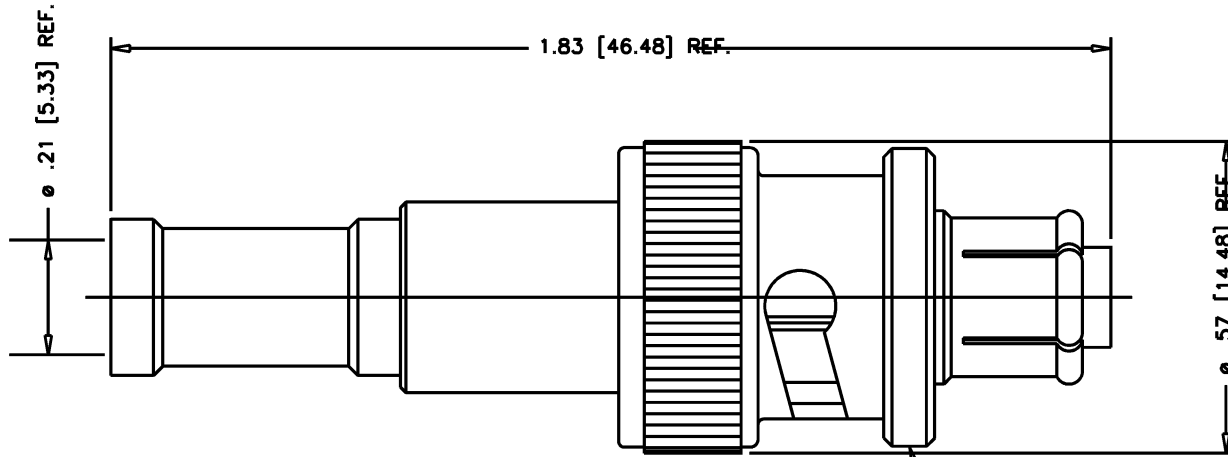

STAMP: KINGS 1705-2 YRWK (DATE CODE)

NOTES:

1. FOR USE WITH RG-58, 58A, 58C, 141 & 141A/U CABLES.
2. FOR CABLING INSTRUCTIONS SEE CP-441.
3. FOR CRIMPING USE DIE KTH-2061.
4. FOR CABLE TRIMMING USE KTJ-72 & KTD-136.
5. INTERFACE PER MIL-STD-348, FIG. 314-2.
6. MATERIALS:
 - INSULATOR: TEFLON, ASTM-D4894
 - GASKET: SIL. RUB., A-A-59588
 - K-GRIP SLEEVE: COM. BRONZE TUBE, ASTM-B135
 - SPRING WASHER & CONTACTS: BER. COP., ASTM-B196
 - ALL OTHER PARTS: BRASS, ASTM-B16
7. FINISHES:
 - CENTER CONTACT: GOLD, ASTM-B488
 - SPRING WASHER: SILVER, ASTM-B700
 - ALL OTHER METAL PARTS: KINGS TARNISH RESISTANT NICKEL FINISH (TR-5)
8. ELECTRICAL CHARACTERISTICS:
 - OPERATING VOLTAGE: 3500 VOLTS AC
 - 5000 VOLTS DC

REVISIONS

ISSUE	CHANGES
7	CN 39706 C REDRAWN DRK 11/17/06

SCALE 4:1	
APPROX SURFACE AREA	
USED ON	
REF:	
PLUG, SHV	
DRAWN DRK	DATE 11/17/06
DESIGN MJB	DATE 10/18/94
APPR.	DATE

KINGS
ELECTRONICS CO., INC.
ROCK HILL, SOUTH CAROLINA 29730

1705-2

GSD