

# HITACHI

KAOHSIUNG HITACHI  
ELECTRONICS CO.,LTD  
P.O. BOX 26-27  
2,13TH EAST ST. K.E.P.Z.  
KAOHSIUNG TAIWAN R.O.C.  
TEL:(07) 821-5811 (7 LINE)  
FAX:(07) 821-5815

FOR MESSRS : \_\_\_\_\_

DATE : May.13,2008

## CUSTOMER'S ACCEPTANCE SPECIFICATIONS

### TX14D12VM1CBA

#### C O N T E N T S

| No. | ITEM                       | SHEET No.                   | PAGE       |
|-----|----------------------------|-----------------------------|------------|
| 1   | COVER                      | 7B64PS 2701-TX14D12VM1CBA-5 | 1-1/1      |
| 2   | RECORD OF REVISION         | 7B64PS 2702-TX14D12VM1CBA-5 | 2-1/3~3/3  |
| 3   | GENERAL DATA               | 7B64PS 2703-TX14D12VM1CBA-5 | 3-1/1      |
| 4   | ABSOLUTE MAXIMUM RATINGS   | 7B64PS 2704-TX14D12VM1CBA-5 | 4-1/2~2/2  |
| 5   | ELECTRICAL CHARACTERISTICS | 7B64PS 2705-TX14D12VM1CBA-5 | 5-1/1      |
| 6   | OPTICAL CHARACTERISTICS    | 7B64PS 2706-TX14D12VM1CBA-5 | 6-1/3~3/3  |
| 7   | BLOCK DIAGRAM              | 7B64PS 2707-TX14D12VM1CBA-5 | 7-1/1      |
| 8   | INTERFACE TIMING CHART     | 7B64PS 2708-TX14D12VM1CBA-5 | 8-1/6~6/6  |
| 9   | DIMENSIONAL OUTLINE        | 7B63PS 2709-TX14D12VM1CBA-5 | 9-1/1      |
| 10  | APPEARANCE STANDARD        | 7B64PS 2710-TX14D12VM1CBA-5 | 10-1/4~4/4 |
| 11  | PRECAUTION IN DESIGN       | 7B64PS 2711-TX14D12VM1CBA-5 | 11-1/2~2/2 |
| 12  | DESIGNATION OF LOT MARK    | 7B64PS 2712-TX14D12VM1CBA-5 | 12-1/1     |
| 13  | PRECAUTION FOR USE         | 7B64PS 2713-TX14D12VM1CBA-5 | 13-1/1     |

\*When product will be discontinued, customer will be informed by HITACHI with twelve months prior to discontinuation.

ACCEPTED BY; \_\_\_\_\_

PROPOSED BY; *Dan Cheng*

|   |            |                             |      |       |
|---|------------|-----------------------------|------|-------|
| KAOHSIUNG HITACHI<br>ELECTRONICS CO.,LTD. | Sh.<br>No. | 7B64PS 2701-TX14D12VM1CBA-5 | PAGE | 1-1/1 |
|---|------------|-----------------------------|------|-------|

## RECORD OF REVISION

| DATE  | SHEET No.  | SUMMARY  |         |                      |      |              |                       |         |        |            |        |                      |       |                      |    |            |                       |       |    |       |   |   |        |      |      |      |    |   |       |   |    |   |      |   |    |       |       |       |    |        |   |   |
|---|--|--|---------|----------------------|------|--------------|-----------------------|---------|--------|------------|--------|----------------------|-------|----------------------|----|------------|-----------------------|-------|----|-------|---|---|--------|------|------|------|----|---|-------|---|----|---|------|---|----|-------|-------|-------|----|--------|---|---|
| Nov.16,'04                                      | 7B64PS 2703 -<br>TX14D12VM1CBA-2<br>PAGE 3-1/1   | Changed :<br>3.GENERAL DATA<br>(2) Module Dimensions 10.0 typ. → 10.9 typ.<br>(11) Weight : (T.B.D)g (typ.) → (160)g (typ.)  |         |                      |      |              |                       |         |        |            |        |                      |       |                      |    |            |                       |       |    |       |   |   |        |      |      |      |    |   |       |   |    |   |      |   |    |       |       |       |    |        |   |   |
|   | 7B64PS 2704 -<br>TX14D12VM1CBA-2<br>Page 4-1/2   | Changed :<br>4.1 ELECTRICAL ABSOLUTE MAXIMUM RATINGS OF LCD<br><table border="1" style="margin: 5px 0;"> <tr> <th>SYMBOL</th> <th>MIN.</th> <th>MAX.</th> </tr> <tr> <td>VI</td> <td>-0.2</td> <td>VDD+0.2</td> </tr> </table> → <table border="1" style="margin: 5px 0;"> <tr> <th>SYMBOL</th> <th>MIN.</th> <th>MAX.</th> </tr> <tr> <td>VI</td> <td>-0.3</td> <td>VDD+0.3</td> </tr> </table>   | SYMBOL  | MIN.                 | MAX. | VI           | -0.2                  | VDD+0.2 | SYMBOL | MIN.       | MAX.   | VI                   | -0.3  | VDD+0.3              |    |            |                       |       |    |       |   |   |        |      |      |      |    |   |       |   |    |   |      |   |    |       |       |       |    |        |   |   |
|   | SYMBOL   | MIN.   | MAX.    |                      |      |              |                       |         |        |            |        |                      |       |                      |    |            |                       |       |    |       |   |   |        |      |      |      |    |   |       |   |    |   |      |   |    |       |       |       |    |        |   |   |
|   | VI   | -0.2   | VDD+0.2 |                      |      |              |                       |         |        |            |        |                      |       |                      |    |            |                       |       |    |       |   |   |        |      |      |      |    |   |       |   |    |   |      |   |    |       |       |       |    |        |   |   |
|   | SYMBOL   | MIN.   | MAX.    |                      |      |              |                       |         |        |            |        |                      |       |                      |    |            |                       |       |    |       |   |   |        |      |      |      |    |   |       |   |    |   |      |   |    |       |       |       |    |        |   |   |
|   | VI   | -0.3   | VDD+0.3 |                      |      |              |                       |         |        |            |        |                      |       |                      |    |            |                       |       |    |       |   |   |        |      |      |      |    |   |       |   |    |   |      |   |    |       |       |       |    |        |   |   |
|   | 7B64PS 2705 -<br>TX14D12VM1CBA-2<br>Page 5-1/1   | Changed :<br>5.1 ELECTRICAL CHARACTERISTICS OF LCD<br>IDD : 150 mA typ. → 65 mA typ.<br>5.2 ELECTRICAL CHARACTERISTICS OF BACKLIGHT<br><table border="1" style="margin: 5px 0;"> <tr> <th>SYMBOL</th> <th>MIN.</th> <th>TYP.</th> <th>MAX.</th> </tr> <tr> <td>VL</td> <td>-</td> <td>T.B.D</td> <td>-</td> </tr> <tr> <td>fL</td> <td>-</td> <td>T.B.D</td> <td>-</td> </tr> <tr> <td>IL</td> <td>T.B.D</td> <td>T.B.D</td> <td>T.B.D</td> </tr> <tr> <td>VS</td> <td>T.B.D</td> <td>-</td> <td>-</td> </tr> </table> → <table border="1" style="margin: 5px 0;"> <tr> <th>SYMBOL</th> <th>MIN.</th> <th>TYP.</th> <th>MAX.</th> </tr> <tr> <td>VL</td> <td>-</td> <td>(760)</td> <td>-</td> </tr> <tr> <td>fL</td> <td>-</td> <td>(55)</td> <td>-</td> </tr> <tr> <td>IL</td> <td>(2.0)</td> <td>(5.0)</td> <td>(6.0)</td> </tr> <tr> <td>VS</td> <td>(1300)</td> <td>-</td> <td>-</td> </tr> </table> | SYMBOL  | MIN.                 | TYP. | MAX.         | VL                    | -       | T.B.D  | -          | fL     | -                    | T.B.D | -                    | IL | T.B.D      | T.B.D                 | T.B.D | VS | T.B.D | - | - | SYMBOL | MIN. | TYP. | MAX. | VL | - | (760) | - | fL | - | (55) | - | IL | (2.0) | (5.0) | (6.0) | VS | (1300) | - | - |
|   | SYMBOL   | MIN.   | TYP.    | MAX.                 |      |              |                       |         |        |            |        |                      |       |                      |    |            |                       |       |    |       |   |   |        |      |      |      |    |   |       |   |    |   |      |   |    |       |       |       |    |        |   |   |
| VL  | -  | T.B.D  | -       |                      |      |              |                       |         |        |            |        |                      |       |                      |    |            |                       |       |    |       |   |   |        |      |      |      |    |   |       |   |    |   |      |   |    |       |       |       |    |        |   |   |
| fL  | -  | T.B.D  | -       |                      |      |              |                       |         |        |            |        |                      |       |                      |    |            |                       |       |    |       |   |   |        |      |      |      |    |   |       |   |    |   |      |   |    |       |       |       |    |        |   |   |
| IL  | T.B.D  | T.B.D  | T.B.D   |                      |      |              |                       |         |        |            |        |                      |       |                      |    |            |                       |       |    |       |   |   |        |      |      |      |    |   |       |   |    |   |      |   |    |       |       |       |    |        |   |   |
| VS  | T.B.D  | -  | -       |                      |      |              |                       |         |        |            |        |                      |       |                      |    |            |                       |       |    |       |   |   |        |      |      |      |    |   |       |   |    |   |      |   |    |       |       |       |    |        |   |   |
| SYMBOL  | MIN.   | TYP.   | MAX.    |                      |      |              |                       |         |        |            |        |                      |       |                      |    |            |                       |       |    |       |   |   |        |      |      |      |    |   |       |   |    |   |      |   |    |       |       |       |    |        |   |   |
| VL  | -  | (760)  | -       |                      |      |              |                       |         |        |            |        |                      |       |                      |    |            |                       |       |    |       |   |   |        |      |      |      |    |   |       |   |    |   |      |   |    |       |       |       |    |        |   |   |
| fL  | -  | (55)   | -       |                      |      |              |                       |         |        |            |        |                      |       |                      |    |            |                       |       |    |       |   |   |        |      |      |      |    |   |       |   |    |   |      |   |    |       |       |       |    |        |   |   |
| IL  | (2.0)  | (5.0)  | (6.0)   |                      |      |              |                       |         |        |            |        |                      |       |                      |    |            |                       |       |    |       |   |   |        |      |      |      |    |   |       |   |    |   |      |   |    |       |       |       |    |        |   |   |
| VS  | (1300)   | -  | -       |                      |      |              |                       |         |        |            |        |                      |       |                      |    |            |                       |       |    |       |   |   |        |      |      |      |    |   |       |   |    |   |      |   |    |       |       |       |    |        |   |   |
| 7B64PS 2706 -<br>TX14D12VM1CBA-2<br>Page 6-1/3  | Changed :<br>Note 1 : ICFL Current : (T.B.D)mA → (5.0)mA   |  |         |                      |      |              |                       |         |        |            |        |                      |       |                      |    |            |                       |       |    |       |   |   |        |      |      |      |    |   |       |   |    |   |      |   |    |       |       |       |    |        |   |   |
| 7B64PS 2706 -<br>TX14D12VM1CBA-2<br>Page 6-3/3  | Changed :<br>NOTE : IL=(T.B.D)mA → IL=(5.0)mA  |  |         |                      |      |              |                       |         |        |            |        |                      |       |                      |    |            |                       |       |    |       |   |   |        |      |      |      |    |   |       |   |    |   |      |   |    |       |       |       |    |        |   |   |
| 7B64PS 2708 -<br>TX14D12VM1CBA-2<br>Page 8-2/5  | Revised the data of the 8.2 INTERFACE TIMING   |  |         |                      |      |              |                       |         |        |            |        |                      |       |                      |    |            |                       |       |    |       |   |   |        |      |      |      |    |   |       |   |    |   |      |   |    |       |       |       |    |        |   |   |
| 7B64PS 2708 -<br>TX14D12VM1CBA-2<br>Page 8-4/5  | Revised all page   |  |         |                      |      |              |                       |         |        |            |        |                      |       |                      |    |            |                       |       |    |       |   |   |        |      |      |      |    |   |       |   |    |   |      |   |    |       |       |       |    |        |   |   |
| 7B63PS 2709 -<br>TX14D12VM1CBA-2<br>Page 9-1/1  | Revised all page   |  |         |                      |      |              |                       |         |        |            |        |                      |       |                      |    |            |                       |       |    |       |   |   |        |      |      |      |    |   |       |   |    |   |      |   |    |       |       |       |    |        |   |   |
| 7B64PS 2710 -<br>TX14D12VM1CBA-2<br>Page 10-2/4 | Changed :<br>Dot Defect<br><table border="1" style="margin: 5px 0;"> <tr> <td>Sparkle mode</td> <td>2 dots</td> </tr> <tr> <td colspan="2" style="text-align: center;">Total (Note.(3)-(f))</td> </tr> </table> → <table border="1" style="margin: 5px 0;"> <tr> <td>Sparkle mode</td> <td>2 dots (Note.(3)-(f))</td> </tr> <tr> <td colspan="2" style="text-align: center;">Total</td> </tr> </table><br><table border="1" style="margin: 5px 0;"> <tr> <td>Black mode</td> <td>2 dots</td> </tr> <tr> <td colspan="2" style="text-align: center;">Total (Note.(3)-(f))</td> </tr> <tr> <td colspan="2" style="text-align: center;">Total (Note.(3)-(f))</td> </tr> </table> → <table border="1" style="margin: 5px 0;"> <tr> <td>Black mode</td> <td>2 dots (Note.(3)-(f))</td> </tr> <tr> <td colspan="2" style="text-align: center;">Total</td> </tr> <tr> <td colspan="2" style="text-align: center;">Total</td> </tr> </table> | Sparkle mode   | 2 dots  | Total (Note.(3)-(f)) |      | Sparkle mode | 2 dots (Note.(3)-(f)) | Total   |        | Black mode | 2 dots | Total (Note.(3)-(f)) |       | Total (Note.(3)-(f)) |    | Black mode | 2 dots (Note.(3)-(f)) | Total |    | Total |   |   |        |      |      |      |    |   |       |   |    |   |      |   |    |       |       |       |    |        |   |   |
| Sparkle mode                                    | 2 dots   |  |         |                      |      |              |                       |         |        |            |        |                      |       |                      |    |            |                       |       |    |       |   |   |        |      |      |      |    |   |       |   |    |   |      |   |    |       |       |       |    |        |   |   |
| Total (Note.(3)-(f))                            |  |  |         |                      |      |              |                       |         |        |            |        |                      |       |                      |    |            |                       |       |    |       |   |   |        |      |      |      |    |   |       |   |    |   |      |   |    |       |       |       |    |        |   |   |
| Sparkle mode                                    | 2 dots (Note.(3)-(f))  |  |         |                      |      |              |                       |         |        |            |        |                      |       |                      |    |            |                       |       |    |       |   |   |        |      |      |      |    |   |       |   |    |   |      |   |    |       |       |       |    |        |   |   |
| Total   |  |  |         |                      |      |              |                       |         |        |            |        |                      |       |                      |    |            |                       |       |    |       |   |   |        |      |      |      |    |   |       |   |    |   |      |   |    |       |       |       |    |        |   |   |
| Black mode                                      | 2 dots   |  |         |                      |      |              |                       |         |        |            |        |                      |       |                      |    |            |                       |       |    |       |   |   |        |      |      |      |    |   |       |   |    |   |      |   |    |       |       |       |    |        |   |   |
| Total (Note.(3)-(f))                            |  |  |         |                      |      |              |                       |         |        |            |        |                      |       |                      |    |            |                       |       |    |       |   |   |        |      |      |      |    |   |       |   |    |   |      |   |    |       |       |       |    |        |   |   |
| Total (Note.(3)-(f))                            |  |  |         |                      |      |              |                       |         |        |            |        |                      |       |                      |    |            |                       |       |    |       |   |   |        |      |      |      |    |   |       |   |    |   |      |   |    |       |       |       |    |        |   |   |
| Black mode                                      | 2 dots (Note.(3)-(f))  |  |         |                      |      |              |                       |         |        |            |        |                      |       |                      |    |            |                       |       |    |       |   |   |        |      |      |      |    |   |       |   |    |   |      |   |    |       |       |       |    |        |   |   |
| Total   |  |  |         |                      |      |              |                       |         |        |            |        |                      |       |                      |    |            |                       |       |    |       |   |   |        |      |      |      |    |   |       |   |    |   |      |   |    |       |       |       |    |        |   |   |
| Total   |  |  |         |                      |      |              |                       |         |        |            |        |                      |       |                      |    |            |                       |       |    |       |   |   |        |      |      |      |    |   |       |   |    |   |      |   |    |       |       |       |    |        |   |   |

## RECORD OF REVISION

| DATE            | SHEET No.                                      | SUMMARY  |         |         |               |                         |      |               |               |                         |          |    |      |  |      |    |                 |    |   |        |        |        |     |                |      |   |        |        |       |     |      |        |           |      |      |      |      |                 |    |   |    |    |    |    |                 |                         |   |      |      |      |     |                          |   |      |      |      |                |                           |   |      |      |      |     |                            |   |      |      |     |
|-----------------|--|--|---------|---------|---------------|-------------------------|------|---------------|---------------|-------------------------|----------|----|------|--|------|----|-----------------|----|---|--------|--------|--------|-----|----------------|------|---|--------|--------|-------|-----|------|--------|-----------|------|------|------|------|-----------------|----|---|----|----|----|----|-----------------|-------------------------|---|------|------|------|-----|--------------------------|---|------|------|------|----------------|---------------------------|---|------|------|------|-----|----------------------------|---|------|------|-----|
| Jun.02,'06      | 7B64PS 2704 -<br>TX14D12VM1CBA-3<br>Page 4-1/2 | <b>4.2 ENVIRONMENTAL ABSOLUTE MAXIMUM RATINGS</b><br>Revised :<br><table border="1" style="width: 100%; border-collapse: collapse; margin-bottom: 5px;"> <thead> <tr> <th style="width: 50%;">ITEM</th> <th>COMMENT</th> </tr> </thead> <tbody> <tr> <td>CFL Life Time</td> <td>At 25°C , IL=4.0mA max.</td> </tr> </tbody> </table> <div style="text-align: center;">↓</div> <table border="1" style="width: 100%; border-collapse: collapse;"> <thead> <tr> <th style="width: 50%;">ITEM</th> <th>COMMENT</th> </tr> </thead> <tbody> <tr> <td>CFL Life Time</td> <td>At 25°C , IL=5.0mA max.</td> </tr> </tbody> </table>   | ITEM    | COMMENT | CFL Life Time | At 25°C , IL=4.0mA max. | ITEM | COMMENT       | CFL Life Time | At 25°C , IL=5.0mA max. |          |    |      |  |      |    |                 |    |   |        |        |        |     |                |      |   |        |        |       |     |      |        |           |      |      |      |      |                 |    |   |    |    |    |    |                 |                         |   |      |      |      |     |                          |   |      |      |      |                |                           |   |      |      |      |     |                            |   |      |      |     |
| ITEM            | COMMENT  |  |         |         |               |                         |      |               |               |                         |          |    |      |  |      |    |                 |    |   |        |        |        |     |                |      |   |        |        |       |     |      |        |           |      |      |      |      |                 |    |   |    |    |    |    |                 |                         |   |      |      |      |     |                          |   |      |      |      |                |                           |   |      |      |      |     |                            |   |      |      |     |
| CFL Life Time   | At 25°C , IL=4.0mA max.                        |  |         |         |               |                         |      |               |               |                         |          |    |      |  |      |    |                 |    |   |        |        |        |     |                |      |   |        |        |       |     |      |        |           |      |      |      |      |                 |    |   |    |    |    |    |                 |                         |   |      |      |      |     |                          |   |      |      |      |                |                           |   |      |      |      |     |                            |   |      |      |     |
| ITEM            | COMMENT  |  |         |         |               |                         |      |               |               |                         |          |    |      |  |      |    |                 |    |   |        |        |        |     |                |      |   |        |        |       |     |      |        |           |      |      |      |      |                 |    |   |    |    |    |    |                 |                         |   |      |      |      |     |                          |   |      |      |      |                |                           |   |      |      |      |     |                            |   |      |      |     |
| CFL Life Time   | At 25°C , IL=5.0mA max.                        |  |         |         |               |                         |      |               |               |                         |          |    |      |  |      |    |                 |    |   |        |        |        |     |                |      |   |        |        |       |     |      |        |           |      |      |      |      |                 |    |   |    |    |    |    |                 |                         |   |      |      |      |     |                          |   |      |      |      |                |                           |   |      |      |      |     |                            |   |      |      |     |
| Jun.08,'07      | 7B64PS 2703-<br>TX14D12VM1CBA-4<br>Page 3-1/1  | <b>3. GENERAL DATA</b><br>Revised :<br>(2) Module Dimensions 131.0(W)mm x 102.0(H)mm x 10.9(D)mm typ.<br><div style="text-align: center;">↓</div> (2) Module Dimensions 131.0(W)mm x 102.2(H)mm x 10.9(D)mm typ.   |         |         |               |                         |      |               |               |                         |          |    |      |  |      |    |                 |    |   |        |        |        |     |                |      |   |        |        |       |     |      |        |           |      |      |      |      |                 |    |   |    |    |    |    |                 |                         |   |      |      |      |     |                          |   |      |      |      |                |                           |   |      |      |      |     |                            |   |      |      |     |
|                 | 7B64PS 2705-<br>TX14D12VM1CBA-4<br>Page 5-1/3  | <b>5.1 ELECTRICAL CHARACTERISTICS OF LCD</b><br>Revised :<br><table border="1" style="width: 100%; border-collapse: collapse; margin-bottom: 5px;"> <thead> <tr> <th style="width: 20%;">ITEM</th> <th style="width: 20%;">SYMBOL</th> <th style="width: 10%;">CONDITION</th> <th style="width: 10%;">MIN.</th> <th style="width: 10%;">TYP.</th> <th style="width: 10%;">MAX.</th> <th style="width: 10%;">UNIT</th> </tr> </thead> <tbody> <tr> <td>Vsync Frequency</td> <td>fV</td> <td style="text-align: center;">-</td> <td style="text-align: center;">(52)</td> <td style="text-align: center;">60</td> <td style="text-align: center;">(68)</td> <td style="text-align: center;">Hz</td> </tr> <tr> <td>Hsync Frequency</td> <td>fH</td> <td style="text-align: center;">-</td> <td style="text-align: center;">(13.1)</td> <td style="text-align: center;">(15.2)</td> <td style="text-align: center;">(17.7)</td> <td style="text-align: center;">kHz</td> </tr> <tr> <td>DCLK Frequency</td> <td>fCLK</td> <td style="text-align: center;">-</td> <td style="text-align: center;">(4.85)</td> <td style="text-align: center;">(5.85)</td> <td style="text-align: center;">(7.0)</td> <td style="text-align: center;">MHz</td> </tr> </tbody> </table> <table border="1" style="width: 100%; border-collapse: collapse;"> <thead> <tr> <th style="width: 20%;">ITEM</th> <th style="width: 20%;">SYMBOL</th> <th style="width: 10%;">CONDITION</th> <th style="width: 10%;">MIN.</th> <th style="width: 10%;">TYP.</th> <th style="width: 10%;">MAX.</th> <th style="width: 10%;">UNIT</th> </tr> </thead> <tbody> <tr> <td>Vsync Frequency</td> <td>fV</td> <td style="text-align: center;">-</td> <td style="text-align: center;">52</td> <td style="text-align: center;">60</td> <td style="text-align: center;">68</td> <td style="text-align: center;">Hz</td> </tr> <tr> <td rowspan="2">Hsync Frequency</td> <td>fH for VGA display mode</td> <td style="text-align: center;">-</td> <td style="text-align: center;">25.3</td> <td style="text-align: center;">29.5</td> <td style="text-align: center;">36.1</td> <td rowspan="2" style="text-align: center;">kHz</td> </tr> <tr> <td>fH for QVGA display mode</td> <td style="text-align: center;">-</td> <td style="text-align: center;">13.1</td> <td style="text-align: center;">15.2</td> <td style="text-align: center;">17.7</td> </tr> <tr> <td rowspan="2">DCLK Frequency</td> <td>fCLK for VGA display mode</td> <td style="text-align: center;">-</td> <td style="text-align: center;">17.2</td> <td style="text-align: center;">20.9</td> <td style="text-align: center;">26.7</td> <td rowspan="2" style="text-align: center;">MHz</td> </tr> <tr> <td>fCLK for QVGA display mode</td> <td style="text-align: center;">-</td> <td style="text-align: center;">4.85</td> <td style="text-align: center;">5.85</td> <td style="text-align: center;">7.0</td> </tr> </tbody> </table> | ITEM    | SYMBOL  | CONDITION     | MIN.                    | TYP. | MAX.          | UNIT          | Vsync Frequency         | fV       | -  | (52) | 60   | (68) | Hz | Hsync Frequency | fH | - | (13.1) | (15.2) | (17.7) | kHz | DCLK Frequency | fCLK | - | (4.85) | (5.85) | (7.0) | MHz | ITEM | SYMBOL | CONDITION | MIN. | TYP. | MAX. | UNIT | Vsync Frequency | fV | - | 52 | 60 | 68 | Hz | Hsync Frequency | fH for VGA display mode | - | 25.3 | 29.5 | 36.1 | kHz | fH for QVGA display mode | - | 13.1 | 15.2 | 17.7 | DCLK Frequency | fCLK for VGA display mode | - | 17.2 | 20.9 | 26.7 | MHz | fCLK for QVGA display mode | - | 4.85 | 5.85 | 7.0 |
| ITEM            | SYMBOL   | CONDITION  | MIN.    | TYP.    | MAX.          | UNIT                    |      |               |               |                         |          |    |      |  |      |    |                 |    |   |        |        |        |     |                |      |   |        |        |       |     |      |        |           |      |      |      |      |                 |    |   |    |    |    |    |                 |                         |   |      |      |      |     |                          |   |      |      |      |                |                           |   |      |      |      |     |                            |   |      |      |     |
| Vsync Frequency | fV   | -  | (52)    | 60      | (68)          | Hz                      |      |               |               |                         |          |    |      |  |      |    |                 |    |   |        |        |        |     |                |      |   |        |        |       |     |      |        |           |      |      |      |      |                 |    |   |    |    |    |    |                 |                         |   |      |      |      |     |                          |   |      |      |      |                |                           |   |      |      |      |     |                            |   |      |      |     |
| Hsync Frequency | fH   | -  | (13.1)  | (15.2)  | (17.7)        | kHz                     |      |               |               |                         |          |    |      |  |      |    |                 |    |   |        |        |        |     |                |      |   |        |        |       |     |      |        |           |      |      |      |      |                 |    |   |    |    |    |    |                 |                         |   |      |      |      |     |                          |   |      |      |      |                |                           |   |      |      |      |     |                            |   |      |      |     |
| DCLK Frequency  | fCLK   | -  | (4.85)  | (5.85)  | (7.0)         | MHz                     |      |               |               |                         |          |    |      |  |      |    |                 |    |   |        |        |        |     |                |      |   |        |        |       |     |      |        |           |      |      |      |      |                 |    |   |    |    |    |    |                 |                         |   |      |      |      |     |                          |   |      |      |      |                |                           |   |      |      |      |     |                            |   |      |      |     |
| ITEM            | SYMBOL   | CONDITION  | MIN.    | TYP.    | MAX.          | UNIT                    |      |               |               |                         |          |    |      |  |      |    |                 |    |   |        |        |        |     |                |      |   |        |        |       |     |      |        |           |      |      |      |      |                 |    |   |    |    |    |    |                 |                         |   |      |      |      |     |                          |   |      |      |      |                |                           |   |      |      |      |     |                            |   |      |      |     |
| Vsync Frequency | fV   | -  | 52      | 60      | 68            | Hz                      |      |               |               |                         |          |    |      |  |      |    |                 |    |   |        |        |        |     |                |      |   |        |        |       |     |      |        |           |      |      |      |      |                 |    |   |    |    |    |    |                 |                         |   |      |      |      |     |                          |   |      |      |      |                |                           |   |      |      |      |     |                            |   |      |      |     |
| Hsync Frequency | fH for VGA display mode                        | -  | 25.3    | 29.5    | 36.1          | kHz                     |      |               |               |                         |          |    |      |  |      |    |                 |    |   |        |        |        |     |                |      |   |        |        |       |     |      |        |           |      |      |      |      |                 |    |   |    |    |    |    |                 |                         |   |      |      |      |     |                          |   |      |      |      |                |                           |   |      |      |      |     |                            |   |      |      |     |
|                 | fH for QVGA display mode                       | -  | 13.1    | 15.2    | 17.7          |                         |      |               |               |                         |          |    |      |  |      |    |                 |    |   |        |        |        |     |                |      |   |        |        |       |     |      |        |           |      |      |      |      |                 |    |   |    |    |    |    |                 |                         |   |      |      |      |     |                          |   |      |      |      |                |                           |   |      |      |      |     |                            |   |      |      |     |
| DCLK Frequency  | fCLK for VGA display mode                      | -  | 17.2    | 20.9    | 26.7          | MHz                     |      |               |               |                         |          |    |      |  |      |    |                 |    |   |        |        |        |     |                |      |   |        |        |       |     |      |        |           |      |      |      |      |                 |    |   |    |    |    |    |                 |                         |   |      |      |      |     |                          |   |      |      |      |                |                           |   |      |      |      |     |                            |   |      |      |     |
|                 | fCLK for QVGA display mode                     | -  | 4.85    | 5.85    | 7.0           |                         |      |               |               |                         |          |    |      |  |      |    |                 |    |   |        |        |        |     |                |      |   |        |        |       |     |      |        |           |      |      |      |      |                 |    |   |    |    |    |    |                 |                         |   |      |      |      |     |                          |   |      |      |      |                |                           |   |      |      |      |     |                            |   |      |      |     |
|                 | 7B64PS 2708-<br>TX14D12VM1CBA-4<br>Page 8-3/6  | <b>8.2.2 INTERFACE TIMING FOR VGA DISPLAY MODE</b><br>Added : New page 8-3/6 for VGA display mode.   |         |         |               |                         |      |               |               |                         |          |    |      |  |      |    |                 |    |   |        |        |        |     |                |      |   |        |        |       |     |      |        |           |      |      |      |      |                 |    |   |    |    |    |    |                 |                         |   |      |      |      |     |                          |   |      |      |      |                |                           |   |      |      |      |     |                            |   |      |      |     |
|                 | 7B64PS 2708-<br>TX14D12VM1CBA-4<br>Page 8-6/6  | <b>8.5 INTERNAL PIN CONNECTION</b><br>Revised :<br><table border="1" style="width: 100%; border-collapse: collapse; margin-bottom: 5px;"> <thead> <tr> <th style="width: 15%;">PIN No.</th> <th style="width: 20%;">SIGNAL</th> <th>FUNCTION</th> </tr> </thead> <tbody> <tr> <td style="text-align: center;">10</td> <td style="text-align: center;">NC</td> <td>No Connection</td> </tr> </tbody> </table> <table border="1" style="width: 100%; border-collapse: collapse;"> <thead> <tr> <th style="width: 15%;">PIN No.</th> <th style="width: 20%;">SIGNAL</th> <th>FUNCTION</th> </tr> </thead> <tbody> <tr> <td style="text-align: center;">10</td> <td style="text-align: center;">V/Q</td> <td>Selection Signal for VGA or QVGA<br/>("H" = VGA , "L" or "NC" = QVGA)</td> </tr> </tbody> </table>  | PIN No. | SIGNAL  | FUNCTION      | 10                      | NC   | No Connection | PIN No.       | SIGNAL                  | FUNCTION | 10 | V/Q  | Selection Signal for VGA or QVGA<br>("H" = VGA , "L" or "NC" = QVGA) |      |    |                 |    |   |        |        |        |     |                |      |   |        |        |       |     |      |        |           |      |      |      |      |                 |    |   |    |    |    |    |                 |                         |   |      |      |      |     |                          |   |      |      |      |                |                           |   |      |      |      |     |                            |   |      |      |     |
| PIN No.         | SIGNAL   | FUNCTION   |         |         |               |                         |      |               |               |                         |          |    |      |  |      |    |                 |    |   |        |        |        |     |                |      |   |        |        |       |     |      |        |           |      |      |      |      |                 |    |   |    |    |    |    |                 |                         |   |      |      |      |     |                          |   |      |      |      |                |                           |   |      |      |      |     |                            |   |      |      |     |
| 10              | NC   | No Connection  |         |         |               |                         |      |               |               |                         |          |    |      |  |      |    |                 |    |   |        |        |        |     |                |      |   |        |        |       |     |      |        |           |      |      |      |      |                 |    |   |    |    |    |    |                 |                         |   |      |      |      |     |                          |   |      |      |      |                |                           |   |      |      |      |     |                            |   |      |      |     |
| PIN No.         | SIGNAL   | FUNCTION   |         |         |               |                         |      |               |               |                         |          |    |      |  |      |    |                 |    |   |        |        |        |     |                |      |   |        |        |       |     |      |        |           |      |      |      |      |                 |    |   |    |    |    |    |                 |                         |   |      |      |      |     |                          |   |      |      |      |                |                           |   |      |      |      |     |                            |   |      |      |     |
| 10              | V/Q  | Selection Signal for VGA or QVGA<br>("H" = VGA , "L" or "NC" = QVGA)   |         |         |               |                         |      |               |               |                         |          |    |      |  |      |    |                 |    |   |        |        |        |     |                |      |   |        |        |       |     |      |        |           |      |      |      |      |                 |    |   |    |    |    |    |                 |                         |   |      |      |      |     |                          |   |      |      |      |                |                           |   |      |      |      |     |                            |   |      |      |     |
|                 | 7B64PS 2712-<br>TX14D12VM1CBA-4<br>Page 12-1/1 | <b>12. DESIGNATION OF LOT MARK</b><br>Added : 12.4 Revision(Rev.) Control  |         |         |               |                         |      |               |               |                         |          |    |      |  |      |    |                 |    |   |        |        |        |     |                |      |   |        |        |       |     |      |        |           |      |      |      |      |                 |    |   |    |    |    |    |                 |                         |   |      |      |      |     |                          |   |      |      |      |                |                           |   |      |      |      |     |                            |   |      |      |     |

## RECORD OF REVISION

| DATE       | SHEET No.                                      | SUMMARY   |
|------------|--|---|
| May.13,'08 | 7B64PS 2708-<br>TX14D12VM1CBA-5<br>PAGE 8-6/6  | 8.5 INTERNAL PIN CONNECTION<br>Changed :<br>CN1 JAE : FA5B040HF1R3000(Sn plating) → FA5B040HP1R3000(Au plating)   |
|            | 7B64PS 2709-<br>TX14D12VM1CBA-5<br>PAGE 9-1/1  | 9. DIMENSIONAL OUTLINE<br>The lot label size and position is changed.   |
|            | 7B64PS 2712-<br>TX14D12VM1CBA-5<br>PAGE 12-1/1 | 12.1 LOT MARK<br>Changed : 5 digits for production number<br>↓<br>6 digits for production number<br>12.3 LOCATION OF LOT MARK<br>Changed :<br><div style="text-align: center;"> </div><br>12.4 REVISION(Rev.) CONTROL<br>Added : Rev. C CN1 JAE : FA5B040HP1R3000 |

### 3.GENERAL DATA

The specifications are applied to the following TFT-LCD Module with Back-light unit.  
Note : Inverter device for Back-light is not built in this Module.

|                             |  |
|-----------------------------|--|
| (1) Part Name               | TX14D12VM1CBA  |
| (2) Module Dimensions       | 131.0(W)mm x 102.2(H)mm x 10.9(D)mm typ.             |
| (3) LCD Active Area         | 115.2(W)mm x 86.4(H)mm                               |
| (4) Dot Pitch               | 0.12(W)mm x 3(R,G,B)(W) x 0.36(H)mm                  |
| (5) Resolution              | 320x3(R,G,B))(W)x240(H) dots                         |
| (6) Color Pixel Arrangement | R,G,B Vertical stripe                                |
| (7) LCD Type                | Transmissive Color TFT LCD (Normally White)          |
| (8) Display Type            | Active Matrix  |
| (9) Number of Colors        | 262k Colors (R,G,B 6bit digital each)                |
| (10) Backlight              | Cold Cathode Fluorescent Tube (L shaped CFL) x 1     |
| (11) Weight                 | (160)g (typ.)  |
| (12) Interface              | 40pin (C-MOS)  |
| (13) Power Supply Voltage   | 3.3V only (Include Timing Controller and Power Unit) |
| (14) Viewing Direction      | 6 O'clock (The direction it's hard to be discolored) |

#### 4. ABSOLUTE MAXIMUM RATINGS

##### 4.1 ELECTRICAL ABSOLUTE MAXIMUM RATINGS OF LCD

VSS=0V

| ITEM                   | SYMBOL | MIN. | MAX.    | UNIT | COMMENT    |
|------------------------|--------|------|---------|------|------------|
| Power Supply for Logic | VDD    | -0.3 | 4.0     | V    |            |
| Input Voltage          | VI     | -0.3 | VDD+0.3 |      | (Note 1)   |
| Input Current          | Ii     | 0    | 1       | A    |            |
| Static Electricity     | VESD0  | -    | ±100    | V    | (Note 2,3) |
|                        | VESD1  | -    | ±8      | kV   | (Note 2,4) |

Note 1 : DTMG,DCLK,RD0~RD5,GD0~GD5,BD0~BD5.

Note 2 : 200pF-250Ω 25°C - 70%RH

Note 3 : Interface Pin Connector.

Note 4 : The surface of metal bezel and LCD panel .

##### 4.2 ENVIRONMENTAL ABSOLUTE MAXIMUM RATINGS

| I T E M       | OPERATING                       |                               | STORAGE        |  | COMMENT                    |
|---------------|---------------------------------|-------------------------------|----------------|--|----------------------------|
|               | MIN.                            | MAX.                          | MIN.           | MAX.                                     |                            |
| Temperature   | (-20)                           | (70)                          | (-30)          | (80)                                     | (Note 2,3,6,7,8,10,12)     |
| Humidity      | (Note 1)                        |                               | (Note 1)       |  | Without condensation       |
| Vibration     | -                               | 4.9m/s <sup>2</sup><br>(0.5G) | -              | 19.6m/s <sup>2</sup><br>(2G)<br>(Note 5) | (Note 4)                   |
| Shock         | -                               | 29.4m/s <sup>2</sup><br>(3G)  | -              | 490m/s <sup>2</sup><br>(50G)<br>(Note 5) | XYZ directions<br>(Note 9) |
| Corrosive Gas | Not Acceptable                  |                               | Not Acceptable |  |                            |
| CFL Life Time | 50,000 h<br>(Average) (Note 11) |                               | -              |  | At 25°C , IL=5.0mA max.    |

Note 1 : Ta ≤ 40°C :85%RH max.

Ta > 40°C :Absolute humidity must be lower than the humidity of 85%RH at 40°C.

Note 2 : For storage condition Ta at -30°C < 48h , at 80°C < 100h.

For operating condition Ta at -20°C < 100h

Note 3 : Background color changes slightly depending on ambient temperature.

This phenomenon is reversible.

Note 4 : 5Hz~100Hz(Except resonance frequency)

Note 5 : This LCM will resume normal operation after finishing the test.

Note 6 : The response time will be slower at low temperature.

Note 7 : Only operation is guaranteed at operating temperature. Contrast, response time, another display quality are evaluated at +25°C.

Note 8 : When LCM is operated over 60°C ambient temperature , the ICFL of LCM should be adjusted to 3mA max.

Note 9 : Pulse Width : 10ms

Note 10 : This is panel surface temperature , not ambient temperature.

Note 11 : When brightness reached 50% of initial brightness.

Note 12 : When LCM be operated less than 0°C , the life time of CFL will be reduced .

The rise time of CFL ON will be longer when the ambient temperature below 0°C and confirming the characteristics of inverter is necessary .

### 4.3 BACK-LIGHT UNIT

| Item         | Symbol | Min. | Max. | UNIT   | COMMENT  |
|--------------|--------|------|------|--------|----------|
| Lamp Current | IL     | -    | 7.0  | m Arms | (Note 1) |
| Lamp Voltage | VL     | -    | 3000 | Vrms   | (Note 2) |

Note 1 : Please put your meter at GND cable to measurement.

Note 2 : Apply to the connector of the back light unit.

## 5. ELECTRICAL CHARACTERISTICS

### 5.1 ELECTRICAL CHARACTERISTICS OF LCD

Ta=25°C, VSS=0V

| ITEM                                | SYMBOL                     | CONDITION    | MIN. | TYP. | MAX. | UNIT |
|-------------------------------------|----------------------------|--------------|------|------|------|------|
| Power Supply Voltage                | VDD                        | -            | 3.0  | 3.3  | 3.6  | V    |
| Input Voltage for Logic<br>(Note 1) | VI                         | "H" level    | 2.0  | -    | VDD  | V    |
|                                     |                            | "L" level    | VSS  | -    | 0.8  |      |
| Power Supply Current<br>(Note 2)    | IDD                        | VDD-VSS=3.3V | -    | (65) | -    | mA   |
| Vsync Frequency                     | fV                         | -            | 52   | 60   | 68   | Hz   |
| Hsync Frequency                     | fH for VGA display mode    | -            | 25.3 | 29.5 | 36.1 | kHz  |
|                                     | fH for QVGA display mode   | -            | 13.1 | 15.2 | 17.7 |      |
| DCLK Frequency                      | fCLK for VGA display mode  | -            | 17.2 | 20.9 | 26.7 | MHz  |
|                                     | fCLK for QVGA display mode | -            | 4.85 | 5.85 | 7.0  |      |

Note 1 : DTMG, DCLK, RD0~RD5, GD0~GD5, BD0~BD5.

Note 2 : fV=60Hz, Ta=25°C, Pattern used as display pattern : All Black.

Note 3 : Need to make sure of flickering and rippling of display when setting the frame frequency in your set.

### 5.2 ELECTRICAL CHARACTERISTICS OF BACKLIGHT

| ITEM                           | SYMBOL         | MIN.   | TYP.  | MAX.  | UNIT | NOTE    |
|--------------------------------|----------------|--------|-------|-------|------|---------|
| Lamp Voltage                   | VL             | -      | (760) | -     | Vrms | Ta=25°C |
| Frequency                      | fL             | -      | (55)  | -     | kHz  |         |
| Lamp Current (1Lamp)(Note 6,7) | IL             | (2.0)  | (5.0) | (6.0) | mA   | Ta=25°C |
| Starting Discharge Voltage     | VS<br>(Note 2) | (1300) | -     | -     | Vrms | Ta=5°C  |

Note 1 : Please design your lamp driving circuit (inverter) according to the above specifications, and inform HITACHI about it.

Note 2 : Starting discharge voltage is increased when LCM is operating under low temperature.

Please check the characteristics of your inverter before applying to your set.

Note 3 : Average life time of CFL will be decreased when LCM is operating under low temperature.

Note 4 : Under lower driving frequency of an inverter, a certain Backlight system (CFL & CFL reflection sheet) may generate a sound noise. Before designing the inverter, please consider the driving frequency and noise.

Note 5 : When IL is over 6.0mA, it may cause uneven contrast near CFL location, due to heat dispersion from CFL.

Note 6 : We recommend to equip protection circuit (To stop output) which works under abnormal operation to the inverter for CFL.

Note 7 : Measurement of IL is provided for GND side of CFL.



## 6. OPTICAL CHARACTERISTICS

### 6.1 OPTICAL CHARACTERISTICS OF LCD

Ta=25°C (Backlight on)

| ITEM                          | SYMBOL     | CONDITION                      | MIN.                           | TYP. | MAX. | UNIT | NOTE |
|-------------------------------|------------|--------------------------------|--------------------------------|------|------|------|------|
| Viewing Area                  | $\theta_x$ | $\phi=0^\circ, K \geq 10.0$    | -                              | 65   | -    | deg  | 1~5  |
|                               | $\theta_x$ | $\phi=180^\circ, K \geq 10.0$  | -                              | 65   | -    | deg  | 1~5  |
|                               | $\theta_y$ | $\phi=90^\circ, K \geq 10.0$   | -                              | 70   | -    | deg  | 1~5  |
|                               | $\theta_y$ | $\phi=270^\circ, K \geq 10.0$  | -                              | 50   | -    | deg  | 1~5  |
| Contrast Ratio                | K          | $\phi=0^\circ, \theta=0^\circ$ | 120                            | 350  | -    | -    | 5    |
| Response Time (rise+fall)     | tr+tf      | $\phi=0^\circ, \theta=0^\circ$ | -                              | (45) | -    | ms   | 6    |
| Color Tone<br>(Primary Color) | Red        | x                              | $\phi=0^\circ, \theta=0^\circ$ | 0.56 | 0.61 | 0.66 | -    |
|                               |            | y                              |                                | 0.28 | 0.33 | 0.38 | -    |
|                               | Green      | x                              |                                | 0.25 | 0.30 | 0.35 | -    |
|                               |            | y                              |                                | 0.52 | 0.57 | 0.62 | -    |
|                               | Blue       | x                              |                                | 0.09 | 0.14 | 0.19 | -    |
|                               |            | y                              |                                | 0.03 | 0.08 | 0.13 | -    |
|                               | White      | x                              |                                | 0.24 | 0.29 | 0.34 | -    |
|                               |            | y                              |                                | 0.24 | 0.29 | 0.34 | -    |

Note 1 : Driving Condition  
 Display Pattern : White Raster  
 ICFL Current : (5.0)mA

(Measurement condition : HITACHI standard)  
 (Note 3~6) : See next page.

Note 2 : Measurement Condition  
 (Transmittance)

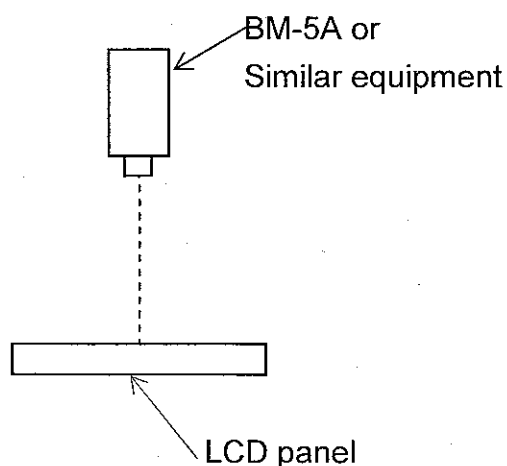

Note 3 : Definition of  $\theta$  and  $\phi$   
(Normal)  
Viewing direction

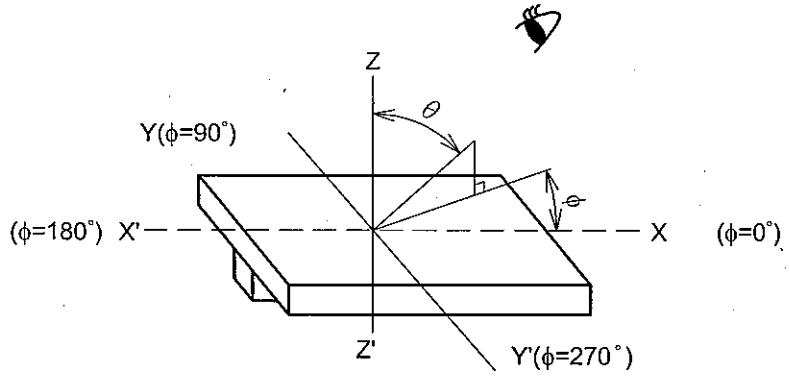

Note 4 : Definition of Viewing angle  $\phi_1$  and  $\phi_2$

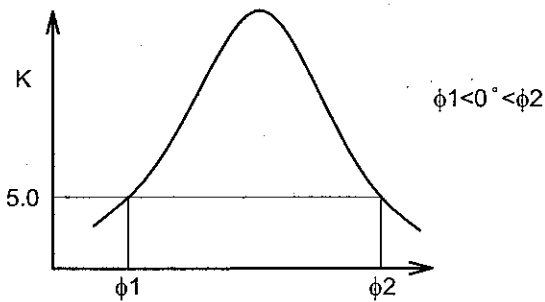

Contrast ratio "K" vs Viewing angle " $\phi$ "

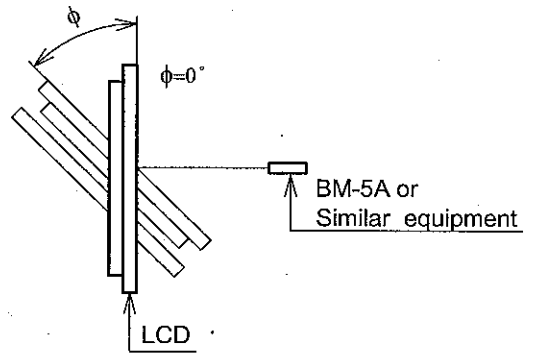

Note 5 : Definition of contrast "K"

$$K = \frac{\text{White Brightness}}{\text{Black Brightness}}$$

Note 6 : Definition optical response time

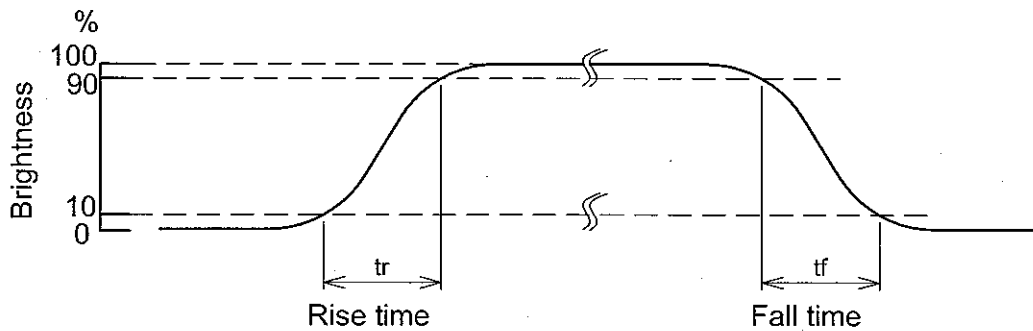
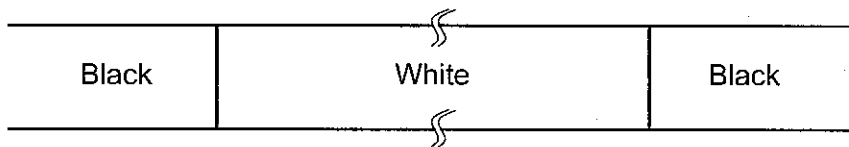

## 6.2 OPTICAL CHARACTERISTICS OF BACKLIGHT

| ITEM                  | MIN. | TYP. | MAX. | UNIT              | NOTE                          |
|-----------------------|------|------|------|-------------------|-------------------------------|
| Brightness            | 200  | 350  | -    | cd/m <sup>2</sup> | IL=(5.0)mA (Note 1)           |
| Rise Time             | -    | 3    | -    | Minute            | IL=(5.0)mA<br>Brightness 80%  |
| Brightness Uniformity | -    | -    | ±25  | %                 | Under mentioned<br>(Note 1,3) |

(Measurement condition : HITACHI standard)

CFL: 0h operation, Ta=25°C

Display data should be set to all "ON".

Note 1 : Measurement after 10 minutes from CFL operating.

Active area center.

Note 2 : Brightness control : 100%.

Note 3 : Measurement of the following 9 places on the display.

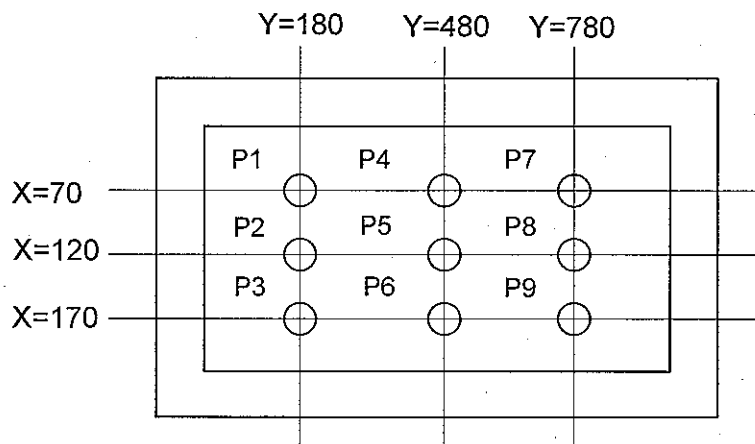

Note 4 : Definition of the brightness tolerance.

$$\left( \frac{\text{Max. brightness or Min. brightness} - \text{Average brightness}}{\text{Average brightness}} \right) \times 100$$

# 7.BLOCK DIAGRAM

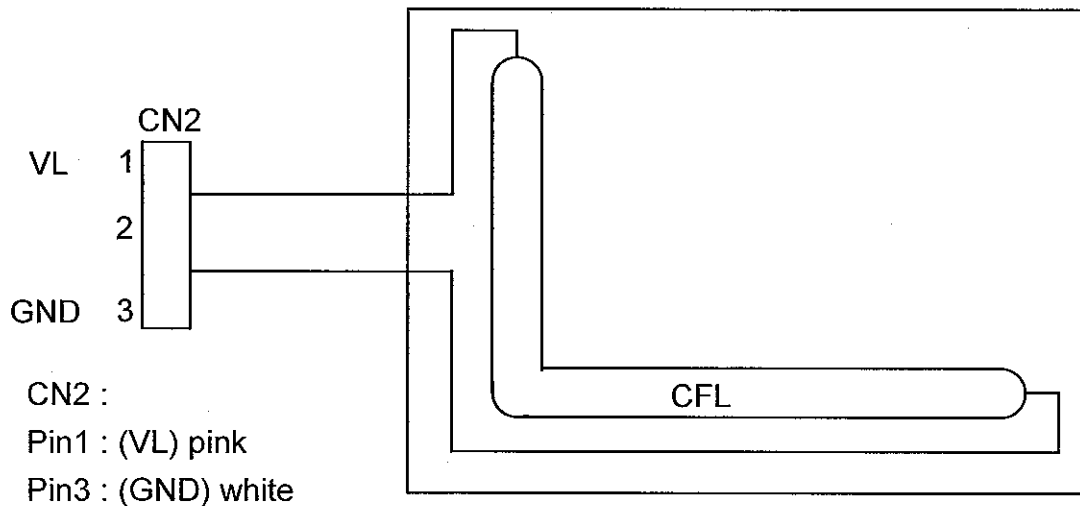
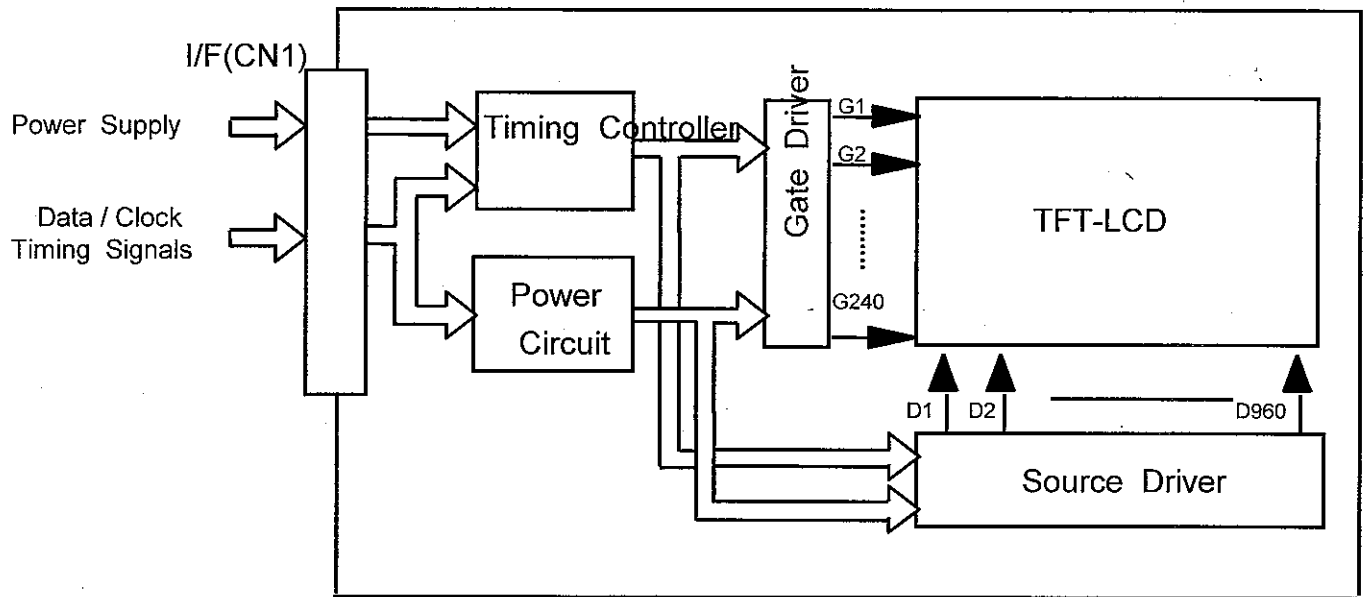

# 8.INTERFACE TIMING

## 8.1 Timing Chart

(Data is latched negative edge trigger of DCLK)

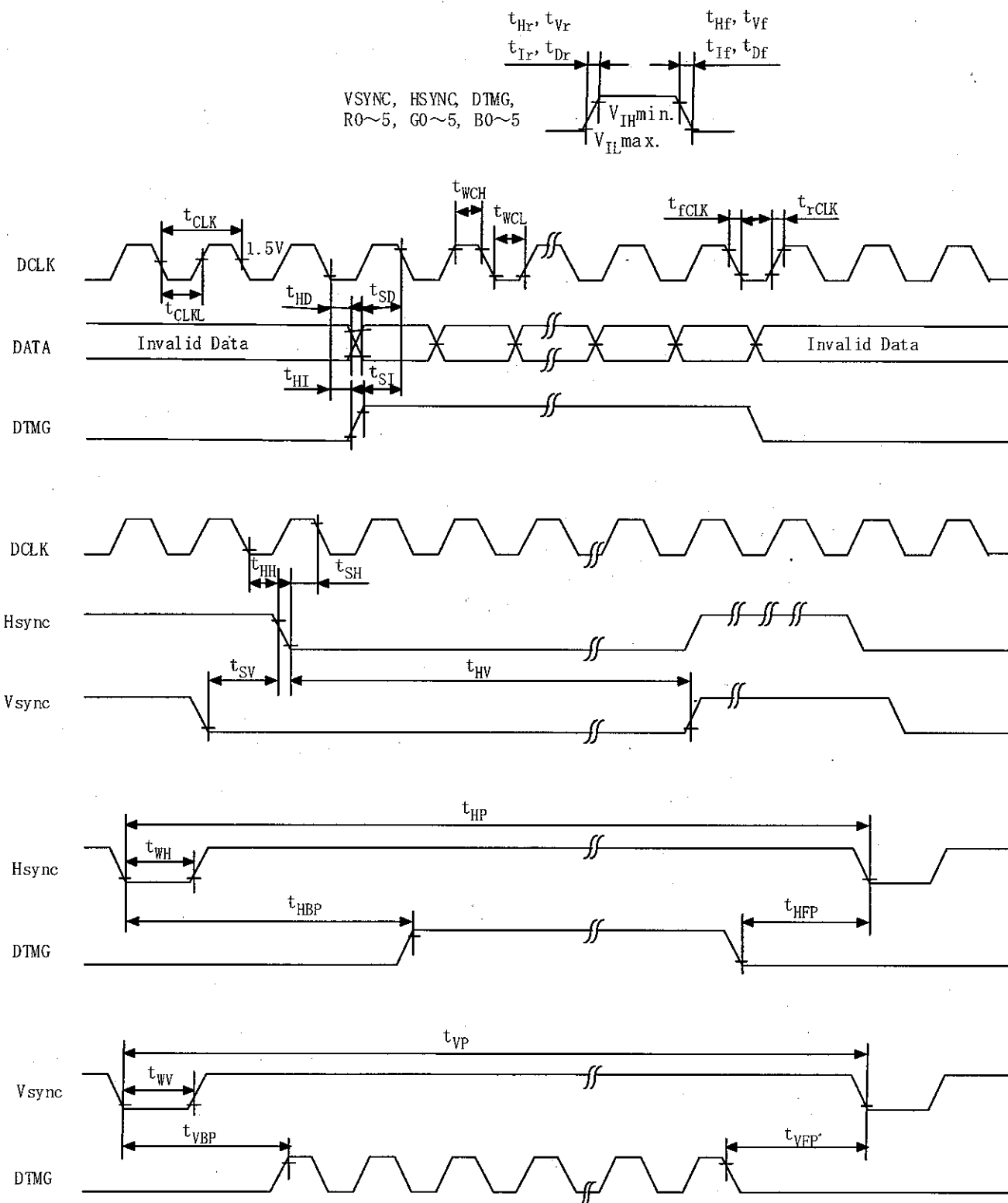

Note 1 : DTMG is definition of the above timing for Hsync and Vsync.

Note 2 : No matter when Hsync and Vsync is inputted ,this LCM can be drove only DTMG Signal. DTMG should be set to low level when it is not input valid data.

### 8.2.1 INTERFACE TIMING FOR QVGA DISPLAY MODE

| ITEM  |                        | SYMBOL           | MIN. | TYP.  | MAX.  | UNIT | REMARKS                  |
|-------|------------------------|------------------|------|-------|-------|------|--------------------------|
| DCLK  | Cycle time             | $t_{CLK}$        | (60) | (171) | (206) | ns   |                          |
|       | Low level Width        | $t_{WCL}$        | 12   | -     | -     |      |                          |
|       | High level Width       | $t_{WCH}$        | 12   | -     | -     |      |                          |
|       | Rise time              | $t_{rCLK}$       | -    | -     | (20)  |      |                          |
|       | Fall time              | $t_{fCLK}$       | -    | -     | (20)  |      |                          |
|       | Duty                   | D                | 0.45 | 0.5   | 0.55  | -    | $D = t_{CLKL} / t_{CLK}$ |
| Hsync | Set up time            | $t_{SH}$         | 5    | -     | -     | ns   | for DCLK                 |
|       | Hold time              | $t_{HH}$         | 10   | -     | -     |      |                          |
|       | Cycle                  | $t_{HP}$         | 358  | (385) | 453   | tCLK |                          |
|       | Valid width            | $t_{WH}$         | 4    | (5)   | -     |      |                          |
|       | Rise/Fall time         | $t_{Hr}, t_{Hf}$ | -    | -     | 30    | ns   |                          |
| Vsync | Set up                 | $t_{SV}$         | 0    | -     | -     | tCLK | for Hsync                |
|       | Hold                   | $t_{HV}$         | 2    | -     | -     |      |                          |
|       | Cycle                  | $t_{VP}$         | 247  | (253) | 535   | tHP  |                          |
|       | Valid width            | $t_{WV}$         | 2    | (2)   | -     |      |                          |
|       | Rise/Fall time         | $t_{Vr}, t_{Vf}$ | -    | -     | 50    | ns   |                          |
| DTMG  | Set up time            | $t_{SI}$         | 5    | -     | -     | ns   | for DCLK                 |
|       | Hold time              | $t_{HI}$         | 10   | -     | -     |      |                          |
|       | Rise/Fall time         | $t_{Ir}, t_{If}$ | -    | -     | 30    | ns   |                          |
|       | Horizontal back porch  | $t_{HBP}$        | 24   | (35)  | 99    |      |                          |
|       | Horizontal front porch | $t_{HFP}$        | 8    | (30)  | 62    | tCLK |                          |
|       | Vertical back porch    | $t_{VBP}$        | 7    | (9)   | 197   | tHP  |                          |
|       | Vertical front porch   | $t_{VFP}$        | 2    | (4)   | 97    |      |                          |
| Data  | Set up time            | $t_{SD}$         | 5    | -     | -     | ns   | for DCLK                 |
|       | Hold time              | $t_{HD}$         | 10   | -     | -     |      |                          |
|       | Rise/Fall time         | $t_{Dr}, t_{Df}$ | -    | -     | 20    | ns   |                          |

Note : Vsync Cycle should be set to odd.

## 8.2.2 INTERFACE TIMING FOR VGA DISPLAY MODE

| ITEM  |                        | SYMBOL           | MIN. | TYP.   | MAX. | UNIT | REMARKS   |
|-------|------------------------|------------------|------|--------|------|------|-----------|
| DCLK  | Cycle time             | $t_{CLK}$        | 37.4 | (47.8) | 58.1 | ns   |           |
|       | Low level Width        | $t_{WCL}$        | 15   | -      | -    |      |           |
|       | High level Width       | $t_{WCH}$        | 15   | -      | -    |      |           |
|       | Rise time              | $t_{rCLK}$       | -    | -      | 25   |      |           |
|       | Fall time              | $t_{fCLK}$       | -    | -      | 25   |      |           |
|       | Duty                   | D                | 0.45 | 0.5    | 0.55 |      |           |
| Hsync | Set up time            | $t_{SH}$         | 5    | -      | -    | ns   | for DCLK  |
|       | Hold time              | $t_{HH}$         | 10   | -      | -    |      |           |
|       | Cycle                  | $t_{HP}$         | 679  | (709)  | 739  | tCLK |           |
|       | Valid width            | $t_{WH}$         | 4    | 5      | 5    |      |           |
|       | Rise/Fall time         | $t_{Hr}, t_{Hf}$ | -    | -      | 30   | ns   |           |
| Vsync | Set up                 | $t_{SV}$         | 0    | -      | -    | tCLK | for Hsync |
|       | Hold                   | $t_{HV}$         | 2    | -      | -    |      |           |
|       | Cycle                  | $t_{VP}$         | 485  | (491)  | 533  | tHP  |           |
|       | Valid width            | $t_{WV}$         | 2    | 2      | 2    |      |           |
|       | Rise/Fall time         | $t_{Vr}, t_{Vf}$ | -    | -      | 50   | ns   |           |
| DTMG  | Set up time            | $t_{SI}$         | 5    | -      | -    | ns   | for DCLK  |
|       | Hold time              | $t_{HI}$         | 10   | -      | -    |      |           |
|       | Rise/Fall time         | $t_{Ir}, t_{If}$ | -    | -      | 30   | ns   |           |
|       | Horizontal back porch  | $t_{HBP}$        | 24   | (37)   | 50   |      |           |
|       | Horizontal front porch | $t_{HFP}$        | 15   | (32)   | 49   | tCLK |           |
|       | Vertical back porch    | $t_{VBP}$        | 4    | (7)    | 28   |      |           |
|       | Vertical front porch   | $t_{VFP}$        | 1    | (4)    | 25   | tHP  |           |
| Data  | Set up time            | $t_{SD}$         | 5    | -      | -    | ns   | for DCLK  |
|       | Hold time              | $t_{HD}$         | 10   | -      | -    |      |           |
|       | Rise/Fall time         | $t_{Dr}, t_{Df}$ | -    | -      | 25   | ns   |           |

Note : Vsync Cycle should be set to odd.

### 8.3 POWER ON/OFF SEQUENCE

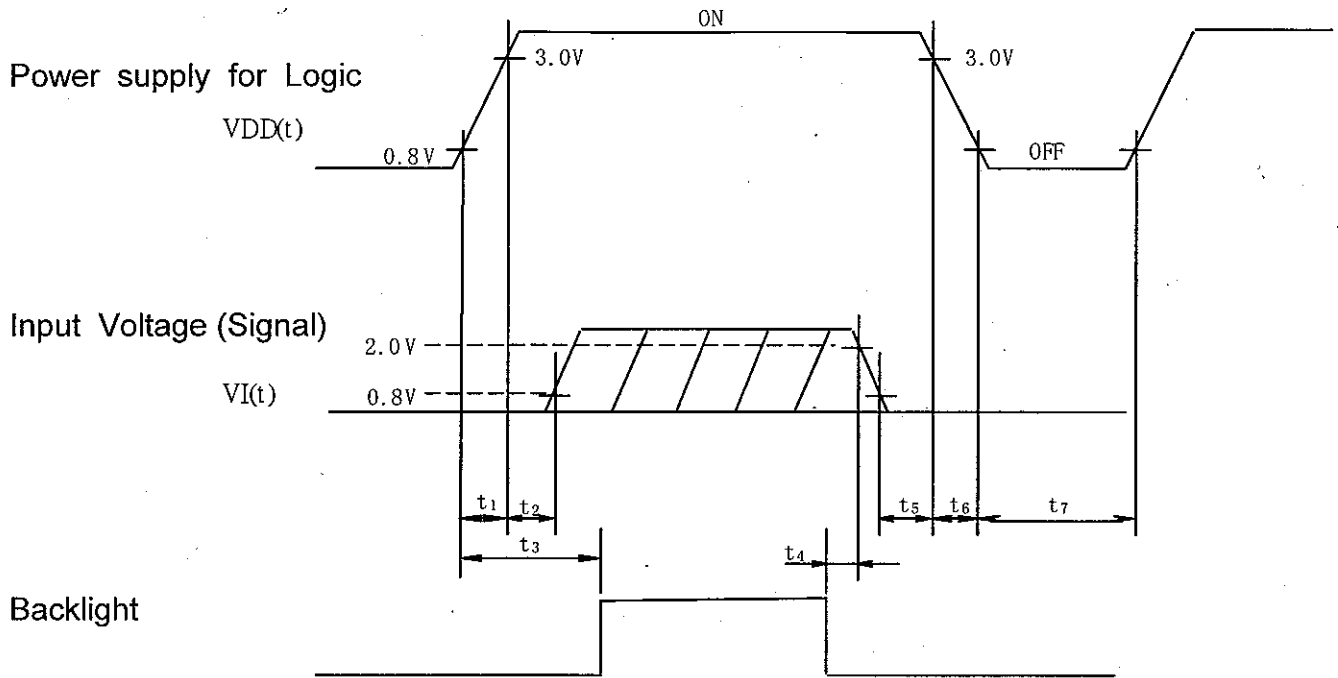

POWER ON

- $t_1 \leq 15\text{ms}$
- $0\text{ms} < t_2 \leq 45\text{ms}$
- $0.1\text{s} \leq t_3$

POWER OFF

- $5\text{ms} \leq t_4$
- $0\text{ms} \leq t_5 \leq 45\text{ms}$
- $0\text{ms} \leq t_6 \leq 20\text{ms}$
- $0.4\text{s} \leq t_7$

Note 1 :  $0\text{V} \leq VI(t) \leq VDD(t)$

VI(t) and VDD(t) is a surfeit of condition for power on/off.

Note 2 : Input Voltage(Signal) should not be set high impedance when power on.



### 8.4 RELATIONSHIP BETWEEN DISPLAYED COLOR AND INPUT DATA

|             | COLOR & GRAY SCALE | DATA SIGNAL |    |    |    |    |    |    |    |    |    |    |    |    |    |    |    |    |    |
|-------------|--------------------|-------------|----|----|----|----|----|----|----|----|----|----|----|----|----|----|----|----|----|
|             |                    | R5          | R4 | R3 | R2 | R1 | R0 | G5 | G4 | G3 | G2 | G1 | G0 | B5 | B4 | B3 | B2 | B1 | B0 |
| Basic Color | Black              | 0           | 0  | 0  | 0  | 0  | 0  | 0  | 0  | 0  | 0  | 0  | 0  | 0  | 0  | 0  | 0  | 0  | 0  |
|             | Red(0)             | 1           | 1  | 1  | 1  | 1  | 1  | 0  | 0  | 0  | 0  | 0  | 0  | 0  | 0  | 0  | 0  | 0  | 0  |
|             | Green(0)           | 0           | 0  | 0  | 0  | 0  | 0  | 1  | 1  | 1  | 1  | 1  | 1  | 0  | 0  | 0  | 0  | 0  | 0  |
|             | Blue(0)            | 0           | 0  | 0  | 0  | 0  | 0  | 0  | 0  | 0  | 0  | 0  | 0  | 1  | 1  | 1  | 1  | 1  | 1  |
|             | Cyan               | 0           | 0  | 0  | 0  | 0  | 0  | 1  | 1  | 1  | 1  | 1  | 1  | 1  | 1  | 1  | 1  | 1  | 1  |
|             | Magenta            | 1           | 1  | 1  | 1  | 1  | 1  | 0  | 0  | 0  | 0  | 0  | 0  | 1  | 1  | 1  | 1  | 1  | 1  |
|             | Yellow             | 1           | 1  | 1  | 1  | 1  | 1  | 1  | 1  | 1  | 1  | 1  | 1  | 0  | 0  | 0  | 0  | 0  | 0  |
|             | White              | 1           | 1  | 1  | 1  | 1  | 1  | 1  | 1  | 1  | 1  | 1  | 1  | 1  | 1  | 1  | 1  | 1  | 1  |
| Red         | Black              | 0           | 0  | 0  | 0  | 0  | 0  | 0  | 0  | 0  | 0  | 0  | 0  | 0  | 0  | 0  | 0  | 0  |    |
|             | Red(62)            | 0           | 0  | 0  | 0  | 0  | 1  | 0  | 0  | 0  | 0  | 0  | 0  | 0  | 0  | 0  | 0  | 0  |    |
|             | Red(61)            | 0           | 0  | 0  | 0  | 1  | 0  | 0  | 0  | 0  | 0  | 0  | 0  | 0  | 0  | 0  | 0  | 0  |    |
|             | :                  | :           | :  | :  | :  | :  | :  | :  | :  | :  | :  | :  | :  | :  | :  | :  | :  | :  |    |
|             | :                  | :           | :  | :  | :  | :  | :  | :  | :  | :  | :  | :  | :  | :  | :  | :  | :  | :  |    |
|             | Red(1)             | 1           | 1  | 1  | 1  | 1  | 0  | 0  | 0  | 0  | 0  | 0  | 0  | 0  | 0  | 0  | 0  | 0  |    |
|             | Red(0)             | 1           | 1  | 1  | 1  | 1  | 1  | 0  | 0  | 0  | 0  | 0  | 0  | 0  | 0  | 0  | 0  | 0  |    |
| Green       | Black              | 0           | 0  | 0  | 0  | 0  | 0  | 0  | 0  | 0  | 0  | 0  | 0  | 0  | 0  | 0  | 0  | 0  |    |
|             | Green(62)          | 0           | 0  | 0  | 0  | 0  | 0  | 0  | 0  | 0  | 0  | 0  | 1  | 0  | 0  | 0  | 0  | 0  |    |
|             | Green(61)          | 0           | 0  | 0  | 0  | 0  | 0  | 0  | 0  | 0  | 0  | 1  | 0  | 0  | 0  | 0  | 0  | 0  |    |
|             | :                  | :           | :  | :  | :  | :  | :  | :  | :  | :  | :  | :  | :  | :  | :  | :  | :  | :  |    |
|             | :                  | :           | :  | :  | :  | :  | :  | :  | :  | :  | :  | :  | :  | :  | :  | :  | :  | :  |    |
|             | Green(1)           | 0           | 0  | 0  | 0  | 0  | 0  | 1  | 1  | 1  | 1  | 1  | 0  | 0  | 0  | 0  | 0  | 0  |    |
|             | Green(0)           | 0           | 0  | 0  | 0  | 0  | 0  | 1  | 1  | 1  | 1  | 1  | 1  | 0  | 0  | 0  | 0  | 0  |    |
| Blue        | Black              | 0           | 0  | 0  | 0  | 0  | 0  | 0  | 0  | 0  | 0  | 0  | 0  | 0  | 0  | 0  | 0  | 0  |    |
|             | Blue(62)           | 0           | 0  | 0  | 0  | 0  | 0  | 0  | 0  | 0  | 0  | 0  | 0  | 0  | 0  | 0  | 0  | 1  |    |
|             | Blue(61)           | 0           | 0  | 0  | 0  | 0  | 0  | 0  | 0  | 0  | 0  | 0  | 0  | 0  | 0  | 0  | 1  | 0  |    |
|             | :                  | :           | :  | :  | :  | :  | :  | :  | :  | :  | :  | :  | :  | :  | :  | :  | :  | :  |    |
|             | :                  | :           | :  | :  | :  | :  | :  | :  | :  | :  | :  | :  | :  | :  | :  | :  | :  | :  |    |
|             | Blue(1)            | 0           | 0  | 0  | 0  | 0  | 0  | 0  | 0  | 0  | 0  | 0  | 0  | 1  | 1  | 1  | 1  | 0  |    |
|             | Blue(0)            | 0           | 0  | 0  | 0  | 0  | 0  | 0  | 0  | 0  | 0  | 0  | 0  | 1  | 1  | 1  | 1  | 1  |    |

### 8.5 INTERNAL PIN CONNECTION

CN1 JAE : FA5B040HP1R3000(Au plating) (Suitable FPC : t0.3±0.03mm , 0.5±0.03mm pitch)

| PIN No. | SIGNAL | FUNCTION   |
|---------|--------|--|
| 1       | VDD    | Power Supply for Logic   |
| 2       | VDD    |  |
| 3       | VDD    |  |
| 4       | VDD    |  |
| 5       | NC     | No Connection  |
| 6       | DTMG   | Timing Signal for Data   |
| 7       | VSS    | GND  |
| 8       | DCLK   | Dot Clock  |
| 9       | VSS    | GND  |
| 10      | V/Q    | Selection signal for VGA or QVGA<br>("H"=VGA , "L" or "NC" = QVGA) |
| 11      | VSS    | GND  |
| 12      | B5     | Blue Data  |
| 13      | B4     |  |
| 14      | B3     |  |
| 15      | VSS    | GND  |
| 16      | B2     | Blue Data  |
| 17      | B1     |  |
| 18      | B0     |  |
| 19      | VSS    | GND  |
| 20      | G5     | Green Data   |
| 21      | G4     |  |
| 22      | G3     |  |
| 23      | VSS    | GND  |
| 24      | G2     | Green Data   |
| 25      | G1     |  |
| 26      | G0     |  |
| 27      | VSS    | GND  |
| 28      | R5     | Red Data   |
| 29      | R4     |  |
| 30      | R3     |  |
| 31      | VSS    | GND  |
| 32      | R2     | Red Data   |
| 33      | R1     |  |
| 34      | R0     |  |
| 35      | TEST   | (Note 1)   |
| 36      | VSS    | GND  |
| 37      | NC     | No Connection  |
| 38      | NC     |  |
| 39      | NC     |  |
| 40      | NC     |  |

Note 1 : Keep open electrically , HITACHI test only.

CN2 JST Housing : BHR-03VS-1

| PIN No. | SIGNAL | LEVEL | FUNCTION             |
|---------|--------|-------|----------------------|
| 1       | VL     | -     | Power Supply for CFL |
| 2       | NC     | -     | No connection        |
| 3       | GND    | -     | GND for CFL(OV)      |

# 9. DIMENSIONAL OUTLINE

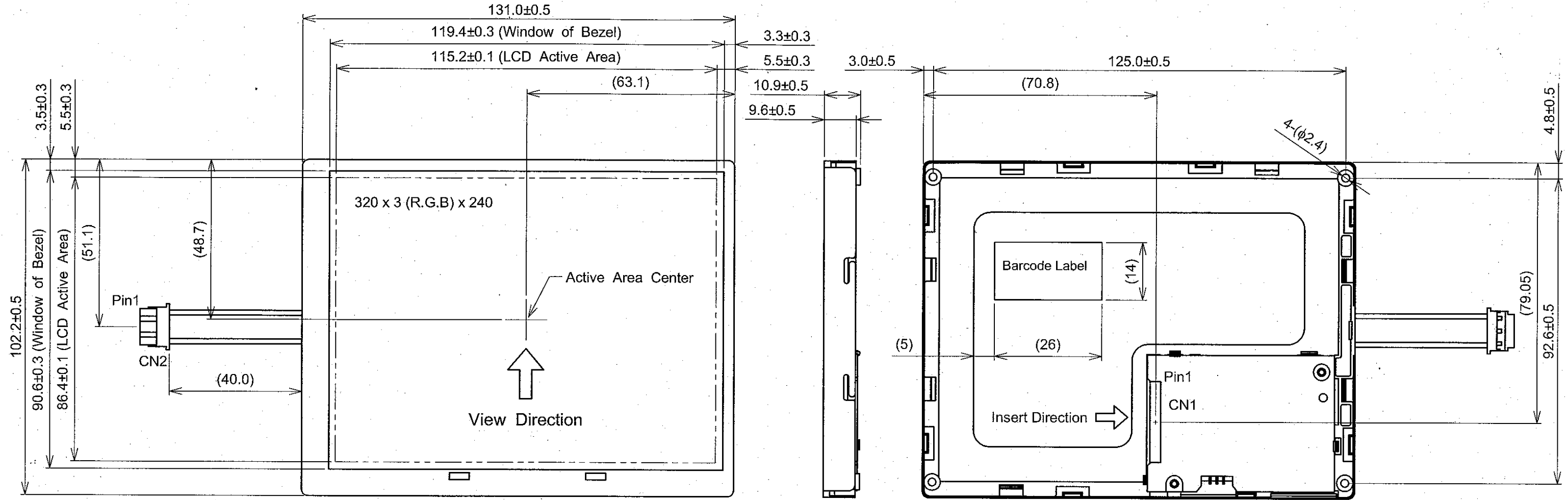

Recommended design rule for CN1 FPC

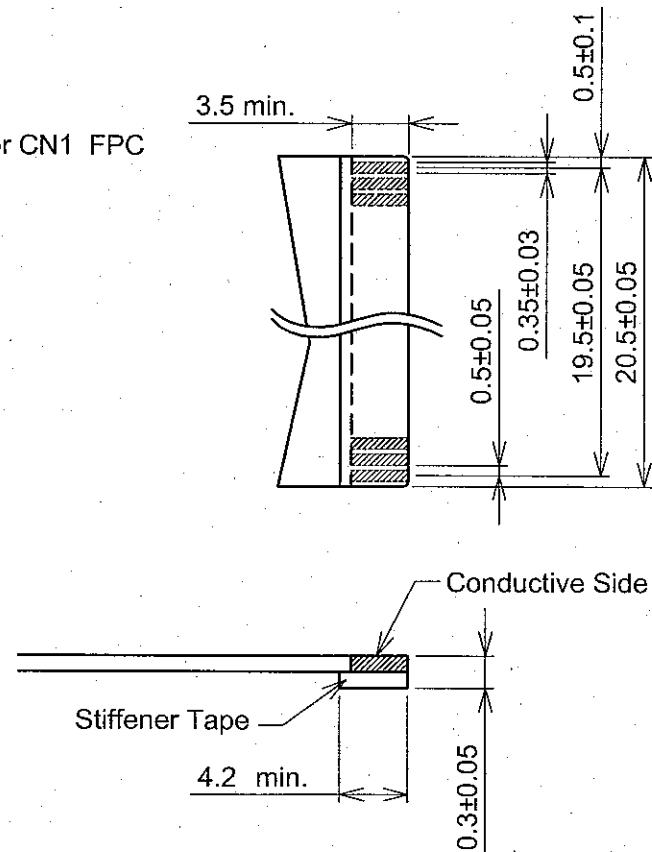

Scale : NTS  
Unit : mm

## 10. APPEARANCE STANDARD

### 10.1 APPEARANCE INSPECTION CONDITION

Visual inspection should be done under the following condition.

- (1) The inspection should be done in a dark room.  
(about 1000(lx),500(lx)min. and non-directive)
- (2) The distance between eyes of an inspector and the LCD module is 30cm.
- (3) The viewing zone is shown the figure.

The  $\theta$  is defined as  $\theta \leq 45^\circ$  for LCM power off

$\theta \leq 5^\circ$  for LCM power on

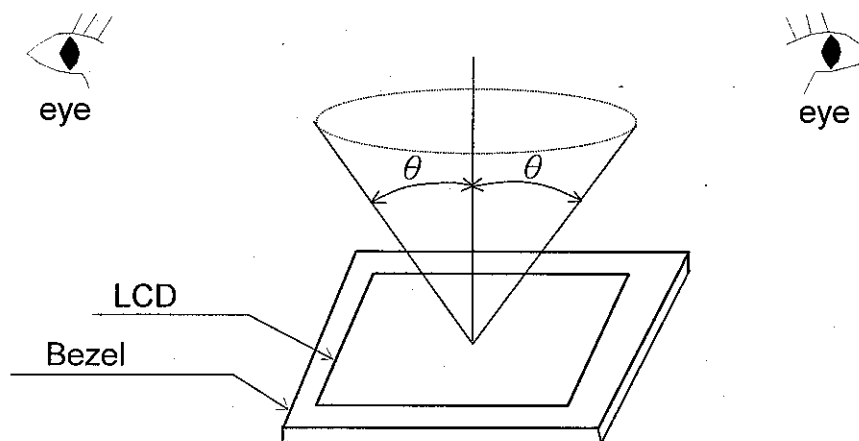

### 10.2 DEFINITION OF ZONE

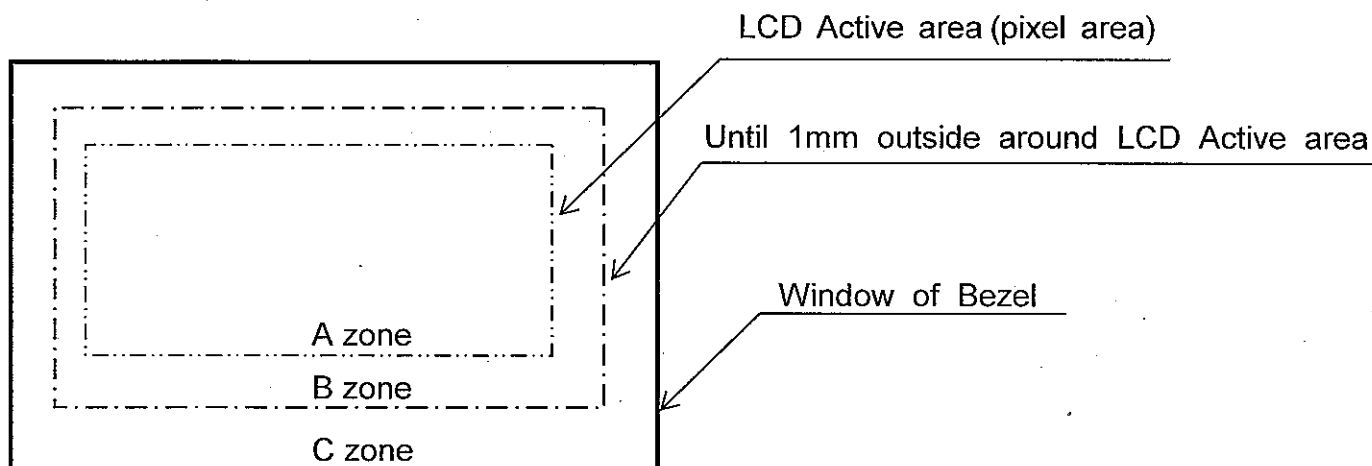

### 10.3 APPEARANCE SPECIFICATION

#### (1)LCD Appearance

\*) If the problem related to this section occurs about this item, the responsible persons of both party (Customer and HITACHI) will discuss the matter in detail.

| No.                | ITEM                           | CRITERIA                              |   |                              |               | APPLIED ZONE |     |
|--------------------|--------------------------------|---------------------------------------|---|------------------------------|---------------|--------------|-----|
|                    |                                | Length<br>L(mm)                       | Width<br>W(mm)  | Maximum number<br>acceptable | Minimum space |              |     |
| L<br>C<br>D        | Scratches                      | Ignored                               | $W \leq 0.02$   | Ignored                      | -             | A,B          |     |
|                    |                                | $L \leq 40$                           | $0.02 < W \leq 0.04$  | 10                           | -             |              |     |
|                    |                                | $L \leq 20$                           | $W \leq 0.04$   | 10                           | -             |              |     |
|                    |                                | Dent                                  |   |                              |               |              | A   |
|                    | Dent                           |                                       | Distinguished one is acceptable<br>(To be judged by HITACHI standard) |                              |               |              | A   |
|                    | Wrinkles in Polarizer          |                                       | Same as above   |                              |               |              | A   |
|                    | Bubbles                        | Average diameter<br>D(mm)             |   | Maximum number<br>acceptable |               | A            |     |
|                    |                                | $D \leq 0.2$                          |   | Ignored                      |               |              |     |
|                    |                                | $0.2 < D \leq 0.3$                    |   | 12                           |               |              |     |
|                    |                                | $0.3 < D \leq 0.5$                    |   | 3                            |               |              |     |
|                    | $0.5 < D$                      |                                       | none  |                              |               |              |     |
|                    | Stains<br>Foreign<br>Materials | Filamentous (Line shape)              |   |                              |               | A,B          |     |
|                    |                                | Length<br>L(mm)                       | Width<br>W(mm)  | Maximum number<br>acceptable |               |              |     |
|                    | Dark Spot                      | $L \leq 2.0$                          | $W \leq 0.03$   | Ignored                      |               |              |     |
|                    |                                | $L \leq 3.0$                          | $0.03 < W \leq 0.05$  | 6                            |               |              |     |
|                    |                                | $L \leq 2.5$                          | $0.05 < W \leq 0.1$   | 1                            |               |              |     |
|                    |                                |                                       | Round(Dot shape)  |                              |               |              | A,B |
|                    | Average diameter<br>D(mm)      |                                       | Maximum number<br>acceptable  |                              | Minimum Space |              |     |
|                    | $D < 0.2$                      |                                       | Ignored   |                              | -             |              |     |
|                    | $0.2 \leq D < 0.3$             |                                       | 10  |                              | 10 mm         |              |     |
| $0.3 \leq D < 0.4$ |                                | 5                                     |   | 30 mm                        |               |              |     |
| $0.4 \leq D$       |                                | none                                  |   | -                            |               |              |     |
| The total number   |                                | Filamentous + Round=10                |   |                              |               |              |     |
|                    |                                | Those wiped out easily are acceptable |   |                              |               |              |     |
| Color Tone         |                                | To be judged by HITACHI STANDARD      |   |                              |               | A            |     |
| Color Uniformity   |                                | Same as above                         |   |                              |               | A            |     |
| Dot Defect         |                                |                                       | Maximum number<br>acceptable  |                              | A             |              |     |
|                    | Sparkle mode                   | 1 dot                                 |   | 4                            |               |              |     |
|                    |                                | 2 dots (Note.(3)-(f))                 |   | 1                            |               |              |     |
|                    |                                | Total                                 |   | 5                            |               |              |     |
|                    | Black mode                     | 1 dot                                 |   | 5                            |               |              |     |
|                    |                                | 2 dots (Note.(3)-(f))                 |   | 2                            |               |              |     |
| Total              |                                | 5                                     |   |                              |               |              |     |
| Total              |                                | 10                                    |   |                              |               |              |     |

(2) CFL BACKLIGHT APPEARANCE

| No.                                       | ITEM                     | CRITERIA                  |                 |                           | APPLIED ZONE |
|---|--------------------------|---------------------------|-----------------|---------------------------|--------------|
| C<br>F<br>L                               | Dark Spots               | Average diameter<br>D(mm) |                 | Maximum number acceptable | A            |
|   | White Spots              | $D \leq 0.4$              |                 | ignored                   |              |
|   | Foreign Materials (Spot) | $0.4 < D$                 |                 | none                      |              |
| B<br>A<br>C<br>K<br>L<br>I<br>G<br>H<br>T | Foreign Materials (Line) | Width<br>W(mm)            | Length<br>L(mm) | Maximum number acceptable | A            |
|   |                          | $W \leq 0.2$              | $L \leq 2.5$    | 1                         |              |
|   |                          |                           | $2.5 < L$       | None                      |              |
|   | $0.2 < W$                | -                         | none            |                           |              |
| S<br>c<br>r<br>a<br>c<br>h<br>e<br>s      | Scratches                | Width<br>W(mm)            | Length<br>L(mm) | Maximum number acceptable | A            |
|   |                          | $W \leq 0.1$              | -               | ignored                   |              |
|   |                          | $0.1 < W \leq 0.2$        | $L \leq 11.0$   | 1                         |              |
|   |                          |                           | $11.0 < L$      | None                      |              |
|   |                          | $0.2 < W$                 | -               | none                      |              |

Note 1 : Definition of average diameter (D)

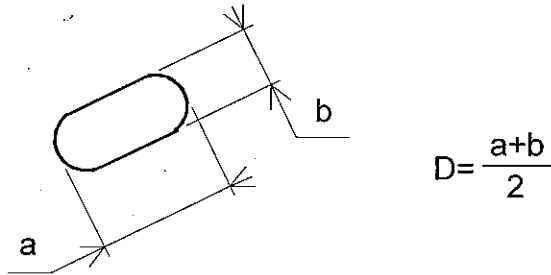

Note 2 : Definition of length (L) and width (W)

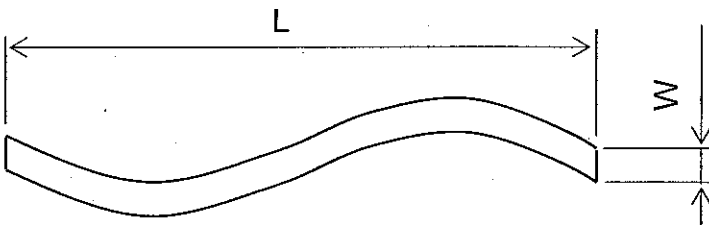

Note 3 : Definition of dot defect

- (a) Dot Defect : Defect Area  $> 1/2$  dot
- (b) Sparkle mode : Brightness of dot is more than 30% at Black raster.
- (c) Black mode : Brightness of dot is less than 70% at R.G.B raster.
- (d) 1 dot : Defect dot is isolated , not attached to other defect dot.
- (e) N dot : N defect dots are consecutive (fig.1).  
(N means the number of defect dots.)

( fig .1)

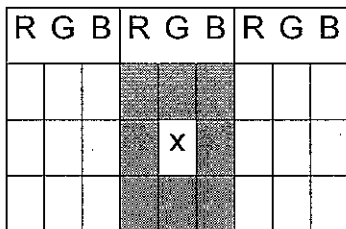

2 dots defect included defect dot "X" is defined as follows.

Adjacent dots to defect dot "X" : 

- (f) Counting definition of adjacent dots (1 set) : same as 1 dot defect.
- (g) Those wiped out easily are acceptable.

## 11. PRECAUTION IN DESIG

### 11.1 PRECAUTIONS AGAINST ELECTROSTATIC DISCHARGE

As this module contains C-MOS LSIs, it is not strong against electrostatic discharge. Make certain that the operator's body is connected to the ground through a wrist band, etc. And don't touch I/F pins directly.

### 11.2 HANDLING PRECAUTIONS

- (1) As the adhesives used for adhering upper/lower polarizer's and frame are made of organic substances which will be deteriorated by a chemical reaction with such chemicals as acetone, toluene, ethanol and isopropyl alcohol. The following are recommended for use:  
normal hexane  
Please contact with us when it is necessary for you to use chemicals other than the above.
- (2) Lightly wipe to clean the dirty surface with absorbent cotton or other soft material like chamois, soaked in the recommended chemicals without scrubbing it hardly. Always wipe the surface horizontally or vertically. Never give a wipe in a circle. To prevent the display surface from damage and keep the appearance in good state, it is sufficient, in general, to wipe it with absorbent cotton.
- (3) Immediately wipe off saliva or water drop attached on the display area because it may cause deformation or faded color.
- (4) Foggy dew deposited on the surface may cause a damage, stain or dirt to the polarizer.  
When you need to take out the LCD module from some place at low temperature for test, etc.  
It is required to be warmed them up to temperature higher than room temperature before taking them out.
- (5) Touching the display area or I/F pins with bare hands or contaminating them are prohibited, because the stain on the display area and poor insulation between terminals are often caused by being touched with bare hands.  
(Some cosmetics are detrimental to polarizer's.)
- (6) In general, the glass is fragile so that, especially on its periphery, tends to be cracked or chipped in handling. Please not give the LCD module sharp shocks by falling, etc.
- (7) Maximum pressure to the surface must be less than  $1.96 \times 10^4$  Pa.  
And if the pressure area is less than  $1\text{cm}^2$ , maximum pressure must be less than 1.96N.
- (8) Since the metal width is narrow on these locations (see page 9-1/1), please careful with handling.
- (9) Top sheets shall be cleaned gently using a soft cloth such as those used for glasses. Hard wiping accumulated dust will leave scars on the surface even using a cloth.



### 11.3 OPERATION PRECAUTION

- (1) Using a LCM module beyond its maximum ratings may result in its permanent destruction.

LCM module's should usually be used under recommended operating conditions shown in chapter 4. Exceeding any of these conditions may adversely affect its reliability.

- (2) Response time will be extremely delayed at lower temperature than the specified operating temperature range and on the other hand LCD's shows dark blue at higher temperature.

However those phenomena do not main defects of the LCD module. Those phenomena will disappear in the specified operating temperature range.

- (3) If the display area is pushed hard during operation, some display patterns will be abnormally display.

- (4) A slight dew depositing on terminals may cause electrochemical reaction which leads to terminal open circuit. Please operate the LCD module under the relative condition of 40°C 85%RH.

### 11.4 STORAGE

In case of storing LCD module for a long period of time (for instance, for years) for the purpose of replacement use, the following precautions necessary.

- (1) Store the LCD modules in a dark place; do not expose them to sunlight or ultraviolet rays.
- (2) Keep the temperature between 10°C and 35°C at normal humidity.
- (3) Store the LCD modules in the container which is used for shipping from us.
- (4) No articles shall be left on the surface over an extended period of time.

## 12. DESIGNATION OF LOT MARK

### 12.1 LOT MARK

Lot mark is consisted of 5 digits for production lot and 6 digits for production control.

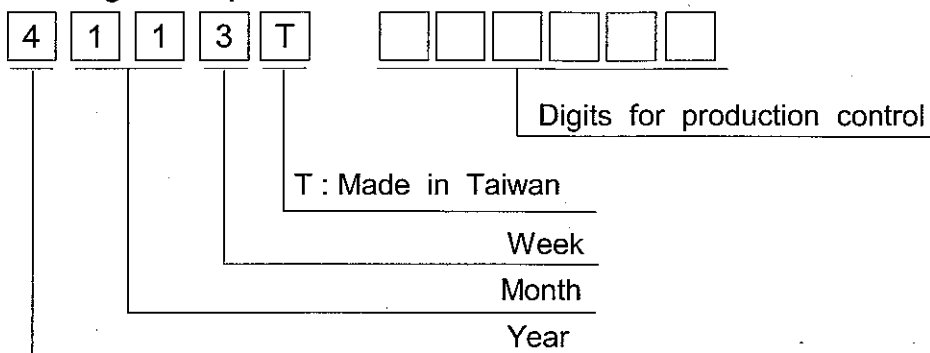

| Year | Figure in lot mark |
|------|--------------------|
| 2008 | 8                  |
| 2009 | 9                  |
| 2010 | 0                  |
| 2011 | 1                  |
| 2012 | 2                  |

| Month | Figure in lot mark | Month | Figure in lot mark |
|-------|--------------------|-------|--------------------|
| Jan.  | 01                 | Jul.  | 07                 |
| Feb.  | 02                 | Aug.  | 08                 |
| Mar.  | 03                 | Sep.  | 09                 |
| Apr.  | 04                 | Oct.  | 10                 |
| May   | 05                 | Nov.  | 11                 |
| Jun.  | 06                 | Dec.  | 12                 |

| Week (day in calendar) | Figure in lot mark |
|------------------------|--------------------|
| 1~7                    | 1                  |
| 8~14                   | 2                  |
| 15~21                  | 3                  |
| 22~28                  | 4                  |
| 29~31                  | 5                  |

### 12.2 SERIAL No.

Serial No. is consisted of 6 digits number (000001~999999).

### 12.3 LOCATION OF LOT MARK

Label is bring attached on the back side of module.

### 12.4 REVISION(Rev.) CONTROL

Rev. column is controlled by the manufacturing A-Z except I and 0 is to be written on this column

| Rev No. | ITEM   |
|---------|--|
| A       | PCB for QVGA Display Mode                                  |
| B       | PCB for QVGA&VGA Display Mode ( H : VGA ; L or NC : QVGA ) |
| C       | CN1 JAE : FA5B040HP1R3000                                  |



### 13. PRECAUTION FOR USE

(1) A limit sample should be provided by the both parties on an occasion when the both parties agree to its necessity.

Judgment by a limit sample shall take effect after the limit sample has been established and confirmed by the both parties.

(2) On the following occasions, the handling of the problem should be decided through discussion and agreement between responsible persons of the both parties.

(1) When a question is arisen in the specifications.

(2) When a new problem is arisen which is not specified in this specifications.

(3) When an inspection specifications change or operating condition change by customer is reported to HITACHI, and some problem is arisen in the specification due to the change.

(4) When a new problem is arisen at the customer's operating set for sample evaluation.

(3) Regarding the treatment for maintenance and repairing, both parties will discuss it in six months later after latest delivery of this product.

The precaution that should be observed when handling LCM have been explained above.

If any points are unclear or if you have any requests, please contact with HITACHI.