

LOC		DIST		REVISIONS			
GP	00	REV	DATE	BY	CHKD	APPD	
A		REVISED PER EC OS11-0009-05	08APR05	BM		MY	
A1		REVISED PER ECO-10-000444	04NOV09	KK		AEG	

- MATERIAL:
HOUSING AND EJECTOR:
HIGH TEMPERATURE NYLON
CONTACT:
PHOSPHOR BRONZE
 - FINISH:
CONTACT AREA:
0.000760[.00030] MIN GOLD OVER
0.001270[.00050] MIN THICK NICKEL
SOLDER TAIL:
0.00381[.000150] MIN THICK MATTE TIN OVER
0.000641[.00025] MIN THICK NICKEL
 - MODULE BOARD PADS:
FOR OPTIMUM PERFORMANCE PADS SHOULD BE SMOOTH AND FLAT
PADS TO BE PLATED WITH:
0.00102[.00040] MIN THICK GOLD OVER
0.00127[.00050] MIN THICK NICKEL
- 4 PN: 5390402-6 IS THE SAME CONNECTOR AS 5390402-3 WITH LUBRICANT ADDED TO THE CONTACTS.
- 5 OBSOLETE PARTS: OBSOLETE CIS STREAMLINING PER D.RENAUD/D.SINISI

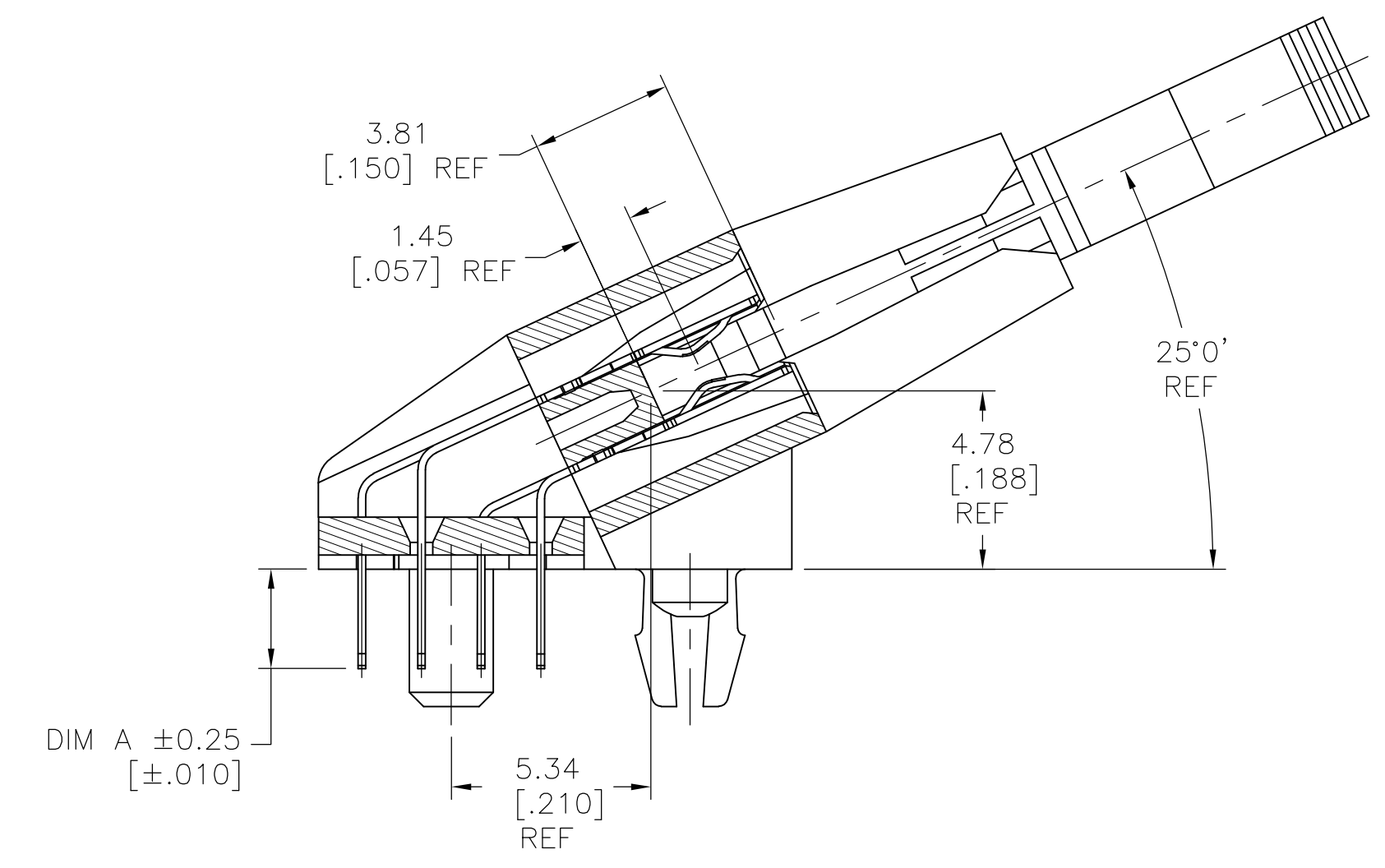
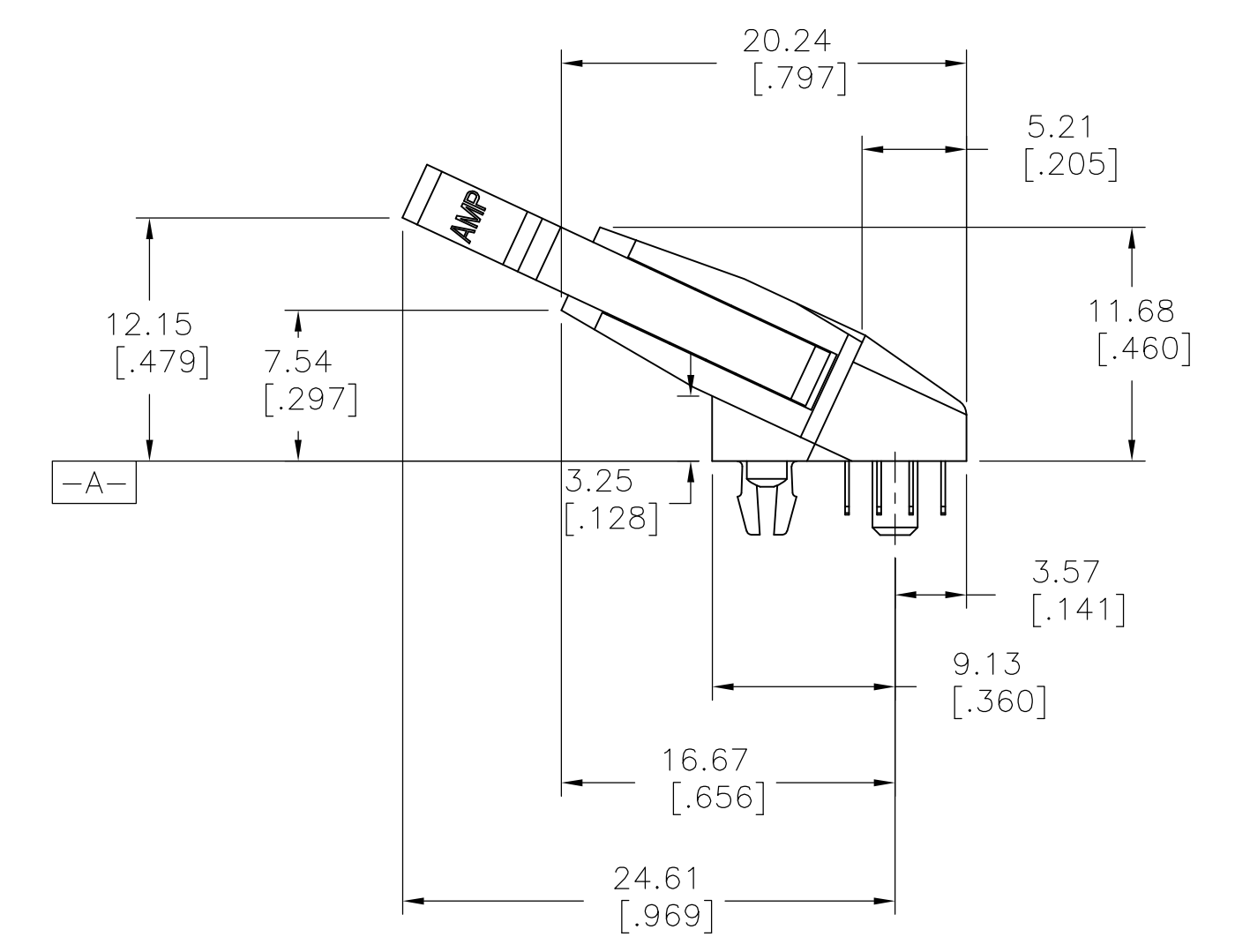
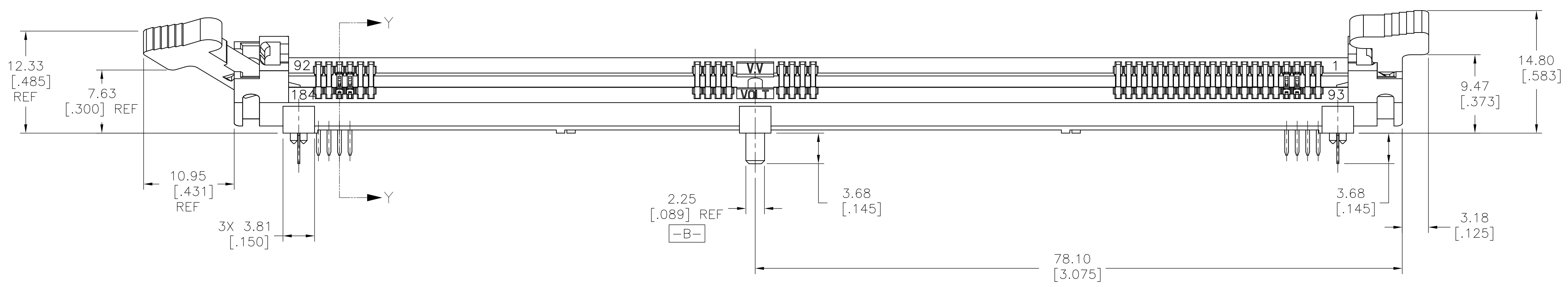
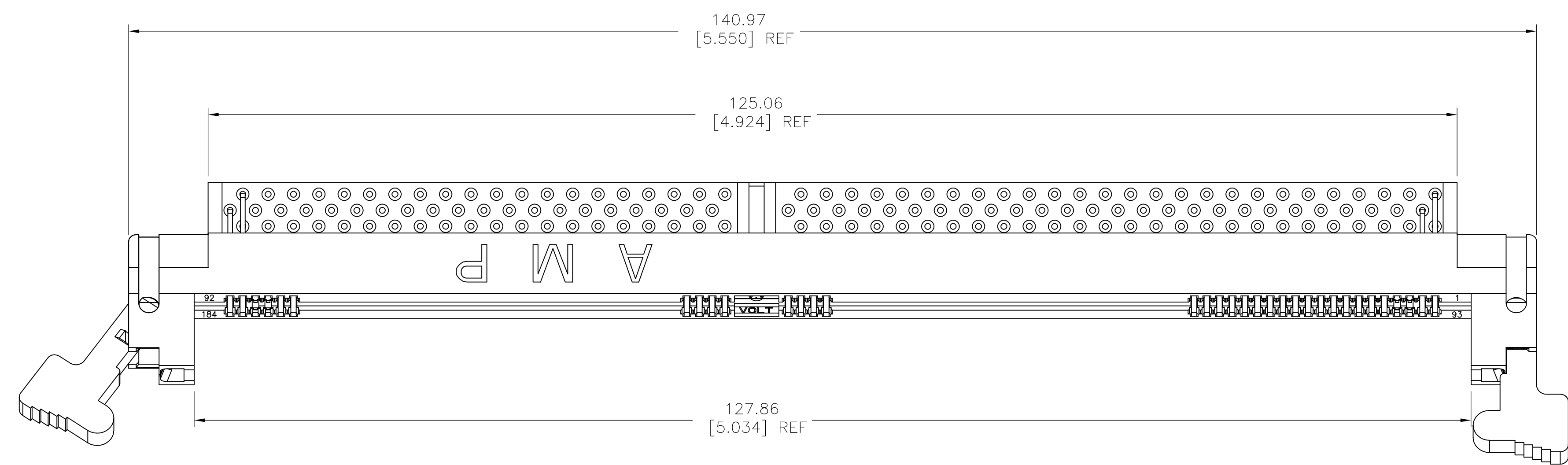

SECTION Y-Y
SCALE 6:1

DIM A	KEY POSITIONS	DESCRIPTION	PART NUMBER
4.50 [.177]	DETAIL B	184 POSN. DDR, 2.5V	5390402-7
3.18 [.125]	DETAIL B	184 POSN. DDR, 2.5V	5390402-6 4
3.18 [.125]	DETAIL A	184 POSN. DDR, 1.8V	5390402-4
3.18 [.125]	DETAIL B	184 POSN. DDR, 2.5V	5390402-3
2.62 [.103]	DETAIL A	184 POSN. DDR, 1.8V	5390402-2
2.62 [.103]	DETAIL B	184 POSN. DDR, 2.5V	5390402-1

THIS DRAWING IS A CONTROLLED DOCUMENT.		DIN S. WAITMAN 11OCT04		Tyco Electronics Corporation	
DIMENSIONS: mm		CHK: M. YFOMANS 11OCT04		Harrisburg, Pa 17105-3608	
TOLERANCES UNLESS OTHERWISE SPECIFIED:		APPD: M. YFOMANS 11OCT04		NAME: SOCKEY ASSEMBLY, 184 POS, DDR	
0 PLC ± -		PRODUCT SPEC		LOW PROFILE DIMM2P, LEAD FREE	
1 PLC ± -		APPLICATION SPEC		SIZE: A1	
2 PLC ± 0.13[.005]		WEIGHT: -		CAGE CODE: 00779	
3 PLC ± -		CUSTOMER DRAWING		DRAWING NO: 5390402	
4 PLC ± -		SCALE: 3:1		SHEET 1 OF 3	
ANGLES ± -		REV: A1			

LOC		DIST		REVISIONS				
GP	00	P	LTR	DESCRIPTION	DATE	DN	APVD	
				SEE SHEET 1				

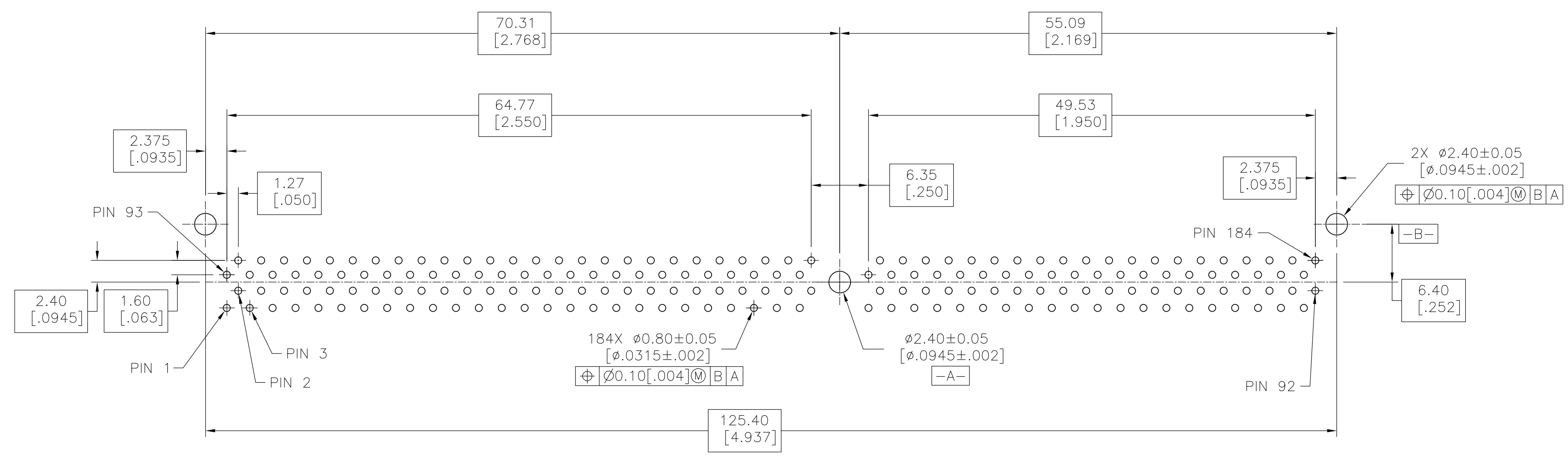

RECOMMENDED CIRCUIT BOARD HOLE LAYOUT

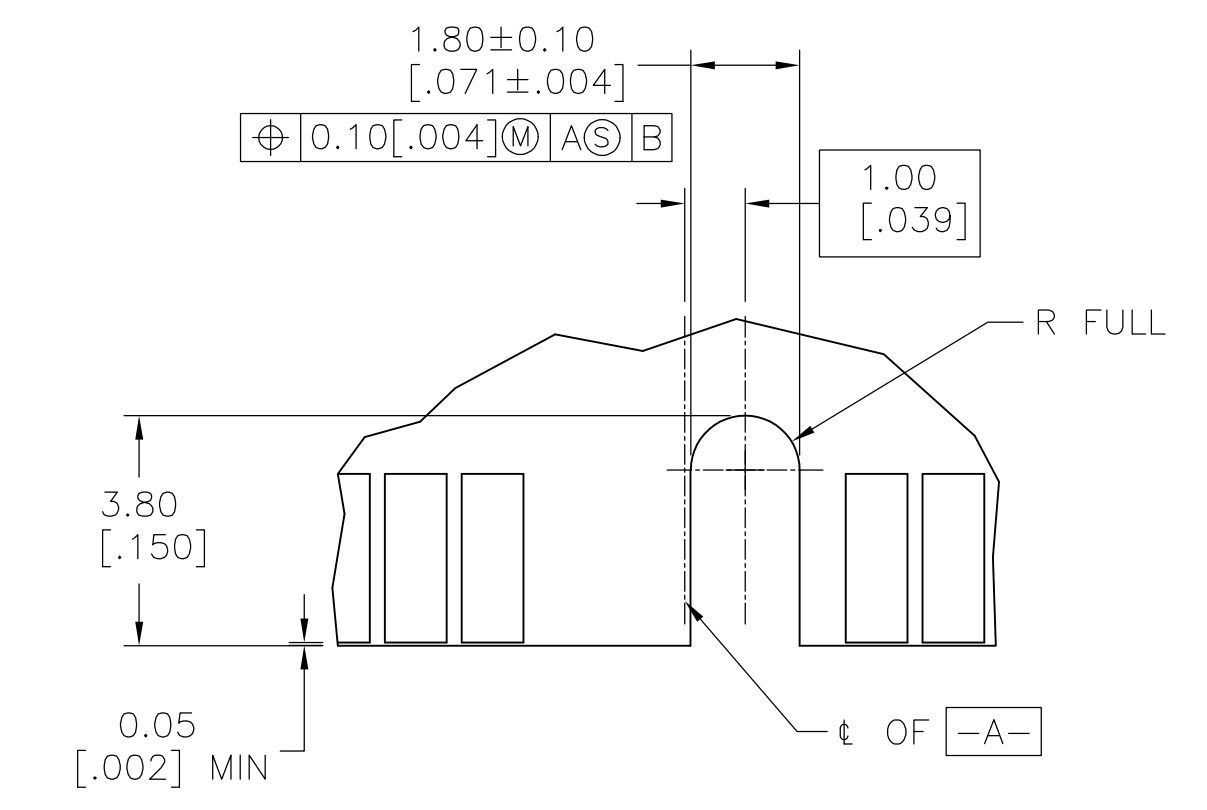
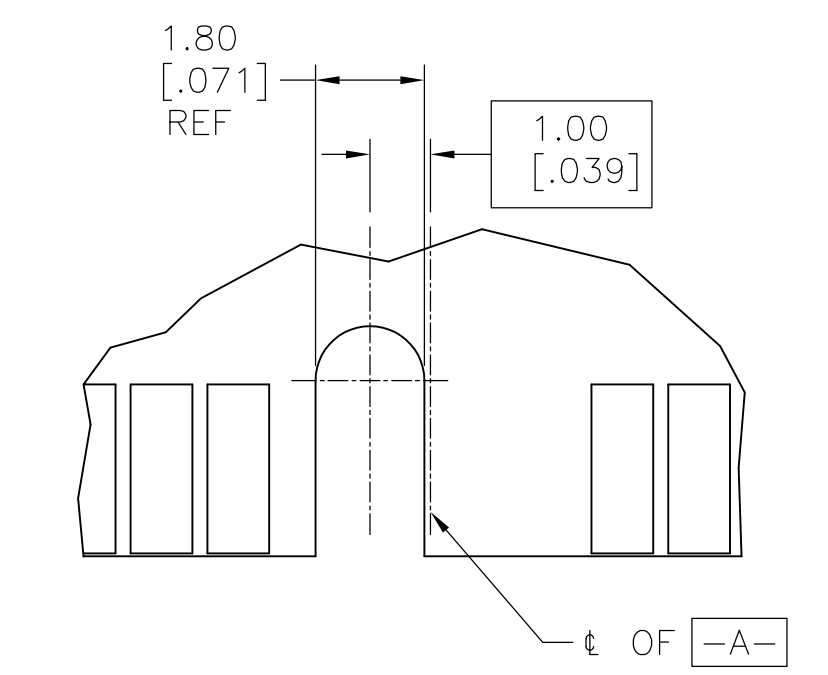
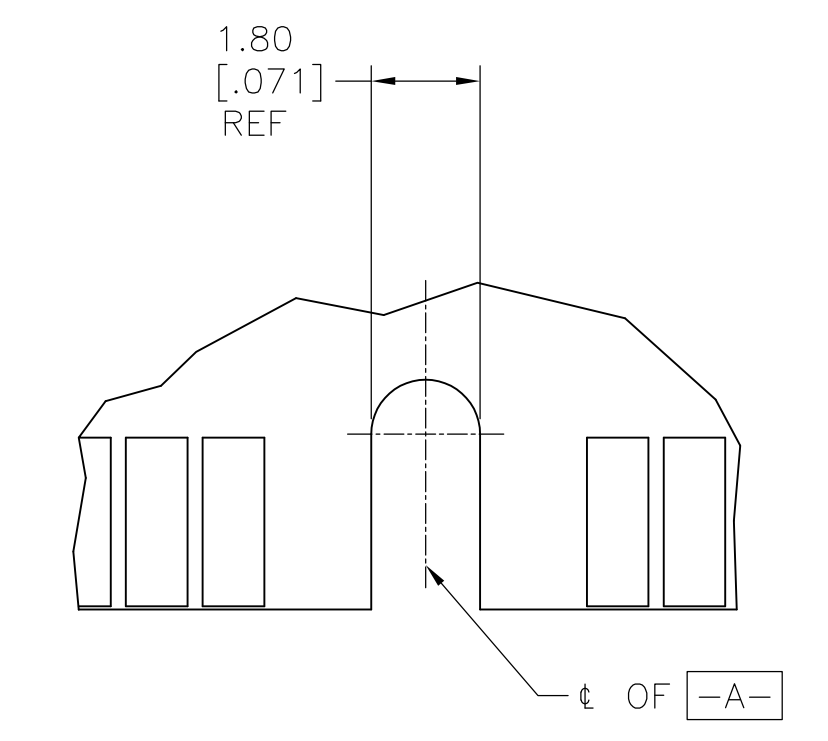

KEY POSITIONS

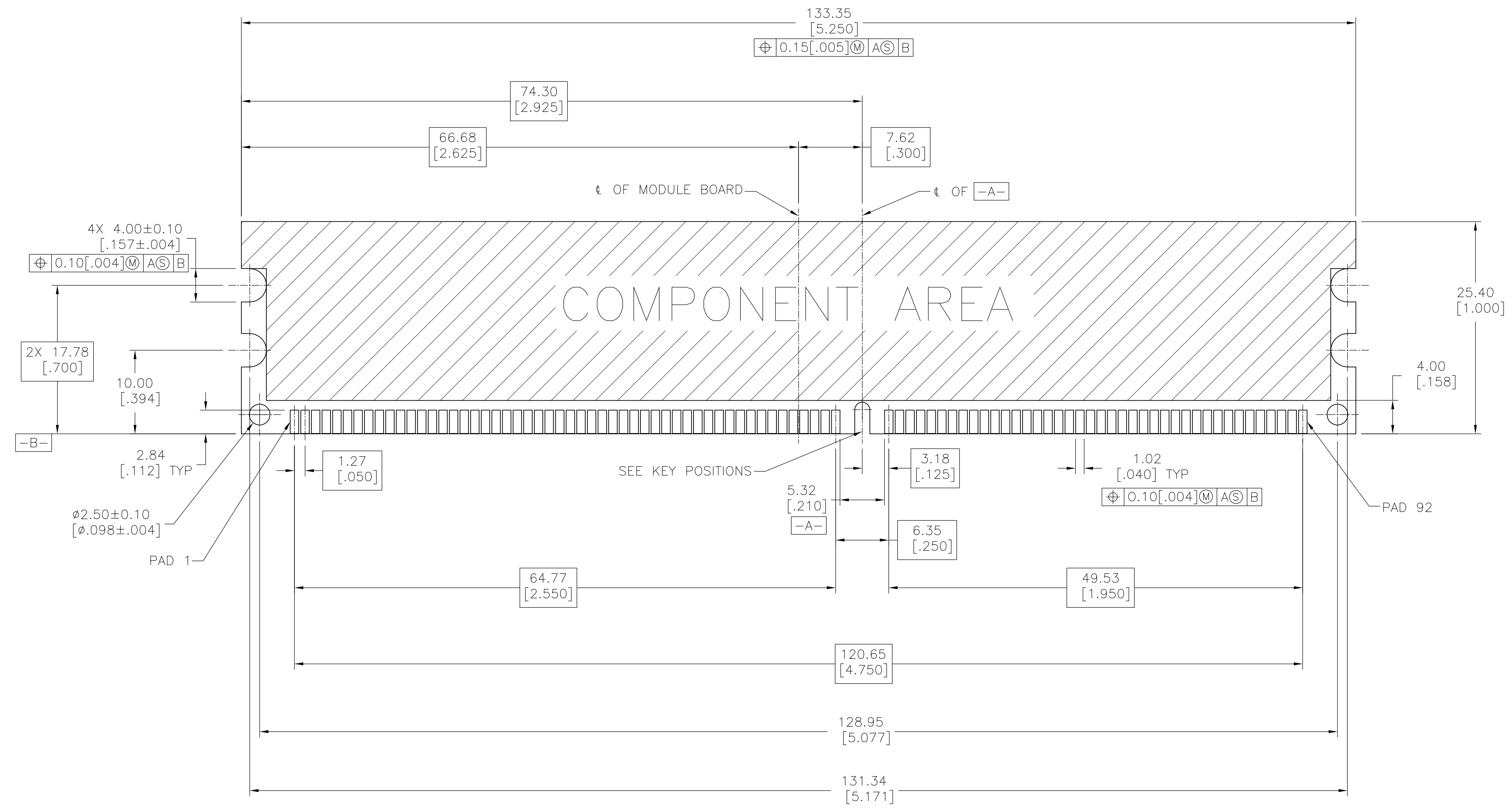

RECOMMENDED MODULE LAYOUT

THIS DRAWING IS A CONTROLLED DOCUMENT.		DN: S. WAITMAN 11OCT04	Tyco Electronics Corporation Harrisburg, Pa 17105-3608
DIMENSIONS: mm		CHK: M. YFOMANS 11OCT04	
TOLERANCES UNLESS OTHERWISE SPECIFIED:		APP'D: M. YFOMANS 11OCT04	NAME: SOCKEY ASSEMBLY, 184 POS, DDR LOW PROFILE DIMM2P, LEAD FREE
0. PLC ± -	1. PLC ± -	PRODUCT SPEC	APPLICATION SPEC
2. PLC ± 0.13 [.005]	3. PLC ± -	SIZE: A1	WEIGHT: -
4. PLC ± -	ANGLES ± -	CAGE CODE: 00779	DRAWING NO: 5390402
MATERIAL: 1	FINISH: 2	CUSTOMER DRAWING	SCALE: 3:1
		SHEET: 2 OF 3	REV: A1

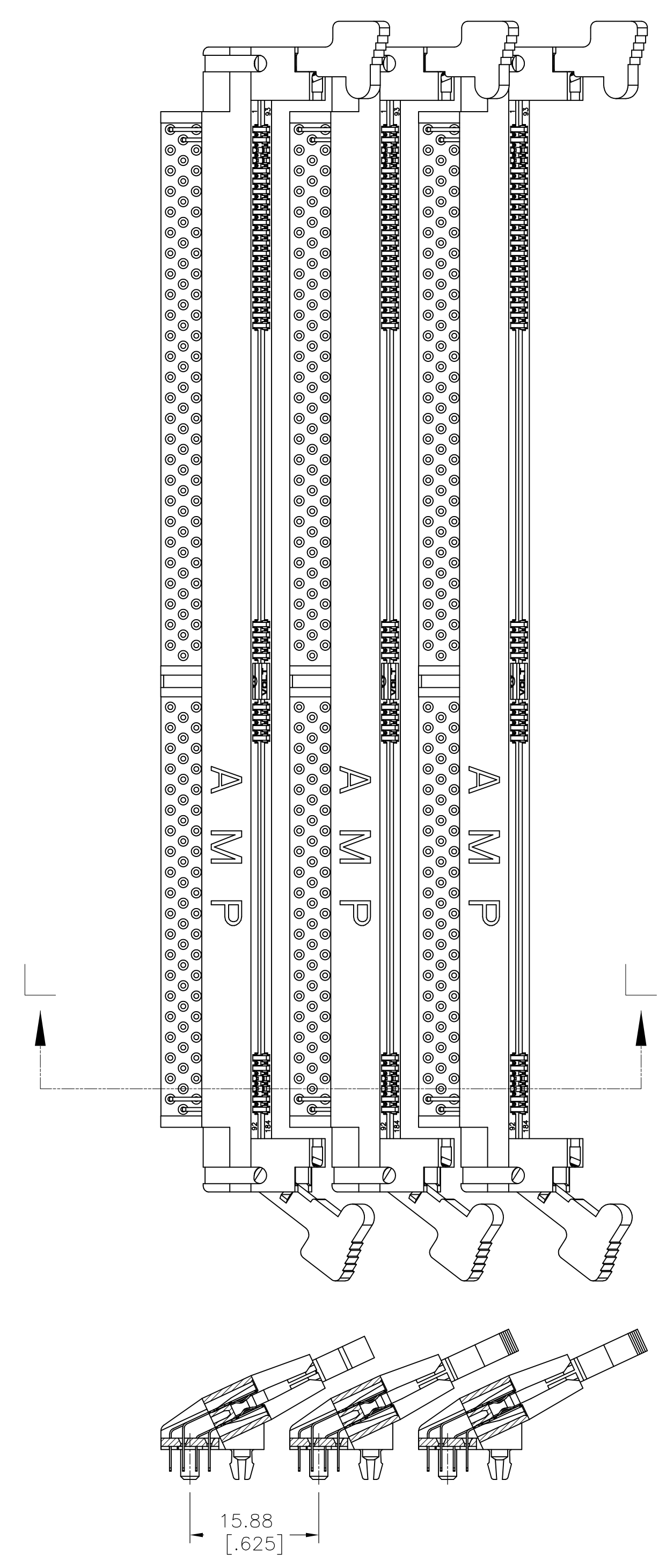

SECTION L-L
SCALE 2:1

MINIMUM REPAIRABLE
SOCKET TO SOCKET REPAIRING

WITH THE MODULES REMOVED SOCKETS ON 15.88[.625] OR GREATER SPACING CAN BE INDIVIDUALLY UNSOLDERED FROM THE BOARD AND REMOVED IF NECESSARY

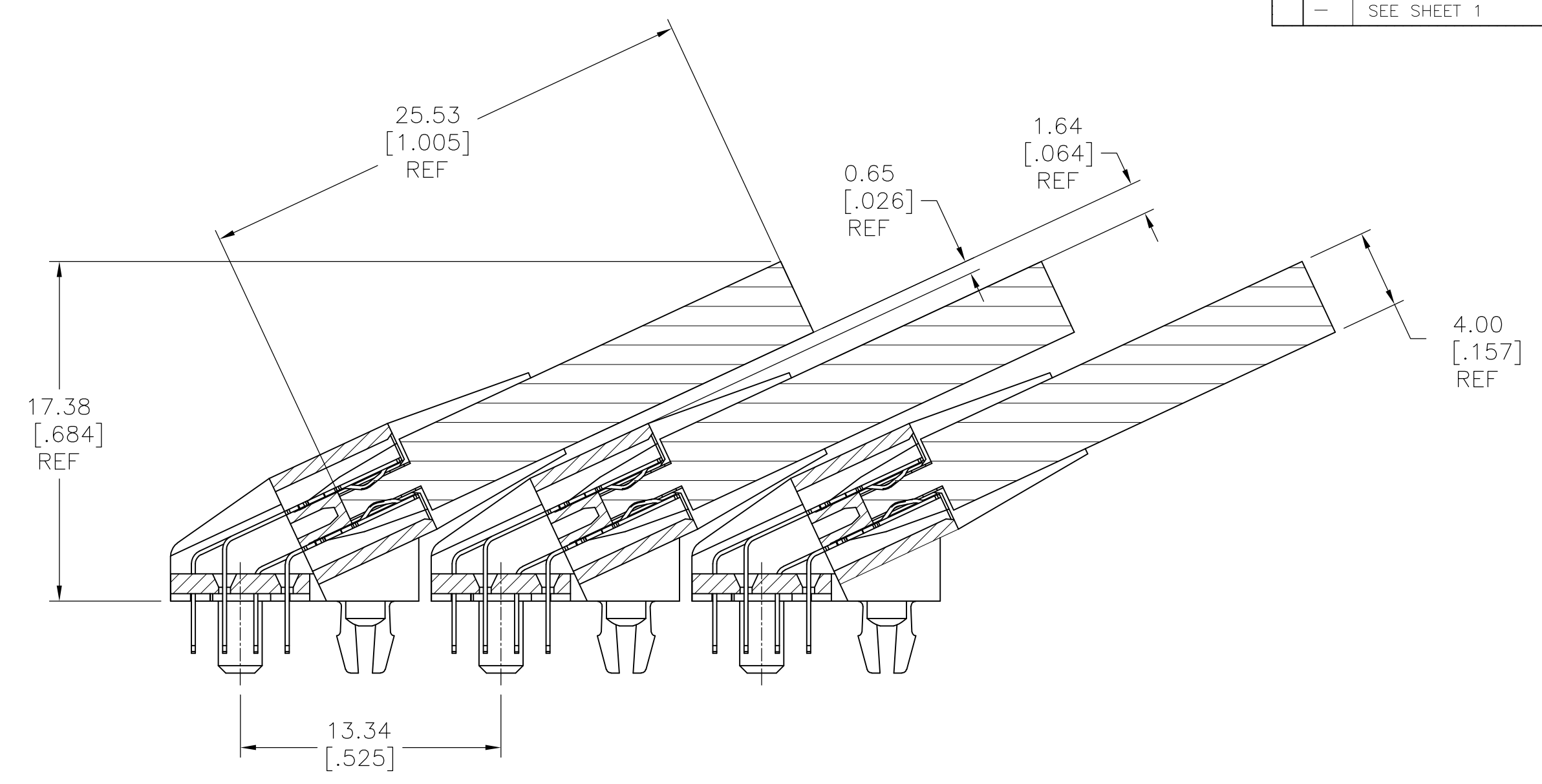

MINIMUM SOCKET TO SOCKET SPACING

WITH A 4.00[.158] WIDE MODULE BOARD, A SOCKET TO SOCKET SPACING OF 13.34[.525] WILL LEAVE APPROXIMATELY 0.65[.026] OF CLEARANCE BETWEEN THE MODULE AND THE NEXT SOCKET BODY. THIS SPACING MAY OR MAY NOT BE SUITABLE DEPENDING ON YOUR MINIMUM GAP REQUIREMENTS.

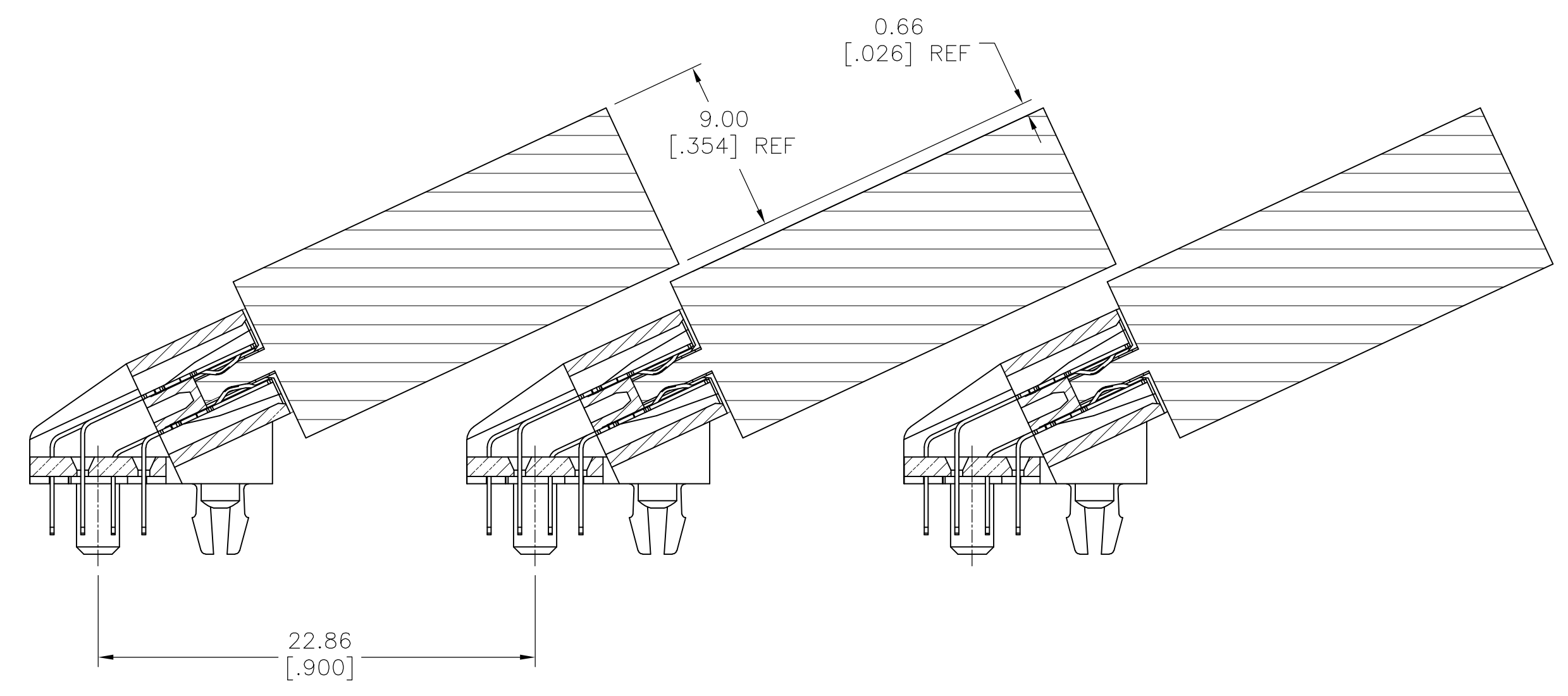

POSSIBLE SOCKET TO SOCKET SPACING FOR 9MM MODULE

WITH A 9.00[.355] WIDE MODULE BOARD; A SOCKET TO SOCKET SPACING OF 22.86[.900] WILL LEAVE APPROXIMATELY 0.66[.026] CLEARANCE BETWEEN THE ADJACENT MODULES. THIS SPACING MAY OR MAY NOT BE SUITABLE DEPENDING ON YOUR MINIMUM GAP REQUIREMENTS.

THIS DRAWING IS A CONTROLLED DOCUMENT.		DN S. WAITMAN 11OCT04	Tyco Electronics Corporation Harrisburg, Pa 17105-3608	
DIMENSIONS:		CHK M. YFOMANS 11OCT04	NAME	
TOLERANCES UNLESS OTHERWISE SPECIFIED:		APVD M. YFOMANS 11OCT04	PRODUCT SPEC	
mm		APPLICATION SPEC	SIZE	
0 PLC ± -		WEIGHT	CAGE CODE	
1 PLC ± -		SCALE	DRAWING NO	
2 PLC ± 0.13[.005]		RESTRICTED TO	A1 00779 C=5390402	
3 PLC ± -		CUSTOMER DRAWING	SCALE 4:1 SHEET 3 OF 3 REV A1	
4 PLC ± -				
ANGLES ± -				
FINISH				